

MOTION DETECTOR INTERFACE

ADVANCE DATA

- 50/ 60 Hz AC SUPPLY
- INPUT FOR PYROELECTRICAL SENSOR
- INPUT FOR PHOTORESISTIVE SENSOR
- SENSOR FILTER AMPLIFIER
- PROGRAMMABLE ON-TIMER
- TRIAC OUTPUT AND RELAY OUTPUT
- SHORT CIRCUIT PROTECTION
- LOW QUIESCENT CURRENT
- TWO-WIRE TECHNIQUE

DESCRIPTION

The UAA4713 is a monolithic integrated circuit intended to control triac or relay switch for AC-mains timer applications. The device can be used in a wide range of industrial and consumer applications as light control, automatic door opening detector, fire alarm, fluid level control .

The circuit processes the output signal of an infra-red pyroelectric detector which senses temperature changes caused by heat radiation of the human body.

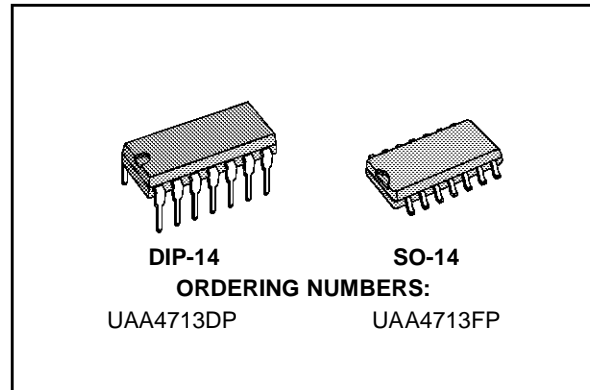

If the sensor detects a temperature change, a programmable timer will start and switch a lamp or other loads to the mains.

A further input for a photo-resistive sensor allows to program circuit operation depending on the day-light intensity.

Internal circuits avoid false triggering of the external actuators. (see functional diagram).

BLOCK DIAGRAM

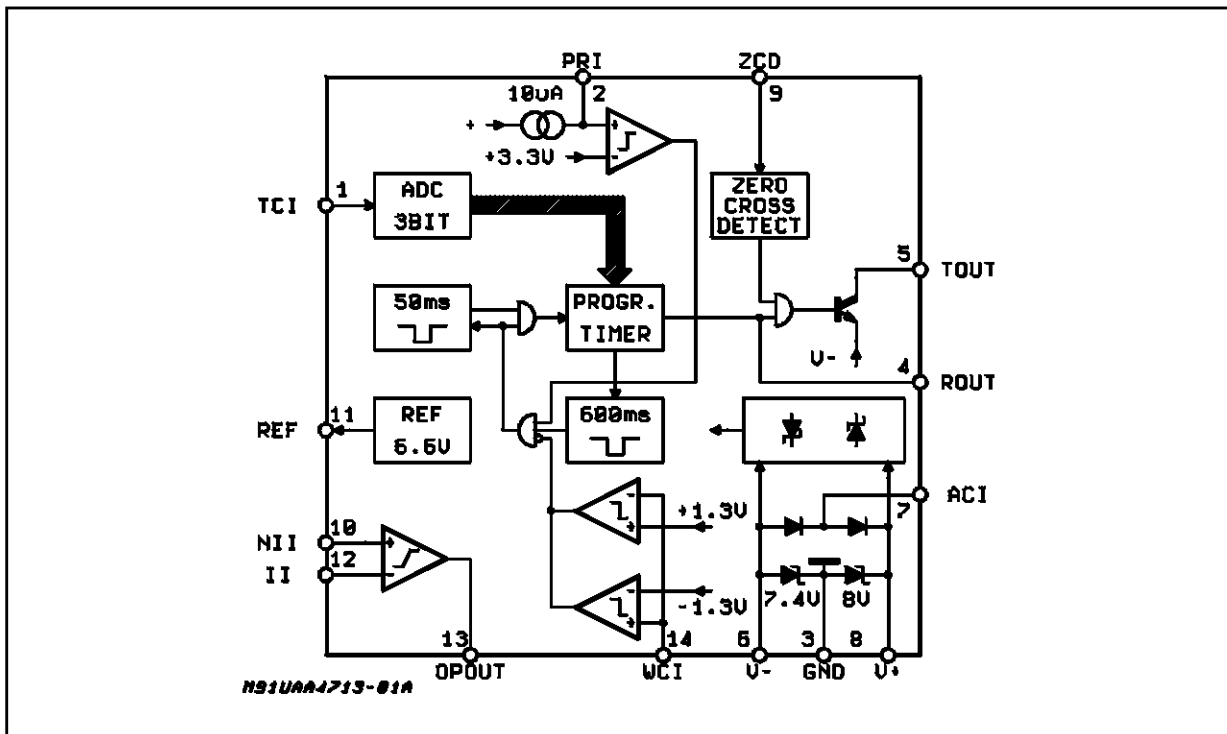

FUNCTIONAL DIAGRAM

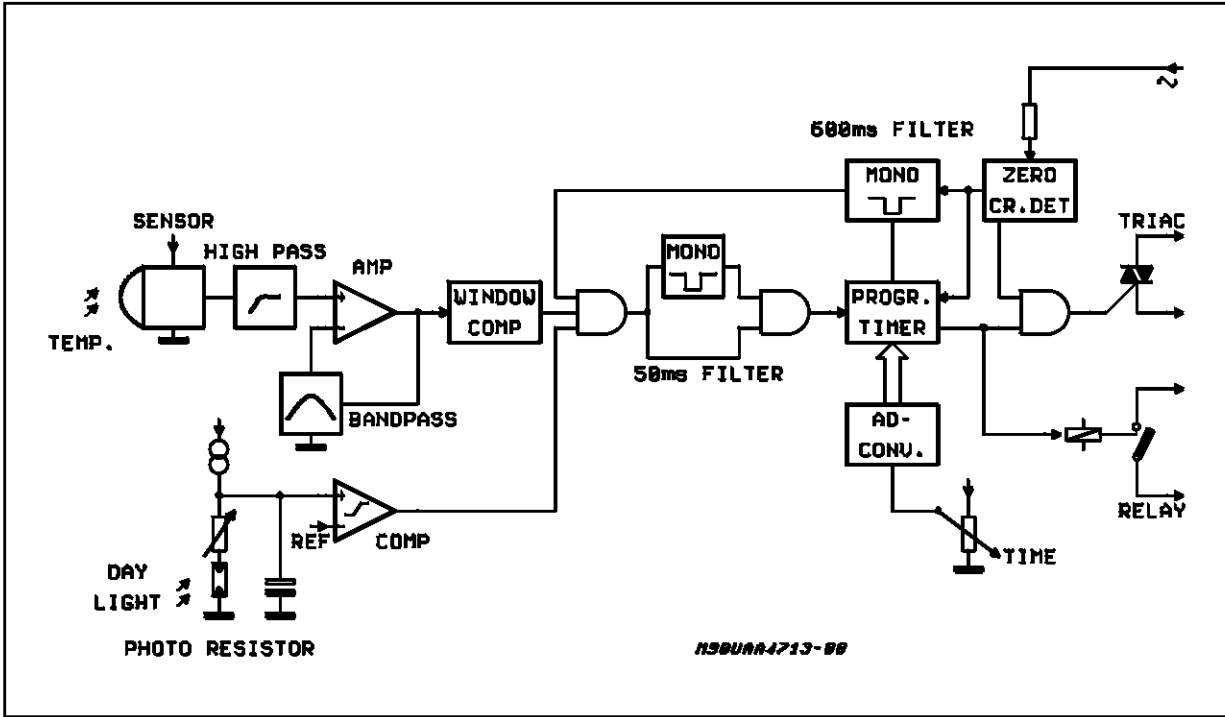

ABSOLUTE MAXIMUM RATINGS

Symbol	Parameter	Test Conditions	Unit
I7	AC Supply Current	60	mA
I7	Peak Current (T.P < 200µs)	200	mA
I7	Source Current (not repetitive 10ms)	500	mA
I9	ZCD Max. Input Current	5	mA
V6-3	Negative Clamp Voltage	-9	V
V8-3	Positive Clamp Voltage	9.5	V
V14-3	Comp. Input Voltage	±8	V
V10-12	Differential Input Voltage	±8	V
Top	Operating Temperature	-25 to 85	°C
T _{stg} , T _j	Junction and Storage Temperature	-40 to 150	°C
P _{tot}	Total Power Dissipation (T _j = 85°C)	650	mW

THERMAL DATA

Symbol	Parameter	Value	Unit
R _{th j-amb}	Thermal Resistance Junction-ambient	max 100	°C/W

PIN CONNECTION (Top view)

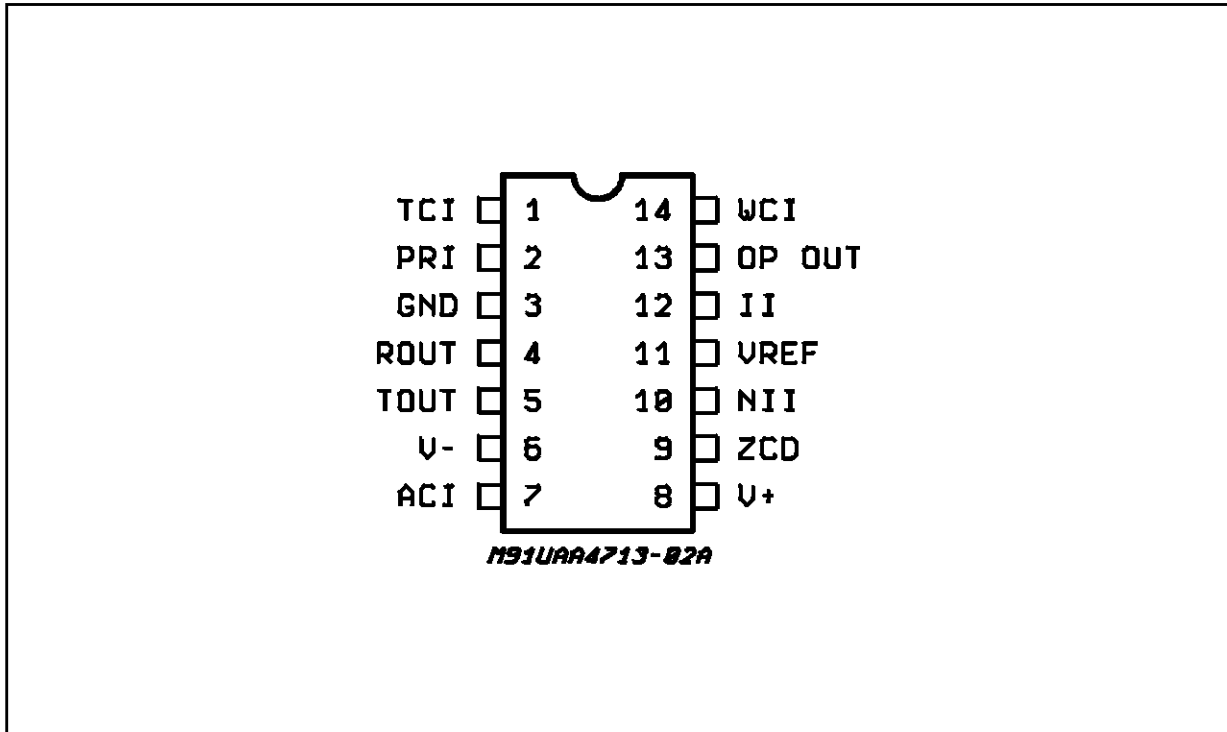

PIN FUNCTIONS

Pin	Symbols	Functions
1	TCI	Time control Input
2	PRI	Photosensor comparator input
3	GND	Ground
4	R _{OUT}	Relay output
5	T _{OUT}	Triac output
6	V-	Negative clamp voltage
7	ACI	AC-input supply
8	V+	Positive clamp voltage
9	ZCD	Zero cross detector
10	NII	Non-invert input sensor amplifier
11	V _{REF}	Sensor reference voltage
12	II	Invert input sensor amplifier
13	OP OUT	Output sensor amplifier
14	WCI	Window comparator input

ELECTRICAL CHARACTERISTICS ($I_S = \pm 2\text{mA}$ to $\pm 10\text{mA}$; $T_{\text{amb}} = 25^\circ\text{C}$ unless otherwise specified)

Symbol	Parameter	Test Condition	Pin	Min.	Typ.	Max.	Unit
I_S	Operative Supply Current		7	± 0.7		± 15	mA
V-	Negative Clamping Voltage	$\pm I_S = 0.7\text{mA}$	6	-7.8		-7	V
V+	Positive Clamping Voltage		8	7.6		8.4	V
V_{REF}	Sensor Reference Voltage	$I_{\text{REF}} = 50\mu\text{A}$ $I_{\text{REF}} = 200\mu\text{A}$	11	6 5	6.6	7.2 7.2	V V
I_{ROUT}	Output Current Relay Driver	during on-time $V_{\text{ROUT}} = 0\text{V}$	4	80			μA
$V_{\text{R HIGH}}$	Relay Driver Source Saturation Voltage	$I_{\text{ROUT}} = 80\mu\text{A}$	4			2	V
I_{R}	Relay Sink Output Current	$V_{\text{ROUT}} = 0.4\text{V}$ during on-time	4	1		8	mA
I_{TOUT}	Triac Firing Current		5	50	65		mA
V_{ZCD}	Zero Cross Detector Clamping Voltage		9	± 7.4	± 8	± 8.6	V
I_{ZCD}	Zero Cross Detector Operating Current		9	1.6		10	μA
I_{PRI}	Photoresistor Source Current	$V_{\text{PRI}} = 0\text{V}$	2	6	10	14	μA
V_{PRth}	Photoresistor Threshold Voltage	$I_S = 0.7\text{mA}$	2	3	3.3	3.6	V
I_{TCI}	Timer Control Input Current	$V_{\text{TCI}} 0$ to V_+	1	0		0.5	μA
t_{TIM}	On-Timer Counter Duration (depends on the mains frequency and on externally adjustable Timer Control Input Voltage) $\pm 1/2$ cycle precision	V_{TCI}	14/4	50		60	Hz
		11/12 V_+		0		0	s
		9/12 V_+		4.48		3.73	s
		7/12 V_+		40		33.3	s
		5/12 V_+		81		67.5	s
		3/12 V_+		163		135.8	s
		1/12 V_+		327		272.5	s
		0V (GND)	Continue				
t_{D}	Delay Time Between Window Comparator Input and Timer Start	50Hz	14/4	40	50	60	ms
		60Hz		33.3	41.6	50	ms
t_{DR}	Delay Time Between Timer Stop to Retrigger	50Hz	14/4		500		ms
		60Hz			600		ms
I_{TOL}	Triac Output Leakage Current	$V_{\text{TO}} = 0\text{V}$	5			10	μA
$V_{\text{th WCI}}$	Window Comparator T4	Pin 2 open	14/4	± 1.20	± 1.3	± 1.40	V
I_{WCI}	Window Comparator Input Current	$V_{\text{WCI}} = -2\text{V}$ to $+2\text{V}$	14			± 1	mA
OP. AMP.							
R_i	Input Resistance		10/12		1		$\text{M}\Omega$
I_{IO}	Input Offset Current		10/12			25	nA
I_{IB}	Input Bias Current		10/12			1	μA
V_{IO}	Input Offset Voltage		10/12	- 10		+10	mV
V_{CM}	Common Mode Volt. Renge		10/12	- 4.5		5	V
V_{O}	Output Voltage Swing		13	± 4		± 5	V
I_{O}	Output Current		13		1.5		mA
I_{SC}	Output Short Circuit Current		13			3	mA
G_v	Large Signal Open Loop Voltage Gain	$R_L = 10\text{K}$		80	100		V

Figure 1: Open Loop Frequency Response

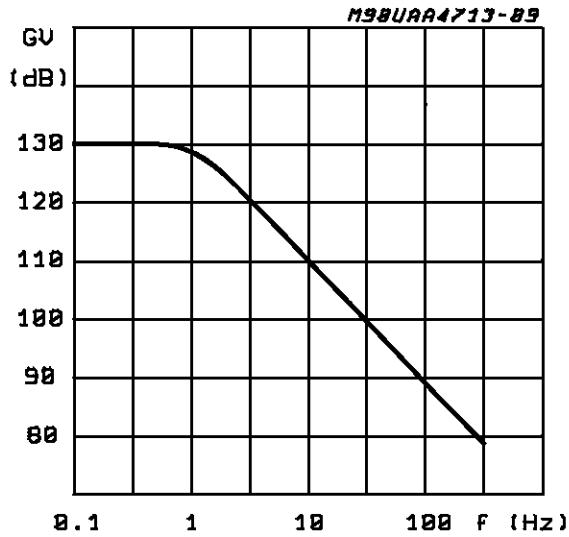

Figure 2: V_{REF} versus I_{REF}

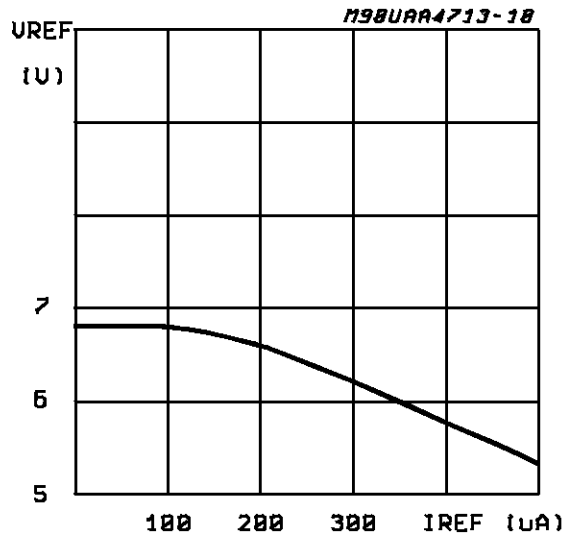
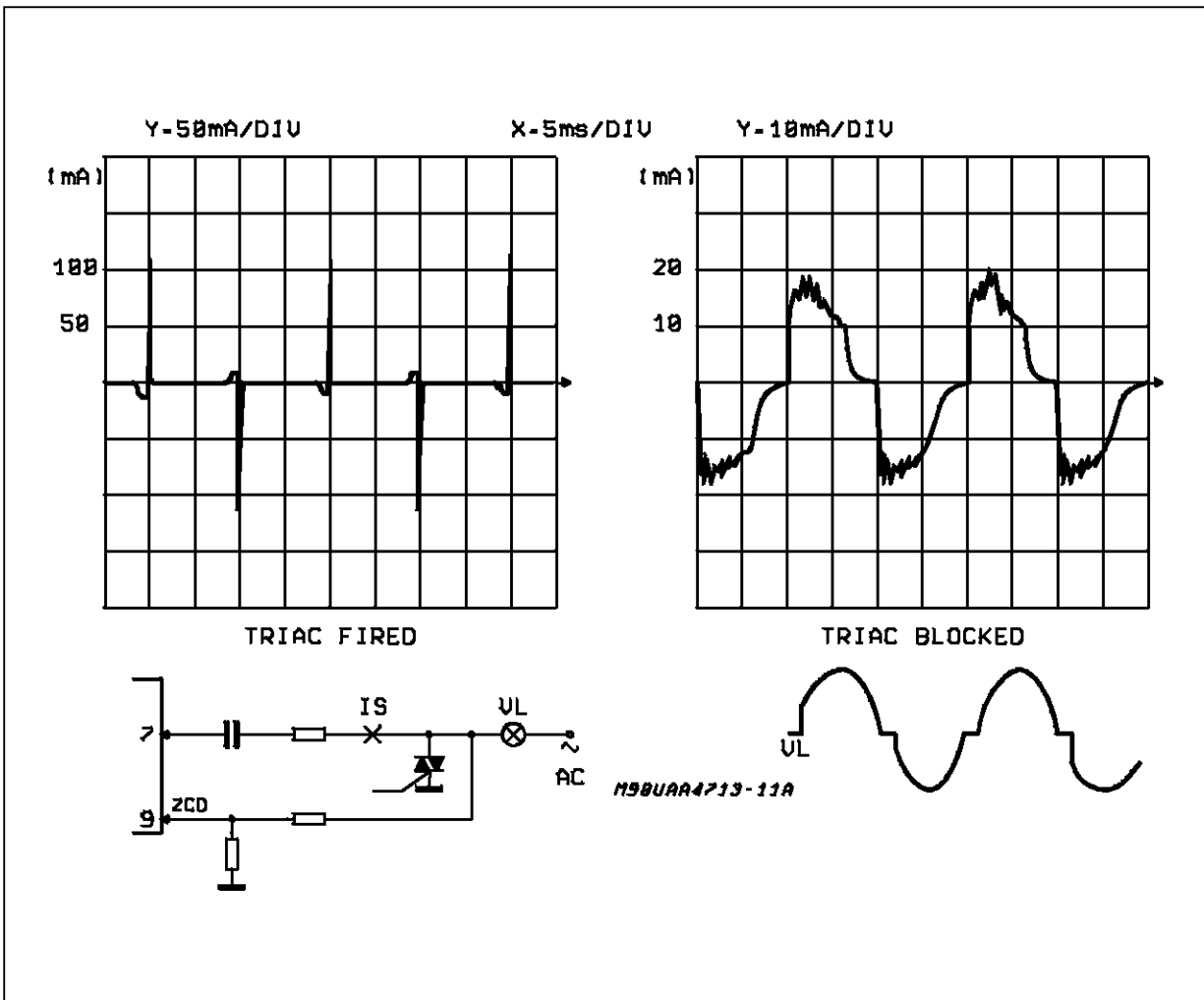

Figure 3: Supply Current



UAA4713

SYSTEM DESCRIPTION (see Functional Diagram)

If a heat source moves in front of the IR-detector, the sensor delivers a quasi sinusoidal AC-signal in the μV to mV range. The operational amplifier amplifies the sensor signal by 72dB.

To reject an unwanted signal, a band pass filter is needed. If the AC-level at pin 14 exceeds the window comparator thresholds, the programmable timer will start. To suppress short sensor signals, a 50ms time filter is implemented between the window comparator output and the programmable timer. This function improves the noise immunity.

After the reset of the timer a second timer will provide a 600ms dead time to prevent retriggering of the timer. This function avoids restarting of the timer, when the turned off lamp temperature decreases.

The lamp switched by the triac can be located close to the sensor.

To avoid circuit operation during day-time, a photo resistor (LDR) senses the light intensity and switches off the circuit. The capacitor at pin 2 prevents circuit start-up during short shadow phases, when a person passes by the sensor.

From the analog input pin 1 via the AD-converter the on-time duration can be programmed in 7

steps (see t_{TIM} table in the electrical characteristics). The timer is clocked by the mains frequency.

Two outputs for various applications are available.

Pin 5 is the trigger output for triac gate.

Pin 4 output can be used to switch a relay or other loads.

The zero crossing detector provides the firing pulse for the triac at the right time, shortly after the zero crossing of the AC-signal.

The RC-network at pin 7 supplies current to the circuit via a double wave rectification which is provided by a split power supply. Due to the capacitive energy transfer into pin 7, the circuit will also be supplied with current if the triac is fired. A short wire for circuit supply is not needed.

The circuit works similar to a simple two-terminal switch and can be installed in parallel with ordinary mechanical pulse switches (fig. 4).

After a short supply connection via an external pulse switch, the circuit timer will also start without a sensor signal.

Therefore the circuit can also be used as an ordinary light timer without the IR-moving sensor feature.

Figure 4

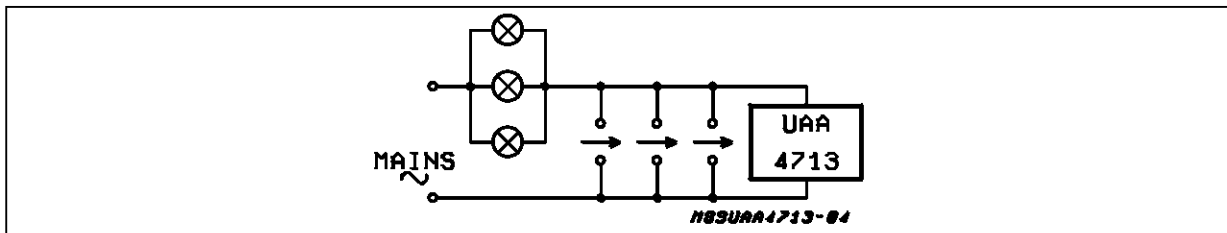
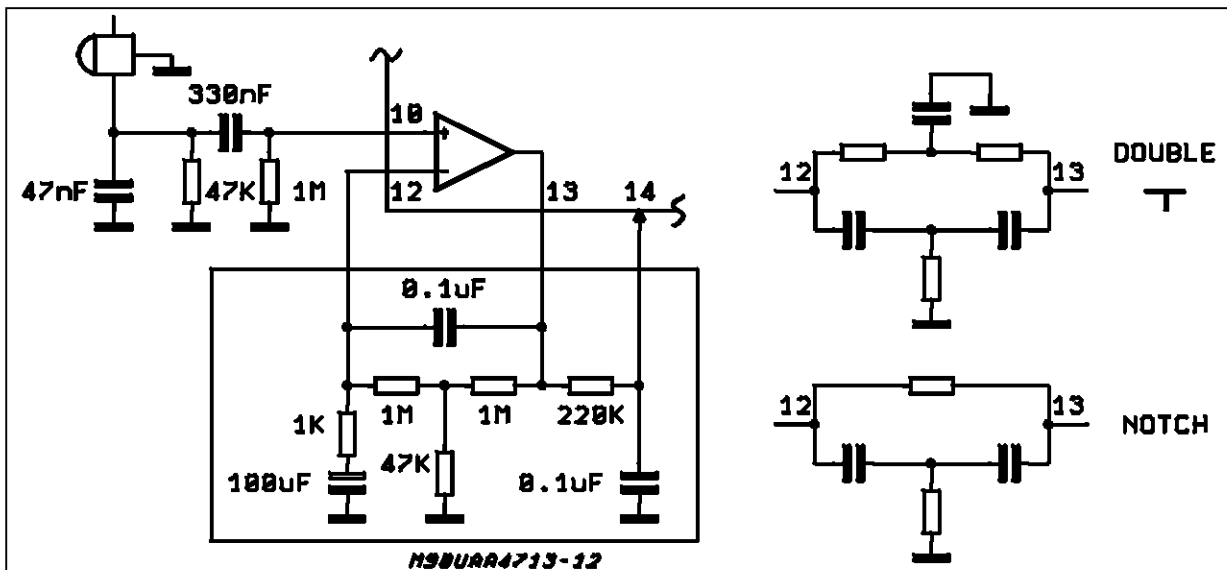

Figure 5: Different Possible Filter Solutions



APPLICATION INFORMATION

1. HOW TO CHOOSE THE TRIAC ASSOCIATED TO THE MOTION DETECTOR UAA4713

Analysis of the Triac Associated to the Motion Detector UAA4713

Associated with the UAA4713, the Triac is defined by the driver output stage (Triac output pin 5) and the characteristics of the load.

The Triac is consequently defined by:

- 1) The gate sensitivity
- 2) The surge current capability
- 3) The RMS Triac current
- 4) The blocking voltage capability

1) The gate sensitivity

The "Triggering gate current" is the parameter to be taken into consideration. The I_{GT} is given at 25°C. as a maximum value required to trigger the Triac.

ex. BTA06-600CW = $I_{GT \max}$ (mA) = 35mA

The UAA4713 Triac output provides a current of 65mA typical.

$$I_{Tout} = 65mA(Typ) = I_G$$

In order to control the Triac properly I_G should be greater than $1.5 \times I_{GT}$ or

$$I_{Tout} > 1.5 I_{GT}$$

For this reason it is suggested to use a snubberless Triac of the CW series ($I_{GT} < 35mA$).

2) The surge current capability

In the Triac databook the surge current capability of the Triac is given by the non repetitive surge peak current:

I_{TSM}

ex. BTA06-600CW

I_{TSM} at $T_J \text{ initial} = 25^\circ C$

t = 8.3ms: 63A

t = 10ms: 60A

The choice of the Triac is defined by the following application parameters:

- a) The starting performance, and the ratio of the nominal resistance to the cold resistance, KR

$$I_{max} > KR \times I_{nominal} \times \sqrt{2}$$

- b) The thermal fast fuse behaviour during short-circuit condition.

$$(I^2t) \text{ (Triac)} > (I^2t) \text{ (fuse)}$$

To select the I_{Tsm} (given as a minimum value) the following table is suggested.

Mains: V_{AC} (V)	240V	110V
Power (W)	$I_{Tsm}(\text{min})$	$I_{Tsm}(\text{min})$
600	50	80
1000	80	120
>1000	>100	>150

3) RMS Triac Current

The RMS Triac current I_{TRMS} is defined by the light power P:

$$I_{TRMS} > 1.25 \times P \times V_{AC}$$

It depends also on the heat sink which has to limit the junction temperature in the worse case conditions ($T_{amb \max}$ and I_{TRMS}).

With the snubberless triac I_{TRMS} ranges from 6A to 25A.

4) Blocking Voltage Capability

The maximum blocking voltage V_{DRM} is defined by the mains:

Country	Mains Voltage (V) V_{AC}	V_{DRM} (V)
EUROPE	240	600
USA	110	400

5) Conclusion:

Selector guide with the above parameters the optimal device selection for a given power to be controlled is given in the following table:

LIGHT POWER (W)	MAINS VOLTAGE V_{AC} (V)	
	240	110
600	BTA 06 600 CW	BTA 08 400 CW
1,000	BTA 08 600 CW	BTA 12 400 CW
> 1,000	BTA X 600 CW X = 10 X = 12 X = 16	BTA X 400 CW X = 12 X = 16 (A)

Ref: High Performance Triacs that need no snubber (DSTRIACBK/1088)

Figure 8: Demo Board Diagram

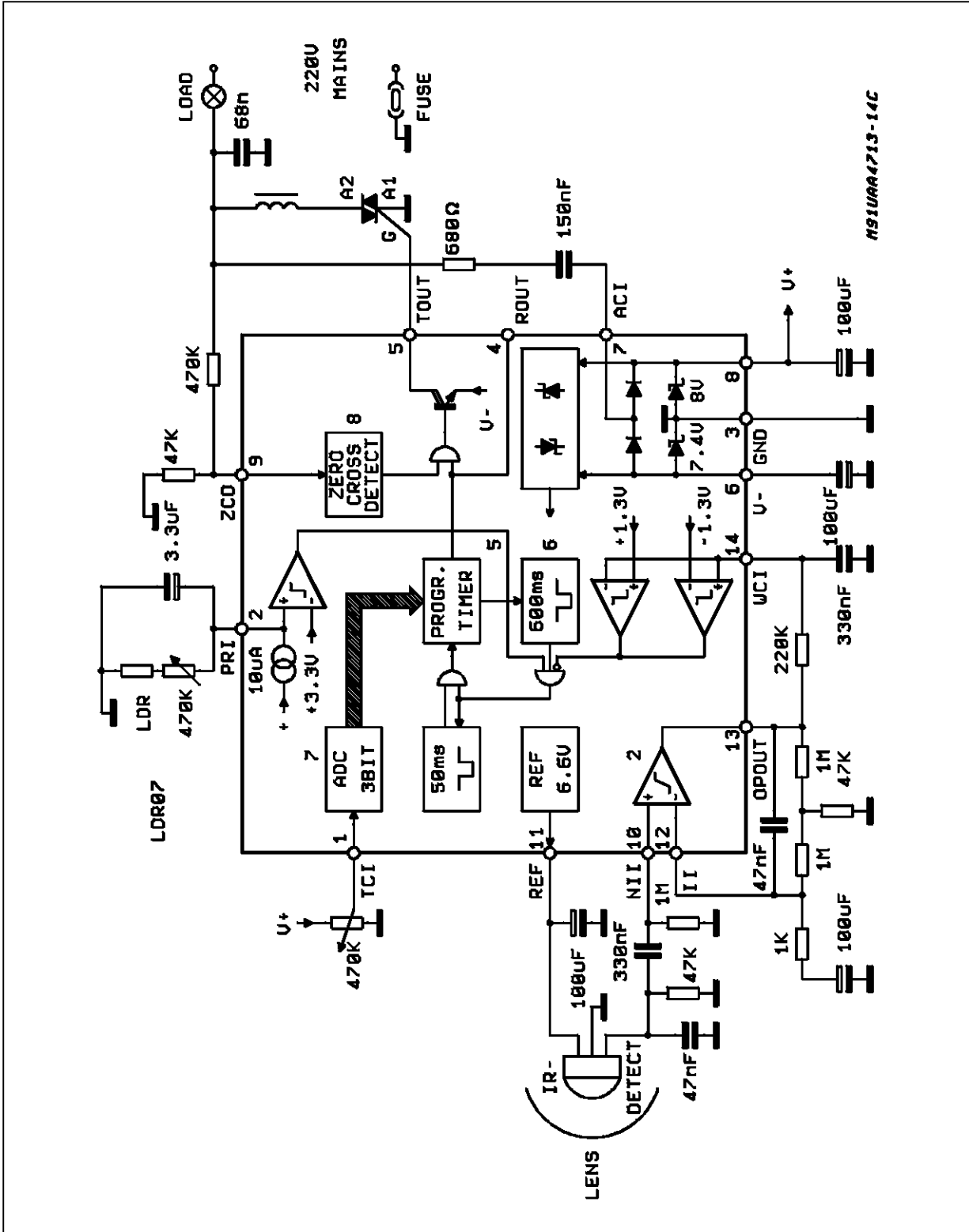

APPLICATION INFORMATION (continued)

Demo Board - Part List

QTY	DEVICE	DESCRIPTION	SUPPLIER
1	UAA4713DP OR UAA4713FP	INTEGRATED CIRCUIT	SGS-THOMSON
1	BTA06-600 (240V mains) BTA08-400 (110V mains)	TRIAC TRIAC	SGS-THOMSON SGS-THOMSON
1	KRX10FL or IRA - E100S series	SENSOR WITH FRESNEL LENS Pyroelectric Infrared Sensor	PHILIPS COMPONENTS MURATA
1	LDR07	PHOTORESISTOR	PHILIPS COMPONENTS
CAPACITORS		RESISTORS (0.25W)	
QUANTITY	VALUE	QUANTITY	VALUE
4	100 μ F/35V	3	1M Ω
2	330nF	3	47k Ω
2	47nF	1	680 Ω
1	4.7nF	1	1K Ω
1	68nF 400V	1	470K Ω
1	150nF 250V	1	220K Ω
1	3.3 μ F 35V	2 POTENTIOMETERS	
			500K Ω

Figure 9: Demo Board Photo IRA - E100S

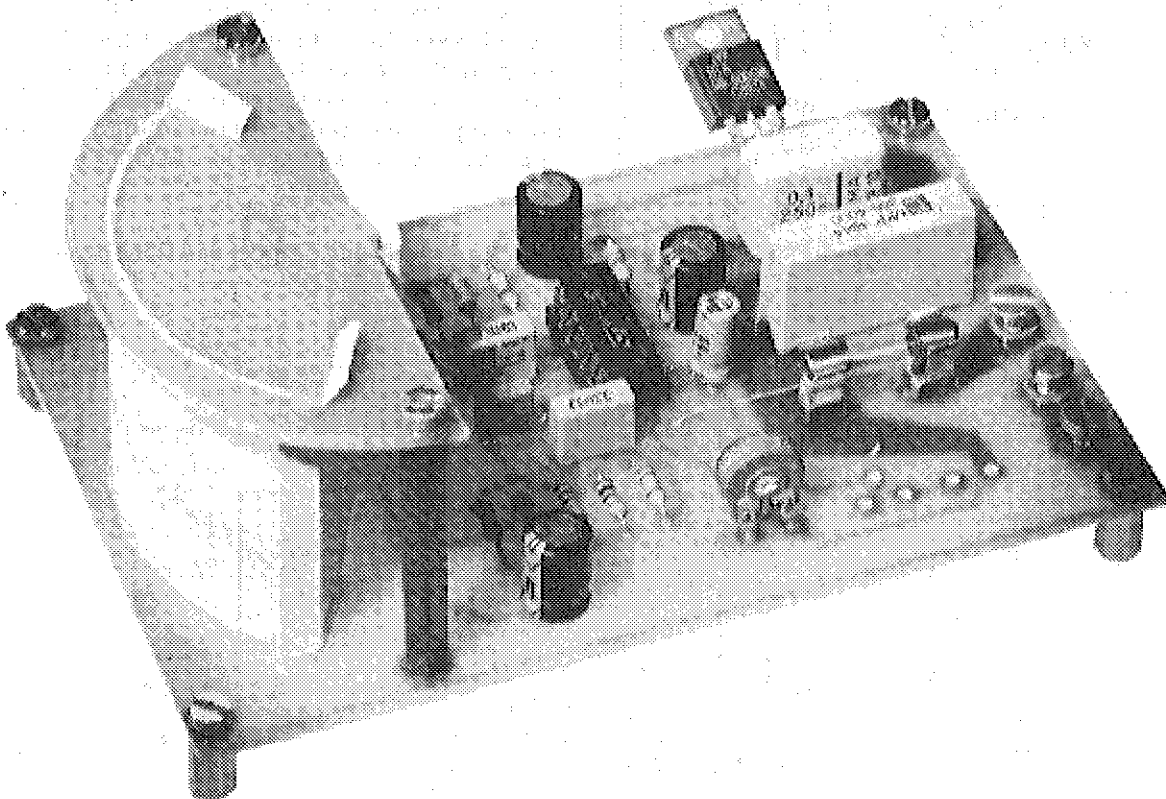

DIP14 PACKAGE MECHANICAL DATA

DIM.	mm			inch		
	MIN.	TYP.	MAX.	MIN.	TYP.	MAX.
a1	0.51			0.020		
B	1.39		1.65	0.055		0.065
b		0.5			0.020	
b1		0.25			0.010	
D			20			0.787
E		8.5			0.335	
e		2.54			0.100	
e3		15.24			0.600	
F			7.1			0.280
I			5.1			0.201
L		3.3			0.130	
Z	1.27		2.54	0.050		0.100

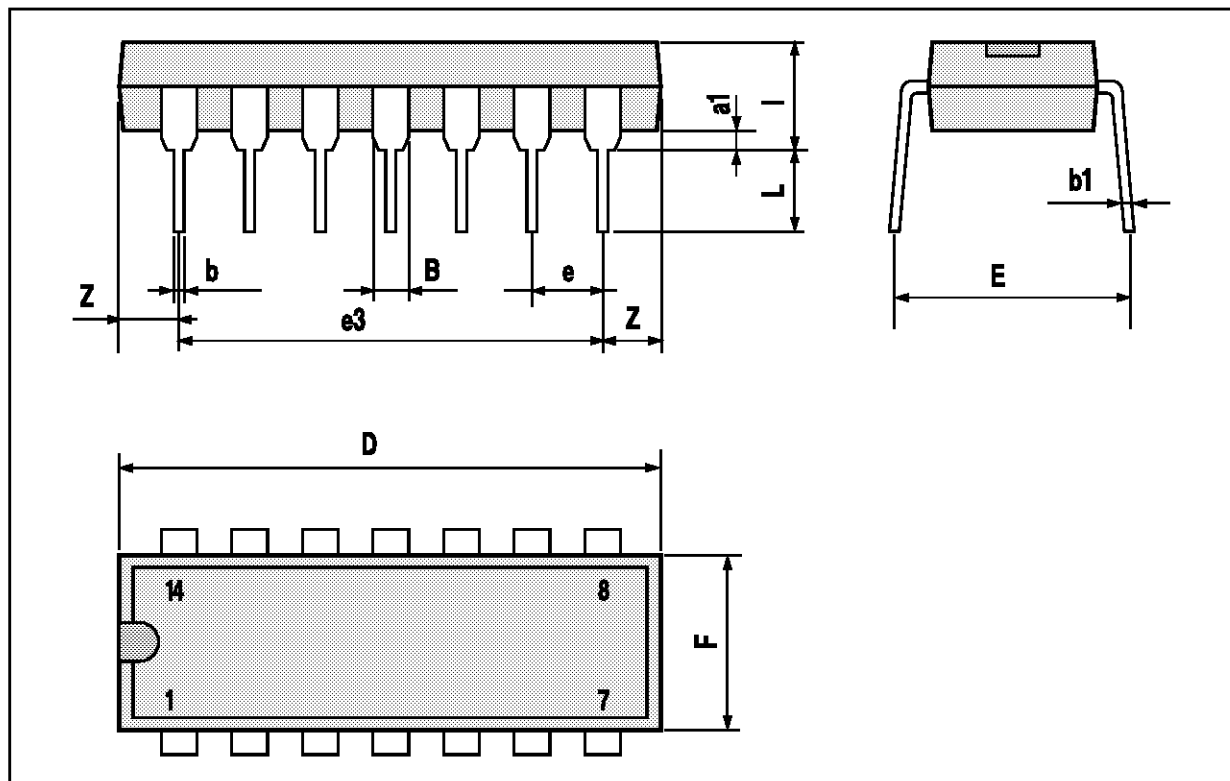

SO14 PACKAGE MECHANICAL DATA

DIM.	mm			inch		
	MIN.	TYP.	MAX.	MIN.	TYP.	MAX.
A			1.75			0.069
a1	0.1		0.25	0.004		0.009
a2			1.6			0.063
b	0.35		0.46	0.014		0.018
b1	0.19		0.25	0.007		0.010
C		0.5			0.020	
c1	45 (typ.)					
D	8.55		8.75	0.336		0.344
E	5.8		6.2	0.228		0.244
e		1.27			0.050	
e3		7.62			0.300	
F	3.8		4.0	0.15		0.157
L	0.4		1.27	0.016		0.050
M			0.68			0.027
S	8 (max.)					

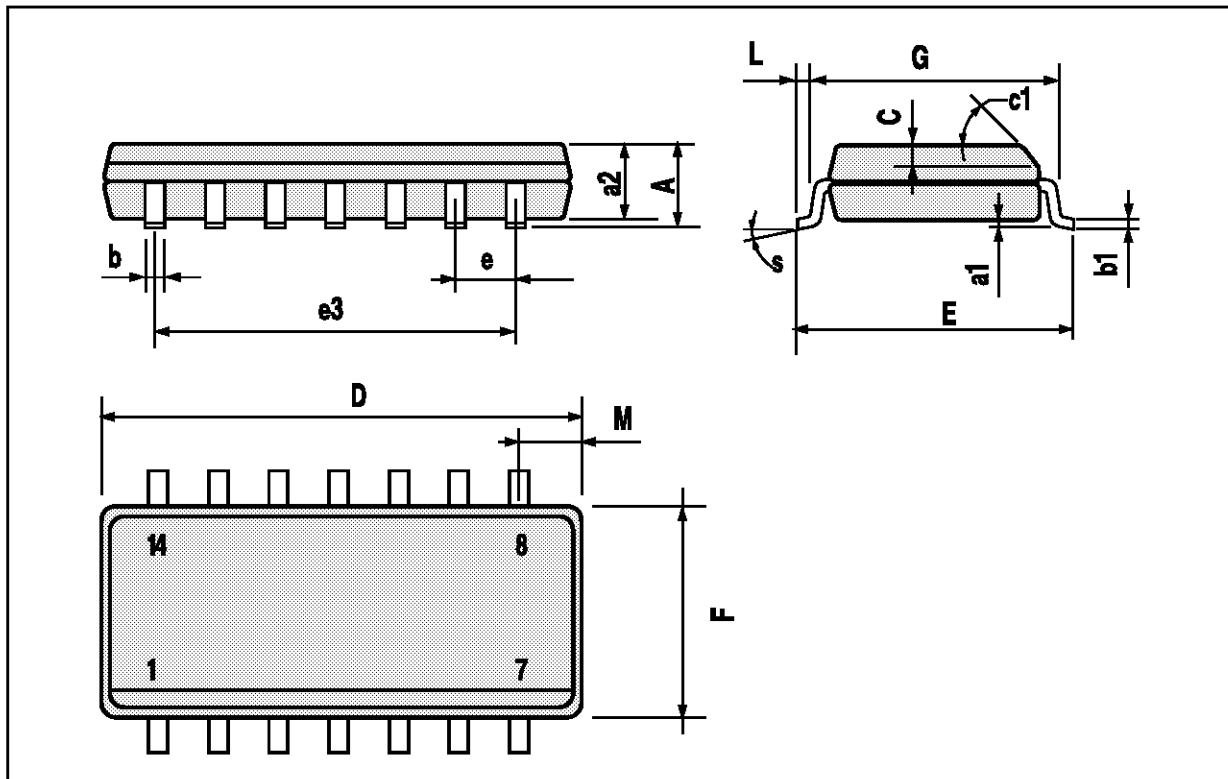

Information furnished is believed to be accurate and reliable. However, SGS-THOMSON Microelectronics assumes no responsibility for the consequences of use of such information nor for any infringement of patents or other rights of third parties which may result from its use. No license is granted by implication or otherwise under any patent or patent rights of SGS-THOMSON Microelectronics. Specifications mentioned in this publication are subject to change without notice. This publication supersedes and replaces all information previously supplied. SGS-THOMSON Microelectronics products are not authorized for use as critical components in life support devices or systems without express written approval of SGS-THOMSON Microelectronics.

© 1994 SGS-THOMSON Microelectronics - All Rights Reserved

SGS-THOMSON Microelectronics GROUP OF COMPANIES

Australia - Brazil - France - Germany - Hong Kong - Italy - Japan - Korea - Malaysia - Malta - Morocco - The Netherlands - Singapore - Spain - Sweden - Switzerland - Taiwan - Thailand - United Kingdom - U.S.A.