

### MONOLITHIC CD-ROM 3-PHASE SPINDLE MOTOR DRIVER

The  $\mu$ PD16856 is a CD-ROM 3-phase spindle motor driver consisting of a CMOS controller and MOS bridge outputs.

By employing 3-phase full-wave PWM as the drive method and MOS FETs at the output stage, it has been possible to reduce the power consumption of the  $\mu$ PD16856 ever further than the conventional linear drive drivers that use bipolar transistors.

By using a 30-pin shrink SOP package, a more compact-size has been achieved.

#### FEATURES

- Supply voltage for controller block: 5 V, supply voltage for output block: 12 V  
3 V input available for the input interface
- Low on-state resistance (total on-state resistance of upper and lower MOS FETs)  $R_{ON} = 1.3 \Omega$  (TYP.)
- Low power consumption due to 3-phase full-wave PWM drive method
- On-chip hole bias switch (linked with STB pin)
- On-chip IND (FG) pulse switching function, 1-phase output or 3-phase composite output
- START/STOP pin included, acting as a brake during STOP
- Standby pins included, turning off internal circuit in standby
- Low current consumption:  $I_{DD} = 3 \text{ mA}$  (Max.),  $I_{DD} (ST) = 1 \mu\text{A}$  (Max.)
- On-chip thermal shutdown circuit
- On-chip current limiting circuit; reference voltage can be set externally
- On-chip low voltage malfunction prevention circuit
- On-chip reverse rotation prevention circuit
- 30-pin plastic shrink SOP (300 mil)

#### ORDERING INFORMATION

Part Number	Package
$\mu$ PD16856GS	30-pin shrink SOP (0.8-mm pitch, 300 mil)

The information in this document is subject to change without notice.

**ABSOLUTE MAXIMUM RATINGS (T<sub>A</sub> = 25°C)**

Parameter	Symbol	Conditions	Ratings	Unit
Supply voltage	V <sub>DD</sub>		-0.5 to +6.0	V
	V <sub>M</sub>		-0.5 to +13.5	V
Input voltage	V <sub>IN</sub>		-0.5 to V <sub>DD</sub> + 0.5	V
Instantaneous output current <sup>Note 1</sup>	I <sub>DR (pulse)</sub>	PW ≤ 5 ms, Duty ≤ 30%	±2.0	A/phase
Power consumption <sup>Note 2</sup>	P <sub>T</sub>		1.0	W
Peak channel temperature	T <sub>CH (MAX)</sub>		150	°C
Storage temperature range	T <sub>stg</sub>		-55 to +150	°C

**Notes 1.** Allowable current per phase while on-board

2. When mounted on glass epoxy board (100 mm × 100 mm × 1 mm)

**RECOMMENDED OPERATING RANGE**

Parameter	Symbol	Conditions	MIN.	TYP.	MAX.	Unit
Supply voltage	V <sub>DD</sub>		4.5	5.0	5.5	V
	V <sub>M</sub>		10.8	12.0	13.2	V
Output current (DC)	I <sub>DR (DC)</sub>				±0.5	A/Phase
Instantaneous output current	I <sub>DR (pulse)</sub>	PW ≤ 5 ms, Duty ≤ 10%			±1.5	A/Phase
Hole bias current	I <sub>HB</sub>			10	15	mA
IND pin output current	I <sub>FG</sub>		0	±2.5	±5	mA
CL pin input voltage	V <sub>CL</sub>		0.1		0.4	V
Operating temperature range	T <sub>A</sub>		-20		75	°C

**ELECTRICAL SPECIFICATIONS (UNLESS OTHERWISE SPECIFIED, T<sub>A</sub> = 25°C, V<sub>DD</sub> = 5 V, V<sub>M</sub> = 12 V)**

Parameter	Symbol	Conditions	MIN.	TYP.	MAX.	Unit
[General]						
Current consumption 1 (during operation)	I <sub>DD</sub>	STB = V <sub>DD</sub>		1.5	3.0	mA
Current consumption (in standby)	I <sub>DD (ST)</sub>	STB = GND			1.0	μA
[ST/SP, STB, REV, FGsel]						
Input voltage, high	V <sub>IH</sub>		1.8		V <sub>DD</sub>	V
Input voltage, low	V <sub>IL</sub>				0.8	V
Input pull-down resistor	R <sub>IND</sub>			120		kΩ
[Controller block]						
Triangle wave oscillation frequency	f <sub>PWM</sub>	C <sub>T</sub> = 100 pF		75		kHz
[Hole amplifier]						
Common mode input voltage range	V <sub>Hch</sub>		1.0		3.5	V
Hysteresis voltage	V <sub>Hhys</sub>	V <sub>H</sub> = 2.5 V		15		mV
Input bias current	I <sub>Hbias</sub>				1.0	μA
[Hole bias block]						
Hole bias voltage	V <sub>HB</sub>	I <sub>HB</sub> = 10 mA		0.3	0.5	V
[FG output]						
IND-pin voltage, high	V <sub>FG_H</sub>	I <sub>FG</sub> = -2.5 mA	4.0			V
IND-pin voltage, low	V <sub>FG_L</sub>	I <sub>FG</sub> = +2.5 mA			0.5	V
[Output block]						
Output on-state resistance (upper stage + lower stage)	R <sub>ON</sub>	I <sub>DR</sub> = 200 mA T <sub>A</sub> = -20°C to +75°C		1.3	1.8	Ω
Leakage current during OFF	I <sub>DR (OFF)</sub>	In standby			10	μA
Output turn-on time	t <sub>ONH</sub>	R <sub>M</sub> = 5 Ω		1.0	2.0	μs
Output turn-off time	t <sub>OFFH</sub>	Star connection		1.0	2.0	μs
[Torque command]						
Control reference input voltage range	ECR		0.3		4.0	V
Control input voltage range	EC		0.3		4.0	V
Input current	I <sub>IN</sub>			30	50	μA
Input voltage difference	ECR-EC <sup>Note</sup>	DUTY = 100%		1.0		V
Dead zone (+)	EC_d+	1.5 V ≤ ECR ≤ 2.5 V	0	50	100	mV
Dead zone (-)	EC_d-	1.5 V ≤ ECR ≤ 2.5 V	0	-50	-100	mV
[Overcurrent detection block]						
Input offset voltage	V <sub>IO</sub>		-15		+15	mV

**Note** Dead zone not included.

- Remarks**
1. The thermal shutdown circuit (T.S.D.) operates with T<sub>CH</sub> > 150°C.
  2. The low-voltage malfunction prevention circuit (UVLO) operates with a voltage of 4 V<sub>TYP</sub>.

PIN FUNCTIONS

Package: 30-pin Shrink SOP (300 mil)

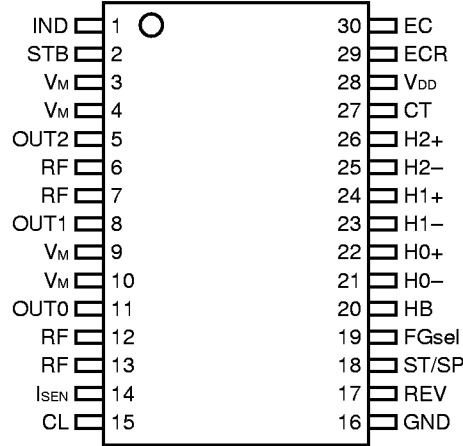

Pin No.	Pin Name	Pin Function
1	IND	Index signal output pin
2	STB	Standby operation input pin
3	V <sub>M</sub>	Supply input pin for motor block (12 V)
4	V <sub>M</sub>	Supply input pin for motor block (12 V)
5	OUT2	Motor connection pin
6	RF	3-phase bridge common pin
7	RF	3-phase bridge common pin
8	OUT1	Motor connection pin
9	V <sub>M</sub>	Supply input pin for motor block (12 V)
10	V <sub>M</sub>	Supply input pin for motor block (12 V)
11	OUT0	Motor connection pin
12	RF	3-phase bridge common pin
13	RF	3-phase bridge common pin
14	I <sub>SEN</sub>	Sense resistor connection pin
15	CL	Overcurrent detection voltage input pin
16	GND	GND pin
17	REV	Reverse rotation input pin (reverse brake pin)
18	ST/SP	Start/stop input pin
19	FGsel	IND pulse selection pin
20	HB	Hole bias pin
21	H0-	Hole signal input pin
22	H0+	Hole signal input pin
23	H1-	Hole signal input pin
24	H1+	Hole signal input pin
25	H2-	Hole signal input pin
26	H2+	Hole signal input pin
27	CT	Oscillation frequency setup capacitor connection pin
28	V <sub>DD</sub>	Controller block supply input pin (5 V)
29	ECR	Control reference voltage input pin
30	EC	Control voltage input pin

**Caution** When there is more than one pin of the same kind of pin (V<sub>M</sub> and RF), all pins should be connected to their targets.

BLOCK DIAGRAM

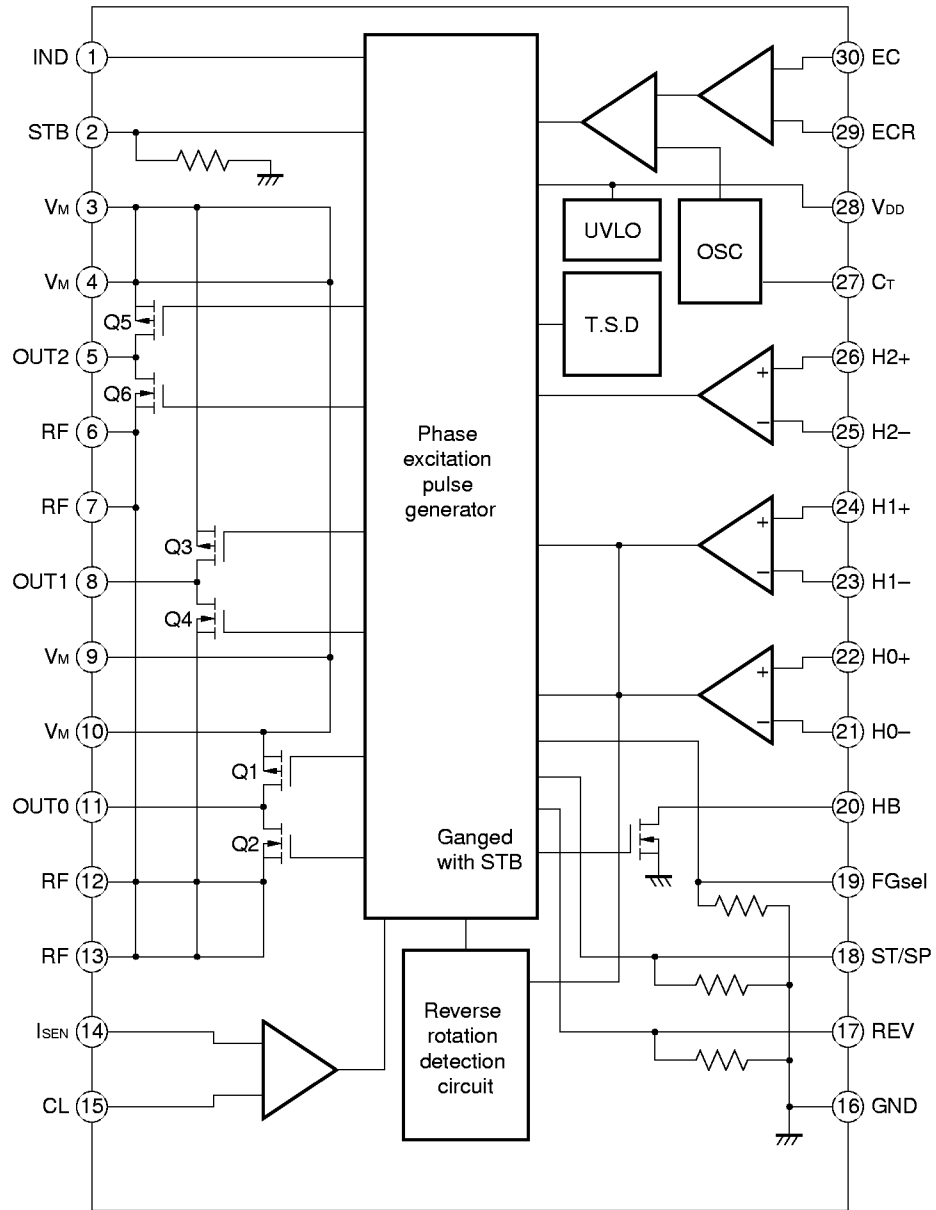

**Caution** When there is more than one pin of the same kind of pin (VM and RF), all pins should be connected to their targets.

TOTAL POWER DISSIPATION VS. AMBIENT TEMPERATURE CHARACTERISTICS

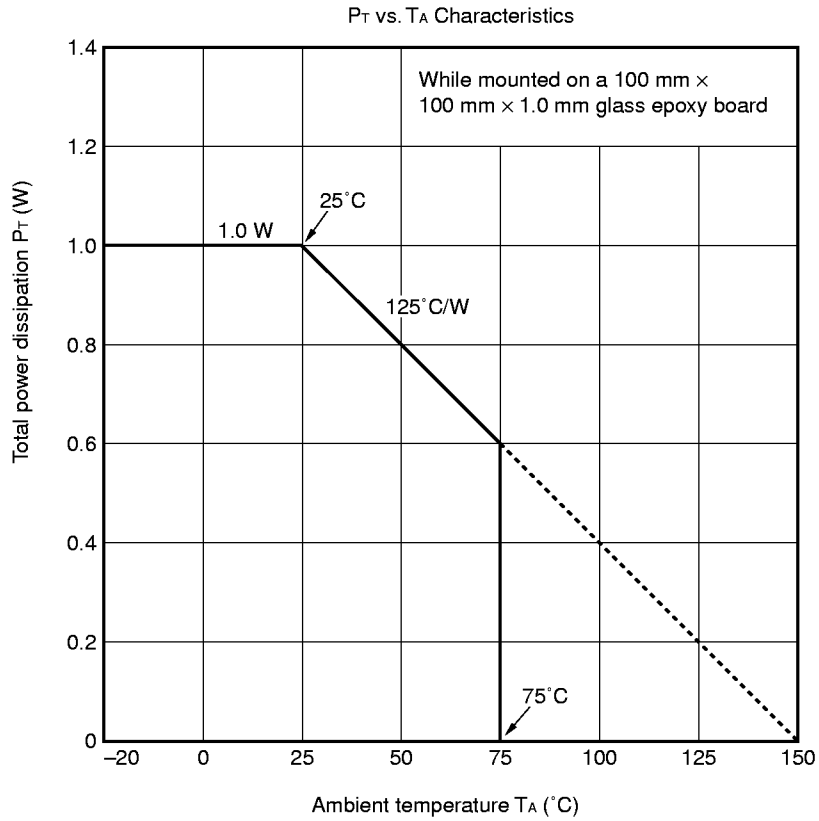

**Remark** It is possible to apply a maximum of 1 W of power when the ambient temperature is 25°C or lower. When the ambient temperature is higher than 25°C, derate based on the above chart. It is possible to apply 0.6 W to the IC when the ambient temperature is 75°C, which is within recommended ambient temperature conditions.

STANDARD CHARACTERISTICS CURVES (UNLESS OTHERWISE SPECIFIED,  $T_A = 25^\circ\text{C}$ )

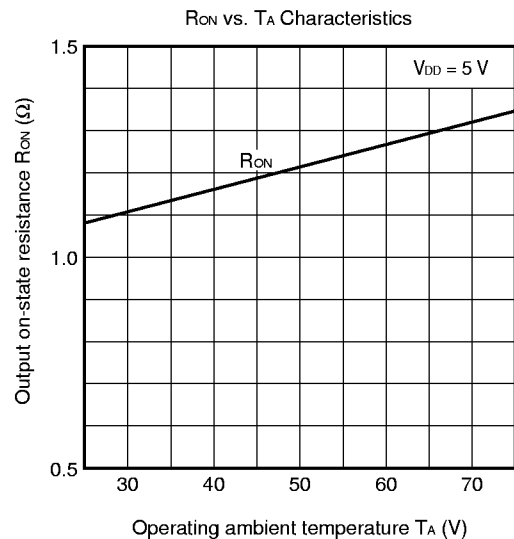
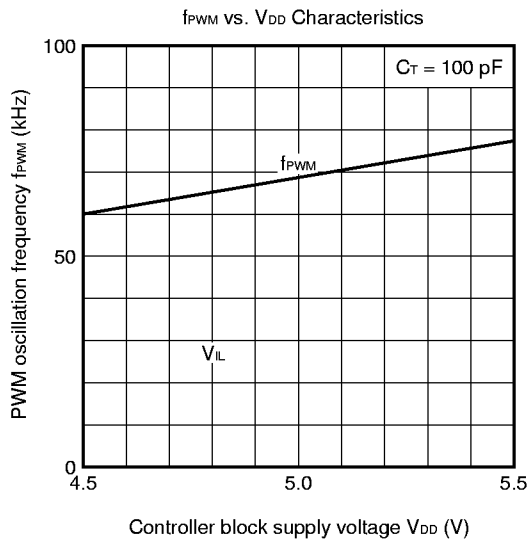
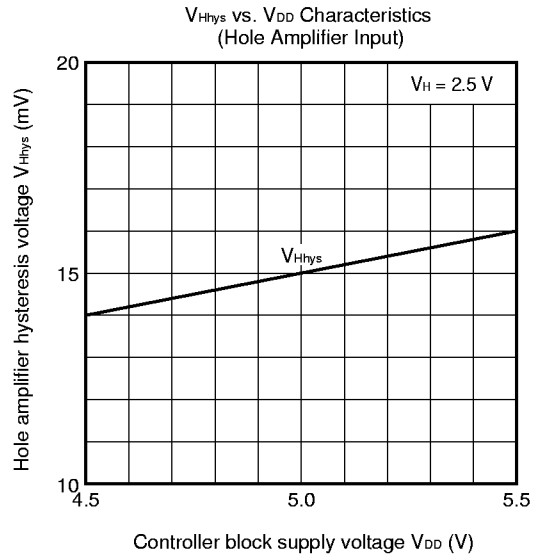
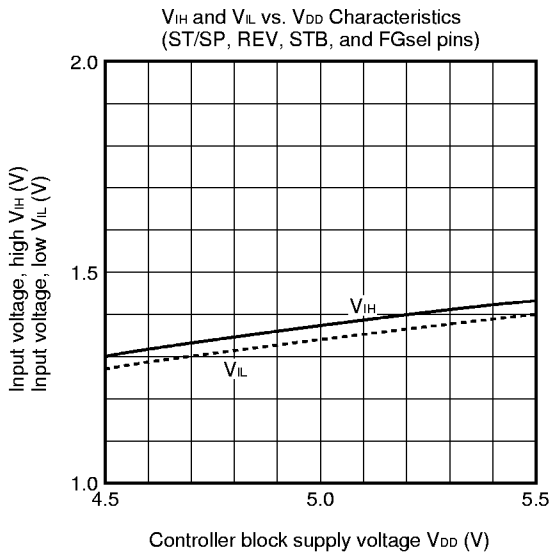
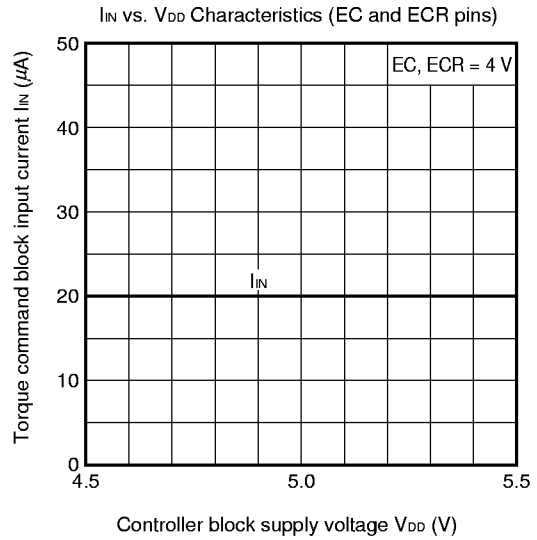
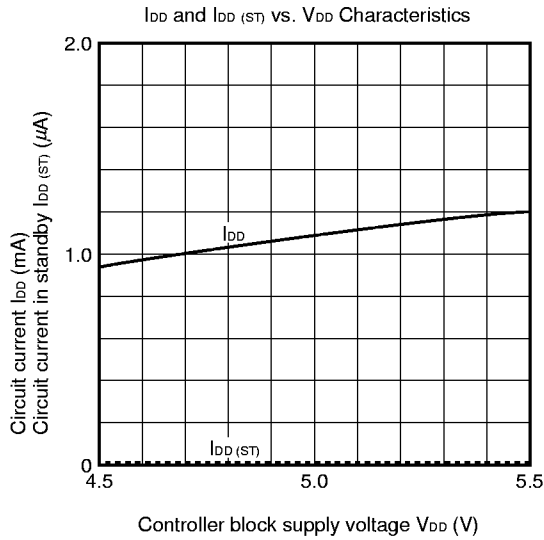

**FUNCTION OPERATION TABLE**

**(1) ST/SP = "H"**

Input Signal				Circuit Operation Mode	Source → Sink
CMP0	CMP1	CMP2	PWM		
H	H	L	H	Operation	W → V
H	H	L	L	Brake	
H	L	L	H	Operation	W → U
H	L	L	L	Brake	
H	L	H	H	Operation	V → U
H	L	H	L	Brake	
L	L	H	H	Operation	V → W
L	L	H	L	Brake	
L	H	H	H	Operation	U → W
L	H	H	L	Brake	
L	H	L	H	Operation	U → V
L	H	L	L	Brake	

Brake: Regenerates via the high-side Pch MOS FET channel.

**(2) ST/SP = "L"**

Input Signal				Circuit Operation Mode
CMP0	CMP1	CMP2	PWM	
-	-	-	-	Short brake

Short brake: Turns the high-side MOS FET on and the low-side MOS FET off.

**(3) Torque Command**

The curve shown below is the relationship to torque of the difference (ECR – EC) between the control reference voltage (ECR) and the control voltage (EC).

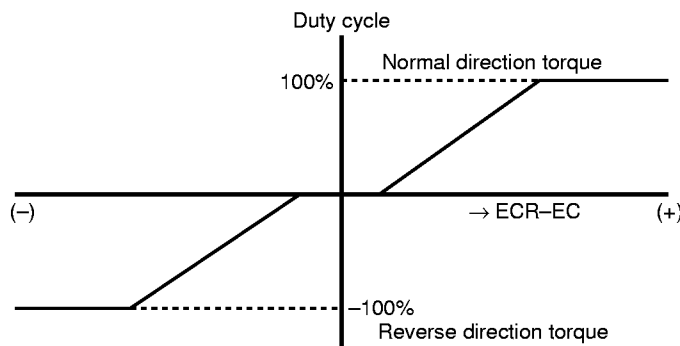

	Reverse Rotation Pin Voltage (REV)	
	L	H
ECR > EC	Normal rotation	Reverse rotation <sup>Note</sup>
ECR < EC	Reverse rotation <sup>Note</sup>	Stop

**Note** Stops after detecting reverse rotation  
The reverse drive current flows in the high-side Pch MOS FET channel on reverse rotation.

**(4) Standby Mode**

The setting of the standby mode allows the power supply in the device to be turned off forcibly.

The status of outputs from pins in standby is high impedance (H-bridge all OFF). In addition it is possible to reduce the circuit current since the internal oscillation block stops.

When the stop operation is executed by the standby pin during normal operation, the motor is stopped by inertia force.

When the normal status is reset, it takes several tens of μs to be activated.

STB Pin	Operation Mode
H	Normal operation mode
L	Standby mode

TIMING CHART

(1) Hole Signal Input

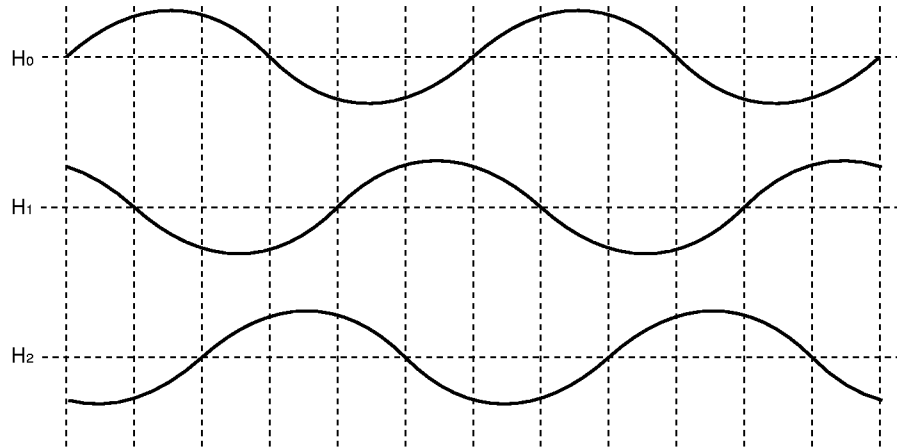

(2) CMP Signal (FGsel = L: IND1, FGsel = H: IND2)

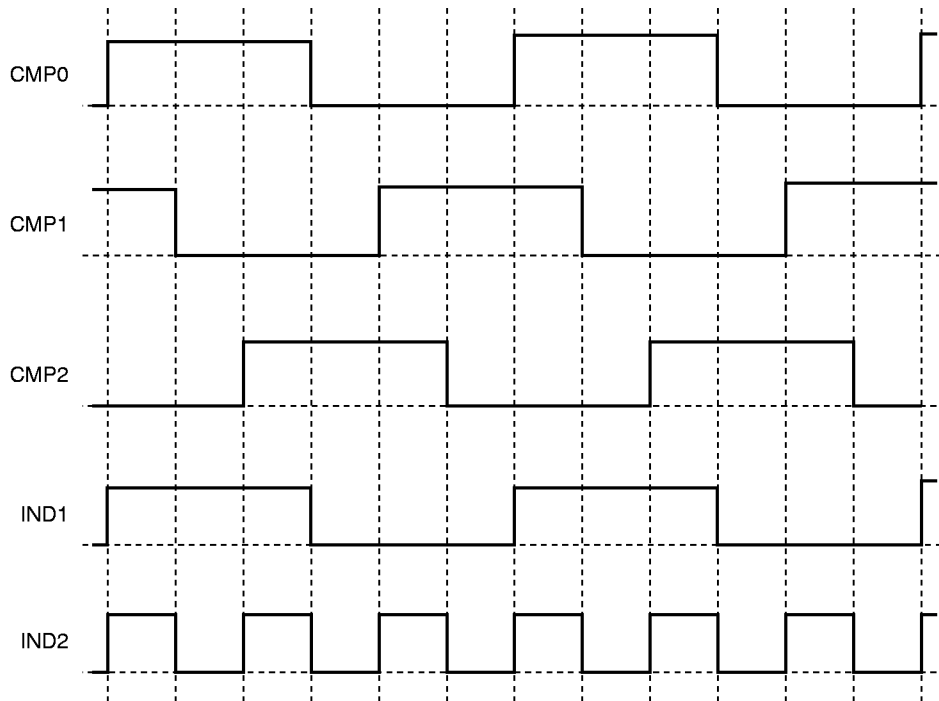

(3) Selection of Output MOS FET Drive and Comparator (A Blank Indicates Switch OFF)

Q1	$\overline{SW}$	$\overline{SW}$		ON	ON		$\overline{SW}$	$\overline{SW}$		ON	ON		
Q2	SW	SW					SW	SW					
Q3	$\overline{SW}$		ON	ON		$\overline{SW}$	$\overline{SW}$		ON	ON		$\overline{SW}$	$\overline{SW}$
Q4	SW					SW	SW					SW	SW
Q5	ON	ON		$\overline{SW}$	$\overline{SW}$		ON	ON		$\overline{SW}$	$\overline{SW}$		ON
Q6				SW	SW					SW	SW		

(4) Motor Drive Waveform

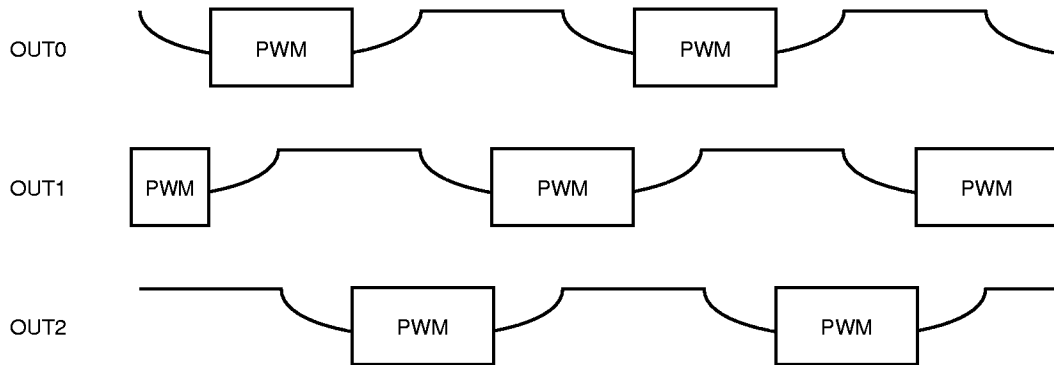

APPLICATION CIRCUIT EXAMPLE

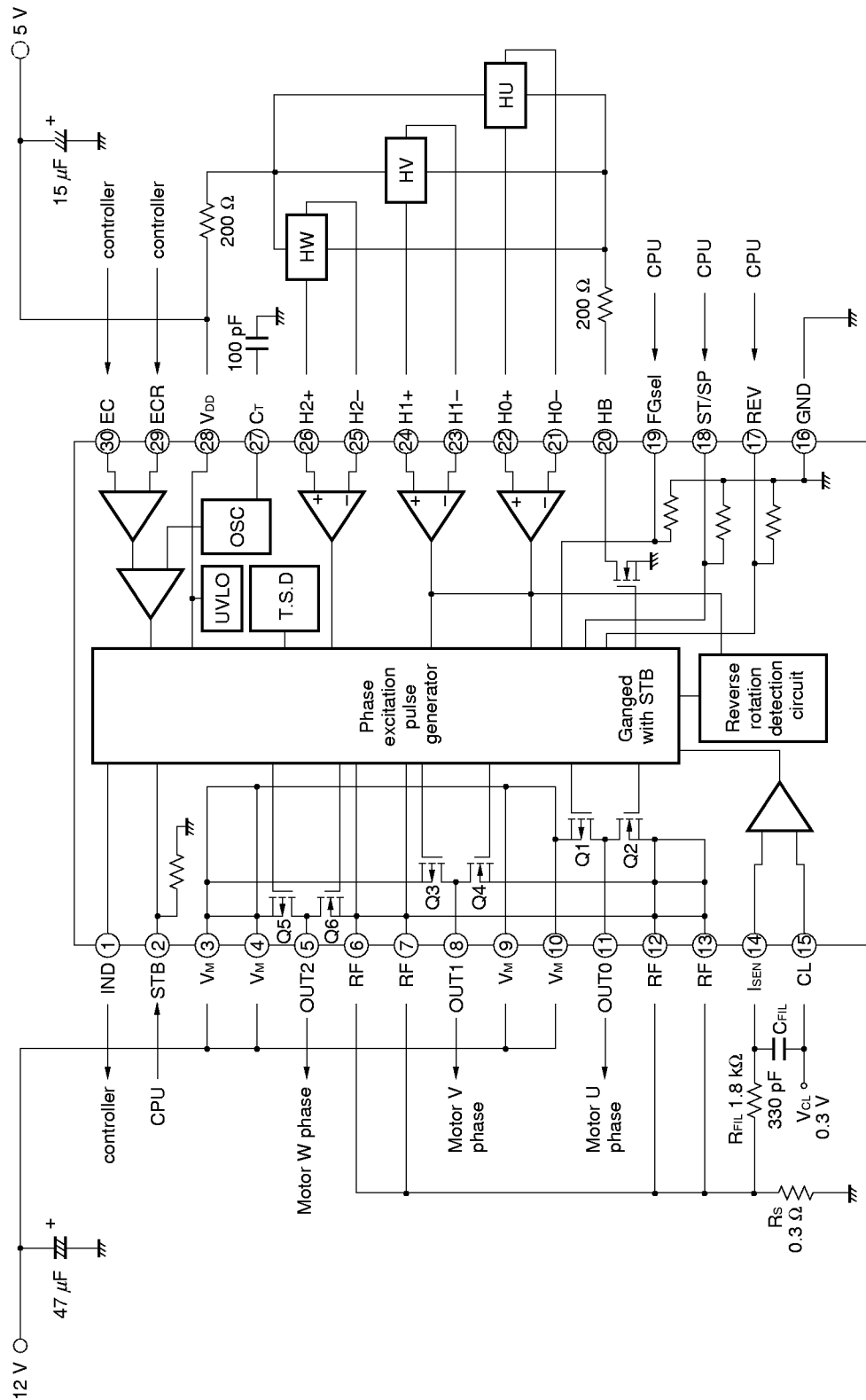

**Remark** To eliminate noise during PWM, it is recommended to insert a tantalum capacitor between VM and GND (47 μF in the above figure).  
 Moreover, set V<sub>CL</sub> and R<sub>s</sub> to values within the ratings.  
 This circuit is for reference only and is not intended for use in mass production.

PACKAGE DRAWING

30-Pin Plastic Shrink SOP (300 mil) (Unit: mm)

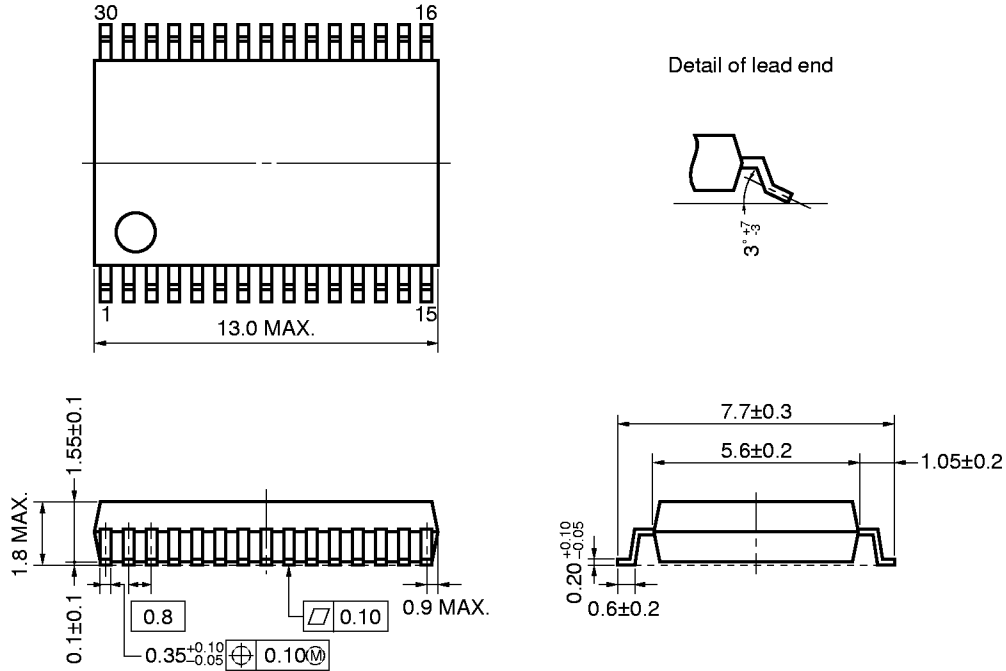

**RECOMMENDED SOLDERING CONDITIONS**

μPD16856 should be soldered and mounted under the following recommended conditions. For soldering methods and conditions other than those recommended below, contact your NEC sales representative.

- For the details of the recommended soldering conditions, refer to the document **Semiconductor Device Mounting Technology Manual (C10535E)**.

Soldering Method	Soldering Conditions	Recommended Condition Symbol
Infrared reflow	Package peak temperature: 235°C, Time: 30 sec. Max. (at 210°C or higher), Count: three times or less, Exposure limit: none <sup>Note</sup> , Flux: Rosin-based flux with little chlorine content (chlorine: 0.2 Wt% Max.) is recommended	IR35-00-3
VPS	Package peak temperature: 215°C, Time: 40 sec. Max. (at 200°C or higher), Count: three times or less, Exposure limit: none <sup>Note</sup> , Flux: Rosin-based flux with little chlorine content (chlorine: 0.2 Wt% Max.) is recommended	VP15-00-3
Wave soldering	Package peak temperature: 260°C, Time: 10 sec. Max., Proheating temperature: 120°C Max., Count: once, Flux: Rosin-based flux with little chlorine content (chlorine: 0.2 Wt% Max.) is recommended	WS60-00-1

**Note** After opening the dry pack, store it at 25°C or less and 65% RH or less for the allowable storage period.

**Caution** Do not use different soldering methods together.