

LINE BUFFER
5K-WORD BY 8-BIT**Description**

The μ PD485505 is a 5,048 words by 8 bits high speed FIFO (First In First Out) line buffer. Its CMOS static circuitry provides high speed access and low power consumption.

The μ PD485505 can be used for one line delay and time axis conversion in high speed facsimile machines and digital copiers.

Moreover, the μ PD485505 can execute read and write operations independently on an asynchronous basis. Thus the μ PD485505 is suitable as a buffer for data transfer between units with different transfer rates and as a buffer for the synchronization of multiple input signals. There are three versions, E, K, P, and L. This data sheet can be applied to the version P and L. These versions operate with different specifications. Each version is identified with its lot number (refer to **7. Example of Stamping**).

Features

- 5,048 words by 8 bits
- Asynchronous read/write operations available
- Variable length delay bits; 21 to 5,048 bits (Cycle time: 25 ns)
15 to 5,048 bits (Cycle time: 35 ns)
- Power supply voltage $V_{CC} = 5.0 V \pm 0.5 V$
- Suitable for sampling one line of A3 size paper (16 dots/mm)
- All input/output TTL compatible
- 3-state output
- Full static operation; data hold time = infinity

Ordering Information

Part Number	R/W Cycle Time	Package
μ PD485505G-25	25 ns	24-pin plastic SOP (11.43 mm (450))
μ PD485505G-35	35 ns	

The information in this document is subject to change without notice. Before using this document, please confirm that this is the latest version.

Not all devices/types available in every country. Please check with local NEC representative for availability and additional information.

★ Pin Configuration (Marking side)

24-pin plastic SOP (11.43 mm (450))
[μPD485505G]

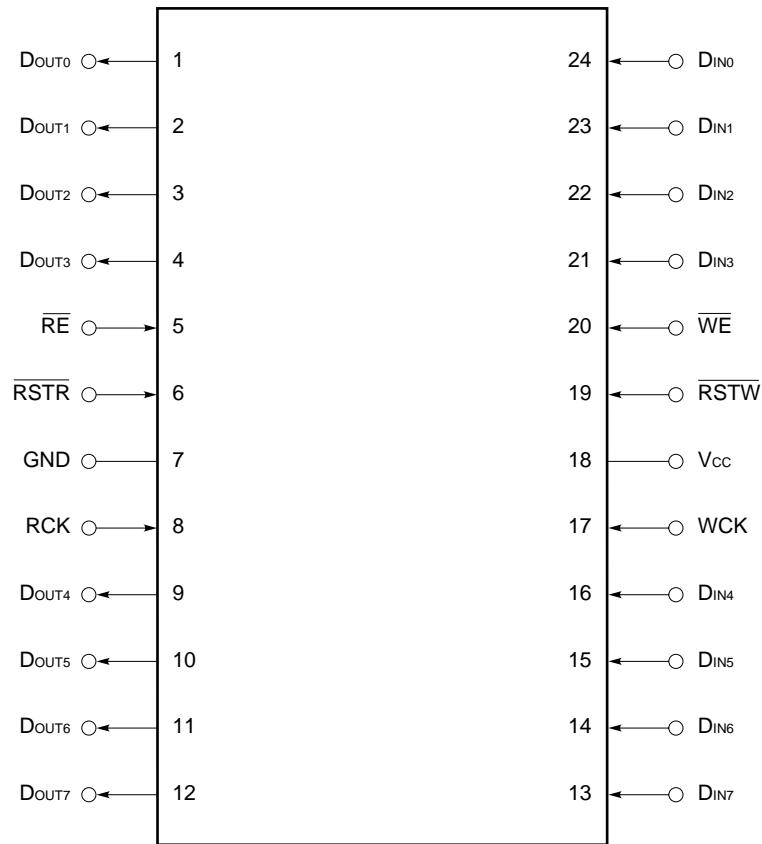

- DIN0 - DIN7 : Data Inputs
- DOUT0 - DOUT7 : Data Outputs
- WCK : Write Clock Input
- RCK : Read Clock Input
- WE : Write Enable Input
- RE : Read Enable Input
- RSTW : Reset Write Input
- RSTR : Reset Read Input
- VCC : +5.0 V Power Supply
- GND : Ground

Remark Refer to **5. Package Drawing** for the 1-pin index mark.

Block Diagram

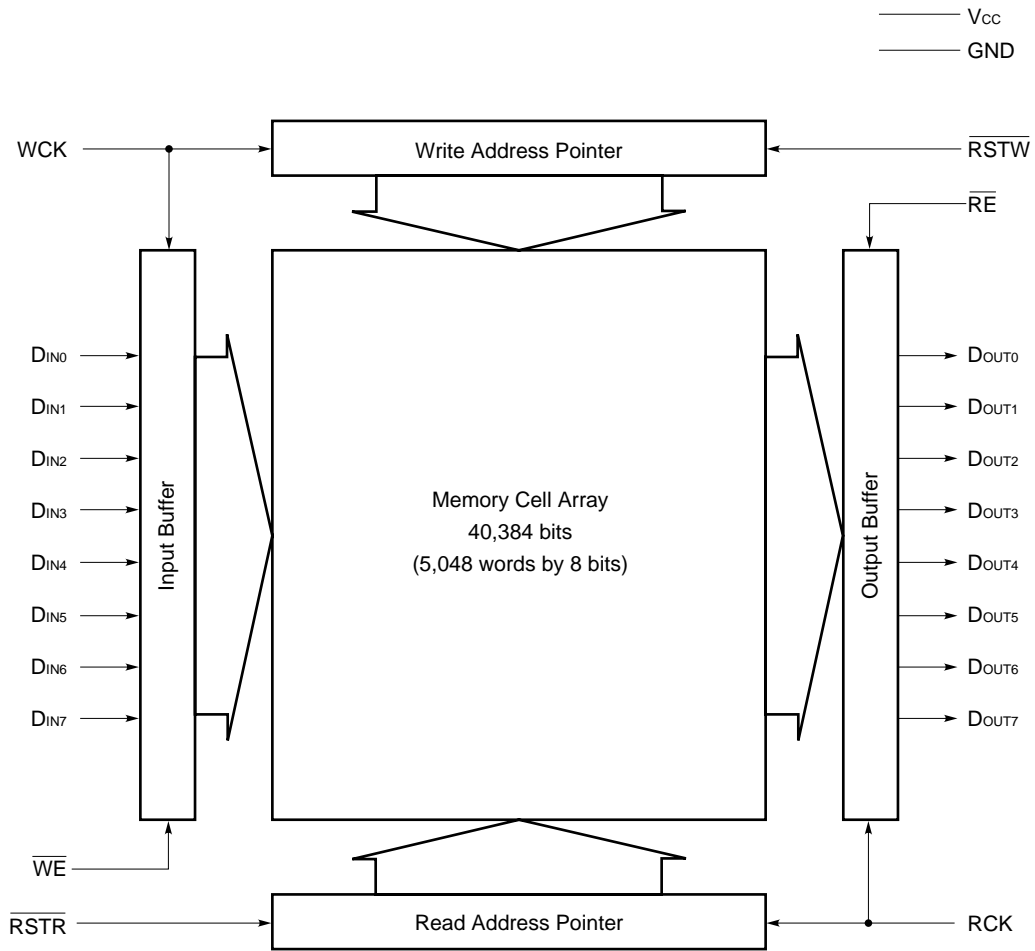

1. Input/Output Pin Function

Pin			I/O	Function
Pin Number	Symbol	Pin Name		
24 - 21 16 - 13	D _{IN0} D _{IN7}	Data Input	In	Write data input pins. The data inputs are strobed by the rising edge of WCK at the end of a cycle and the setup and hold times (t_{DS} , t_{DH}) are defined at this point.
1 - 4 9 - 12	D _{OUT0} D _{OUT7}	Data Output	Out	Read data output pins. The access time is regulated from the rising edge of RCK at the beginning of a cycle and defined by t_{AC} .
19	\overline{RSTW}	Reset Write Input	In	Reset input pin for the initialization of the write address pointer. The state of \overline{RSTW} is strobed by the rising edge of WCK at the beginning of a cycle and the setup and hold times (t_{RS} , t_{RH}) are defined.
6	\overline{RSTR}	Reset Read Input	In	Reset input pin for the initialization of the read address pointer. The state of \overline{RSTR} is strobed by the rising edge of RCK at the beginning of a cycle and the setup and hold times (t_{RS} , t_{RH}) are defined.
20	\overline{WE}	Write Enable Input	In	Write operation control signal input pin. When \overline{WE} is in the disable mode ("H" level), the internal write operation is inhibited and the write address pointer stops at the current position.
5	\overline{RE}	Read Enable Input	In	Read operation control signal input pin. When \overline{RE} is in the disable mode ("H" level), the internal read operation is inhibited and the read address pointer stops at the current position. The output changes to high impedance.
17	WCK	Write Clock Input	In	Write clock input pin. When \overline{WE} is enabled ("L" level), the write operation is executed in synchronization with the write clock. The write address pointer is incremented simultaneously.
8	RCK	Read Clock Input	In	Read clock input pin. When \overline{RE} is enabled ("L" level), the read operation is executed in synchronization with the read clock. The read address pointer is incremented simultaneously.

2. Operation Mode

μ PD485505 is a synchronous memory. All signals are strobed at the rising edge of the clock (RCK, WCK). For this reason, setup time and hold time are specified for the rising edge of the clock (RCK, WCK).

2.1 Write Cycle

When the \overline{WE} input is enabled ("L" level), a write cycle is executed in synchronization with the WCK clock input.

The data inputs are strobed by the rising edge of the clock at the end of a cycle so that read data after a one-line (5,048 bits) delay and write data can be processed with the same clock. Refer to Write Cycle Timing Chart.

When \overline{WE} is disabled ("H" level) in a write cycle, the write operation is not performed during the cycle which the WCK rising edge is in the $\overline{WE} = "H"$ level (t_{WEW}). The WCK does not increment the write address pointer at this time.

Unless inhibited by \overline{WE} , the internal write address will automatically wrap around from 5,047 to 0 and begin incrementing again.

2.2 Read Cycle

When the \overline{RE} input is enabled ("L" level), a read cycle is executed in synchronization with the RCK clock input and data is output after t_{AC} . Refer to Read Cycle Timing Chart.

When \overline{RE} is disabled ("H" level) in a read cycle, the read operation is not performed during the cycle which the RCK rising edge is in the $\overline{RE} = "H"$ level (t_{REW}). The RCK does not increment the read address pointer at this time.

2.3 Write Reset Cycle/Read Reset Cycle

After power up, the μ PD485505 requires the initialization of internal circuits because the read and write address pointers are not defined at that time.

It is necessary to satisfy setup requirements and hold times as measured from the rising edge of WCK and RCK, and then input the \overline{RSTW} and \overline{RSTR} signals to initialize the circuit.

Write and read reset cycles can be executed at any time and the address pointer returns zero. Refer to Write Reset Cycle Timing Chart, Read Reset Cycle Timing Chart.

Remark Write and read reset cycles can be executed at any time and do not depend on the state of \overline{RE} or \overline{WE} .

Operation-related Restriction

Following restriction exists to read data written in a write cycle.

Read the written data after an elapse of $1/2$ write cycle + t_{WAR} since the write cycle ends (see **Figure 2.1**).

If t_{WAR} is not satisfied, the output data may undefined.

Figure 2.1 Delay Bits Restriction Timing Chart

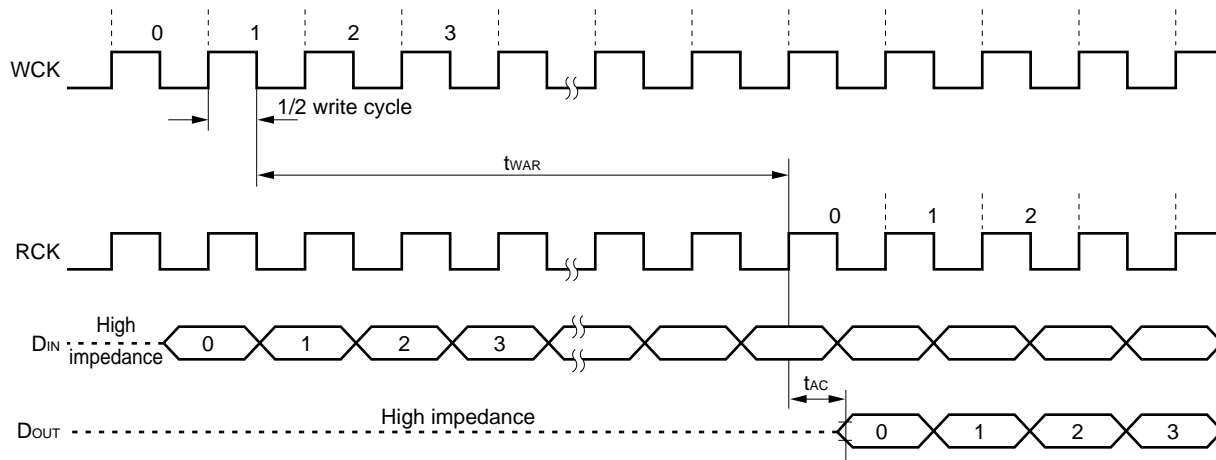

Remark This timing chart describes only the delay bits restriction, and does not defines the \overline{WE} , \overline{RE} , \overline{RSTW} , \overline{RSTR} signals.

3. Electrical Specifications

All voltages are referenced to GND.

Absolute Maximum Ratings

Parameter	Symbol	Condition	Rating	Unit
Voltage on any pin relative to GND	V_T		-0.5 ^{Note} to $V_{CC} + 0.5$	V
Supply voltage	V_{CC}		-0.5 to +7.0	V
Output current	I_o		20	mA
Operating ambient temperature	T_A		0 to 70	°C
Storage temperature	T_{stg}		-55 to +125	°C

Note -3.0 V MIN. (Pulse width = 10 ns)

Caution Exposing the device to stress above those listed in Absolute Maximum Ratings could cause permanent damage. The device is not meant to be operated under conditions outside the limits described in the operational section of this specification. Exposure to Absolute Maximum Rating conditions for extended periods may affect device reliability.

Recommended Operating Conditions

Parameter	Symbol	Condition	MIN.	TYP.	MAX.	Unit
Supply voltage	V_{CC}		4.5	5.0	5.5	V
High level input voltage	V_{IH}		2.4		$V_{CC} + 0.5$	V
Low level input voltage	V_{IL}		-0.3 ^{Note}		+0.8	V
Operating ambient temperature	T_A		0		70	°C

Note -3.0 V MIN. (Pulse width = 10 ns)

DC Characteristics (Recommended Operating Conditions unless otherwise noted)

Parameter	Symbol	Test Condition	MIN.	TYP.	MAX.	Unit
Operating current	I_{CC}				80	mA
Input leakage current	I_i	$V_i = 0$ to V_{CC} , Other Input 0 V	-10		+10	μA
Output leakage current	I_o	$V_o = 0$ to V_{CC} , DOUT: High impedance	-10		+10	μA
High level output voltage	V_{OH}	$I_{OH} = -1$ mA	2.4			V
Low level output voltage	V_{OL}	$I_{OL} = 2$ mA			0.4	V

Capacitance ($T_A = 25$ °C, $f = 1$ MHz)

Parameter	Symbol	Test Condition	MIN.	TYP.	MAX.	Unit
Input capacitance	C_i				10	pF
Output capacitance	C_o				10	pF

AC Characteristics (Recommended Operating Conditions unless otherwise noted)Notes 1, 2, 3

Parameter	Symbol	μPD485505-25		μPD485505-35		Unit	Notes
		MIN.	MAX.	MIN.	MAX.		
Write clock cycle time	t _{WCK}	25		35		ns	
Write clock pulse width	t _{WCW}	11		12		ns	
Write clock precharge time	t _{WCP}	11		12		ns	
Read clock cycle time	t _{RCK}	25		35		ns	
Read clock pulse width	t _{RCW}	11		12		ns	
Read clock precharge time	t _{RCP}	11		12		ns	
Access time	t _{AC}		18		25	ns	
Write data-read delay time	t _{WAR}	470		470		ns	
Output hold time	t _{OH}	5		5		ns	
Output low-impedance time	t _{LZ}	5	18	5	25	ns	4
Output high-impedance time	t _{HZ}	5	18	5	25	ns	4
Input data setup time	t _{DS}	7		10		ns	
Input data hold time	t _{DH}	3		3		ns	
RSTW/RSTR Setup time	t _{RS}	7		10		ns	5
RSTW/RSTR Hold time	t _{RH}	3		3		ns	5
RSTW/RSTR Deselected time (1)	t _{RN1}	3		3		ns	6
RSTW/RSTR Deselected time (2)	t _{RN2}	7		10		ns	6
WE Setup time	t _{WES}	7		10		ns	7
WE Hold time	t _{WEH}	3		3		ns	7
WE Deselected time (1)	t _{WEN1}	3		3		ns	8
WE Deselected time (2)	t _{WEN2}	7		10		ns	8
RE Setup time	t _{RES}	7		10		ns	9
RE Hold time	t _{REH}	3		3		ns	9
RE Deselected time (1)	t _{REN1}	3		3		ns	10
RE Deselected time (2)	t _{REN2}	7		10		ns	10
WE Disable time	t _{WEW}	0		0		ms	
RE Disable time	t _{REW}	0		0		ms	
Write reset time	t _{RSTW}	0		0		ms	
Read reset time	t _{RSTR}	0		0		ms	
Transition time	t _T	3	35	3	35	ns	

- Notes**
1. AC measurements assume $t_r = 5 \text{ ns}$.
 2. AC Characteristics test condition

Input Timing Specification

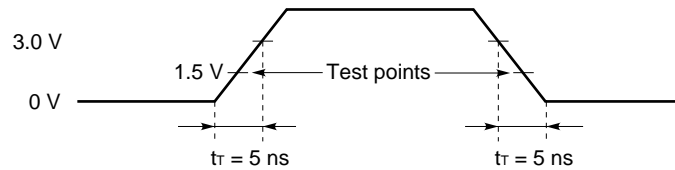

Output Timing Specification

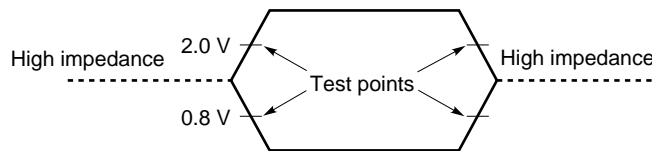

Output Loads for Timing

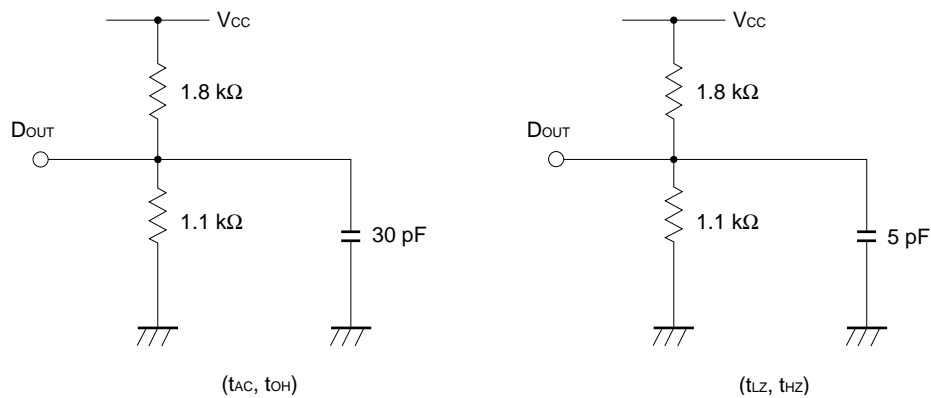

3. Input timing reference levels = 1.5 V. Output timing reference levels; $V_{OH} = 2.0 \text{ V}$, $V_{OL} = 0.8 \text{ V}$.
4. t_{LZ} and t_{HZ} are measured at $\pm 200 \text{ mV}$ from the steady state voltage. Under any conditions, $t_{LZ} \geq t_{HZ}$.
5. If either t_{RS} or t_{RH} is less than the specified value, reset operations are not guaranteed.
6. If either t_{RN1} or t_{RN2} is less than the specified value, reset operations may extend to cycles preceding or following the period of reset operations.
7. If either t_{WES} or t_{WEH} is less than the specified value, write disable operations are not guaranteed.
8. If either t_{WEN1} or t_{WEN2} is less than the specified value, internal write disable operations may extend to cycles preceding or following the period of write disable operations.
9. If either t_{RES} or t_{REH} is less than the specified value, read disable operations are not guaranteed.
10. If either t_{REN1} or t_{REN2} is less than the specified value, internal read disable operations may extend to cycles preceding or following the period of read disable operations.

Write Cycle Timing Chart

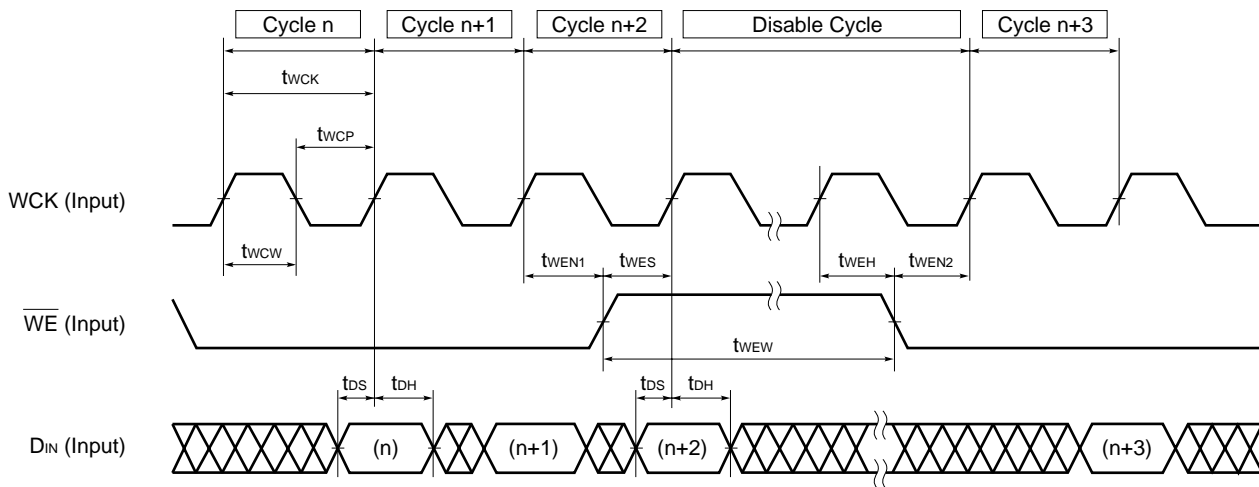

Remark \overline{RSTW} = "H" level

Read Cycle Timing Chart

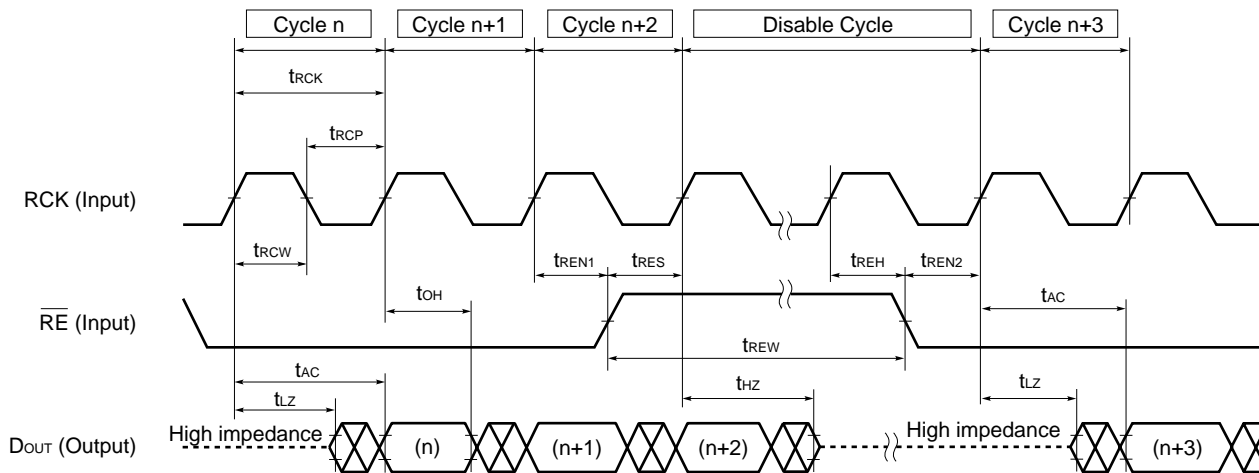

Remark \overline{RSTR} = "H" level

Write Reset Cycle Timing Chart (\overline{WE} = Active)

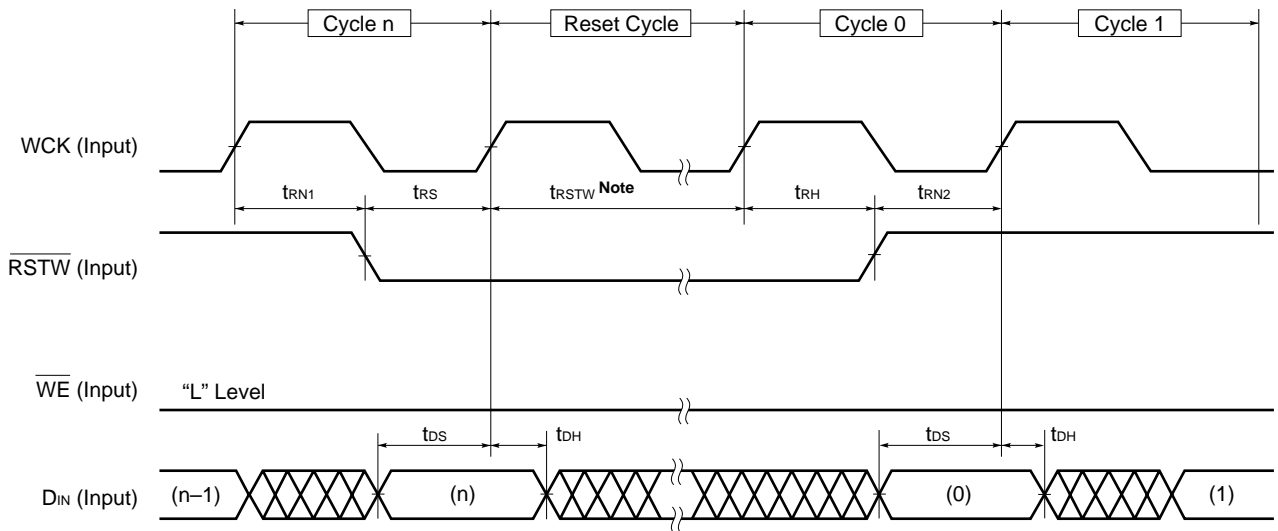

Note In write reset cycle, reset operation is executed even without a reset cycle (t_{RSTW}).
WCK can be input any number of times in a reset cycle.

Write Reset Cycle Timing Chart (\overline{WE} = Inactive)

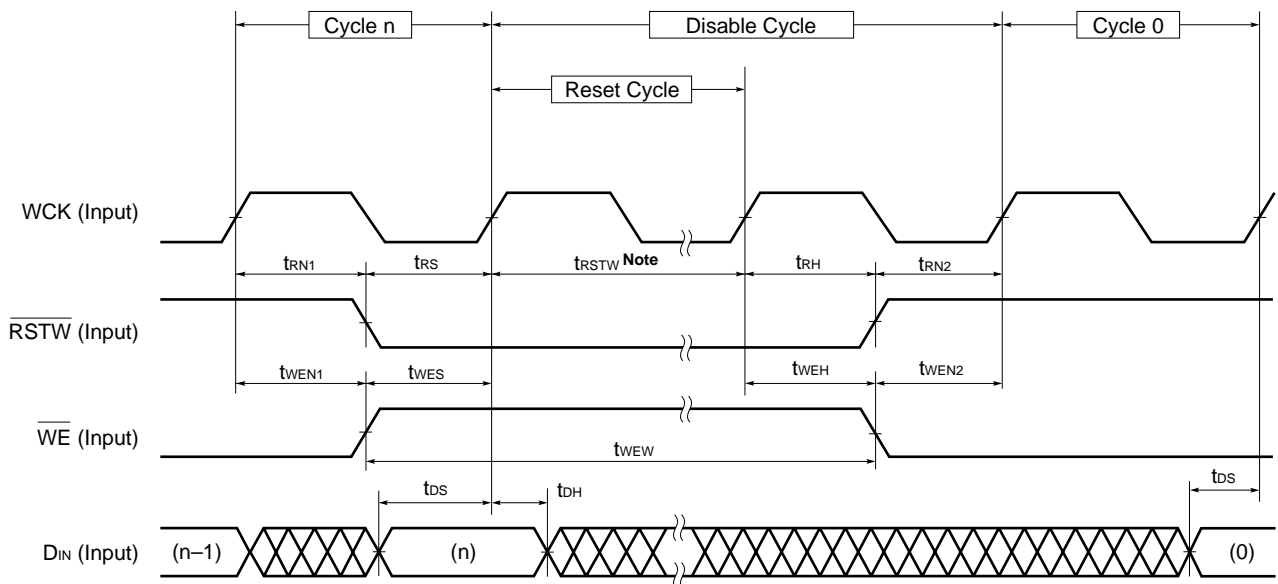

Note In write reset cycle, reset operation is executed even without a reset cycle (t_{RSTW}).
WCK can be input any number of times in a reset cycle.

Read Reset Cycle Timing Chart ($\overline{RE} = \text{Active}$)

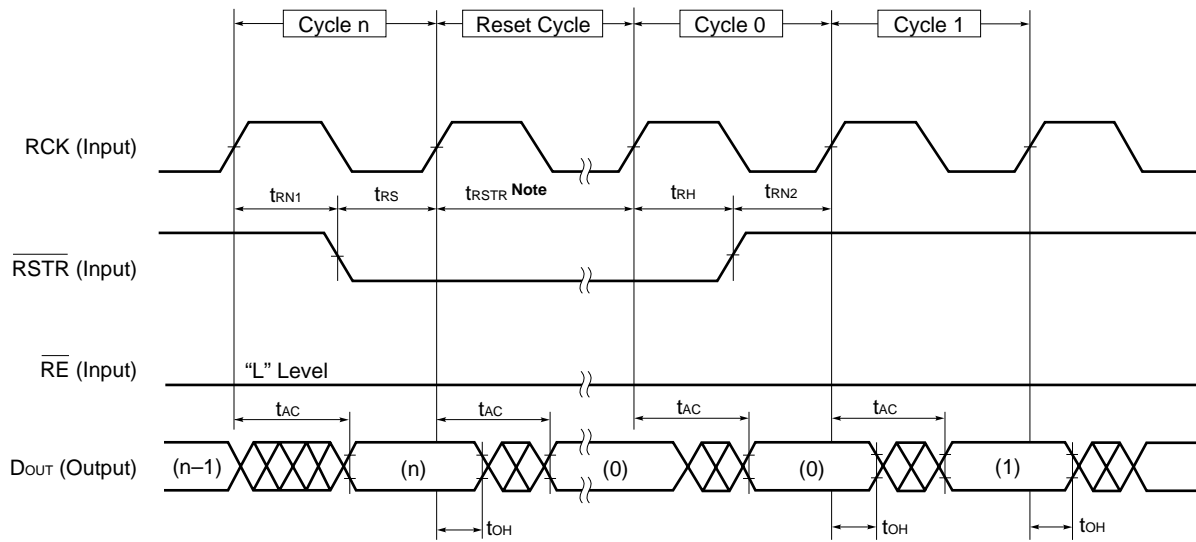

Note In read reset cycle, reset operation is executed even without a reset cycle (t_{RSTR}).
RCK can be input any number of times in a reset cycle.

Read Reset Cycle Timing Chart ($\overline{RE} = \text{Inactive}$)

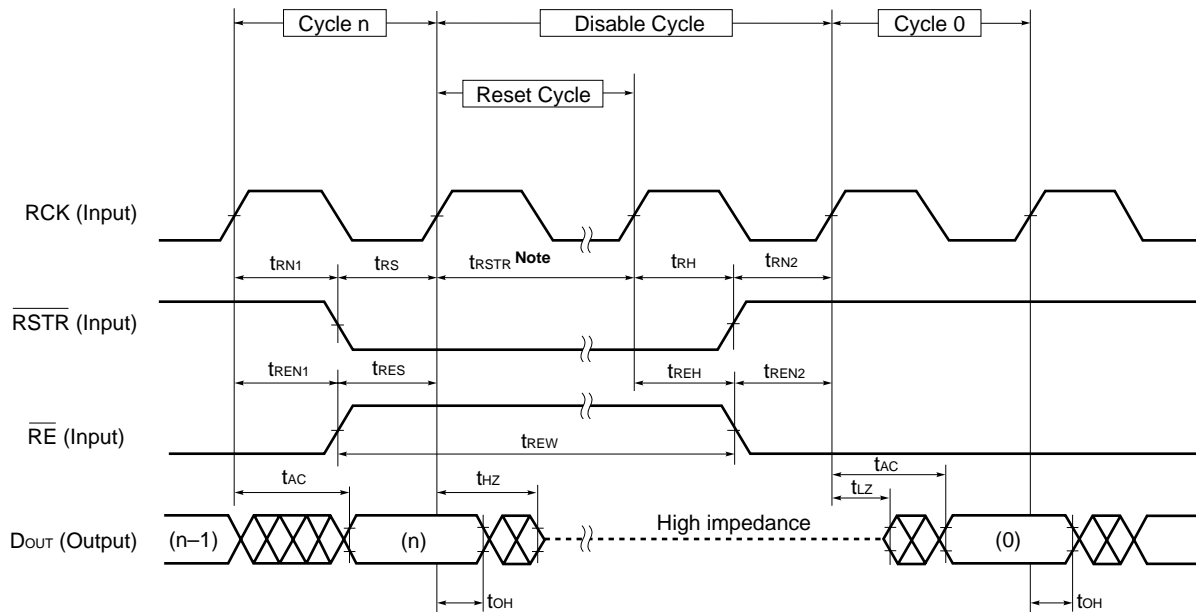

Note In read reset cycle, reset operation is executed even without a reset cycle (t_{RSTR}).
RCK can be input any number of times in a reset cycle.

4.2 n Bit Delay

It is possible to make delay read from the write data with the μPD485505.

- (1) Perform a reset operation in the cycle proportionate to the delay length. (Figure 4.3)
- (2) Shift the input timing of write reset (\overline{RSTW}) and read reset (\overline{RSTR}) depending on the delay length. (Figure 4.4)
- (3) Shift the address by disabling \overline{RE} for the period proportionate to the delay length. (Figure 4.5)

n bit: Delay bits from write cycle to read cycle correspond to a same address cell.

Restrictions

Delay bits n can be set from minimum bits to maximum bits depending on the operating cycle time. Refer to 2. Operation Mode Operation-related Restriction.

Cycle time	MIN.	MAX.
25 ns	21 bits	5,048 bits
35 ns	15 bits	5,048 bits

Figure 4.3 n-Bit Delay Line Timing Chart (1)

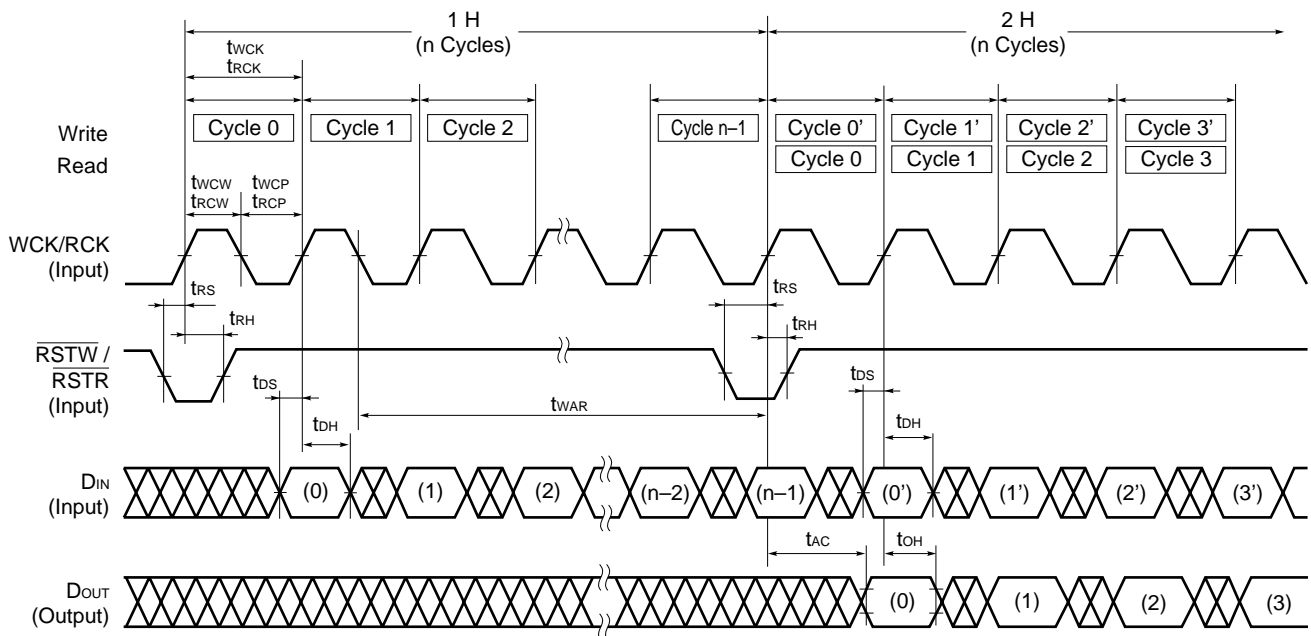

Remark \overline{RE} , \overline{WE} = "L" level

Figure 4.4 n-Bit Delay Line Timing Chart (2)

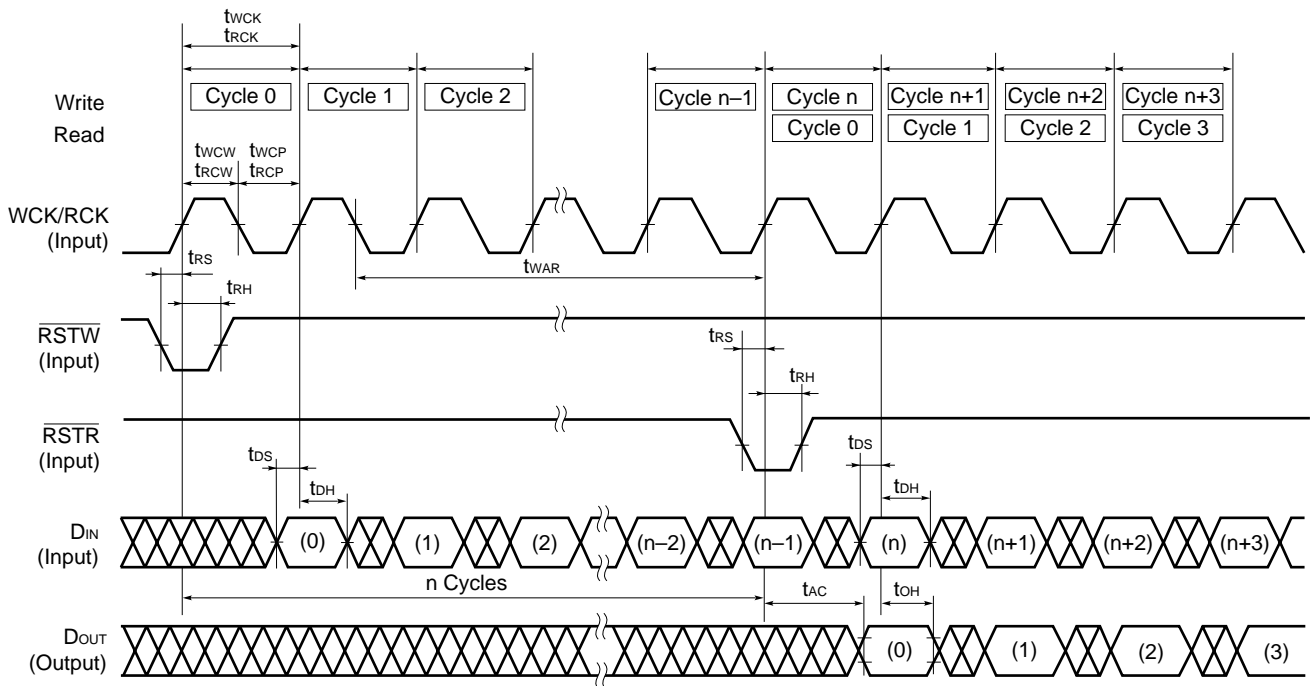

Remark \overline{RE} , \overline{WE} = "L" level

Figure 4.5 n-Bit Delay Line Timing Chart (3)

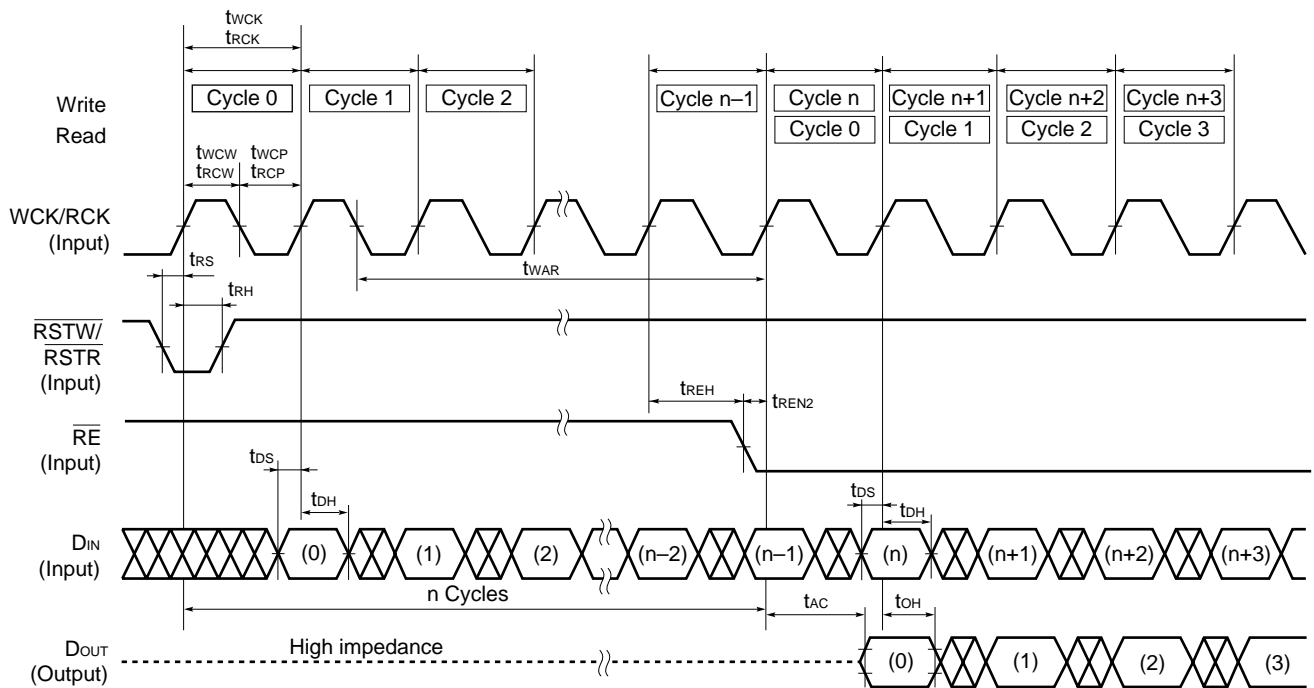

Remark \overline{WE} = "L" level

4.3 Double-speed Conversion

Figure 4.6 shows an example timing chart of double-speed and twice reading operation ($f_R = 2f_W$, 5,048 by 2 cycle) for a write operation ($f_W = 5,048$ cycle).

Caution The read operation collide with the write operation on the same line, last n bits output data (5,048–n to 5,048) in the first read operation will be undefined (see Figure 4.6 Double-speed Conversion Timing Chart).

Undefined bits mentioned above depend on the cycle time.

Read cycle time	Undefined bits
25 ns	21 bits
35 ns	15 bits

Figure 4.6 Double-speed Conversion Timing Chart

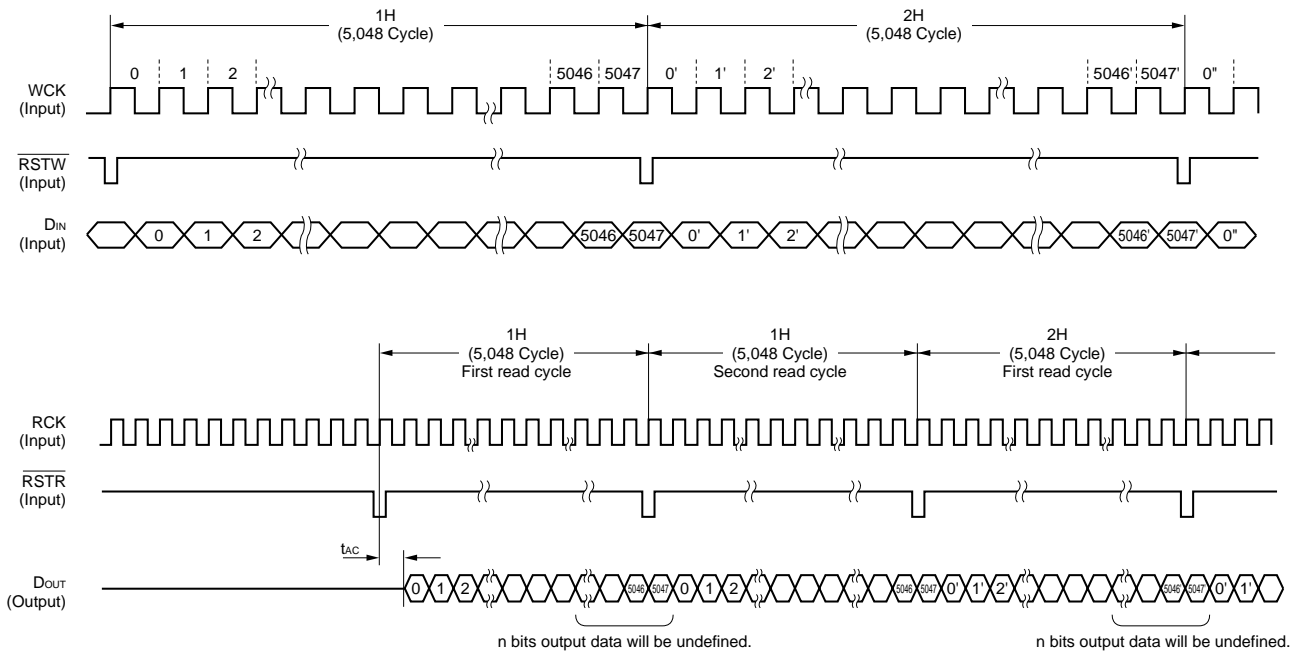

Remark \overline{RE} , \overline{WE} = "L" level

★ 5. Package Drawing

24-PIN PLASTIC SOP (11.43 mm (450))

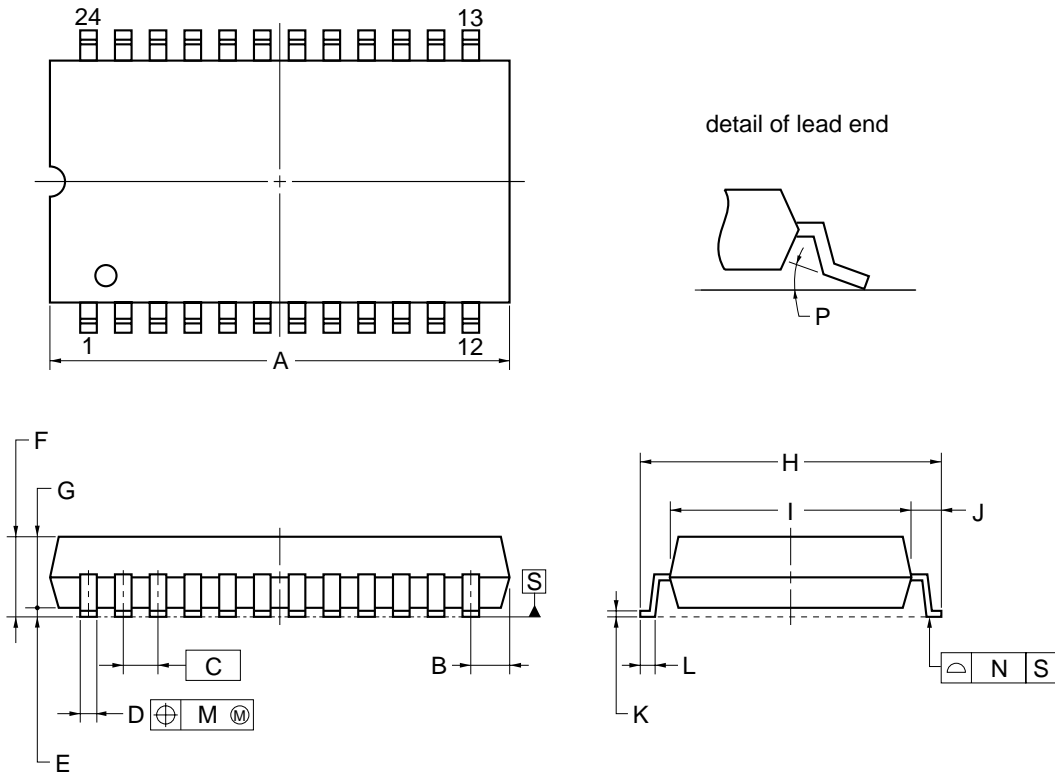

NOTE
 Each lead centerline is located within 0.12 mm of its true position (T.P.) at maximum material condition.

ITEM	MILLIMETERS
A	15.5±0.2
B	1.27 MAX.
C	1.27 (T.P.)
D	0.42±0.08
E	0.1±0.1
F	2.1±0.2
G	2.0
H	12.2±0.3
I	8.4±0.2
J	1.9±0.2
K	0.17 ^{+0.08} _{-0.07}
L	0.9±0.2
M	0.12
N	0.10
P	5°±5°

P24GM-50-450A-4

6. Recommended Soldering Conditions

Please consult with our sales offices for soldering conditions of the μPD485505.

Type of Surface Mount Device

μPD485505G: 24-pin plastic SOP (11.43 mm (450))

7. Example of Stamping

Letter E in the fifth character position in a lot number signifies version E, letter K, version K, letter P, version P, and letter L, version L.

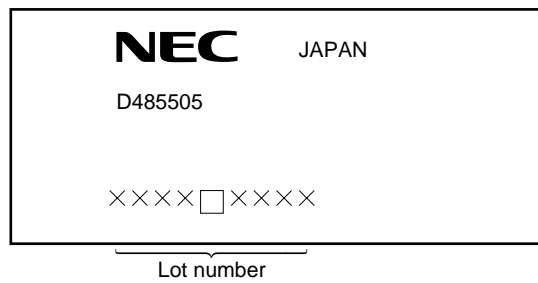

NOTES FOR CMOS DEVICES

① PRECAUTION AGAINST ESD FOR SEMICONDUCTORS

Note:

Strong electric field, when exposed to a MOS device, can cause destruction of the gate oxide and ultimately degrade the device operation. Steps must be taken to stop generation of static electricity as much as possible, and quickly dissipate it once, when it has occurred. Environmental control must be adequate. When it is dry, humidifier should be used. It is recommended to avoid using insulators that easily build static electricity. Semiconductor devices must be stored and transported in an anti-static container, static shielding bag or conductive material. All test and measurement tools including work bench and floor should be grounded. The operator should be grounded using wrist strap. Semiconductor devices must not be touched with bare hands. Similar precautions need to be taken for PW boards with semiconductor devices on it.

② HANDLING OF UNUSED INPUT PINS FOR CMOS

Note:

No connection for CMOS device inputs can be cause of malfunction. If no connection is provided to the input pins, it is possible that an internal input level may be generated due to noise, etc., hence causing malfunction. CMOS devices behave differently than Bipolar or NMOS devices. Input levels of CMOS devices must be fixed high or low by using a pull-up or pull-down circuitry. Each unused pin should be connected to V_{DD} or GND with a resistor, if it is considered to have a possibility of being an output pin. All handling related to the unused pins must be judged device by device and related specifications governing the devices.

③ STATUS BEFORE INITIALIZATION OF MOS DEVICES

Note:

Power-on does not necessarily define initial status of MOS device. Production process of MOS does not define the initial operation status of the device. Immediately after the power source is turned ON, the devices with reset function have not yet been initialized. Hence, power-on does not guarantee out-pin levels, I/O settings or contents of registers. Device is not initialized until the reset signal is received. Reset operation must be executed immediately after power-on for devices having reset function.

[MEMO]

- **The information in this document is subject to change without notice. Before using this document, please confirm that this is the latest version.**
 - No part of this document may be copied or reproduced in any form or by any means without the prior written consent of NEC Corporation. NEC Corporation assumes no responsibility for any errors which may appear in this document.
 - NEC Corporation does not assume any liability for infringement of patents, copyrights or other intellectual property rights of third parties by or arising from use of a device described herein or any other liability arising from use of such device. No license, either express, implied or otherwise, is granted under any patents, copyrights or other intellectual property rights of NEC Corporation or others.
 - Descriptions of circuits, software, and other related information in this document are provided for illustrative purposes in semiconductor product operation and application examples. The incorporation of these circuits, software, and information in the design of the customer's equipment shall be done under the full responsibility of the customer. NEC Corporation assumes no responsibility for any losses incurred by the customer or third parties arising from the use of these circuits, software, and information.
 - While NEC Corporation has been making continuous effort to enhance the reliability of its semiconductor devices, the possibility of defects cannot be eliminated entirely. To minimize risks of damage or injury to persons or property arising from a defect in an NEC semiconductor device, customers must incorporate sufficient safety measures in its design, such as redundancy, fire-containment, and anti-failure features.
 - NEC devices are classified into the following three quality grades:
"Standard", "Special", and "Specific". The Specific quality grade applies only to devices developed based on a customer designated "quality assurance program" for a specific application. The recommended applications of a device depend on its quality grade, as indicated below. Customers must check the quality grade of each device before using it in a particular application.
 - Standard: Computers, office equipment, communications equipment, test and measurement equipment, audio and visual equipment, home electronic appliances, machine tools, personal electronic equipment and industrial robots
 - Special: Transportation equipment (automobiles, trains, ships, etc.), traffic control systems, anti-disaster systems, anti-crime systems, safety equipment and medical equipment (not specifically designed for life support)
 - Specific: Aircraft, aerospace equipment, submersible repeaters, nuclear reactor control systems, life support systems or medical equipment for life support, etc.
- The quality grade of NEC devices is "Standard" unless otherwise specified in NEC's Data Sheets or Data Books. If customers intend to use NEC devices for applications other than those specified for Standard quality grade, they should contact an NEC sales representative in advance.