

# $\mu$ PD7831XA Family 16-/8-Bit, Single-Chip, High-Performance Real-Time-Control Microcomputers

**NEC**  
NEC Electronics Inc.

## Description

The  $\mu$ PD7831XA microcomputers are designed for use in process control. They perform all the usual process control functions and are particularly well-suited for driving stepper motors and dc motors in servo loops. The processors include on-chip memory, timers, input/output registers, and a powerful interrupt handling facility. The  $\mu$ PD7831XA family is constructed of high-speed CMOS circuitry and operates from a single 5 V supply.

The input frequency (maximum 12 MHz) is derived from an external crystal or an external oscillator. The internal processor clock is two-phase, and thus machine states are executed at a rate of 6 MHz. The shortest instructions require three states, making the minimum time 500 ns. The CPU contains a three-byte instruction prefetch queue, which allows a subsequent instruction to be fetched during execution of an instruction that does not reference memory.

Program memory is 8K bytes of mask-programmable ROM ( $\mu$ PD78312A only), and data memory is 256 bytes of static RAM. The  $\mu$ PD78310A is the ROMless version.

Note:  $\mu$ PD78P312A is a prototyping chip for  $\mu$ PD78312A. It has an on-chip 8K EPROM instead of a mask ROM.

## Features

- Complete single-chip microcomputer
  - 16-bit ALU
  - 8K ROM ( $\mu$ PD78312A only)
  - 256 bytes RAM
  - 1-bit and 8-bit logic
- Instruction prefetch queue
- 16-bit unsigned multiply and divide
- String instructions
- Memory expansion
  - 8085A bus-compatible
  - Total 64K address space
- Large I/O capacity: up to 40 I/O port lines
- Extensive timer/counter system
  - Two 16-bit up/down counters
  - Two 16-bit timers
  - Free-running counter with two 16-bit capture registers
  - Quadrature counter
  - Pulse-width modulated outputs
  - Timebase counter
- Four-channel 8-bit A/D converter
- Two 4-bit real-time outputs ports

- Two nonmaskable interrupts
- Eight hardware priority interrupt levels
- Macro service facility for interrupts gives the effect of eight DMA channels
- Bidirectional serial port
  - Either UART or interface mode
  - Dedicated baud-rate generator
- Watchdog timer
- Refresh output for pseudostatic RAM
- Programmable HALT and STOP modes
- One-byte call instruction
- One-chip clock generator
- CMOS silicon gate technology
- 5 V power supply

## 7831XA Family Architecture

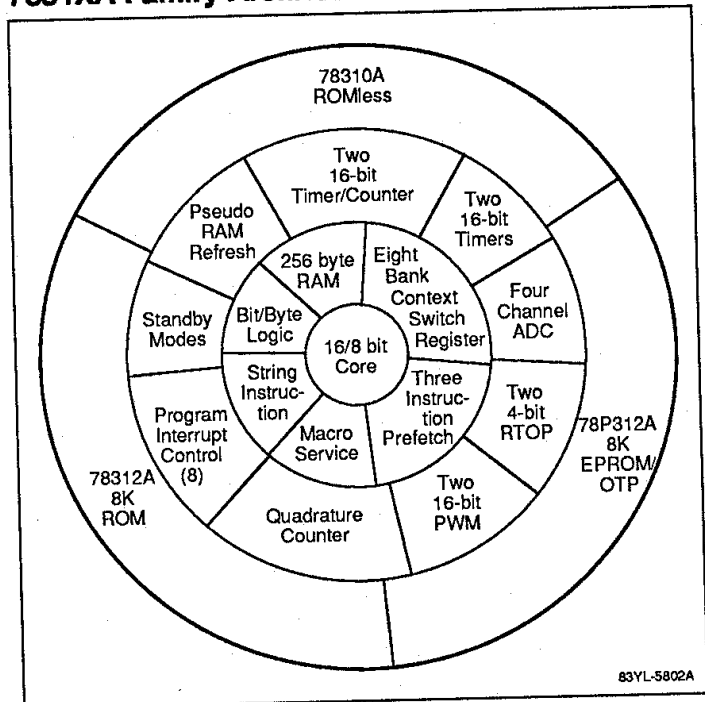

## Ordering Information

Part Number	ROM	Package	Available
$\mu$ PD78310ACW	ROMless	64-pin plastic shrink DIP	Now
$\mu$ PD78310AG-36		64-pin plastic QUIP	
$\mu$ PD78310AG-1B		64-pin plastic miniflat	
$\mu$ PD78310AL		68-pin PLCC	
$\mu$ PD78312ACW	Mask ROM	64-pin plastic shrink DIP	Now
$\mu$ PD78312AG-36		64-pin plastic QUIP	
$\mu$ PD78312AG-1B		64-pin plastic miniflat	
$\mu$ PD78312AL		68-pin PLCC	

## Ordering Information (cont)

Part Number	ROM	Package	Available
μPD78P312ADW	UV EPROM	64-pin shrink cerdip	Now
μPD78P312AR		64-pin ceramic QUIP	
μPD78P312ACW	OTP ROM	64-pin plastic shrink DIP	Now
μPD78P312AG-36		64-pin plastic QUIP	
μPD78P312AL		68-pin PLCC	

**Note:** A 74-pin miniflat package that can be reflow soldered will be available.

## Block Diagram

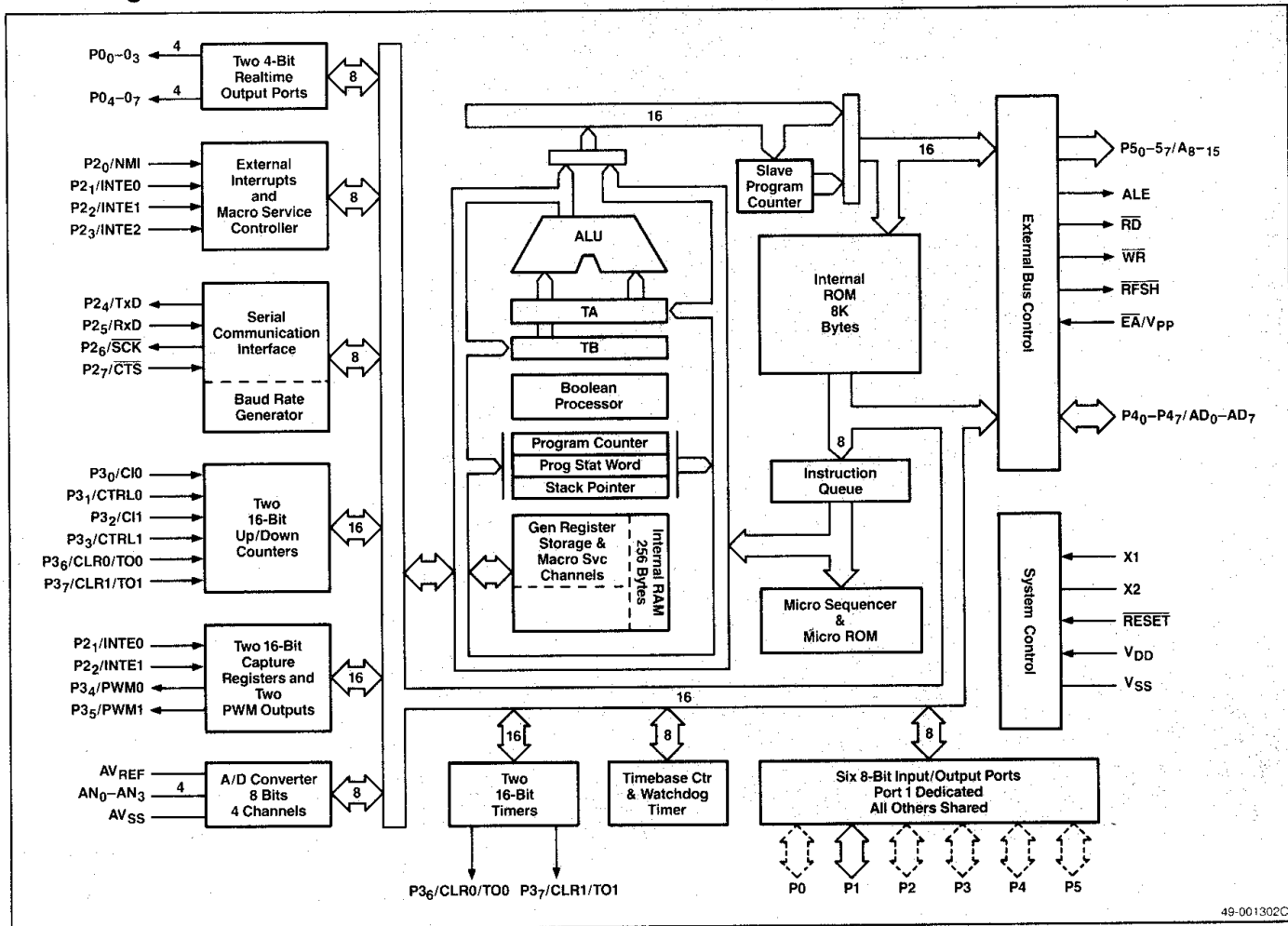

4

49-001302C