

GaAs MMIC DBS 4 × 2 IF Switch

DESCRIPTION

The μ PG183GR is intended for use in Direct Broadcast Satellite (DBS) applications within the Low Noise Block (LNB) down-converter for systems where at least two LNB outputs are required.

It offers 4 intermediate frequency amplifier channels that can independently select 1 of 4 IF inputs. It is housed in a very small 16-pin plastic HTSSOP package available on tape-and-reel and easy to install and contributes to miniaturizing the systems.

FEATURES

- 4 independent IF channels
- Integral switching to channel input to either channel output
- Frequency range : 950 to 2 150 MHz
- Insertion loss per channel : 7.0 dB TYP. ($Z_0 = 50 \Omega$)
- Channel to channel isolation : 26.5 dB TYP.
- Small 16-pin HTSSOP Package

ORDERING INFORMATION (PLAN)

Part Number	Package	Supplying Form
μ PG183GR-E1	16-pin Plastic HTSSOP	Carrier tape width 12 mm. Qty 3 kpcs/reel.

Remark To order evaluation samples, please contact your local NEC sales office. (Part number for sample order: μ PG183GR)

Caution The IC must be handled with care to prevent static discharge because its circuit composed of GaAs MES-FET.

The information in this document is subject to change without notice. Before using this document, please confirm that this is the latest version.
Not all devices/types available in every country. Please check with local NEC representative for availability and additional information.

ABSOLUTE MAXIMUM RATINGS (T_A = +25°C)

Parameter	Symbol	Ratings	Unit
Control Voltage 1, 2, 3, 4, 5, 6, 7, 8	V _{CONT1, 2, 3, 4, 5, 6, 7, 8}	-1.0 to +6.0	V
Input Power	P _{in}	+10	dBm
Total Power Dissipation	P _{tot}	2 ^{Note}	W
Operating Ambient Temperature	T _A	-40 to +85	°C
Storage Temperature	T _{stg}	-65 to +150	°C

Note Mounted on 50 × 50 × 1.6 mm double copper clad epoxy glass PWB, T_A = +85°C

PIN CONNECTION AND INTERNAL BLOCK DIAGRAM

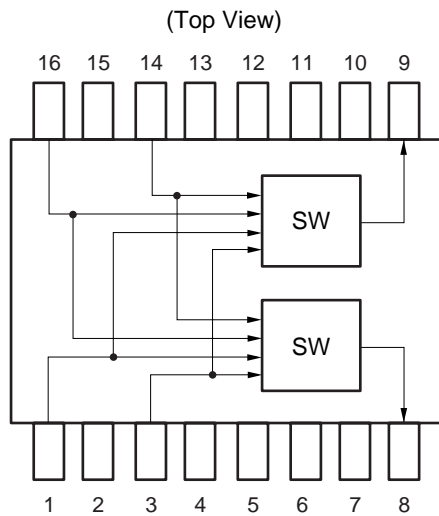

Pin No.	Connection	Pin No.	Connection
1	IN-C	9	OUT1
2	GND	10	V _{CONT4}
3	IN-D	11	V _{CONT3}
4	V _{CONT5}	12	V _{CONT2}
5	V _{CONT6}	13	V _{CONT1}
6	V _{CONT7}	14	IN-A
7	V _{CONT8}	15	GND
8	OUT2	16	IN-B

RECOMMENDED OPERATING CONDITIONS (T_A = +25°C)

Parameter	Symbol	MIN.	TYP.	MAX.	Unit
Control Voltage (High)	V _{CONT(H)}	+4.5	+5.0	+5.5	V
Control Voltage (Low)	V _{CONT(L)}	-0.5	0	+0.5	V

ELECTRICAL CHARACTERISTICS (T_A = +25°C, unless otherwise specified: V_{CONT1} to V_{CONT8} = 0/ +5 V, P_{in} = 0 dBm, Z_o = 50 Ω, Each Port)

Parameter	Symbol	Test Conditions	MIN.	TYP.	MAX.	Unit
Insertion Loss 1	L _{INS1}	f = 0.95 to 1.5 GHz	-	7.0	9.0	dB
Insertion Loss 2	L _{INS2}	f = 1.5 to 2.15 GHz	-	8.0	10.0	dB
Insertion Loss Flatness	ΔL _{INS}	L _{INS} (0.95 GHz) – L _{INS} (2.15 GHz)	-	1.5	3.0	dB
Channel Isolation 1	ISL1	f = 0.95 to 1.5 GHz	24	26.5	-	dB
Channel Isolation 2	ISL2	f = 1.5 to 2.15 GHz	22	23.5	-	dB
Output Return Loss	RL _{out}	f = 0.95 to 2.15 GHz	10	14	-	dB
Control Current ^{Note}	I _{CONT}	V _{CONT} = +5 V/0 V, RF OFF	-	-	0.5	mA

Note Per 1 control pin

EVALUATION CIRCUIT (Preliminary)

V_{CONT1} to $V_{CONT8} = 0/ +5 V$, $P_{in} = 0 \text{ dBm}$, $Z_o = 50 \Omega$, DC Blocking Capacitor = 51 pF

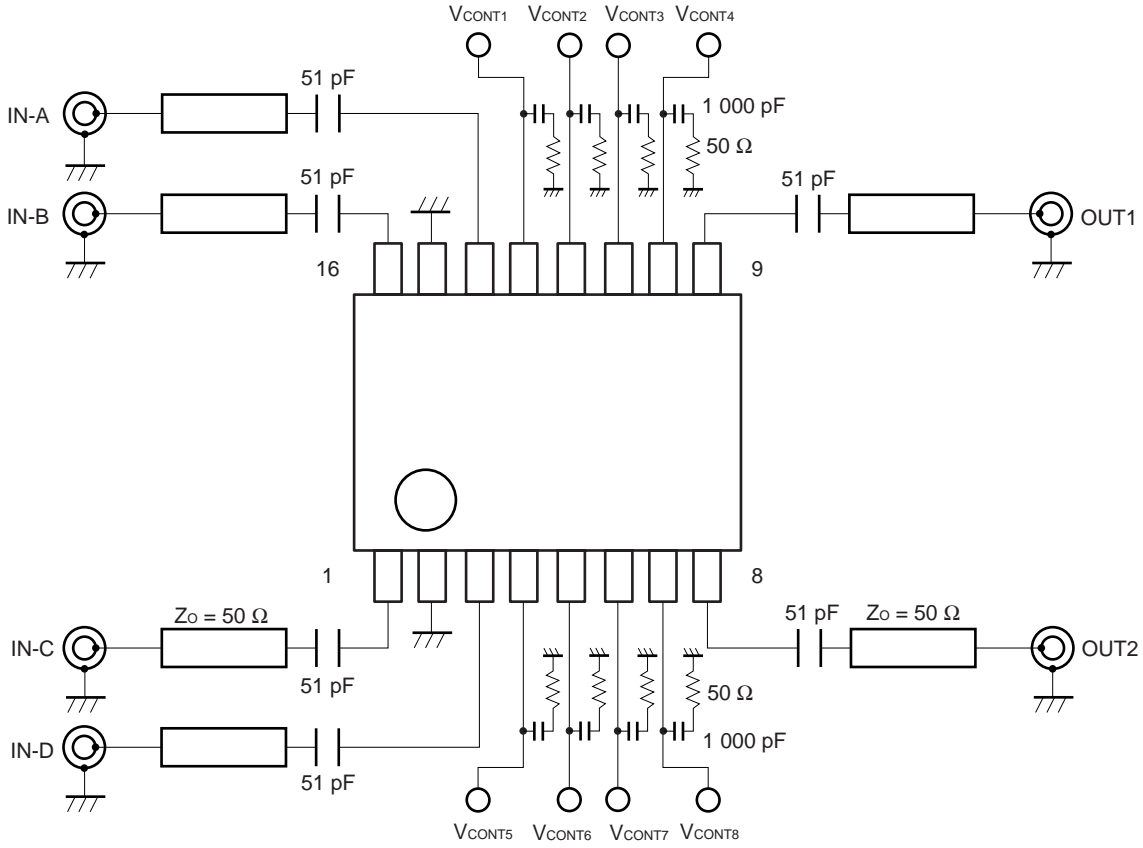

CHANNEL SELECT TRUTH TABLE

On Channel		Control Pin							
OUT1	OUT2	V_{CONT1}	V_{CONT2}	V_{CONT3}	V_{CONT4}	V_{CONT5}	V_{CONT6}	V_{CONT7}	V_{CONT8}
IN-A	–	High	Low	High	Low	–	–	–	–
IN-B	–	High	Low	Low	High	–	–	–	–
IN-C	–	Low	High	High	Low	–	–	–	–
IN-D	–	Low	High	Low	High	–	–	–	–
–	IN-A	–	–	–	–	High	Low	High	Low
–	IN-B	–	–	–	–	High	Low	Low	High
–	IN-C	–	–	–	–	Low	High	High	Low
–	IN-D	–	–	–	–	Low	High	Low	High

TYPICAL CHARACTERISTICS (T_A = +25°C)

INSERTION LOSS vs. FREQUENCY

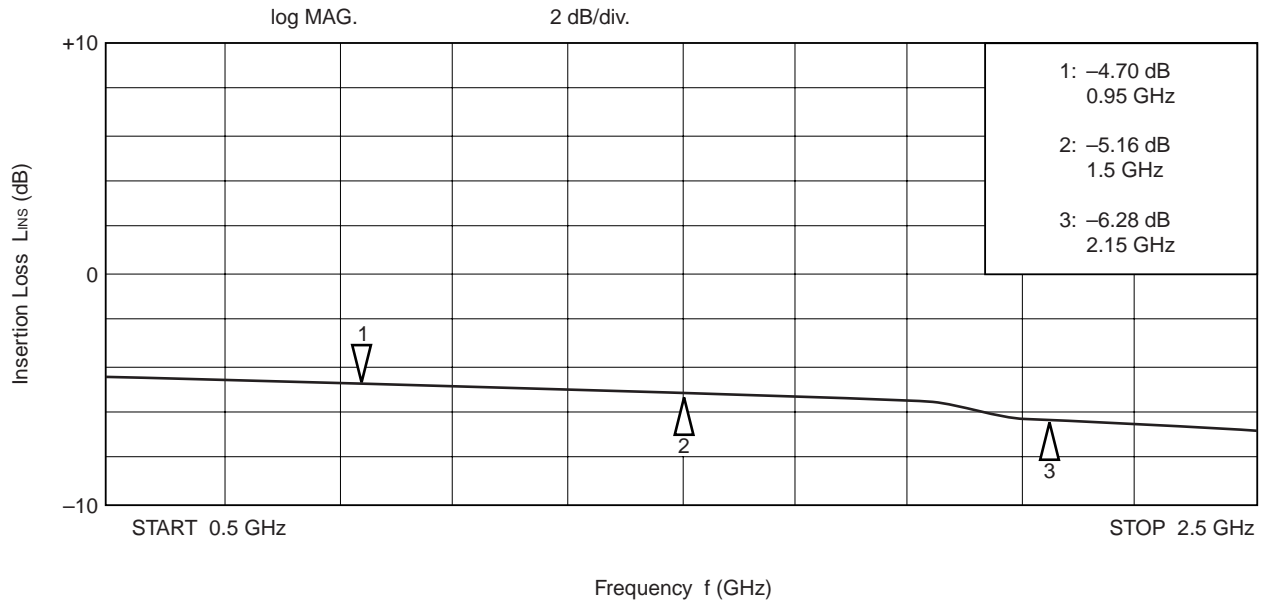

ISOLATION vs. FREQUENCY

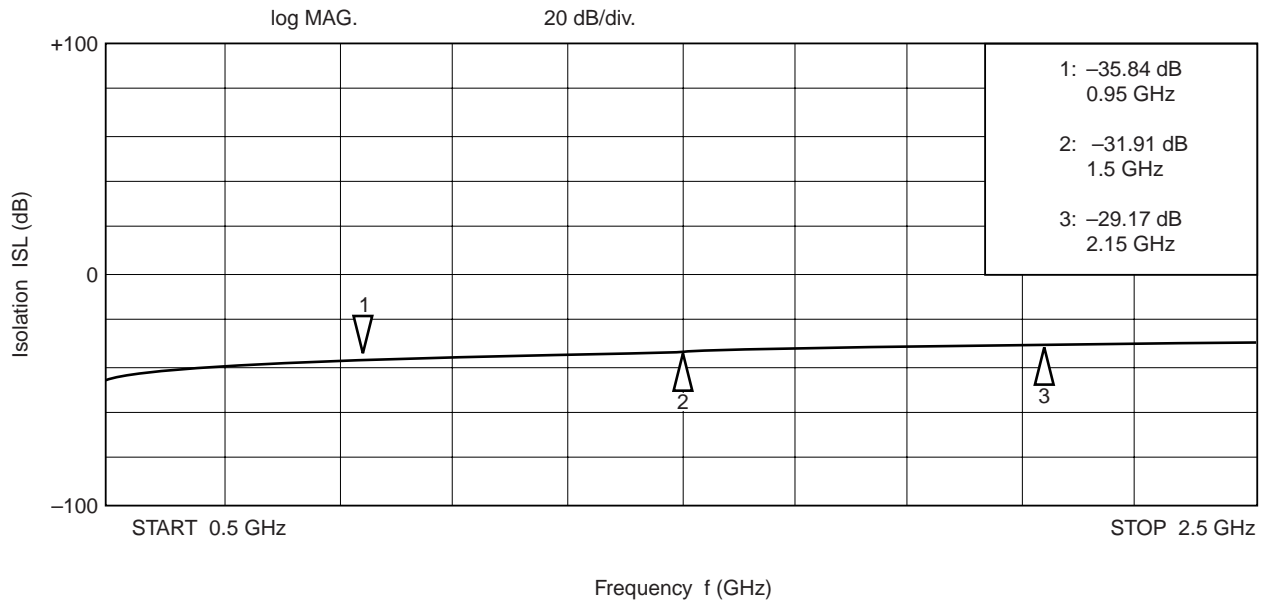

INPUT RETURN LOSS vs. FREQUENCY

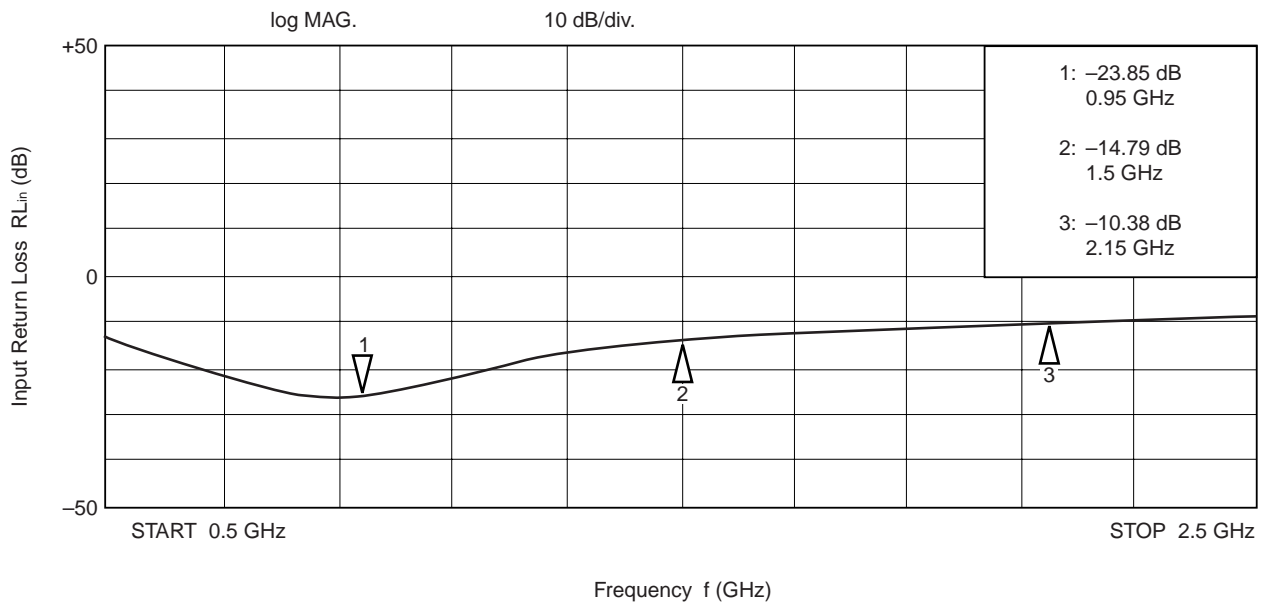

OUTPUT RETURN LOSS vs. FREQUENCY

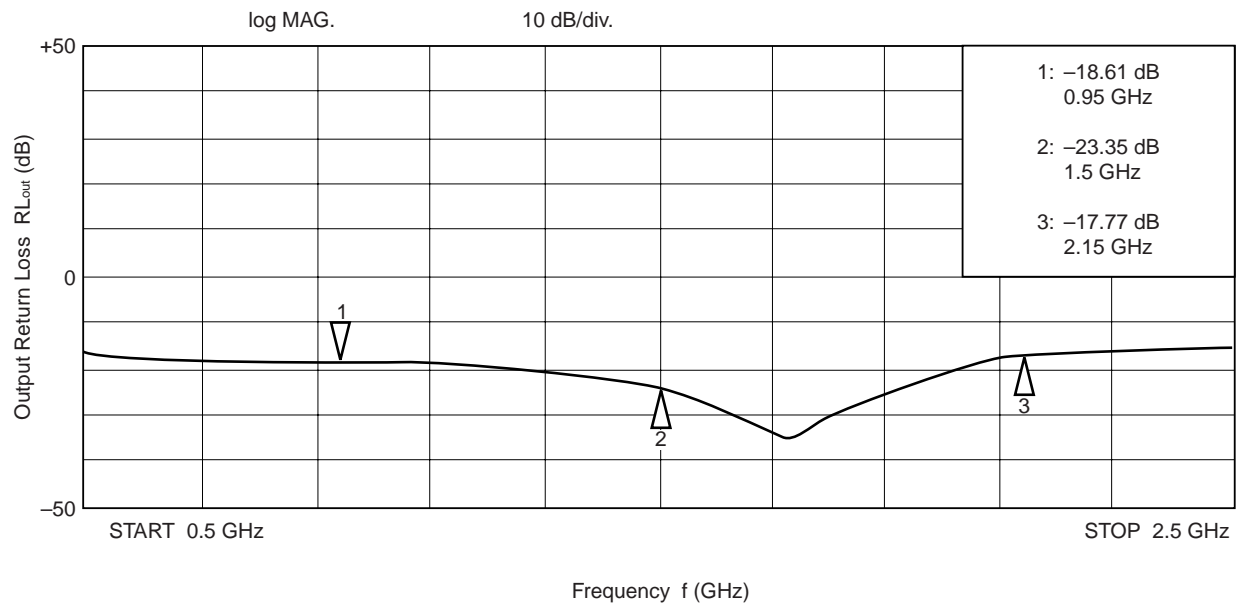

PACKAGE DIMENSIONS
16-PIN HTSSOP (Unit: mm)

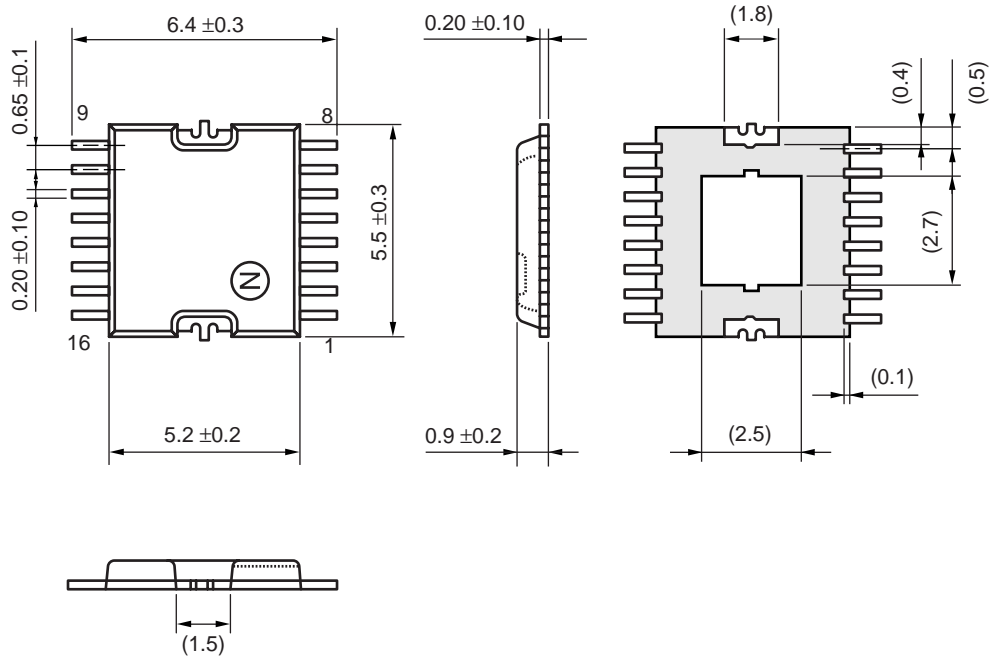

RECOMMENDED SOLDERING CONDITIONS

This product should be soldered under the following recommended conditions. For soldering methods and conditions other than those recommended below, contact your NEC sales representative.

Soldering Method	Soldering Conditions	Recommended Condition Symbol
Infrared Reflow	Package peak temperature: 240°C or below Time: 30 seconds or less (at 210°C) Count: 3, Exposure limit: None ^{Note}	IR40-00-3
VPS	Package peak temperature: 215°C or below Time: 40 seconds or less (at 200°C) Count: 3, Exposure limit: None ^{Note}	VP15-00-3
Wave Soldering	Soldering bath temperature: 260°C or below Time: 10 seconds or less Count: 1, Exposure limit: None ^{Note}	WS60-00-1
Partial Heating	Pin temperature: 300°C Time: 3 seconds or less (per side of device) Exposure limit: None ^{Note}	—

Note After opening the dry pack, keep it in a place below 25°C and 65% RH for the allowable storage period.

Caution Do not use different soldering methods together (except for partial heating).

For details of recommended soldering conditions for surface mounting, refer to information document SEMICONDUCTOR DEVICE MOUNTING TECHNOLOGY MANUAL (C10535E).

[MEMO]

[MEMO]

[MEMO]

CAUTION

The great care must be taken in dealing with the devices in this guide.

The reason is that the material of the devices is GaAs (Gallium Arsenide), which is designated as harmful substance according to the law concerned.

Keep the law concerned and so on, especially in case of removal.

- **The information in this document is current as of October, 2000. The information is subject to change without notice. For actual design-in, refer to the latest publications of NEC's data sheets or data books, etc., for the most up-to-date specifications of NEC semiconductor products. Not all products and/or types are available in every country. Please check with an NEC sales representative for availability and additional information.**
- No part of this document may be copied or reproduced in any form or by any means without prior written consent of NEC. NEC assumes no responsibility for any errors that may appear in this document.
- NEC does not assume any liability for infringement of patents, copyrights or other intellectual property rights of third parties by or arising from the use of NEC semiconductor products listed in this document or any other liability arising from the use of such products. No license, express, implied or otherwise, is granted under any patents, copyrights or other intellectual property rights of NEC or others.
- Descriptions of circuits, software and other related information in this document are provided for illustrative purposes in semiconductor product operation and application examples. The incorporation of these circuits, software and information in the design of customer's equipment shall be done under the full responsibility of customer. NEC assumes no responsibility for any losses incurred by customers or third parties arising from the use of these circuits, software and information.
- While NEC endeavours to enhance the quality, reliability and safety of NEC semiconductor products, customers agree and acknowledge that the possibility of defects thereof cannot be eliminated entirely. To minimize risks of damage to property or injury (including death) to persons arising from defects in NEC semiconductor products, customers must incorporate sufficient safety measures in their design, such as redundancy, fire-containment, and anti-failure features.
- NEC semiconductor products are classified into the following three quality grades:
"Standard", "Special" and "Specific". The "Specific" quality grade applies only to semiconductor products developed based on a customer-designated "quality assurance program" for a specific application. The recommended applications of a semiconductor product depend on its quality grade, as indicated below. Customers must check the quality grade of each semiconductor product before using it in a particular application.
"Standard": Computers, office equipment, communications equipment, test and measurement equipment, audio and visual equipment, home electronic appliances, machine tools, personal electronic equipment and industrial robots
"Special": Transportation equipment (automobiles, trains, ships, etc.), traffic control systems, anti-disaster systems, anti-crime systems, safety equipment and medical equipment (not specifically designed for life support)
"Specific": Aircraft, aerospace equipment, submersible repeaters, nuclear reactor control systems, life support systems and medical equipment for life support, etc.

The quality grade of NEC semiconductor products is "Standard" unless otherwise expressly specified in NEC's data sheets or data books, etc. If customers wish to use NEC semiconductor products in applications not intended by NEC, they must contact an NEC sales representative in advance to determine NEC's willingness to support a given application.

(Note)

- (1) "NEC" as used in this statement means NEC Corporation and also includes its majority-owned subsidiaries.
- (2) "NEC semiconductor products" means any semiconductor product developed or manufactured by or for NEC (as defined above).