

2N3741A

APPLICATIONS:

- Drivers
- Switches
- Medium-Power Amplifiers

FEATURES:

- Low Saturation Voltage: 0.6 V_{CE(sat)} @ I_C = 1.0 Amp
- High Gain Characteristics: hFE @ I_C = 250 mA: 30-100
- Excellent Safe Area Limits
- Low Collector Cutoff Current: 100 nA (Max) 2N3741A

**Medium Power
 PNP Transistors**

DESCRIPTION:

These power transistors are produced by PPC's DOUBLE DIFFUSED PLANAR process. This technology produces high voltage devices with excellent switching speeds, frequency response, gain linearity, saturation voltages, high current gain, and safe operating areas. They are intended for use in Commercial, Industrial, and Military power switching, amplifier, and regulator applications.

Ultrasonically bonded leads and controlled die mount techniques are utilized to further increase the SOA capability and inherent reliability of these devices. The temperature range to 200°C permits reliable operation in high ambients, and the hermetically sealed package insures maximum reliability and long life.

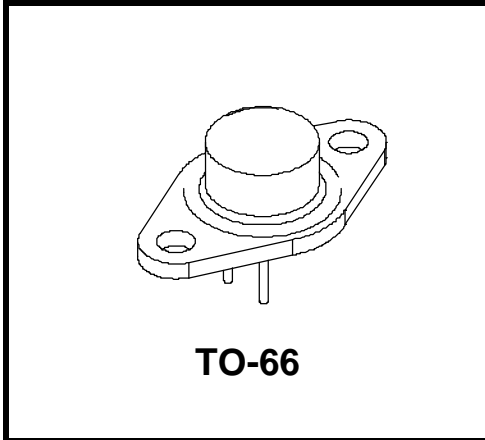

ABSOLUTE MAXIMUM RATINGS:

SYMBOL	CHARACTERISTIC	VALUE	UNITS
V _{CEO} *	Collector-Emitter Voltage	80	Vdc
V _{EB} *	Emitter-Base Voltage	7.0	Vdc
V _{CB} *	Collector-Base Voltage	80	Vdc
I _C *	Peak Collector Current	10	Adc
I _C	Continuous Collector Current	4.0	Adc
I _B *	Base Current	2.0	Adc
T _{STG} *	Storage Temperature	-65 to 200	°C
T _J *	Operating Junction Temperature	-65 to 200	°C
P _D *	Total Device Dissipation	25	Watts
	T _C = 25°C		
	Derate above 25°C	0.143	W/°C
θ _{JC}	Thermal Impedance	7	°C/W

* Indicates JEDEC registered data.

2N3741A

**ELECTRICAL CHARACTERISTICS:
 (25° Case Temperature Unless Otherwise Noted)**

SYMBOL	CHARACTERISTIC	TEST CONDITIONS	VALUE		Units
			Min.	Max.	
$V_{CE(sus)}^*$	Collector-Emitter Sustaining Voltage	$I_C = 100 \text{ mAdc}, I_B = 0$ (Note 1)	80	----	Vdc
I_{EB0}^*	Emitter Base Cutoff Current	$V_{EB} = 7.0 \text{ Vdc}$	----	100	nAdc
I_{CEX}^*	Collector Cutoff Current	$V_{CE} = 80 \text{ Vdc}, V_{BE(off)} = 1.5 \text{ Vdc}$ $V_{CE} = 60 \text{ Vdc}, V_{BE(off)} = 1.5 \text{ Vdc}, T_C = 150^\circ\text{C}$	----	100 0.5	nAdc mAdc
I_{CE0}^*	Collector-Emitter Cutoff Current	$V_{CE} = 60 \text{ Vdc}, I_B = 0$	----	1.0	μAdc
I_{CB0}^*	Collector Base Cutoff Current	$V_{CB} = 80 \text{ Vdc}, I_E = 0$	----	100	nAdc
h_{FE}^*	DC Current Gain (Note 1)	$I_C = 100 \text{ mAdc}, V_{CE} = 1.0 \text{ Vdc}$ $I_C = 250 \text{ mAdc}, V_{CE} = 1.0 \text{ Vdc}$ $I_C = 500 \text{ mAdc}, V_{CE} = 1.0 \text{ Vdc}$ $I_C = 1.0 \text{ Adc}, V_{CE} = 1.0 \text{ Vdc}$	40 30 20 10	---- 100 ---- ----	---- ---- ---- ----
$V_{CE(sat)}^*$	Collector-Emitter Saturation Voltage (Note 1)	$I_C = 1.0 \text{ Adc}, I_B = 125 \text{ mAdc}$	----	0.6	Vdc
V_{BE}^*	Base-Emitter Voltage (Note 1)	$I_C = 250 \text{ mAdc}, V_{CE} = 1.0 \text{ Vdc}$	----	1.0	Vdc
f_T^*	Current Gain Bandwidth Product	$I_C = 100 \text{ mAdc}, V_{CE} = 10 \text{ Vdc}, f = 1.0 \text{ MHz}$	3.0	----	MHz
h_{fe}^*	Small-Signal Current Gain	$I_C = 50 \text{ mAdc}, V_{CE} = 10 \text{ Vdc}, f = 1.0 \text{ kHz}$	25	----	----
C_{ob}^*	Common Base Output Capacitance	$V_{CB} = 10 \text{ Vdc}, I_C = 0, f = 100 \text{ kHz}$	----	100	pF

Note 1: Pulse Test: $PW \leq 300\mu\text{s}$, Duty Cycle $\leq 2.0\%$

* Indicates JEDEC registered data.

2N3741A

PACKAGE MECHANICAL DATA:

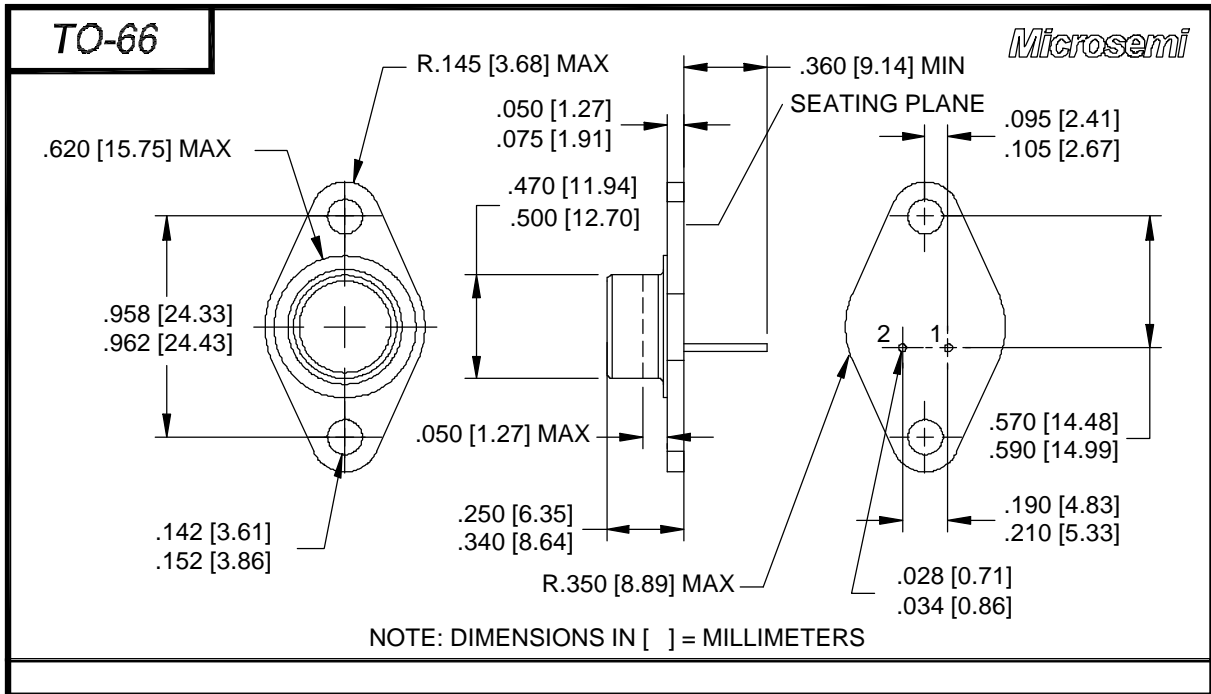



LittleDiode supplies new, hard to find or obsolete electronic components and semiconductors all over the world.

With over two million different components listed you are sure to find the part you need.

Feel free to visit us today at our online store:

LittleDiode.com

Looking forward to providing you with the best possible service.