

**2N4199
thru
2N4204**

Designer's Data Sheet
Silicon Controlled Rectifiers
Reverse Blocking Triode Thyristors

... fast switching, high-voltage Thyristors especially designed for pulse modulator applications in radar and other similar equipment.

- Guaranteed Limits on All Critical Parameters
- High-Voltage: $V_{DRM} = 300$ to 800 Volts
- Maximum Turn-On Times Specified — 300 to 400 ns
- Repetitive Pulse Current to 100 Amperes
- Stable Switching Characteristics Over an Operating Temperature Range From
-65 to +105°C
- Pulse Repetition Rates as High as 20,000 pps
- JAN Versions Available

SCRs
100 AMPERE PULSE
300 thru 800 VOLTS

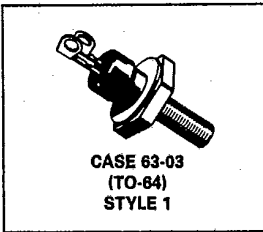

MAXIMUM RATINGS

Rating	Symbol	Value	Unit
Peak Reverse Blocking Voltage, Note 1 ($T_J = 105^\circ\text{C}$)	V_{RRM}	50	Volts
*Peak Forward Blocking Voltage, Note 1 ($T_C = 105^\circ\text{C}$)	V_{DRM}	300 400 500 600 700 800	Volts
Repetitive Peak On-State Current ($PW = 3 \mu\text{s}$, Duty Cycle = 0.6%, $T_C = 85^\circ\text{C}$)	I_{TRM}	100	Amps
Continuous On-State Current ($T_C = 65^\circ\text{C}$)	I_T	5	Amps
Current Application Rate, Note 2	di/dt	5000	A/ μs
Peak Forward Gate Power	P_{GFM}	20	Watts
Average Forward Gate Power	$P_{GF(AV)}$	1	Watt
Peak Forward Gate Current	I_{GFM}	5	Amps
Peak Gate Voltage — Forward Reverse, Note 3	V_{GFM} V_{GRM}	10 10	Volts
Operating Junction Temperature Range Blocking State Conducting State	T_J	-65 to +105 -65 to +200	$^\circ\text{C}$
Storage Temperature Range	T_{stg}	-65 to +200	$^\circ\text{C}$
Stud Torque	—	15	in. lb.

3

*Indicates JEDEC Registered Data.

Notes: 1. Characterized for unilateral applications where reverse blocking capability is not important. Higher voltage units available upon request.
 V_{DRM} and V_{RRM} may be applied as a continuous dc voltage for zero or negative gate voltage but positive gate voltage must not be applied concurrently with a negative potential on the anode. When checking blocking capability, do not permit the applied voltage to exceed the rated voltage.

2. Minimum Gate Trigger Pulse: $I_G = 200 \text{ mA}$, $PW = 1 \mu\text{s}$, $t_r = 20 \text{ ns}$.
3. Do not reverse bias gate during forward conduction if anode current exceeds 10 amperes.

Designers Data for "Worst Case" Conditions — The Designers Data Sheets permit the design of most circuits entirely from the information presented. Limit curves — representing boundaries on device characteristics — are given to facilitate "worst case" design.

T-25-15

THERMAL CHARACTERISTICS

Characteristic	Symbol	Max	Unit
*Thermal Resistance, Junction to Case	$R_{\theta JC}$	3	$^{\circ}C/W$

ELECTRICAL CHARACTERISTICS ($T_C = 25^{\circ}C$ unless otherwise noted.)

Characteristic	Fig. No.	Symbol	Min	Max	Unit
*Peak Forward or Reverse Blocking Current (Rated V_{DRM} or V_{RRM} , gate open) $T_C = 105^{\circ}C$	17	I_{DRM}, I_{RRM}	—	2	mA
Gate Trigger Current (Continuous dc) (Anode Voltage = 7 Vdc, $R_L = 100$ ohms, $T_C = 25^{\circ}C$) *(Anode Voltage = 7 Vdc, $R_L = 100$ ohms, $T_C = -65^{\circ}C$)	14	I_{GT}	—	50 100	mA
Gate Trigger Voltage (Continuous dc) *(Anode Voltage = rated V_{DRM} , $R_L = 100$ ohms, $T_C = 105^{\circ}C$) (Anode Voltage = 7 Vdc, $R_L = 100$ ohms, $T_C = 25^{\circ}C$) *(Anode Voltage = 7 Vdc, $R_L = 100$ ohms, $T_C = -65^{\circ}C$)	12	V_{GT}	0.2 — —	— 1.5 2	Volts
*Holding Current (Anode Voltage = 7 Vdc, gate open, $T_C = 105^{\circ}C$)	18	I_H	3	—	mA
*Forward "On" Voltage ($I_{TM} = 5$ Adc, PW = 1 ms max, Duty cycle $\leq 1\%$)	8	V_{TM}	2.6	—	Volts
*Dynamic Forward "On" Voltage (0.5 μs after 50% decay point on dynamic forward voltage waveform) Forward Current: 30 A pulse Gate Pulse: at 200 mA, PW = 1 μs , $t_r = 20$ ns	7	V_{TM}	—	25	Volts
*Turn-On Time $I_{TM} = 30$ A Delay Time Rise Time	1, 9 1, 11	t_d t_r	— — — — —	200 200 150 130 100	ns
*Pulse Turn-Off Time Test Conditions: PFN discharge; Forward Current = 30 A pulse; Reverse Current = 5 A, $T_C = 85^{\circ}C$, $dv/dt = 250$ V/ μs to Rated V_{DRM} ; Reverse anode voltage during turn-off interval = 0 V; Reverse gate bias during turn-off interval = 6 V.	2, 13	t_q	—	20	μs
*Forward Voltage Application Rate (Linear Rise of Voltage) ($T_C = 105^{\circ}C$, gate open, $V_D =$ Rated V_{DRM})	16	dv/dt	250	—	V/ μs

*JEDEC Registered Data.

3

T-25-15

TEST CIRCUITS

FIGURE 1 - TURN-ON TIME

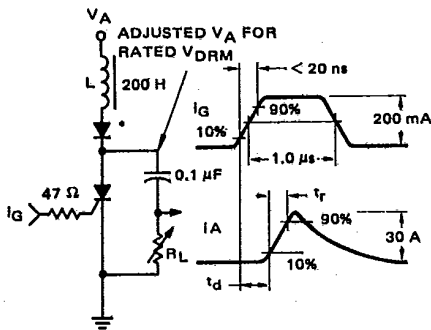

*Two 1N4937 fast-recovery diodes in series each shunted by a 180 kΩ resistor.

FIGURE 2 - TURN-OFF TIME

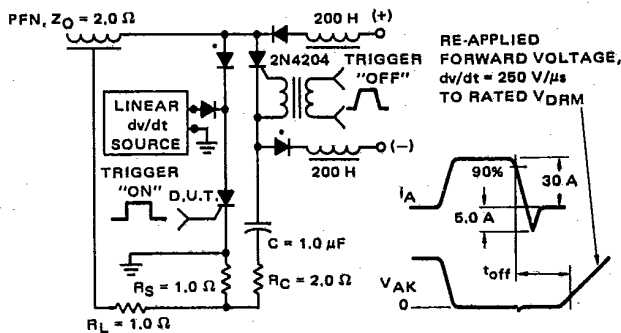
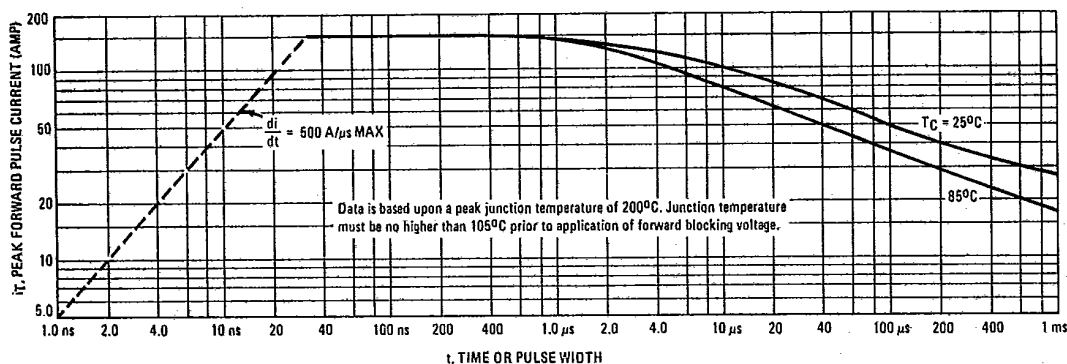

FIGURE 3 - MAXIMUM ALLOWABLE FORWARD PULSE CURRENT



3

FIGURE 4 - DERATING USING NO SWITCHING LOSSES

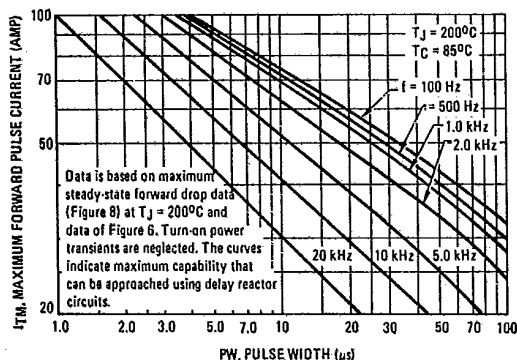
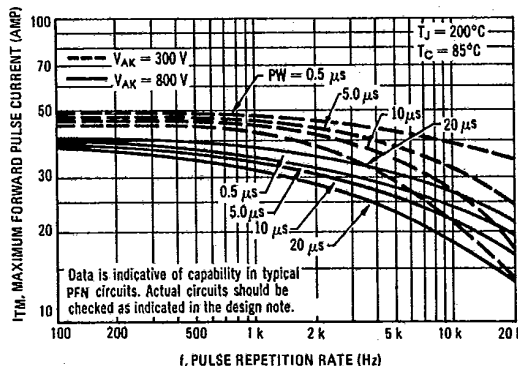
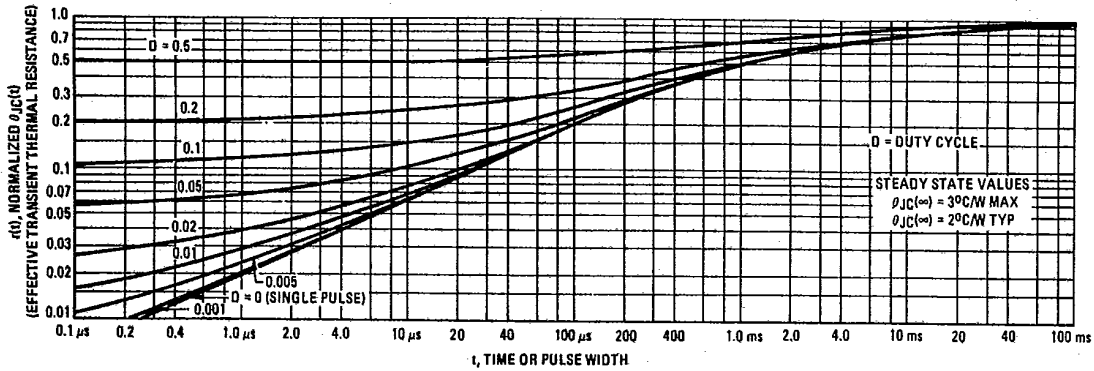

FIGURE 5 - DERATING USING TYPICAL SWITCHING LOSSES



T-25-15

FIGURE 6 - NORMALIZED EFFECTIVE TRANSIENT THERMAL RESISTANCE



FORWARD "ON" VOLTAGE DATA

FIGURE 7 - TYPICAL DYNAMIC FORWARD "ON" VOLTAGE

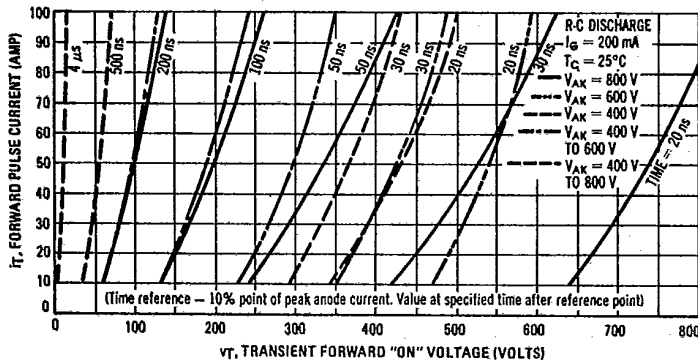
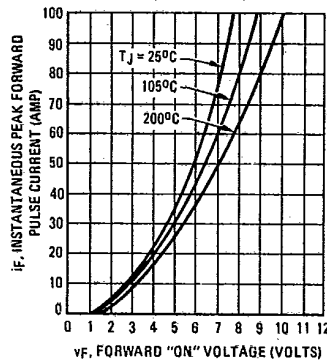

FIGURE 8 - MAXIMUM STEADY-STATE



3

DESIGN NOTE CONTINUED

$$\Delta T(t_4) = \{ 1000 [0.0205 + (1 - 5.25 \cdot 10^{-3}) 0.27 + 5.25 \cdot 10^{-3} - 0.27] + 700 [(1 - 7.75 \cdot 10^{-3}) 0.27 + 7.75 \cdot 10^{-3} - 0.27] \} 3 = 93.51^{\circ}\text{C}$$

$$\Delta T(t_5) = \{ 1000 [0.032 + (1 - 5.25 \cdot 10^{-3}) 0.27 + 5.25 \cdot 10^{-3} - 0.27 - 0.0205] + 700 [0.025 + (1 - 7.75 \cdot 10^{-3}) 0.27 + 7.75 \cdot 10^{-3} - 0.27] \} 3 = 105.6^{\circ}\text{C}$$

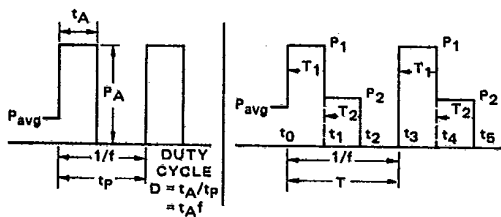

FIGURE A - SIMPLE MODEL

FIGURE B - MORE ACCURATE MODEL

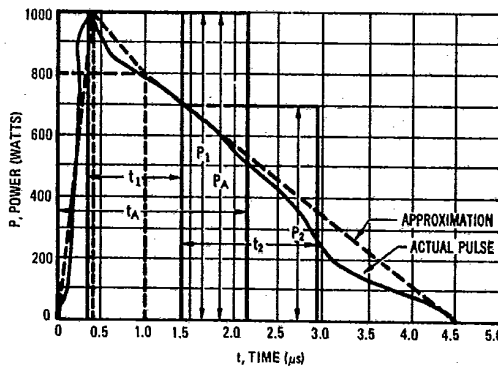
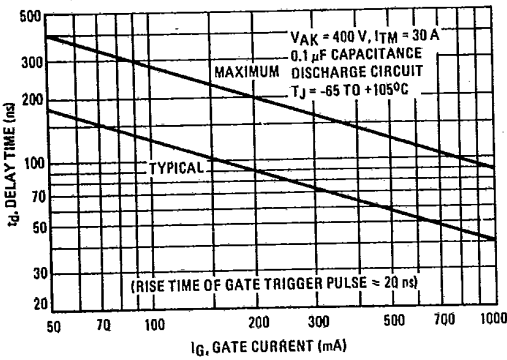

FIGURE C - AN ACTUAL TRANSIENT POWER PULSE

T-25-15

SWITCHING CHARACTERISTICS

FIGURE 9 - DELAY TIME



TRIGGERING CHARACTERISTICS

FIGURE 10 - TYPICAL PULSE TRIGGER CHARGE/CURRENT

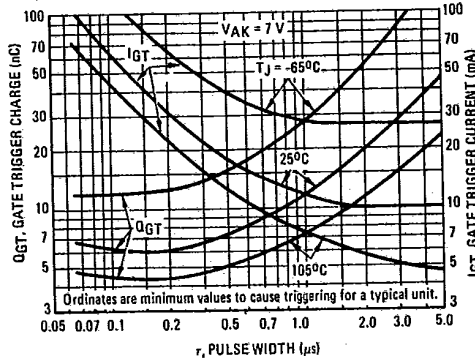

FIGURE 11 - CURRENT RISE TIME

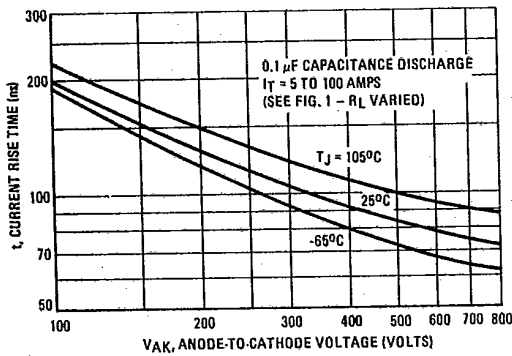
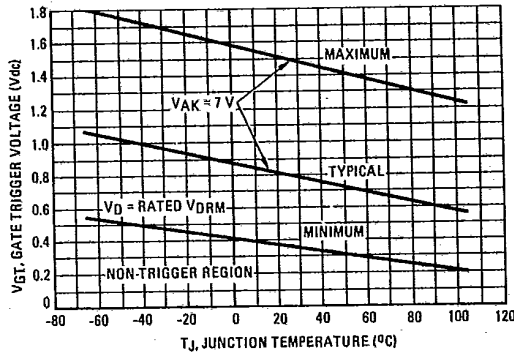

FIGURE 12 - DC GATE TRIGGER VOLTAGE



3

FIGURE 13 - TYPICAL TURN-OFF TIME

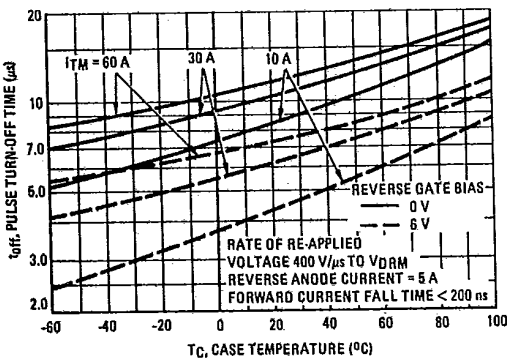
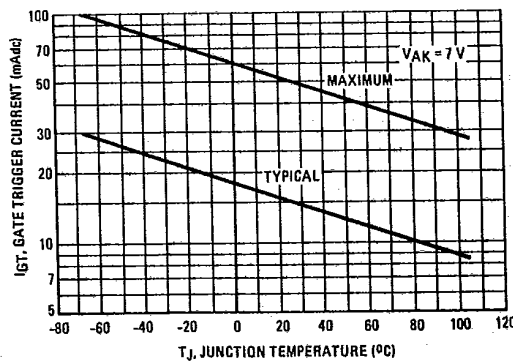
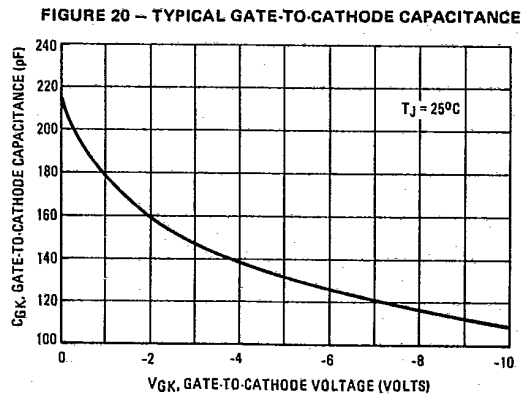
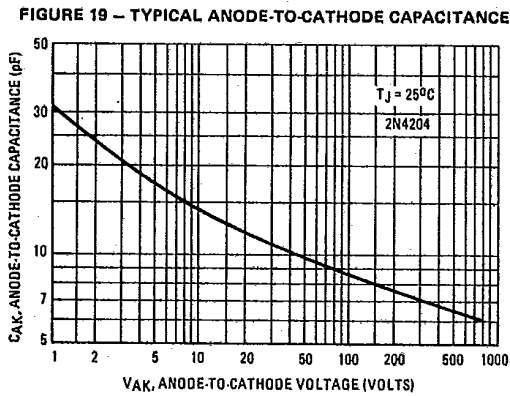
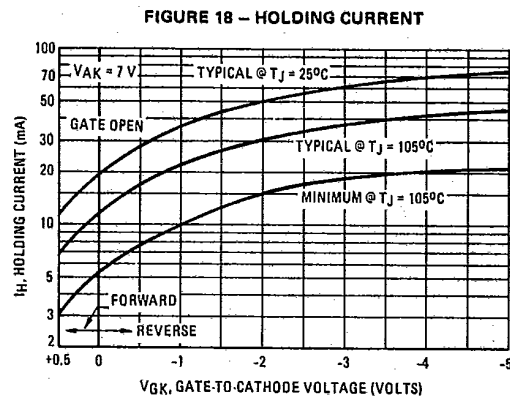
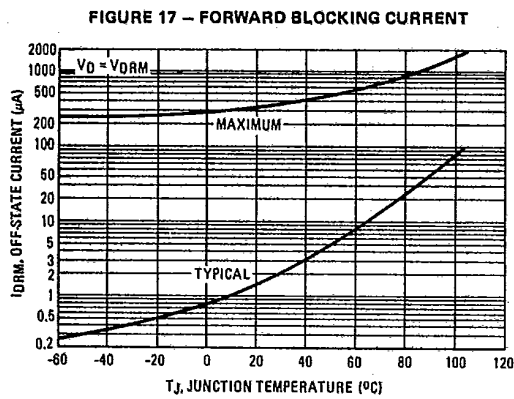
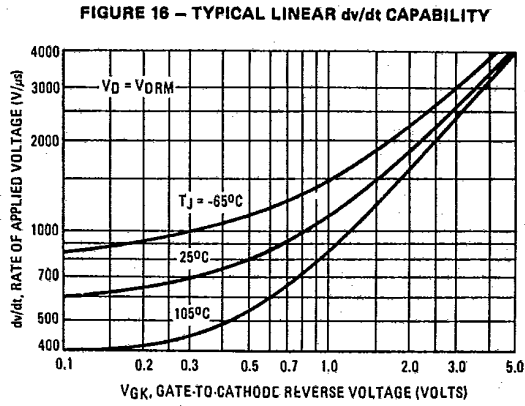
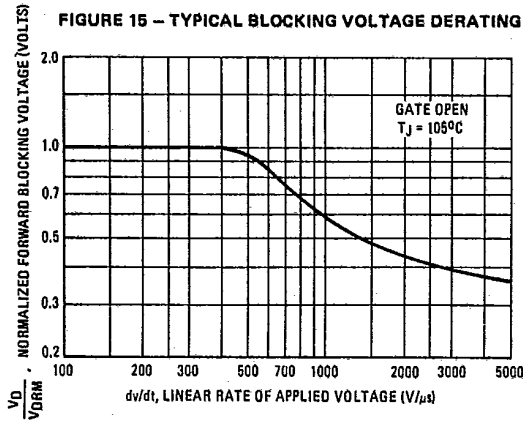

FIGURE 14 - DC GATE TRIGGER CURRENT





3



LittleDiode supplies new, hard to find or obsolete electronic components and semiconductors all over the world.

With over two million different components listed you are sure to find the part you need.

Feel free to visit us today at our online store:

LittleDiode.com

Looking forward to providing you with the best possible service.