

### STANDARD RECOVERY DIODES

### Stud Version

#### Features

- Diffused diode
- High current carrying capability
- High voltage ratings up to 1600V
- High surge current capabilities
- Stud cathode and stud anode version

150A

#### Typical Applications

- Converters
- Power supplies
- Machine tool controls
- High power drives
- Medium traction applications

#### Major Ratings and Characteristics

Parameters	45L(R)..D	Units
$I_{F(AV)}$	150	A
@ $T_C$	150	°C
$I_{F(RMS)}$	235	A
$I_{FSM}$ @ 50Hz	3570	A
@ 60Hz	3740	A
$I^2t$ @ 50Hz	64	KA <sup>2</sup> s
@ 60Hz	58	KA <sup>2</sup> s
$V_{RRM}$ range	1200 to 1600	V
$T_J$	- 40 to 200	°C

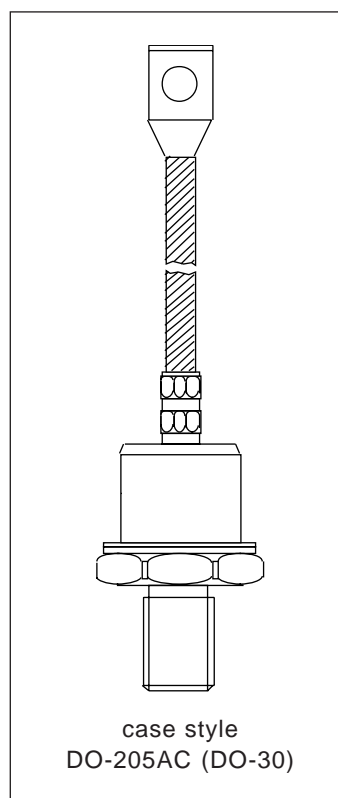

**ELECTRICAL SPECIFICATIONS**

Voltage Ratings

Type number	Voltage Code	$V_{RRM}$ , maximum repetitive peak reverse voltage V	$V_{RSM}$ , maximum non-repetitive peak rev. voltage V	$I_{RRM}$ max. @ $T_J = T_J$ max. mA
45L(R)..D	120	1200	1440	40
	160	1600	1920	

Forward Conduction

Parameter	45L(R)..D	Units	Conditions
$I_{F(AV)}$ Max. average forward current @ Case temperature	150	A	180° conduction, half sine wave
	150	°C	
$I_{F(RMS)}$ Max. RMS forward current	235	A	DC @ 142°C case temperature
$I_{FSM}$ Max. peak, one-cycle forward, non-repetitive surge current	3570	A	t = 10ms No voltage reappplied
	3740		t = 8.3ms 100% $V_{RRM}$ reappplied
	3000		t = 10ms 100% $V_{RRM}$ reappplied
	3140		t = 8.3ms 100% $V_{RRM}$ reappplied
$I^2t$ Maximum $I^2t$ for fusing	64	KA <sup>2</sup> s	t = 10ms No voltage reappplied
	58		t = 8.3ms 100% $V_{RRM}$ reappplied
	45		t = 10ms 100% $V_{RRM}$ reappplied
	41		t = 8.3ms 100% $V_{RRM}$ reappplied
$I^2\sqrt{t}$ Maximum $I^2\sqrt{t}$ for fusing	640	KA <sup>2</sup> √s	t = 0.1 to 10ms, no voltage reappplied
$V_{F(TO)1}$ Low level value of threshold voltage	0.67	V	$(16.7\% \times \pi \times I_{F(AV)} < I < \pi \times I_{F(AV)})$ , $T_J = T_J$ max.
$V_{F(TO)2}$ High level value of threshold voltage	0.83		$(I > \pi \times I_{F(AV)})$ , $T_J = T_J$ max.
$r_{f1}$ Low level value of forward slope resistance	1.42	mΩ	$(16.7\% \times \pi \times I_{F(AV)} < I < \pi \times I_{F(AV)})$ , $T_J = T_J$ max.
$r_{f2}$ High level value of forward slope resistance	0.91		$(I > \pi \times I_{F(AV)})$ , $T_J = T_J$ max.
$V_{FM}$ Max. forward voltage drop	1.33	V	$I_{pk} = 471A$ , $T_J = 25^\circ C$ , $t_p = 10ms$ sinusoidal wave

**Thermal and Mechanical Specifications**

Parameter	45L(R)..D	Units	Conditions
T <sub>J</sub> Max. junction operating temperature	-40 to 200	°C	
T <sub>stg</sub> Max. storage temperature range	-40 to 200		
R <sub>thJC</sub> Max. thermal resistance, junction to case	0.25	K/W	DC operation
R <sub>thCS</sub> Max. thermal resistance, case to heatsink	0.10		Mounting surface, smooth, flat and greased
T Max. allowed mounting torque +0 -20%	17	Nm	Not lubricated threads
	14.5		Lubricated threads
wt Approximate weight	130	g	
Case style	DO-205AC (DO-30)		See Outline Table

**ΔR<sub>thJC</sub> Conduction**

(The following table shows the increment of thermal resistance R<sub>thJC</sub> when devices operate at different conduction angles than DC)

Conduction angle	Sinusoidal conduction	Rectangular conduction	Units	Conditions
180°	0.031	0.023	K/W	T <sub>J</sub> = T <sub>J</sub> max.
120°	0.038	0.040		
90°	0.048	0.053		
60°	0.071	0.075		
30°	0.120	0.121		

**Ordering Information Table**

**Device Code**

<b>45</b>	<b>L</b>	<b>F</b>	<b>R</b>	<b>160</b>	<b>D</b>
1	2	3	4	5	6

- 1** - 45 = Standard version  
       47 = Version with Pinch Bolt (only flat base)  
       48 = Flag Top Terminal
- 2** - L = Essential Part Number
- 3** - F = Flat Base  
       None = Normal Stud
- 4** - R = Stud Reverse Polarity (Anode to Stud)  
       None = Stud Normal Polarity (Cathode to Stud)
- 5** - Voltage code: Code x 10 = V<sub>RRM</sub> (See Voltage Ratings table)
- 6** - D = Diffused diode

# 45L(R)..D Series

Bulletin I2030 rev. A 11/94



## Outline Table

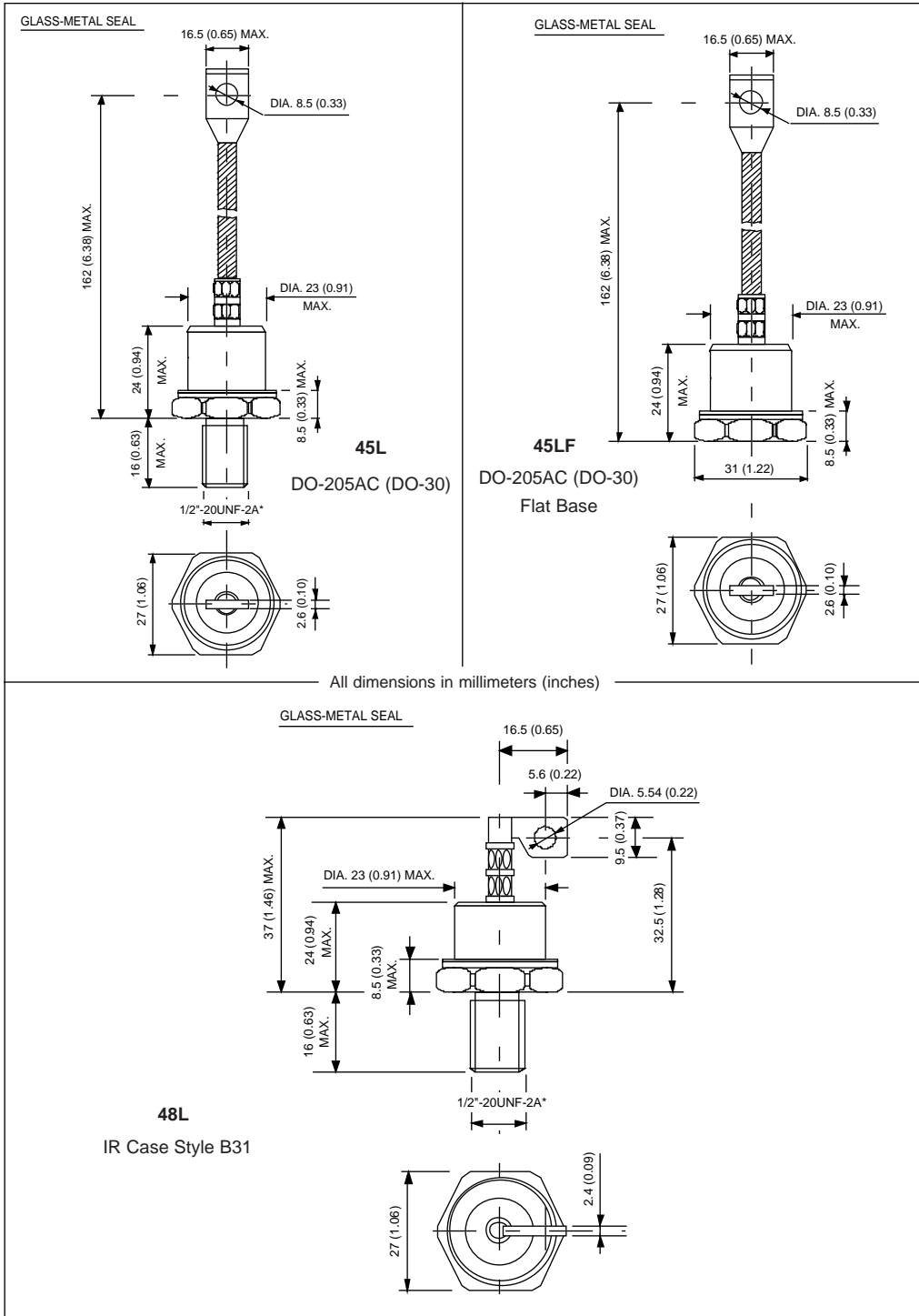

Outline Table

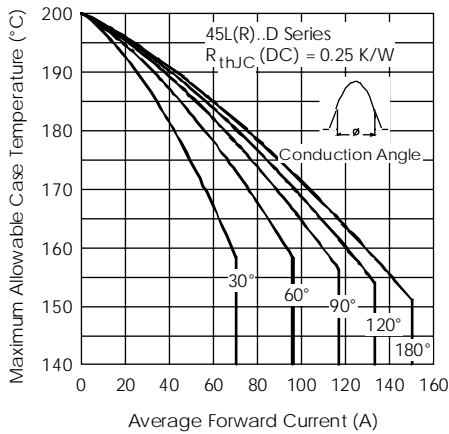
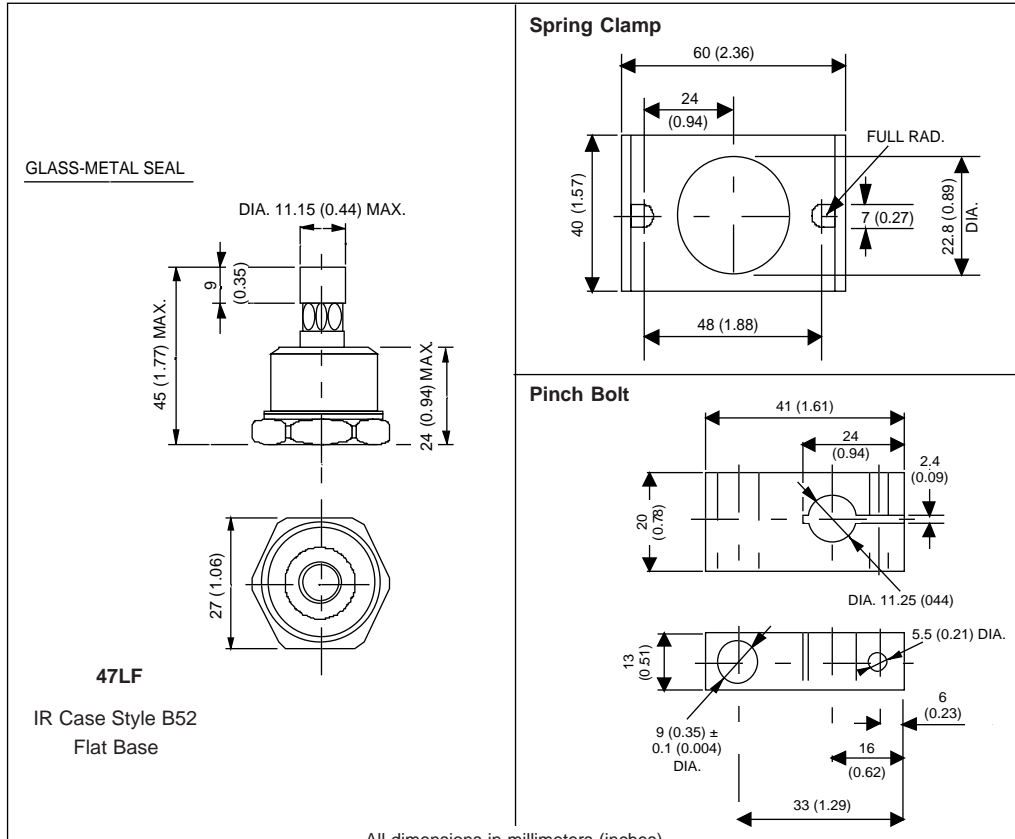

Fig. 1 - Current Ratings Characteristics

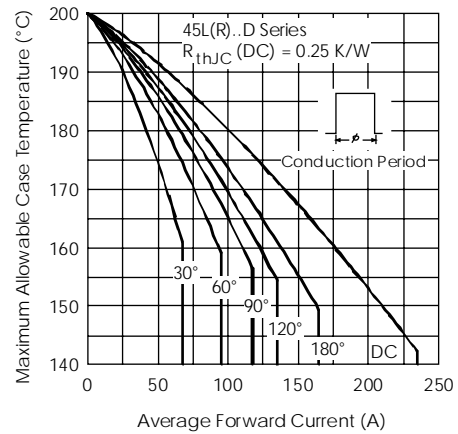

Fig. 2 - Current Ratings Characteristics

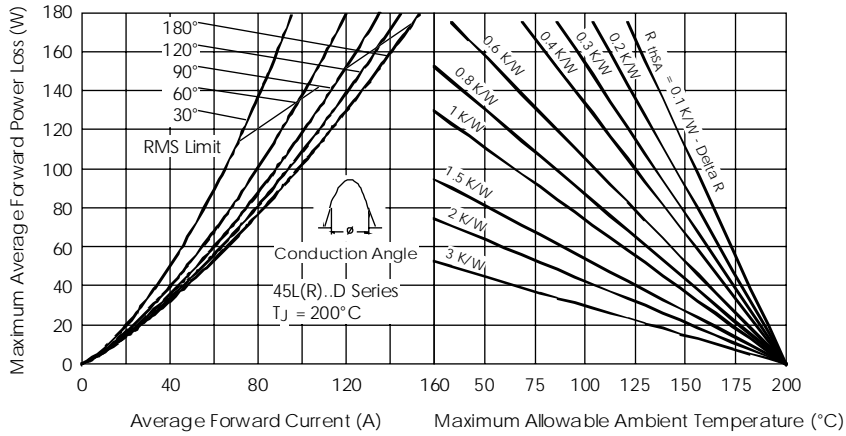

Fig. 3 - Forward Power Loss Characteristics

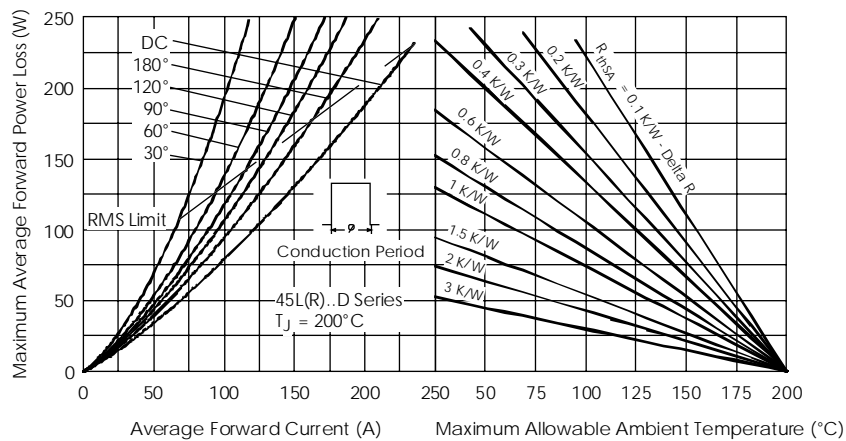

Fig. 4 - Forward Power Loss Characteristics

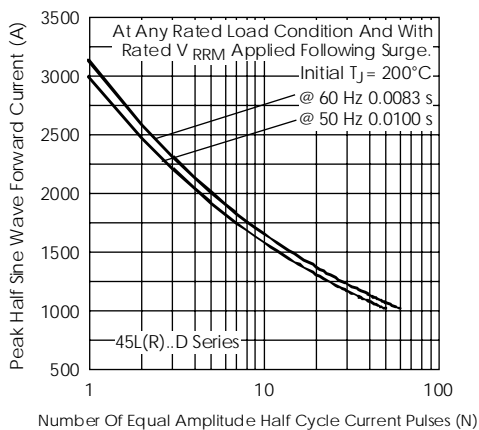

Fig. 5 - Maximum Non-Repetitive Surge Current

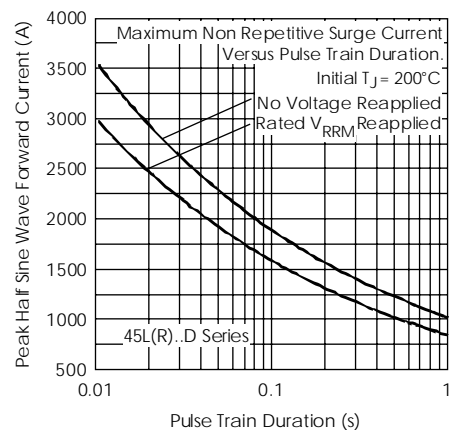

Fig. 6 - Maximum Non-Repetitive Surge Current

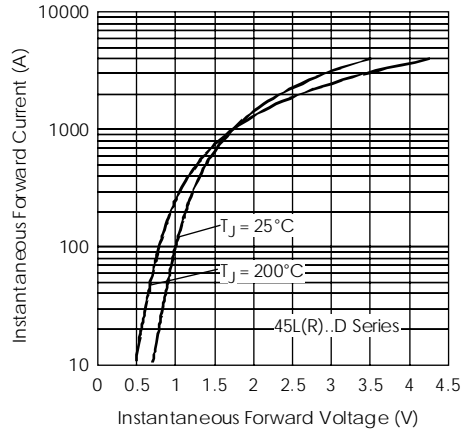

Fig. 7 - Forward Voltage Drop Characteristics

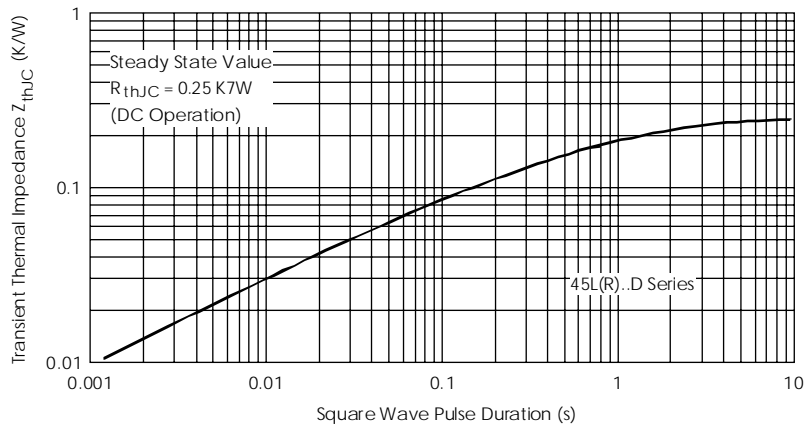

Fig. 8 - Thermal Impedance  $Z_{thJC}$  Characteristic



LittleDiode supplies new, hard to find or obsolete electronic components and semiconductors all over the world.

With over two million different components listed you are sure to find the part you need.

Feel free to visit us today at our online store:

[LittleDiode.com](http://LittleDiode.com)

Looking forward to providing you with the best possible service.