

60 Amp Schottky Rectifier SBR6090 — SBR60100

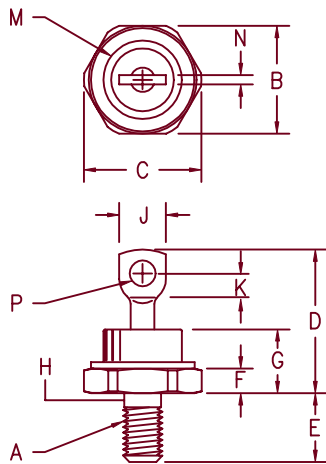

Notes:
 1. Full threads within 2 1/2 threads
 2. Standard Polarity: Stud is Cathode
 Reverse Polarity: Stud is Anode

Dim.	Inches		Millimeter		Notes
	Minimum	Maximum	Minimum	Maximum	
A	----	----	----	----	1/4-28
B	.669	.688	17.00	17.47	
C	----	.794	----	20.16	
D	.750	1.00	19.05	25.40	
E	.422	.453	10.72	11.50	
F	.115	.200	2.93	5.08	
G	----	.450	----	11.43	
H	.220	.249	5.59	6.32	1
J	----	.375	----	9.52	
K	.156	----	3.97	----	
M	----	.510	----	12.95	Dia
N	----	.080	----	2.03	
P	.140	.175	3.56	4.44	Dia

DO-203AB (DO-5)

Microsemi Catalog Number	Industry Part Number	Working Peak Reverse Voltage	Peak Reverse Voltage
SBR6090*	60HQ080 MBR6080	90V	90V
SBR60100*	60HQ100 MBR60100	100V	100V

*Add Suffix R For Reverse Polarity

- Schottky barrier rectifier
- Hermetic packaging
- Guard ring protected
- Reverse Energy Tested
- 175°C junction temperature
- VRRM – 90 to 100 Volts

Electrical Characteristics		
Average forward current	I _{F(AV)} 60 Amps	T _C = 130°C, square wave, R _{θJC} = 1.0 @/W
Maximum surge current	I _{FSM} 1000 Amps	8.3ms, half sine, T _J = 175°C
Max repetitive peak reverse current	I _{R(OV)} 2 Amp	f = 1 KHz, 25°C, 1 μsec square wave
Max peak forward voltage	V _{FM} .89 Volts	I _{FM} = 60A: 25°C *
Max peak forward voltage	V _{FM} .70 Volts	I _{FM} = 60A: 125°C *
Max peak reverse current	I _{RM} 50 mA	V _{RRM, T_J} = 125°C *
Max peak reverse current	I _{RM} 1.0 mA	V _{RRM, T_J} = 25°C
Typical junction capacitance	C _J 1250 pF	V _R = 5.0V, T _J = 25°C

*Pulse test: Pulse width 300 μsec, Duty cycle 2%

Thermal and Mechanical Characteristics		
Storage temp range	T _{STG}	-65°C to 175°C
Operating junction temp range	T _J	-65°C to 175°C
Maximum thermal resistance	R _{θJC}	1.0°C/W Junction to case
Typical thermal resistance (greased)	R _{θCS}	0.5°C/W Case to sink
Mounting torque		25-30 inch pounds
Weight		.54 ounces (15.3 grams) typical

SBR6090 — SBR60100

Figure 1
Typical Forward Characteristics

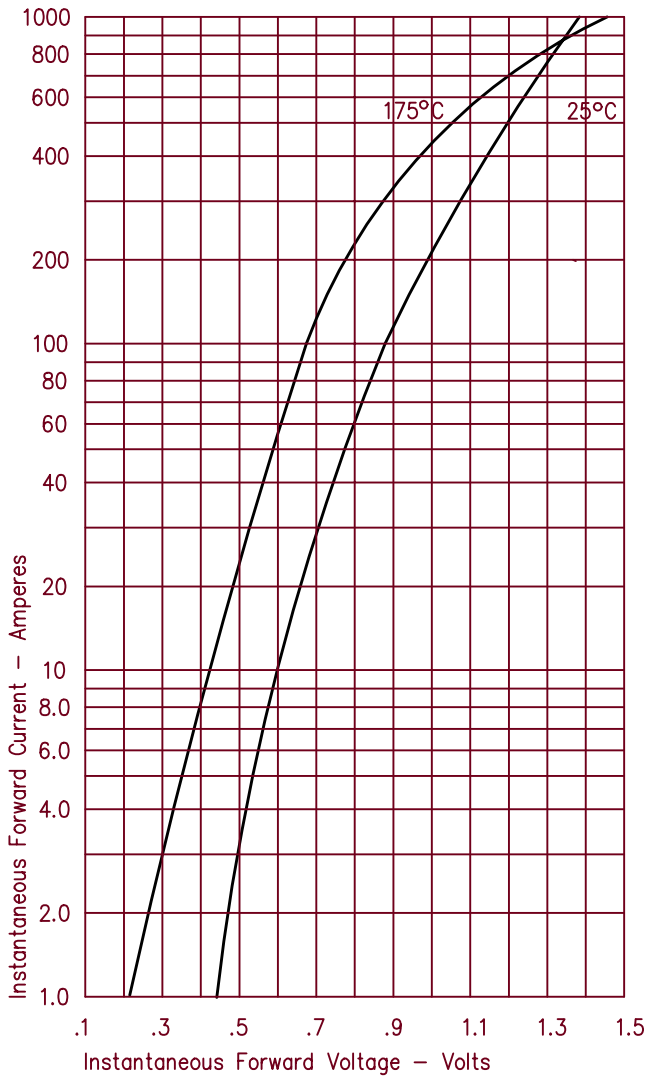

Figure 3
Typical Junction Capacitance

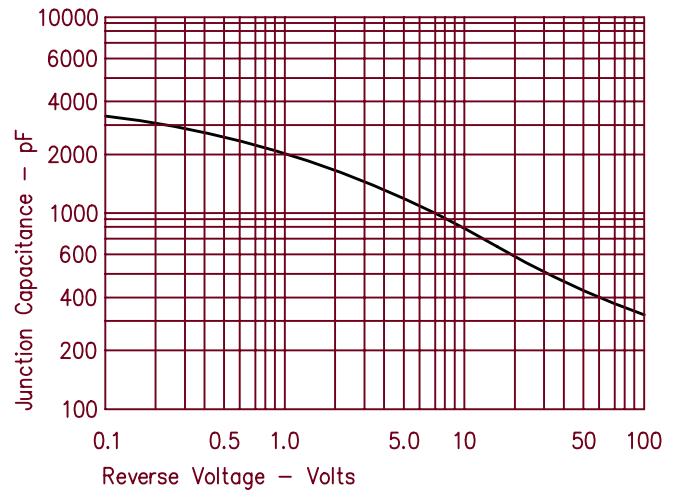

Figure 4
Forward Current Derating

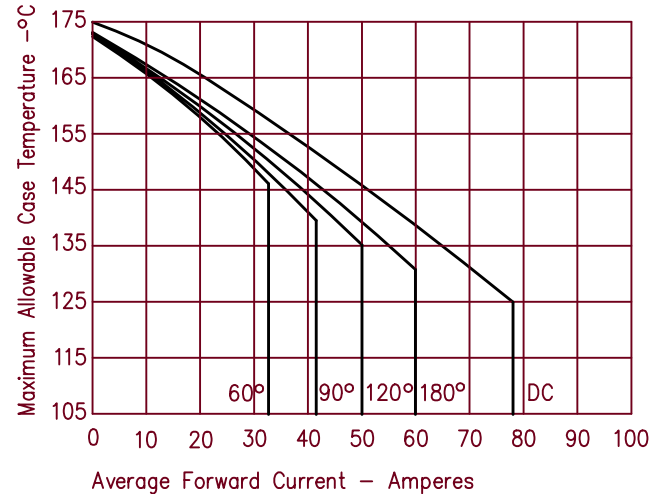

Figure 2
Typical Reverse Characteristics

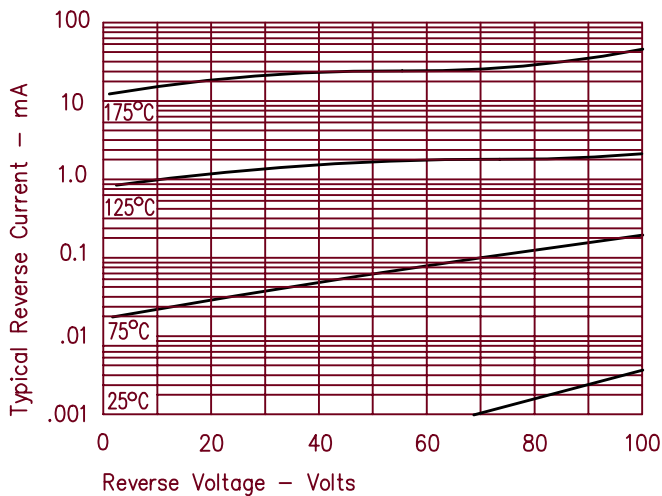
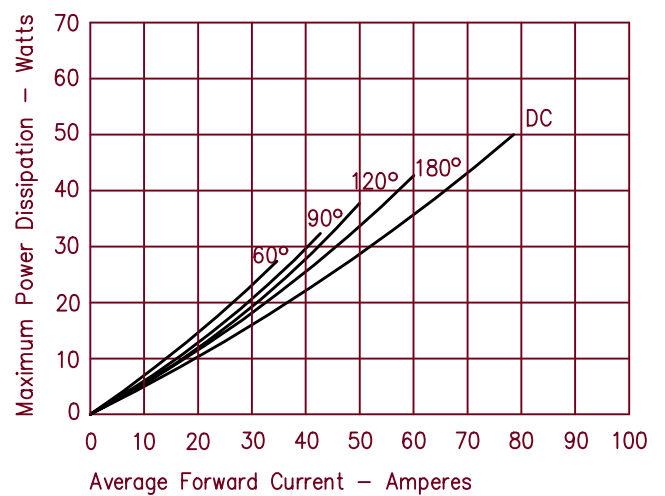

Figure 5
Maximum Forward Power Dissipation





LittleDiode supplies new, hard to find or obsolete electronic components and semiconductors all over the world.

With over two million different components listed you are sure to find the part you need.

Feel free to visit us today at our online store:

LittleDiode.com

Looking forward to providing you with the best possible service.