

# DATA SHEET

**74F164**

8-bit serial-in parallel-out shift register

Product specification

1995 Sep 22

IC15 Data Handbook

# 8-bit serial-in parallel-out shift register

# 74F164

## FEATURES

- Gated serial data inputs
- Typical shift frequency of 100MHz
- Asynchronous Master Reset
- Buffered clock and data inputs
- Fully synchronous data transfer
- Industrial temperature range available (-40°C to +85°C)

## DESCRIPTION

The 74F164 is an 8-bit edge-triggered shift register with serial data entry and an output from each of the eight stages. Data is entered through one of two inputs (Dsa, Dsb); either input can be used as an active High enable for data entry through the other input. Both inputs must be connected together or an unused input must be tied High.

Data shifts one place to the right on each Low-to-High transition of the clock (CP) input, and enters into Q0 the logical AND of the two data inputs (Dsa, Dsb) that existed one setup time before the rising edge. A Low level on the Master Reset ( $\overline{MR}$ ) input overrides all other inputs and clears the register asynchronously, forcing all outputs Low.

## ORDERING INFORMATION

DESCRIPTION	ORDER CODE		DRAWING NUMBER
	COMMERCIAL RANGE $V_{CC} = 5V \pm 10\%$ , $T_{amb} = 0^\circ C$ to $+70^\circ C$	INDUSTRIAL RANGE $V_{CC} = 5V \pm 10\%$ , $T_{amb} = -40^\circ C$ to $+85^\circ C$	
14-pin plastic DIP	74F164N	I74F164N	SOT27-1
14-pin plastic SO	74F164D	I74F164D	SOT108-1

## PIN CONFIGURATION

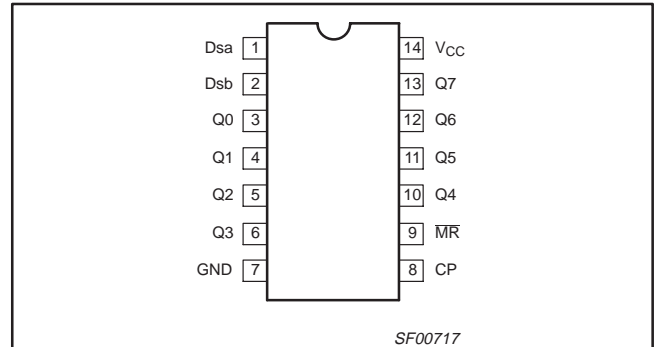

TYPE	TYPICAL $f_{max}$	TYPICAL SUPPLY CURRENT (TOTAL)
74F164	100MHz	33mA

## INPUT AND OUTPUT LOADING AND FAN OUT TABLE

PINS	DESCRIPTION	74F (U.L.) HIGH/LOW	LOAD VALUE HIGH/LOW
Dsa, Dsb	Data inputs	1.0/1.0	20µA/0.6mA
CP	Clock pulse input (active rising edge)	1.0/1.0	20µA/0.6mA
$\overline{MR}$	Master reset input (active-Low)	1.0/1.0	20µA/0.6mA
Q0 – Q7	Data outputs	50/33	1.0mA/20mA

One (1.0) FAST unit load is defined as: 20µA in the High state and 0.6mA in the Low state.

## LOGIC SYMBOL

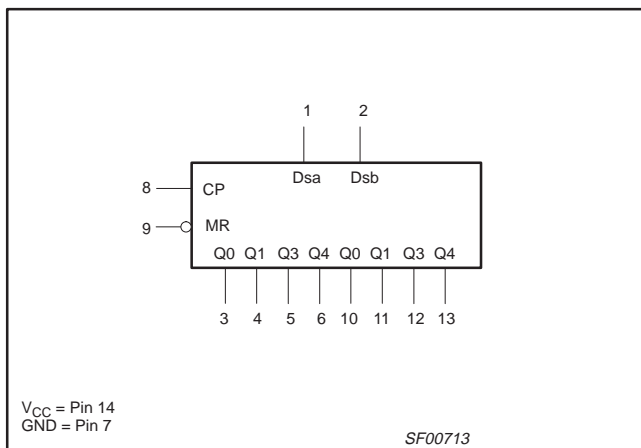

## IEC/IEEE SYMBOL

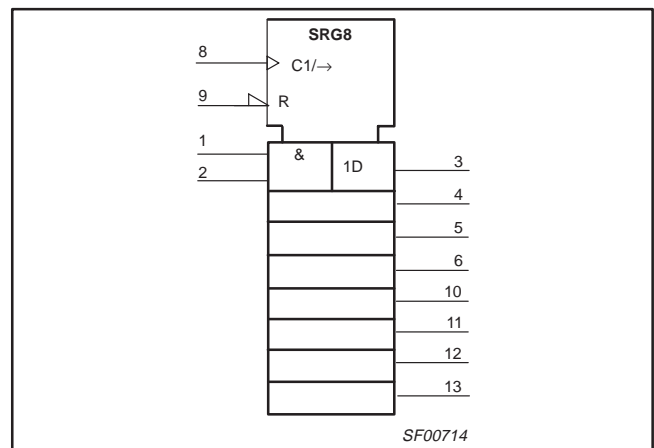

# 8-bit serial-in parallel-out shift register

74F164

## LOGIC DIAGRAM

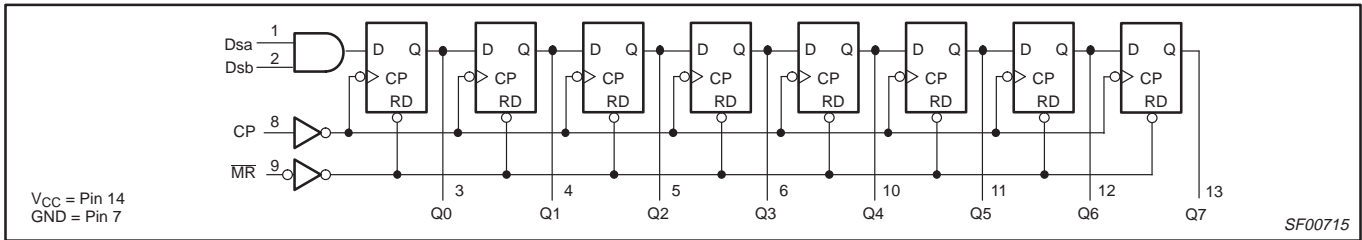

## FUNCTION TABLE

INPUTS				OUTPUTS								OPERATING MODE	
MR	CP	Dsa	Dsb	Q0	Q1	Q2	Q3	Q4	Q5	Q6	Q7		
L	X	X	X	L	L	L	L	L	L	L	L	L	Reset (Clear)
H	↑	l	l	L	q0	q1	q2	q3	q4	q5	q6	q6	Shift
H	↑	h	l	L	q0	q1	q2	q3	q4	q5	q6	q6	
H	↑	h	h	H	q0	q1	q2	q3	q4	q5	q6	q6	

H = High voltage level  
 h = High voltage level one setup time prior to the Low-to-High clock transition.  
 L = Low voltage level  
 l = Low voltage level one setup time prior to the Low-to-High clock transition.  
 qn = Lower case letter indicate the state of the referenced output one setup time prior to the Low-to-High clock transition.  
 X = Don't care  
 ↑ = Low-to-High clock transition

## ABSOLUTE MAXIMUM RATINGS

(Operation beyond the limit set forth in this table may impair the useful life of the device. Unless otherwise noted these limits are over the operating free air temperature range.)

SYMBOL	PARAMETER	RATING	UNIT
V <sub>CC</sub>	Supply voltage	-0.5 to +7.0	V
V <sub>IN</sub>	Input voltage	-0.5 to +7.0	V
I <sub>IN</sub>	Input current	-30 to +5	mA
V <sub>OUT</sub>	Voltage applied to output in High output state	-0.5 to V <sub>CC</sub>	V
I <sub>OUT</sub>	Current applied to output in Low output state	40	mA
T <sub>amb</sub>	Operating free-air temperature range	Commercial Range	0 to +70
		Industrial Range	-40 to +85
T <sub>stg</sub>	Storage temperature range	-65 to +150	°C

## RECOMMENDED OPERATING CONDITIONS

SYMBOL	PARAMETER	LIMIT			UNIT
		MIN	NOM	MAX	
V <sub>CC</sub>	Supply voltage	4.5	5.0	5.5	V
V <sub>IH</sub>	High-level input voltage	2.0			V
V <sub>IL</sub>	Low-level input voltage			0.8	V
I <sub>Ik</sub>	Input clamp current			-18	mA
I <sub>OH</sub>	High-level output current			-1	mA
I <sub>OL</sub>	Low-level output current			20	mA
T <sub>amb</sub>	Operating free-air temperature range	Commercial Range	0	+70	°C
		Industrial Range	-40	+85	

# 8-bit serial-in parallel-out shift register

# 74F164

## DC ELECTRICAL CHARACTERISTICS

(Over recommended operating free-air temperature range unless otherwise noted.)

SYMBOL	PARAMETER	TEST CONDITIONS <sup>1</sup>	LIMITS			UNIT	
			MIN	TYP <sup>2</sup>	MAX		
V <sub>OH</sub>	High-level output voltage	V <sub>CC</sub> = MIN, V <sub>IL</sub> = MAX, V <sub>IH</sub> = MIN, I <sub>OH</sub> = MAX	±10%V <sub>CC</sub>	2.5		V	
			±5%V <sub>CC</sub>	2.7	3.4	V	
V <sub>OL</sub>	Low-level output voltage	V <sub>CC</sub> = MIN, V <sub>IL</sub> = MAX, V <sub>IH</sub> = MIN, I <sub>OL</sub> = MAX	±10%V <sub>CC</sub>		0.30	0.50	V
			±5%V <sub>CC</sub>		0.30	0.50	V
V <sub>IK</sub>	Input clamp voltage	V <sub>CC</sub> = MIN, I <sub>I</sub> = I <sub>IK</sub>		-0.73	-1.2	V	
I <sub>I</sub>	Input current at maximum input voltage	V <sub>CC</sub> = MAX, V <sub>I</sub> = 7.0V			100	μA	
I <sub>IH</sub>	High-level input current	V <sub>CC</sub> = MAX, V <sub>I</sub> = 2.7V			20	μA	
I <sub>ILL</sub>	Low-level input current	V <sub>CC</sub> = MAX, V <sub>I</sub> = 0.5V			-0.6	mA	
I <sub>OS</sub>	Short-circuit output current <sup>3</sup>	V <sub>CC</sub> = MAX	-60		-150	mA	
I <sub>CC</sub>	Supply current (total) <sup>4</sup>	V <sub>CC</sub> = MAX		33	55	mA	

### Notes to DC electrical characteristics

1. For conditions shown as MIN or MAX, use the appropriate value specified under recommended operating conditions for the applicable type.
2. All typical values are at V<sub>CC</sub> = 5V, T<sub>amb</sub> = 25°C.
3. Not more than one output should be shorted at a time. For testing I<sub>OS</sub>, the use of high-speed test apparatus and/or sample-and-hold techniques are preferable in order to minimize internal heating and more accurately reflect operational values. Otherwise, prolonged shorting of a High output may raise the chip temperature well above normal and thereby cause invalid readings in other parameter tests. In any sequence of parameter test, I<sub>OS</sub> tests should be performed last.
4. Measure I<sub>CC</sub> with the serial inputs grounded, the clock input at 2.4V, and a momentary ground, then applied to Master Reset, and all outputs open.

## APPLICATION

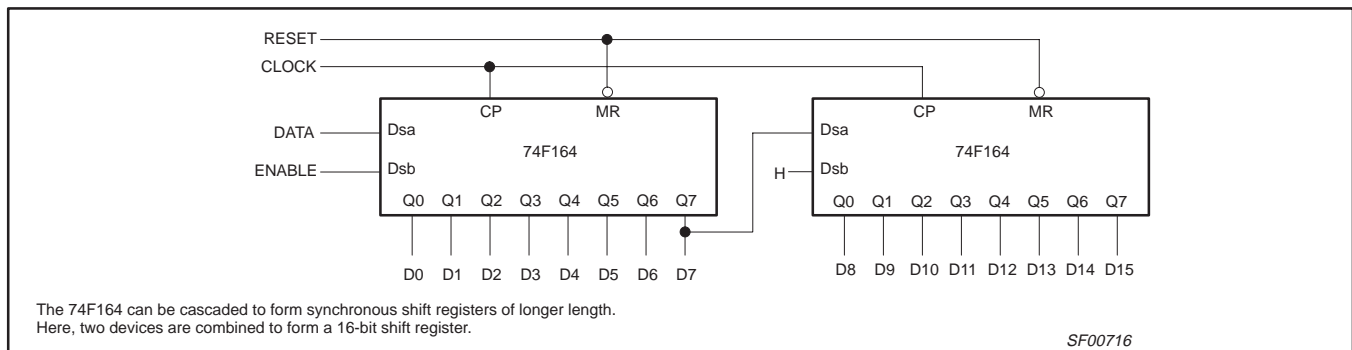

# 8-bit serial-in parallel-out shift register

74F164

## AC ELECTRICAL CHARACTERISTICS

SYMBOL	PARAMETER	TEST CONDITION	LIMITS						UNIT	
			$T_{amb} = +25^{\circ}\text{C}$ $V_{CC} = 5\text{V}$ $C_L = 50\text{pF}$ $R_L = 500\Omega$			$T_{amb} = 0^{\circ}\text{C to } +70^{\circ}\text{C}$ $V_{CC} = +5\text{V}\pm 10\%$ $C_L = 50\text{pF}$ $R_L = 500\Omega$		$T_{amb} = -40^{\circ}\text{C to } +85^{\circ}\text{C}$ $V_{CC} = +5\text{V}\pm 10\%$ $C_L = 50\text{pF}$ $R_L = 500\Omega$		
			MIN	TYP	MAX	MIN	MAX	MIN		MAX
$f_{max}$	Maximum clock frequency	Waveform 1	80	100		80		80		MHz
$t_{PLH}$ $t_{PHL}$	Propagation delay CP to Qn	Waveform 1	3.0 5.0	5.0 7.0	8.0 10.0	2.5 5.0	9.0 11.0	2.5 5.0	9.0 11.0	ns
$t_{PHL}$	Propagation delay MR to Qn	Waveform 3	5.5	7.5	10.5	5.5	11.5	5.5	11.5	ns

## AC SETUP REQUIREMENTS

SYMBOL	PARAMETER	TEST CONDITION	LIMITS						UNIT	
			$T_{amb} = +25^{\circ}\text{C}$ $V_{CC} = 5\text{V}$ $C_L = 50\text{pF}$ $R_L = 500\Omega$			$T_{amb} = 0^{\circ}\text{C to } +70^{\circ}\text{C}$ $V_{CC} = +5\text{V}\pm 10\%$ $C_L = 50\text{pF}$ $R_L = 500\Omega$		$T_{amb} = -40^{\circ}\text{C to } +85^{\circ}\text{C}$ $V_{CC} = +5\text{V}\pm 10\%$ $C_L = 50\text{pF}$ $R_L = 500\Omega$		
			MIN	TYP	MAX	MIN	MAX	MIN		MAX
$t_{S(H)}$ $t_{S(L)}$	Setup time, High or Low Dn to CP	Waveform 2	7.0 7.0			7.0 7.0		7.0 7.0		ns
$t_{H(H)}$ $t_{H(L)}$	Hold time, High or Low Dn to CP	Waveform 2	1.0 1.0			2.0 2.0		2.0 2.0		ns
$t_{W(H)}$ $t_{W(L)}$	CP Pulse width High or Low	Waveform 1	4.0 7.0			4.0 7.0		4.0 7.0		ns
$t_{W(L)}$	MR Pulse width Low	Waveform 3	7.0			7.0		7.0		ns
$t_{REC}$	Recovery time MR to CP	Waveform 3	7.0			7.0		7.0		ns

## AC WAVEFORMS

For all waveforms,  $V_M = 1.5\text{V}$ .

The shaded areas indicate when the input is permitted to change for predictable output performance.

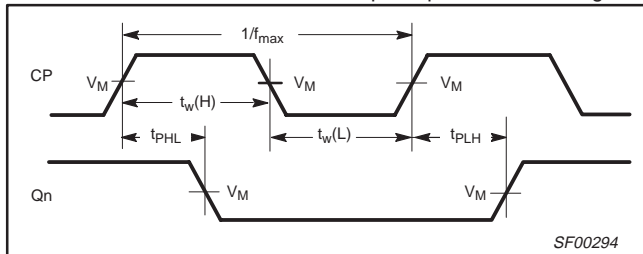

Waveform 1. Propagation delay for Clock input to output, Clock Pulse width, and maximum Clock frequency

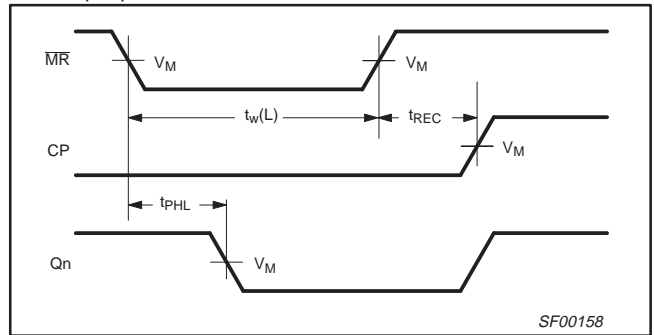

Waveform 3. Master Reset pulse width, Master Reset to output delay and Master Reset to Clock recovery time

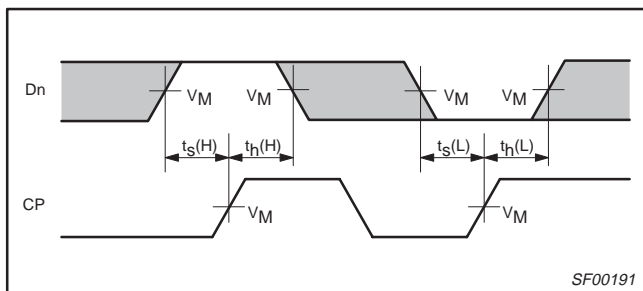

Waveform 2. Data setup and hold times

# 8-bit serial-in parallel-out shift register

# 74F164

## TEST CIRCUIT AND WAVEFORMS

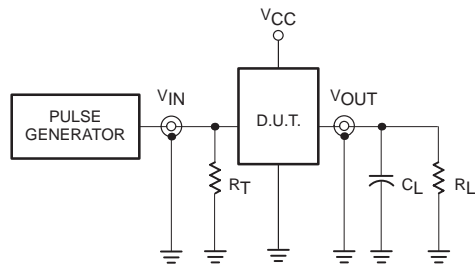

Test Circuit for Totem-Pole Outputs

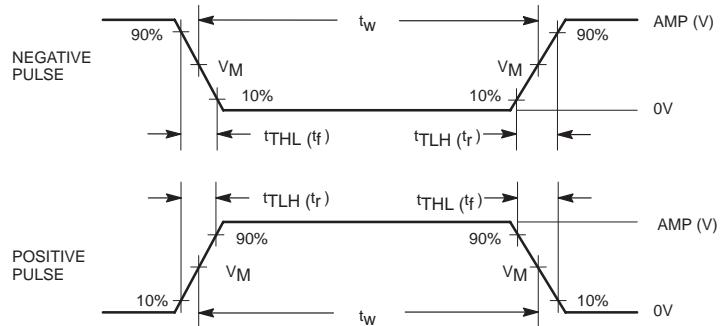

Input Pulse Definition

**DEFINITIONS:**

- $R_L$  = Load resistor; see AC ELECTRICAL CHARACTERISTICS for value.
- $C_L$  = Load capacitance includes jig and probe capacitance; see AC ELECTRICAL CHARACTERISTICS for value.
- $R_T$  = Termination resistance should be equal to  $Z_{OUT}$  of pulse generators.

family	INPUT PULSE REQUIREMENTS					
	amplitude	$V_M$	rep. rate	$t_w$	$t_{TLH}$	$t_{THL}$
74F	3.0V	1.5V	1MHz	500ns	2.5ns	2.5ns

SF00006

# 8-bit serial-in parallel-out shift register

## 74F164

DIP14: plastic dual in-line package; 14 leads (300 mil)

SOT27-1

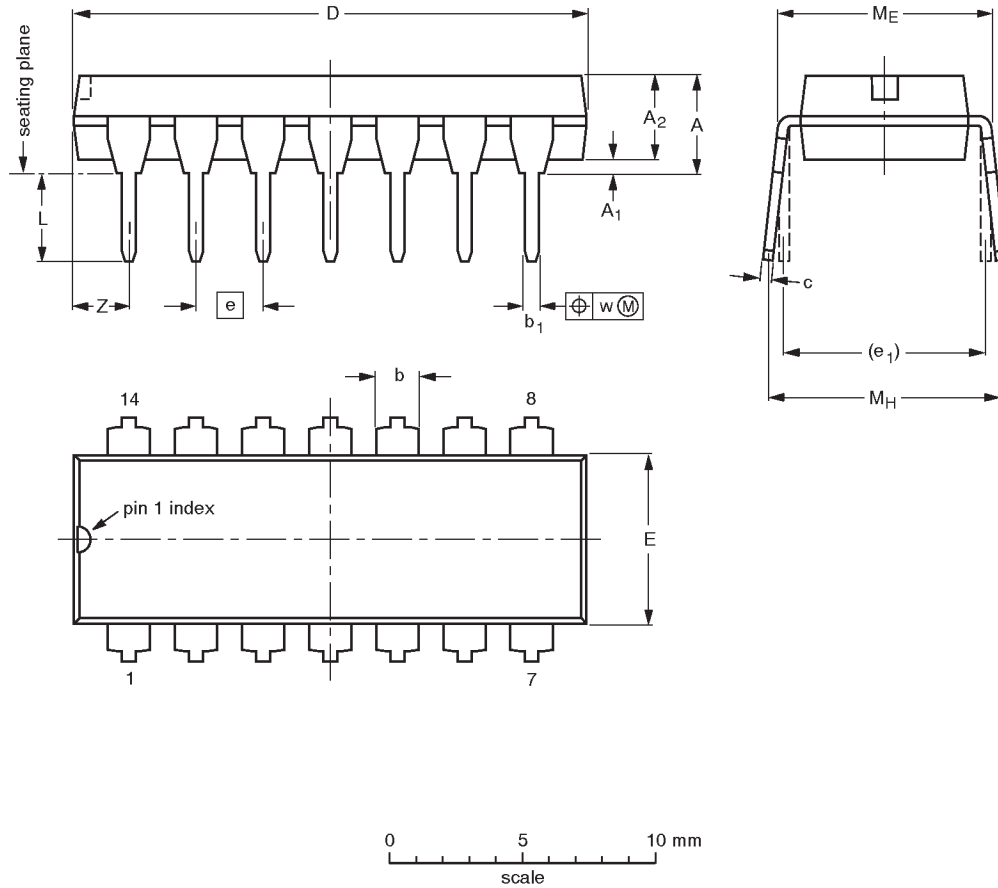

**DIMENSIONS (inch dimensions are derived from the original mm dimensions)**

UNIT	A max.	A <sub>1</sub> min.	A <sub>2</sub> max.	b	b <sub>1</sub>	c	D <sup>(1)</sup>	E <sup>(1)</sup>	e	e <sub>1</sub>	L	M <sub>E</sub>	M <sub>H</sub>	w	Z <sup>(1)</sup> max.
mm	4.2	0.51	3.2	1.73 1.13	0.53 0.38	0.36 0.23	19.50 18.55	6.48 6.20	2.54	7.62	3.60 3.05	8.25 7.80	10.0 8.3	0.254	2.2
inches	0.17	0.020	0.13	0.068 0.044	0.021 0.015	0.014 0.009	0.77 0.73	0.26 0.24	0.10	0.30	0.14 0.12	0.32 0.31	0.39 0.33	0.01	0.087

**Note**

1. Plastic or metal protrusions of 0.25 mm maximum per side are not included.

OUTLINE VERSION	REFERENCES			EUROPEAN PROJECTION	ISSUE DATE
	IEC	JEDEC	EIAJ		
SOT27-1	050G04	MO-001AA			92-11-17 95-03-11

# 8-bit serial-in parallel-out shift register

## 74F164

**SO14: plastic small outline package; 14 leads; body width 3.9 mm**

**SOT108-1**

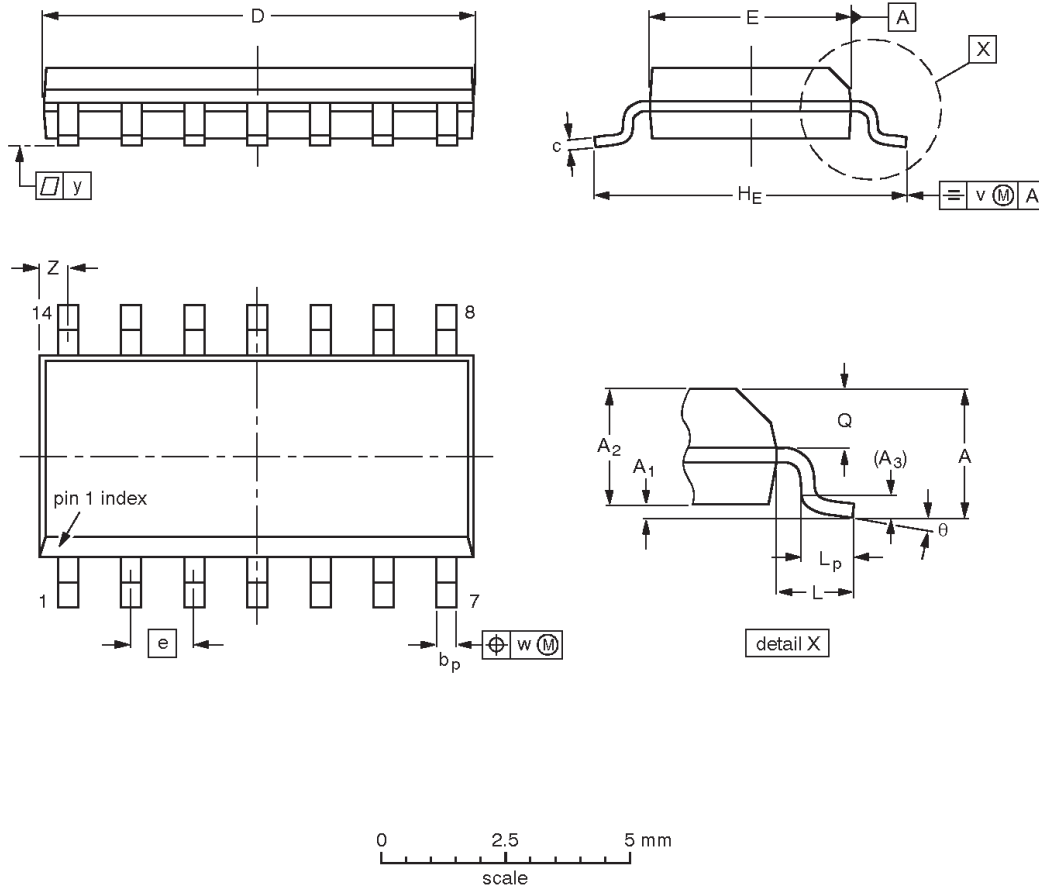

**DIMENSIONS (inch dimensions are derived from the original mm dimensions)**

UNIT	A max.	A <sub>1</sub>	A <sub>2</sub>	A <sub>3</sub>	b <sub>p</sub>	c	D <sup>(1)</sup>	E <sup>(1)</sup>	e	H <sub>E</sub>	L	L <sub>p</sub>	Q	v	w	y	Z <sup>(1)</sup>	θ
mm	1.75	0.25 0.10	1.45 1.25	0.25	0.49 0.36	0.25 0.19	8.75 8.55	4.0 3.8	1.27	6.2 5.8	1.05	1.0 0.4	0.7 0.6	0.25	0.25	0.1	0.7 0.3	8° 0°
inches	0.069	0.010 0.004	0.057 0.049	0.01	0.019 0.014	0.0100 0.0075	0.35 0.34	0.16 0.15	0.050	0.244 0.228	0.041	0.039 0.016	0.028 0.024	0.01	0.01	0.004	0.028 0.012	

**Note**

1. Plastic or metal protrusions of 0.15 mm maximum per side are not included.

OUTLINE VERSION	REFERENCES			EUROPEAN PROJECTION	ISSUE DATE
	IEC	JEDEC	EIAJ		
SOT108-1	076E06S	MS-012AB			95-01-29 97-05-22

---

8-bit serial-in parallel-out shift register

74F164

---

**NOTES**

## 8-bit serial-in parallel-out shift register

74F164

## Data sheet status

Data sheet status	Product status	Definition [1]
Objective specification	Development	This data sheet contains the design target or goal specifications for product development. Specification may change in any manner without notice.
Preliminary specification	Qualification	This data sheet contains preliminary data, and supplementary data will be published at a later date. Philips Semiconductors reserves the right to make changes at any time without notice in order to improve design and supply the best possible product.
Product specification	Production	This data sheet contains final specifications. Philips Semiconductors reserves the right to make changes at any time without notice in order to improve design and supply the best possible product.

[1] Please consult the most recently issued datasheet before initiating or completing a design.

## Definitions

**Short-form specification** — The data in a short-form specification is extracted from a full data sheet with the same type number and title. For detailed information see the relevant data sheet or data handbook.

**Limiting values definition** — Limiting values given are in accordance with the Absolute Maximum Rating System (IEC 134). Stress above one or more of the limiting values may cause permanent damage to the device. These are stress ratings only and operation of the device at these or at any other conditions above those given in the Characteristics sections of the specification is not implied. Exposure to limiting values for extended periods may affect device reliability.

**Application information** — Applications that are described herein for any of these products are for illustrative purposes only. Philips Semiconductors make no representation or warranty that such applications will be suitable for the specified use without further testing or modification.

## Disclaimers

**Life support** — These products are not designed for use in life support appliances, devices or systems where malfunction of these products can reasonably be expected to result in personal injury. Philips Semiconductors customers using or selling these products for use in such applications do so at their own risk and agree to fully indemnify Philips Semiconductors for any damages resulting from such application.

**Right to make changes** — Philips Semiconductors reserves the right to make changes, without notice, in the products, including circuits, standard cells, and/or software, described or contained herein in order to improve design and/or performance. Philips Semiconductors assumes no responsibility or liability for the use of any of these products, conveys no license or title under any patent, copyright, or mask work right to these products, and makes no representations or warranties that these products are free from patent, copyright, or mask work right infringement, unless otherwise specified.

Philips Semiconductors  
811 East Arques Avenue  
P.O. Box 3409  
Sunnyvale, California 94088-3409  
Telephone 800-234-7381

© Copyright Philips Electronics North America Corporation 1998  
All rights reserved. Printed in U.S.A.

print code

Date of release: 10-98

Document order number:

9397-750-05085

*Let's make things better.*



LittleDiode supplies new, hard to find or obsolete electronic components and semiconductors all over the world.

With over two million different components listed you are sure to find the part you need.

Feel free to visit us today at our online store:

[LittleDiode.com](http://LittleDiode.com)

Looking forward to providing you with the best possible service.