

74HC40103

8-bit synchronous binary down counter

Rev. 03 — 12 November 2004

Product data sheet

1. General description

The 74HC40103 is a high-speed Si-gate CMOS device and are pin compatible with the 40103 of the 4000B series. The 74HC40103 is specified in compliance with JEDEC standard no. 7A.

The 74HC40103 consists of an 8-bit synchronous down counter with a single output which is active when the internal count is zero. The 74HC40103 contains a single 8-bit binary counter and has control inputs for enabling or disabling the clock (CP), for clearing the counter to its maximum count and for presetting the counter either synchronously or asynchronously. All control inputs and the terminal count output (\overline{TC}) are active-LOW logic.

In normal operation, the counter is decremented by one count on each positive-going transition of the clock (CP). Counting is inhibited when the terminal enable input (\overline{TE}) is HIGH. The terminal count output (\overline{TC}) goes LOW when the count reaches zero if \overline{TE} is LOW, and remains LOW for one full clock period.

When the synchronous preset enable input (\overline{PE}) is LOW, data at the jam input (P0 to P7) is clocked into the counter on the next positive-going clock transition regardless of the state of \overline{TE} . When the asynchronous preset enable input (\overline{PL}) is LOW, data at the jam input (P0 to P7) is asynchronously forced into the counter regardless of the state of \overline{PE} , \overline{TE} , or CP. The jam inputs (P0 to P7) represent a single 8-bit binary word.

When the master reset input (\overline{MR}) is LOW, the counter is asynchronously cleared to its maximum count (decimal 255) regardless of the state of any other input.

If all control inputs except \overline{TE} are HIGH at the time of zero count, the counters will jump to the maximum count, giving a counting sequence of 256 clock pulses long.

The 74HC40103 may be cascaded using the \overline{TE} input and the \overline{TC} output, in either a synchronous or ripple mode.

PHILIPS

2. Features

- Cascadable
- Synchronous or asynchronous preset
- Low-power dissipation
- Complies with JEDEC standard no. 7A
- ESD protection:
 - ◆ HBM EIA/JESD22-A114-B exceeds 2000 V
 - ◆ MM EIA/JESD22-A115-A exceeds 200 V.
- Multiple package options
- Specified from $-40\text{ }^{\circ}\text{C}$ to $+80\text{ }^{\circ}\text{C}$ and from $-40\text{ }^{\circ}\text{C}$ to $+125\text{ }^{\circ}\text{C}$.

3. Applications

- Divide-by-n counters
- Programmable timers
- Interrupt timers
- Cycle/program counters.

4. Quick reference data

Table 1: Quick reference data

$GND = 0\text{ V}$; $T_{amb} = 25\text{ }^{\circ}\text{C}$; $t_r = t_f = 6\text{ ns}$.

Symbol	Parameter	Conditions	Min	Typ	Max	Unit
t_{PHL} , t_{PLH}	propagation delay CP to \overline{TC}	$C_L = 15\text{ pF}$; $V_{CC} = 5\text{ V}$	-	30	-	ns
f_{max}	maximum clock frequency	$C_L = 15\text{ pF}$; $V_{CC} = 5\text{ V}$	-	32	-	MHz
C_I	input capacitance		-	3.5	-	pF
C_{PD}	power dissipation capacitance	$V_I = GND\text{ to }V_{CC}$	[1] -	24	-	pF

[1] C_{PD} is used to determine the dynamic power dissipation (P_D in μW).

$$P_D = C_{PD} \times V_{CC}^2 \times f_i \times N + \sum(C_L \times V_{CC}^2 \times f_o) \text{ where:}$$

f_i = input frequency in MHz;

f_o = output frequency in MHz;

C_L = output load capacitance in pF;

V_{CC} = supply voltage in V;

N = number of inputs switching;

$\sum(C_L \times V_{CC}^2 \times f_o)$ = sum of outputs.

5. Ordering information

Table 2: Ordering information

Type number	Package			Version
	Temperature range	Name	Description	
74HC40103N	-40 °C to +125 °C	DIP16	plastic dual in-line package; 16 leads (300 mil)	SOT38-4
74HC40103D	-40 °C to +125 °C	SO16	plastic small outline package; 16 leads; body width 3.9 mm	SOT109-1
74HC40103DB	-40 °C to +125 °C	SSOP16	plastic shrink small outline package; 16 leads; body width 5.3 mm	SOT338-1
74HC40103PW	-40 °C to +125 °C	TSSOP16	plastic thin shrink small outline package; 16 leads; body width 4.4 mm	SOT403-1

6. Functional diagram

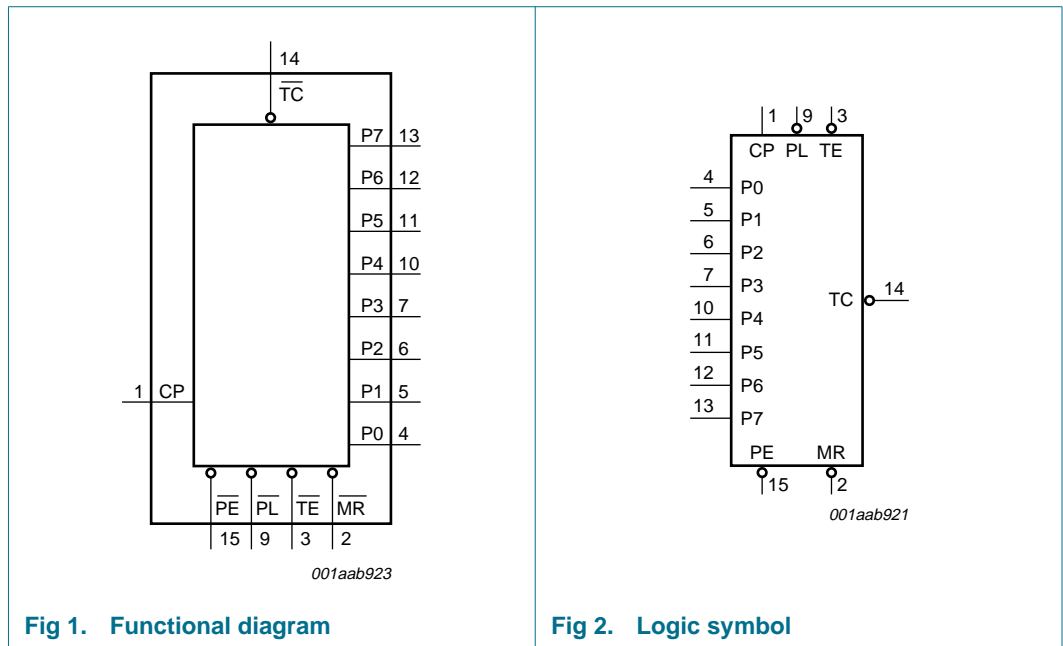

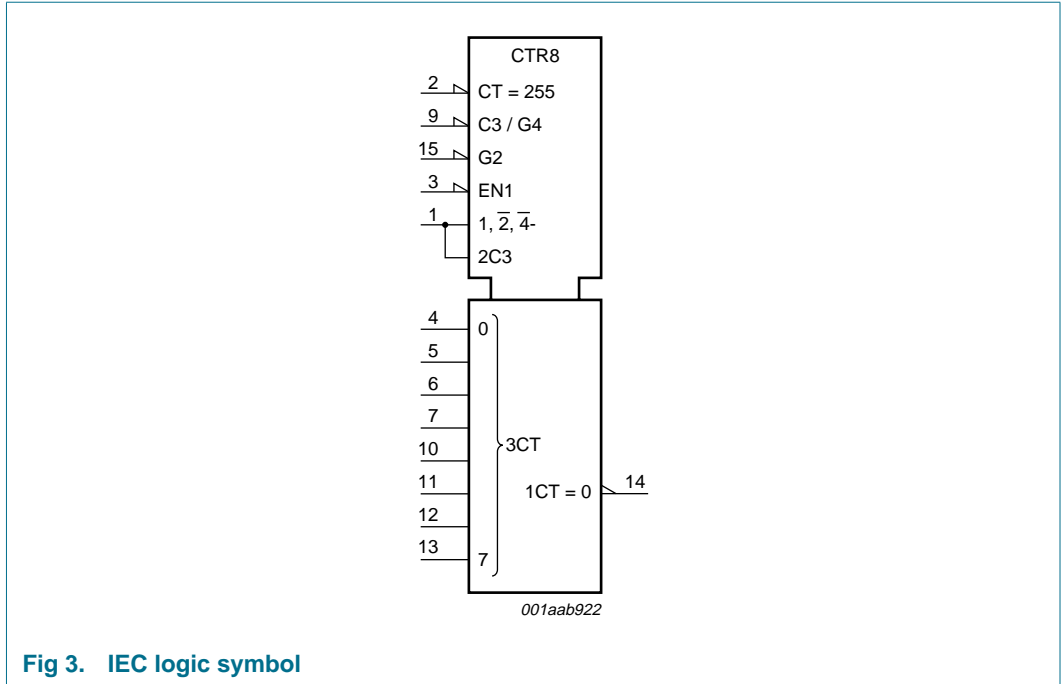

Fig 3. IEC logic symbol

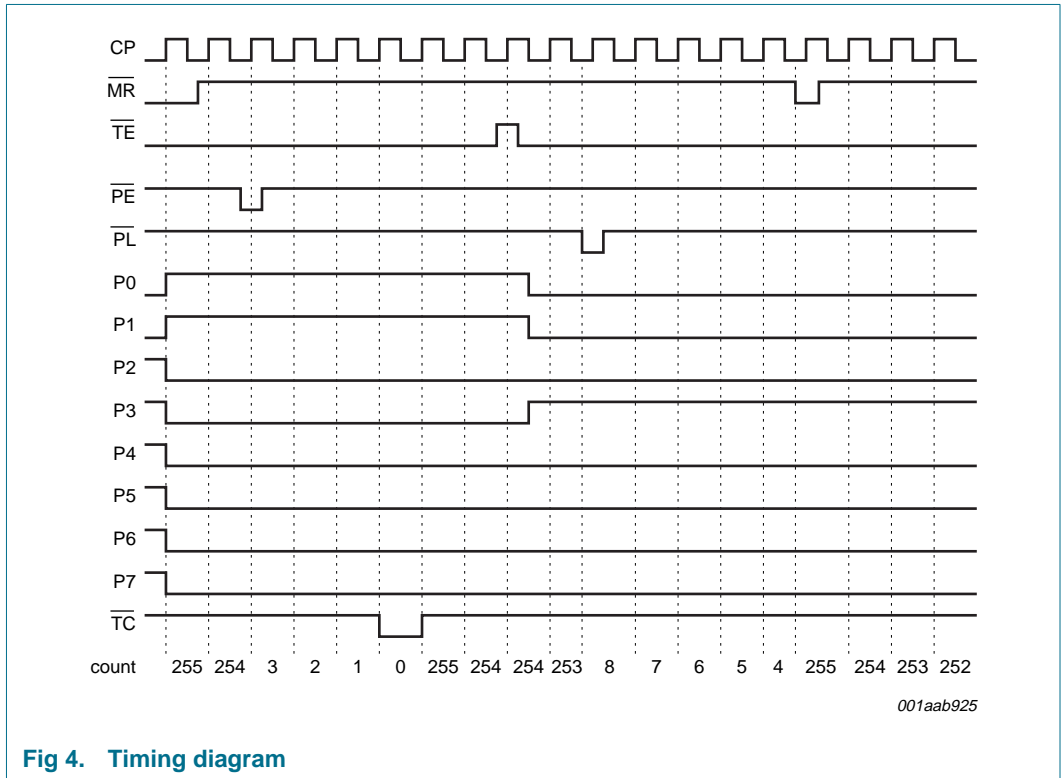

Fig 4. Timing diagram

7. Pinning information

7.1 Pinning

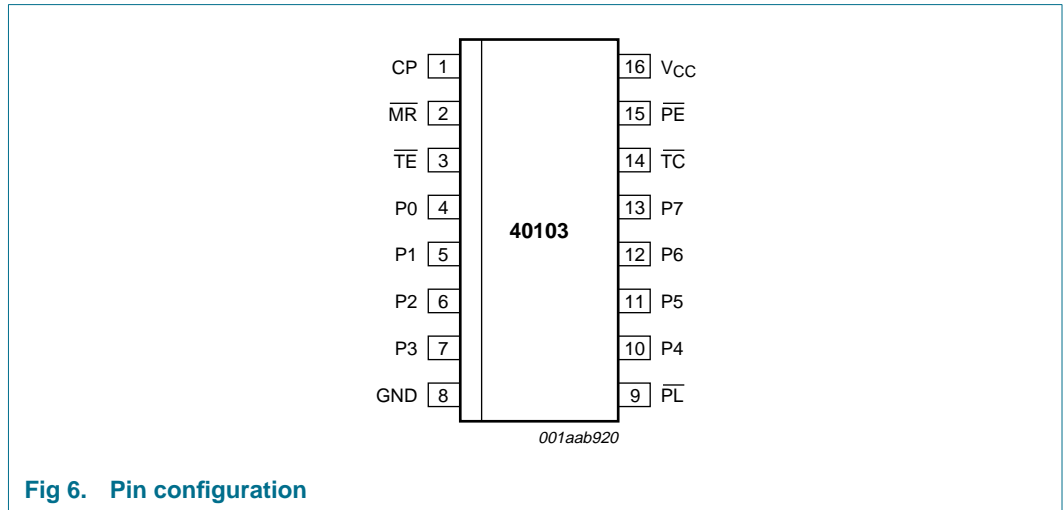

Fig 6. Pin configuration

7.2 Pin description

Table 3: Pin description

Symbol	Pin	Description
CP	1	clock input (LOW-to-HIGH, edge-triggered)
$\overline{\text{MR}}$	2	asynchronous master reset input (active LOW)
$\overline{\text{TE}}$	3	terminal enable input (active LOW)
P0	4	jam input 0
P1	5	jam input 1
P2	6	jam input 2
P3	7	jam input 3
GND	8	ground (0 V)
$\overline{\text{PL}}$	9	asynchronous preset enable input (active LOW)
P4	10	jam input 4
P5	11	jam input 5
P6	12	jam input 6
P7	13	jam input 7
$\overline{\text{TC}}$	14	terminal count output (active LOW)
$\overline{\text{PE}}$	15	synchronous preset enable input (active LOW)
V _{CC}	16	positive supply voltage

8. Functional description

8.1 Function table

Table 4: Function table ^[1]

Control inputs				Preset mode	Action ^[2]
MR	PL	PE	TE		
L	X	X	X	asynchronous	clear to maximum count
H	L	X	X	asynchronous	preset asynchronously
		H	X	synchronous	preset on next LOW-to HIGH clock transition
	H	L	L	synchronous	count down
		H	H	synchronous	inhibit counter

[1] H = HIGH voltage level;
L = LOW voltage level;
X = don't care.

[2] Clock connected to CP.
Synchronous operation: changes occur on the LOW-to-HIGH CP transition.
Jam inputs: MSD = P7, LSD = P0.

9. Limiting values

Table 5: Limiting values

In accordance with the Absolute Maximum Rating System (IEC 60134). Voltages are referenced to GND (ground = 0 V).

Symbol	Parameter	Conditions	Min	Max	Unit
V_{CC}	supply voltage		-0.5	+7	V
I_{IK}	input diode current	$V_I < -0.5\text{ V}$ or $V_I > V_{CC} + 0.5\text{ V}$	-	± 20	mA
I_{OK}	output diode current	$V_O < -0.5\text{ V}$ or $V_O > V_{CC} + 0.5\text{ V}$	-	± 20	mA
I_O	output source or sink current	$V_O = -0.5\text{ V}$ to $V_{CC} + 0.5\text{ V}$	-	± 25	mA
I_{CC}, I_{GND}	V_{CC} or GND current		-	± 50	mA
T_{stg}	storage temperature		-65	+150	°C
P_{tot}	power dissipation				
	DIP16 package		^[1] -	750	mW
	SO16, SSOP16 and TSSOP16 packages		^[2] -	500	mW

[1] Above 70 °C: P_{tot} derates linearly with 12 mW/K.

[2] Above 70 °C: P_{tot} derates linearly with 8 mW/K.

10. Recommended operating conditions

Table 6: Recommended operating conditions

Symbol	Parameter	Conditions	Min	Typ	Max	Unit
V_{CC}	supply voltage		2.0	5.0	6.0	V
V_I	input voltage		0	-	V_{CC}	V
V_O	output voltage		0	-	V_{CC}	V
t_r, t_f	input rise and fall times	$V_{CC} = 2.0\text{ V}$	-	-	1000	ns
		$V_{CC} = 4.5\text{ V}$	-	6.0	500	ns
		$V_{CC} = 6.0\text{ V}$	-	-	400	ns
T_{amb}	ambient temperature		-40	-	+125	°C

11. Static characteristics

Table 7: Static characteristics

At recommended operating conditions; voltages are referenced to GND (ground = 0 V).

Symbol	Parameter	Conditions	Min	Typ	Max	Unit
$T_{amb} = 25\text{ °C}$						
V_{IH}	HIGH-level input voltage	$V_{CC} = 2.0\text{ V}$	1.5	1.2	-	V
		$V_{CC} = 4.5\text{ V}$	3.15	2.4	-	V
		$V_{CC} = 6.0\text{ V}$	4.2	3.2	-	V
V_{IL}	LOW-level input voltage	$V_{CC} = 2.0\text{ V}$	-	0.8	0.5	V
		$V_{CC} = 4.5\text{ V}$	-	2.1	1.35	V
		$V_{CC} = 6.0\text{ V}$	-	2.8	1.8	V
V_{OH}	HIGH-level output voltage	$V_I = V_{IH}$ or V_{IL}				
		$I_O = -20\text{ }\mu\text{A}; V_{CC} = 2.0\text{ V}$	1.9	2.0	-	V
		$I_O = -20\text{ }\mu\text{A}; V_{CC} = 4.5\text{ V}$	4.4	4.5	-	V
		$I_O = -20\text{ }\mu\text{A}; V_{CC} = 6.0\text{ V}$	5.9	6.0	-	V
		$I_O = -4\text{ mA}; V_{CC} = 4.5\text{ V}$	3.98	4.32	-	V
V_{OL}	LOW-level output voltage	$V_I = V_{IH}$ or V_{IL}				
		$I_O = 20\text{ }\mu\text{A}; V_{CC} = 2.0\text{ V}$	-	0	0.1	V
		$I_O = 20\text{ }\mu\text{A}; V_{CC} = 4.5\text{ V}$	-	0	0.1	V
		$I_O = 20\text{ }\mu\text{A}; V_{CC} = 6.0\text{ V}$	-	0	0.1	V
		$I_O = 4\text{ mA}; V_{CC} = 4.5\text{ V}$	-	0.15	0.26	V
		$I_O = 5.2\text{ mA}; V_{CC} = 6.0\text{ V}$	-	0.16	0.26	V
I_{LI}	input leakage current	$V_I = V_{CC}$ or GND; $V_{CC} = 6.0\text{ V}$	-	-	± 0.1	μA
I_{CC}	quiescent supply current	$V_I = V_{CC}$ or GND; $I_O = 0\text{ A}; V_{CC} = 6.0\text{ V}$	-	-	8.0	μA
C_I	input capacitance		-	3.5	-	pF

Table 7: Static characteristics ...continued

At recommended operating conditions; voltages are referenced to GND (ground = 0 V).

Symbol	Parameter	Conditions	Min	Typ	Max	Unit
T_{amb} = -40 °C to +85 °C						
V _{IH}	HIGH-level input voltage	V _{CC} = 2.0 V	1.5	-	-	V
		V _{CC} = 4.5 V	3.15	-	-	V
		V _{CC} = 6.0 V	4.2	-	-	V
V _{IL}	LOW-level input voltage	V _{CC} = 2.0 V	-	-	0.5	V
		V _{CC} = 4.5 V	-	-	1.35	V
		V _{CC} = 6.0 V	-	-	1.8	V
V _{OH}	HIGH-level output voltage	V _I = V _{IH} or V _{IL}				
		I _O = -20 μA; V _{CC} = 2.0 V	1.9	-	-	V
		I _O = -20 μA; V _{CC} = 4.5 V	4.4	-	-	V
		I _O = -20 μA; V _{CC} = 6.0 V	5.9	-	-	V
		I _O = -4 mA; V _{CC} = 4.5 V	3.84	-	-	V
V _{OL}	LOW-level output voltage	V _I = V _{IH} or V _{IL}				
		I _O = 20 μA; V _{CC} = 2.0 V	-	-	0.1	V
		I _O = 20 μA; V _{CC} = 4.5 V	-	-	0.1	V
		I _O = 20 μA; V _{CC} = 6.0 V	-	-	0.1	V
		I _O = 4 mA; V _{CC} = 4.5 V	-	-	0.33	V
I _{LI}	input leakage current	V _I = V _{CC} or GND; V _{CC} = 6.0 V	-	-	±1.0	μA
		V _I = V _{CC} or GND; I _O = 0 A; V _{CC} = 6.0 V	-	-	80	μA
T_{amb} = -40 °C to +125 °C						
V _{IH}	HIGH-level input voltage	V _{CC} = 2.0 V	1.5	-	-	V
		V _{CC} = 4.5 V	3.15	-	-	V
		V _{CC} = 6.0 V	4.2	-	-	V
V _{IL}	LOW-level input voltage	V _{CC} = 2.0 V	-	-	0.5	V
		V _{CC} = 4.5 V	-	-	1.35	V
		V _{CC} = 6.0 V	-	-	1.8	V
V _{OH}	HIGH-level output voltage	V _I = V _{IH} or V _{IL}				
		I _O = -20 μA; V _{CC} = 2.0 V	1.9	-	-	V
		I _O = -20 μA; V _{CC} = 4.5 V	4.4	-	-	V
		I _O = -20 μA; V _{CC} = 6.0 V	5.9	-	-	V
		I _O = -4 mA; V _{CC} = 4.5 V	3.7	-	-	V
I _{LI}	input leakage current	V _I = V _{CC} or GND; V _{CC} = 6.0 V	-	-	±1.0	μA
		V _I = V _{CC} or GND; I _O = 0 A; V _{CC} = 6.0 V	-	-	80	μA

Table 7: Static characteristics ...continued

At recommended operating conditions; voltages are referenced to GND (ground = 0 V).

Symbol	Parameter	Conditions	Min	Typ	Max	Unit
V _{OL}	LOW-level output voltage	V _I = V _{IH} or V _{IL}				
		I _O = 20 μA; V _{CC} = 2.0 V	-	-	0.1	V
		I _O = 20 μA; V _{CC} = 4.5 V	-	-	0.1	V
		I _O = 20 μA; V _{CC} = 6.0 V	-	-	0.1	V
		I _O = 4 mA; V _{CC} = 4.5 V	-	-	0.4	V
		I _O = 5.2 mA; V _{CC} = 6.0 V	-	-	0.4	V
I _{LI}	input leakage current	V _I = V _{CC} or GND; V _{CC} = 6.0 V	-	-	±1.0	μA
I _{CC}	quiescent supply current	V _I = V _{CC} or GND; I _O = 0 A; V _{CC} = 6.0 V	-	-	160	μA

12. Dynamic characteristics

Table 8: Dynamic characteristics

GND = 0 V; t_r = t_f = 6 ns; C_L = 50 pF; see [Figure 13](#).

Symbol	Parameter	Conditions	Min	Typ	Max	Unit	
T_{amb} = 25 °C							
t _{PHL} , t _{PLH}	propagation delay CP to \overline{TC}	see Figure 7					
		V _{CC} = 2.0 V	-	96	300	ns	
		V _{CC} = 4.5 V	-	35	60	ns	
		V _{CC} = 6.0 V	-	28	51	ns	
		V _{CC} = 5.0 V; C _L = 15 pF	-	30	-	ns	
	propagation delay \overline{TE} to \overline{TC}	see Figure 8					
		V _{CC} = 2.0 V	-	50	175	ns	
		V _{CC} = 4.5 V	-	18	35	ns	
		V _{CC} = 6.0 V	-	14	30	ns	
	propagation delay \overline{PL} to \overline{TC}	see Figure 9					
		V _{CC} = 2.0 V	-	102	315	ns	
		V _{CC} = 4.5 V	-	37	63	ns	
		V _{CC} = 6.0 V	-	30	53	ns	
t _{PHL}	propagation delay \overline{MR} to \overline{TC}	see Figure 9					
		V _{CC} = 2.0 V	-	83	275	ns	
		V _{CC} = 4.5 V	-	30	55	ns	
		V _{CC} = 6.0 V	-	24	47	ns	
t _{THL} , t _{TLH}	output transition time	see Figure 8					
		V _{CC} = 2.0 V	-	19	75	ns	
		V _{CC} = 4.5 V	-	7	15	ns	
		V _{CC} = 6.0 V	-	6	13	ns	

Table 8: Dynamic characteristics ...continued
GND = 0 V; $t_r = t_f = 6$ ns; $C_L = 50$ pF; see [Figure 13](#).

Symbol	Parameter	Conditions	Min	Typ	Max	Unit	
t_{W}	CP clock pulse width HIGH or LOW	see Figure 7					
		$V_{CC} = 2.0$ V	165	22	-	ns	
		$V_{CC} = 4.5$ V	33	8	-	ns	
			$V_{CC} = 6.0$ V	28	6	-	ns
	MR master reset pulse width LOW	see Figure 9					
		$V_{CC} = 2.0$ V	125	39	-	ns	
		$V_{CC} = 4.5$ V	25	14	-	ns	
			$V_{CC} = 6.0$ V	21	11	-	ns
	PL preset enable pulse width LOW	see Figure 9					
$V_{CC} = 2.0$ V		125	33	-	ns		
$V_{CC} = 4.5$ V		25	12	-	ns		
		$V_{CC} = 6.0$ V	21	10	-	ns	
t_{rem}	removal time MR to CP, PL to CP	see Figure 10					
		$V_{CC} = 2.0$ V	50	14	-	ns	
		$V_{CC} = 4.5$ V	10	5	-	ns	
		$V_{CC} = 6.0$ V	9	4	-	ns	
t_{su}	set-up time \overline{PE} to CP	see Figure 11					
		$V_{CC} = 2.0$ V	75	22	-	ns	
		$V_{CC} = 4.5$ V	15	8	-	ns	
			$V_{CC} = 6.0$ V	13	6	-	ns
	set-up time \overline{TE} to CP	see Figure 12					
		$V_{CC} = 2.0$ V	150	44	-	ns	
		$V_{CC} = 4.5$ V	30	16	-	ns	
			$V_{CC} = 6.0$ V	26	13	-	ns
	set-up time Pn to CP	see Figure 11					
		$V_{CC} = 2.0$ V	75	22	-	ns	
		$V_{CC} = 4.5$ V	15	8	-	ns	
			$V_{CC} = 6.0$ V	13	6	-	ns
t_h	hold time \overline{PE} to CP	see Figure 11					
		$V_{CC} = 2.0$ V	0	-14	-	ns	
		$V_{CC} = 4.5$ V	0	-5	-	ns	
			$V_{CC} = 6.0$ V	0	-4	-	ns
	hold time \overline{TE} to CP	see Figure 12					
		$V_{CC} = 2.0$ V	0	-30	-	ns	
		$V_{CC} = 4.5$ V	0	-11	-	ns	
			$V_{CC} = 6.0$ V	0	-9	-	ns
	hold time Pn to CP	see Figure 11					
$V_{CC} = 2.0$ V		0	-17	-	ns		
$V_{CC} = 4.5$ V		0	-6	-	ns		
		$V_{CC} = 6.0$ V	0	-5	-	ns	

Table 8: Dynamic characteristics ...continued
 $GND = 0\text{ V}$; $t_r = t_f = 6\text{ ns}$; $C_L = 50\text{ pF}$; see [Figure 13](#).

Symbol	Parameter	Conditions	Min	Typ	Max	Unit	
f_{\max}	maximum clock frequency	see Figure 7					
		$V_{CC} = 2.0\text{ V}$	3.0	10	-	MHz	
		$V_{CC} = 4.5\text{ V}$	15	29	-	MHz	
		$V_{CC} = 6.0\text{ V}$	18	35	-	MHz	
		$V_{CC} = 5.0\text{ V}$; $C_L = 15\text{ pF}$	-	32	-	MHz	
C_{PD}	power dissipation capacitance	$V_I = GND$ to V_{CC}	[1]	-	24	pF	
$T_{\text{amb}} = -40\text{ }^{\circ}\text{C}$ to $+85\text{ }^{\circ}\text{C}$							
t_{PHL} , t_{PLH}	propagation delay CP to \overline{TC}	see Figure 7					
		$V_{CC} = 2.0\text{ V}$	-	-	375	ns	
		$V_{CC} = 4.5\text{ V}$	-	-	75	ns	
			$V_{CC} = 6.0\text{ V}$	-	-	64	ns
	propagation delay \overline{TE} to \overline{TC}	see Figure 8					
		$V_{CC} = 2.0\text{ V}$	-	-	220	ns	
		$V_{CC} = 4.5\text{ V}$	-	-	44	ns	
			$V_{CC} = 6.0\text{ V}$	-	-	37	ns
	propagation delay \overline{PL} to \overline{TC}	see Figure 9					
		$V_{CC} = 2.0\text{ V}$	-	-	395	ns	
		$V_{CC} = 4.5\text{ V}$	-	-	79	ns	
			$V_{CC} = 6.0\text{ V}$	-	-	40	ns
t_{PHL}	propagation delay \overline{MR} to \overline{TC}	see Figure 9					
		$V_{CC} = 2.0\text{ V}$	-	-	345	ns	
		$V_{CC} = 4.5\text{ V}$	-	-	69	ns	
		$V_{CC} = 6.0\text{ V}$	-	-	59	ns	
t_{THL} , t_{TLH}	output transition time	see Figure 8					
		$V_{CC} = 2.0\text{ V}$	-	-	95	ns	
		$V_{CC} = 4.5\text{ V}$	-	-	19	ns	
		$V_{CC} = 6.0\text{ V}$	-	-	16	ns	
t_w	CP clock pulse width HIGH or LOW	see Figure 7					
		$V_{CC} = 2.0\text{ V}$	205	-	-	ns	
		$V_{CC} = 4.5\text{ V}$	41	-	-	ns	
			$V_{CC} = 6.0\text{ V}$	35	-	-	ns
	\overline{MR} master reset pulse width LOW	see Figure 9					
		$V_{CC} = 2.0\text{ V}$	155	-	-	ns	
		$V_{CC} = 4.5\text{ V}$	31	-	-	ns	
			$V_{CC} = 6.0\text{ V}$	26	-	-	ns
	\overline{PL} preset enable pulse width LOW	see Figure 9					
		$V_{CC} = 2.0\text{ V}$	155	-	-	ns	
		$V_{CC} = 4.5\text{ V}$	31	-	-	ns	
			$V_{CC} = 6.0\text{ V}$	26	-	-	ns

Table 8: Dynamic characteristics ...continued
GND = 0 V; $t_r = t_f = 6$ ns; $C_L = 50$ pF; see [Figure 13](#).

Symbol	Parameter	Conditions	Min	Typ	Max	Unit	
t_{rem}	removal time \overline{MR} to CP, \overline{PL} to CP	see Figure 10					
		$V_{CC} = 2.0$ V	65	-	-	ns	
		$V_{CC} = 4.5$ V	13	-	-	ns	
		$V_{CC} = 6.0$ V	11	-	-	ns	
t_{su}	set-up time \overline{PE} to CP	see Figure 11					
		$V_{CC} = 2.0$ V	95	-	-	ns	
		$V_{CC} = 4.5$ V	19	-	-	ns	
			$V_{CC} = 6.0$ V	16	-	-	ns
	set-up time \overline{TE} to CP	see Figure 12					
		$V_{CC} = 2.0$ V	190	-	-	ns	
		$V_{CC} = 4.5$ V	38	-	-	ns	
			$V_{CC} = 6.0$ V	33	-	-	ns
	set-up time Pn to CP	see Figure 11					
$V_{CC} = 2.0$ V		95	-	-	ns		
$V_{CC} = 4.5$ V		19	-	-	ns		
		$V_{CC} = 6.0$ V	16	-	-	ns	
t_h	hold time \overline{PE} to CP	see Figure 11					
		$V_{CC} = 2.0$ V	0	-	-	ns	
		$V_{CC} = 4.5$ V	0	-	-	ns	
			$V_{CC} = 6.0$ V	0	-	-	ns
	hold time \overline{TE} to CP	see Figure 12					
		$V_{CC} = 2.0$ V	0	-	-	ns	
		$V_{CC} = 4.5$ V	0	-	-	ns	
			$V_{CC} = 6.0$ V	0	-	-	ns
	hold time Pn to CP	see Figure 11					
$V_{CC} = 2.0$ V		0	-	-	ns		
$V_{CC} = 4.5$ V		0	-	-	ns		
		$V_{CC} = 6.0$ V	0	-	-	ns	
f_{max}	maximum clock frequency	see Figure 7					
		$V_{CC} = 2.0$ V	2.4	-	-	MHz	
		$V_{CC} = 4.5$ V	12	-	-	MHz	
		$V_{CC} = 6.0$ V	14	-	-	MHz	

Table 8: Dynamic characteristics ...continued
 $GND = 0\text{ V}$; $t_r = t_f = 6\text{ ns}$; $C_L = 50\text{ pF}$; see [Figure 13](#).

Symbol	Parameter	Conditions	Min	Typ	Max	Unit	
$T_{\text{amb}} = -40\text{ °C to }+125\text{ °C}$							
$t_{\text{PHL}}/t_{\text{PLH}}$	propagation delay CP to $\overline{\text{TC}}$	see Figure 7					
		$V_{\text{CC}} = 2.0\text{ V}$	-	-	450	ns	
		$V_{\text{CC}} = 4.5\text{ V}$	-	-	90	ns	
			$V_{\text{CC}} = 6.0\text{ V}$	-	-	77	ns
	propagation delay $\overline{\text{TE}}$ to $\overline{\text{TC}}$	see Figure 8					
		$V_{\text{CC}} = 2.0\text{ V}$	-	-	265	ns	
		$V_{\text{CC}} = 4.5\text{ V}$	-	-	53	ns	
			$V_{\text{CC}} = 6.0\text{ V}$	-	-	45	ns
	propagation delay $\overline{\text{PL}}$ to $\overline{\text{TC}}$	see Figure 9					
$V_{\text{CC}} = 2.0\text{ V}$		-	-	475	ns		
$V_{\text{CC}} = 4.5\text{ V}$		-	-	95	ns		
		$V_{\text{CC}} = 6.0\text{ V}$	-	-	81	ns	
t_{PHL}	propagation delay $\overline{\text{MR}}$ to $\overline{\text{TC}}$	see Figure 9					
		$V_{\text{CC}} = 2.0\text{ V}$	-	-	415	ns	
		$V_{\text{CC}} = 4.5\text{ V}$	-	-	83	ns	
		$V_{\text{CC}} = 6.0\text{ V}$	-	-	71	ns	
$t_{\text{THL}}/t_{\text{TLH}}$	output transition time	see Figure 8					
		$V_{\text{CC}} = 2.0\text{ V}$	-	-	110	ns	
		$V_{\text{CC}} = 4.5\text{ V}$	-	-	22	ns	
		$V_{\text{CC}} = 6.0\text{ V}$	-	-	19	ns	
t_w	CP clock pulse width HIGH or LOW	see Figure 7					
		$V_{\text{CC}} = 2.0\text{ V}$	250	-	-	ns	
		$V_{\text{CC}} = 4.5\text{ V}$	50	-	-	ns	
			$V_{\text{CC}} = 6.0\text{ V}$	43	-	-	ns
	$\overline{\text{MR}}$ master reset pulse width LOW	see Figure 9					
		$V_{\text{CC}} = 2.0\text{ V}$	190	-	-	ns	
		$V_{\text{CC}} = 4.5\text{ V}$	38	-	-	ns	
			$V_{\text{CC}} = 6.0\text{ V}$	32	-	-	ns
	$\overline{\text{PL}}$ preset enable pulse width LOW	see Figure 9					
$V_{\text{CC}} = 2.0\text{ V}$		190	-	-	ns		
$V_{\text{CC}} = 4.5\text{ V}$		38	-	-	ns		
		$V_{\text{CC}} = 6.0\text{ V}$	32	-	-	ns	
t_{rem}	removal time $\overline{\text{MR}}$ to CP, $\overline{\text{PL}}$ to CP	see Figure 10					
		$V_{\text{CC}} = 2.0\text{ V}$	75	-	-	ns	
		$V_{\text{CC}} = 4.5\text{ V}$	15	-	-	ns	
		$V_{\text{CC}} = 6.0\text{ V}$	13	-	-	ns	

Table 8: Dynamic characteristics ...continued
GND = 0 V; $t_r = t_f = 6$ ns; $C_L = 50$ pF; see [Figure 13](#).

Symbol	Parameter	Conditions	Min	Typ	Max	Unit
t_{su}	set-up time \overline{PE} to CP	see Figure 11				
		$V_{CC} = 2.0$ V	110	-	-	ns
		$V_{CC} = 4.5$ V	22	-	-	ns
	set-up time \overline{TE} to CP	$V_{CC} = 6.0$ V	19	-	-	ns
		see Figure 12				
		$V_{CC} = 2.0$ V	225	-	-	ns
	set-up time Pn to CP	$V_{CC} = 4.5$ V	45	-	-	ns
		$V_{CC} = 6.0$ V	38	-	-	ns
		see Figure 11				
t_h	hold time \overline{PE} to CP	$V_{CC} = 2.0$ V	110	-	-	ns
		$V_{CC} = 4.5$ V	22	-	-	ns
		$V_{CC} = 6.0$ V	19	-	-	ns
	hold time \overline{TE} to CP	see Figure 11				
		$V_{CC} = 2.0$ V	0	-	-	ns
		$V_{CC} = 4.5$ V	0	-	-	ns
	hold time Pn to CP	$V_{CC} = 6.0$ V	0	-	-	ns
		see Figure 12				
		$V_{CC} = 2.0$ V	0	-	-	ns
hold time Pn to CP	$V_{CC} = 4.5$ V	0	-	-	ns	
	$V_{CC} = 6.0$ V	0	-	-	ns	
	see Figure 11					
f_{max}	maximum clock frequency	see Figure 7				
		$V_{CC} = 2.0$ V	2.0	-	-	MHz
		$V_{CC} = 4.5$ V	10	-	-	MHz
		$V_{CC} = 6.0$ V	12	-	-	MHz

[1] C_{PD} is used to determine the dynamic power dissipation (P_D in μ W).
 $P_D = C_{PD} \times V_{CC}^2 \times f_i \times N + \sum(C_L \times V_{CC}^2 \times f_o)$ where:
 f_i = input frequency in MHz;
 f_o = output frequency in MHz;
 C_L = output load capacitance in pF;
 V_{CC} = supply voltage in V;
 N = number of inputs switching;
 $\sum(C_L \times V_{CC}^2 \times f_o)$ = sum of outputs.

13. Waveforms

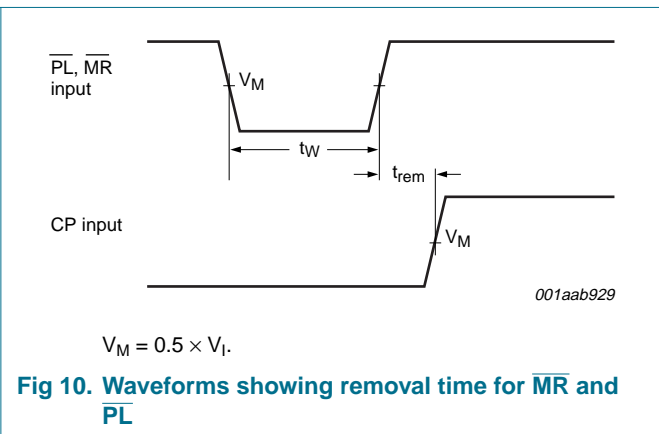
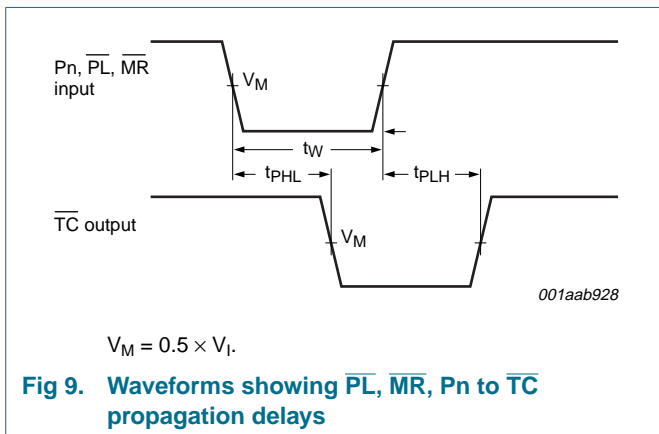
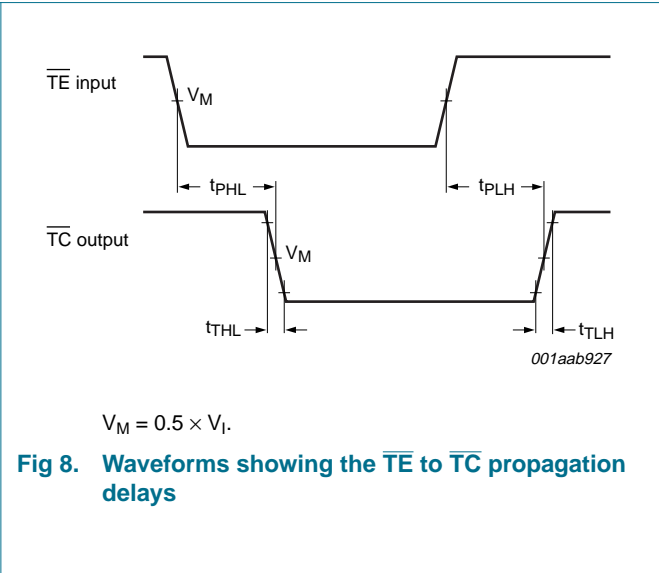
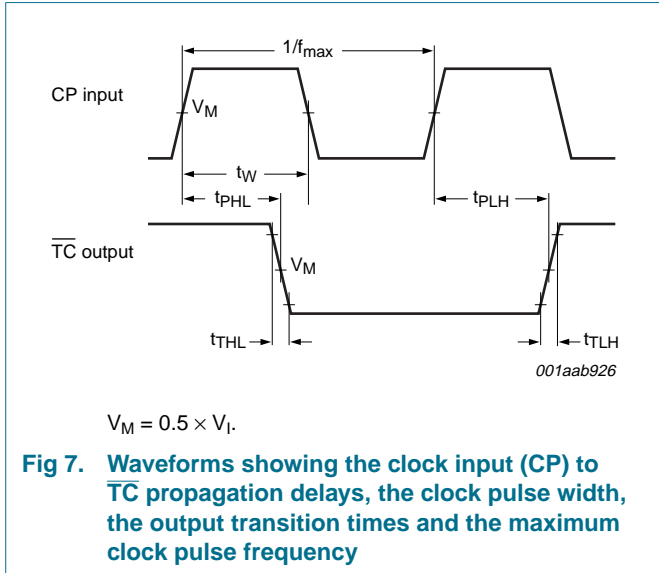

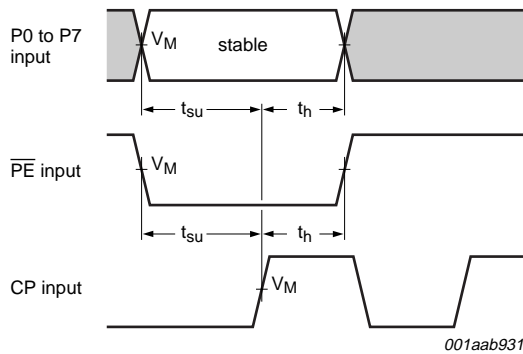

The shaded areas indicate when the input is permitted to change for predictable output performance.
 $V_M = 0.5 \times V_I$.

Fig 11. Waveforms showing hold and set-up times for Pn, PE to CP

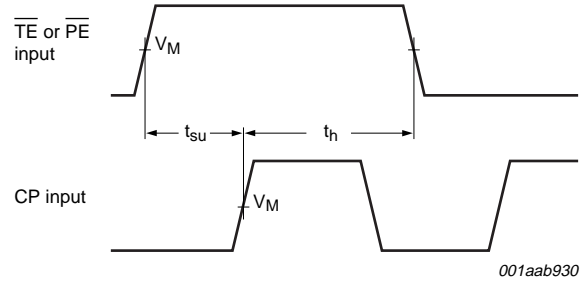

$V_M = 0.5 \times V_I$.

Fig 12. Waveforms showing hold and set-up times for MR or PE to CP

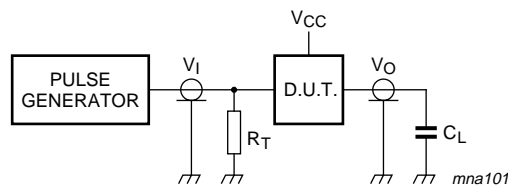

Test data is given in [Table 9](#).

Definitions for test circuit:

R_T = Termination resistance should be equal to output impedance Z_o of the pulse generator.

C_L = Load capacitance including jig and probe capacitance.

Fig 13. Load circuitry for switching times

Table 9: Test data

Supply	Input	Load
V_{CC}	V_I t_r, t_f	C_L
2.0 V	V_{CC} 6 ns	50 pF
4.5 V	V_{CC} 6 ns	50 pF
6.0 V	V_{CC} 6 ns	50 pF
5.0 V	V_{CC} 6 ns	15 pF

14. Application information

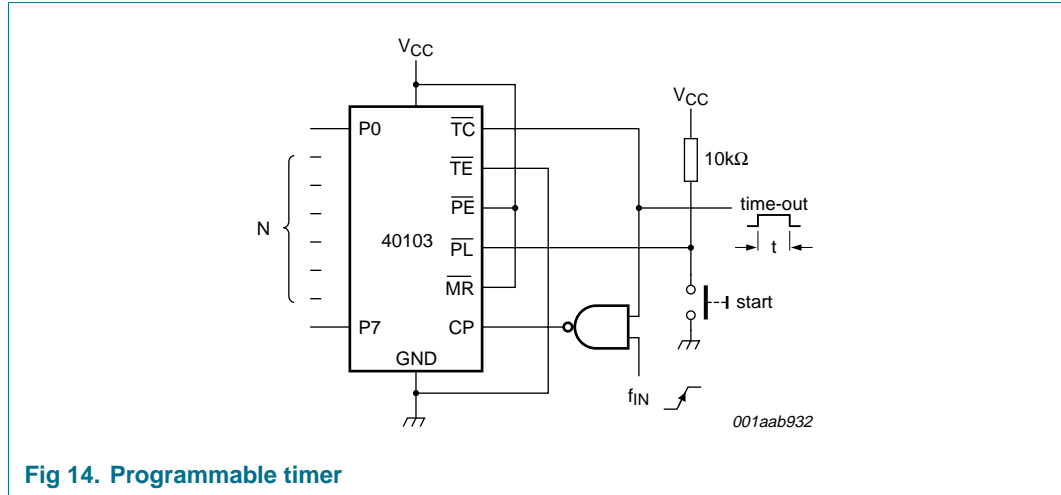

Fig 14. Programmable timer

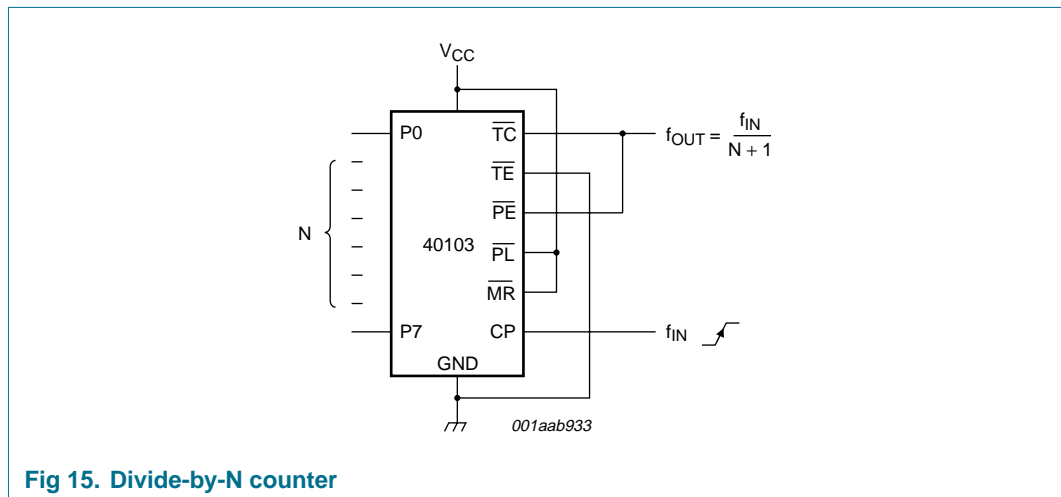

Fig 15. Divide-by-N counter

15. Package outline

DIP16: plastic dual in-line package; 16 leads (300 mil)

SOT38-4

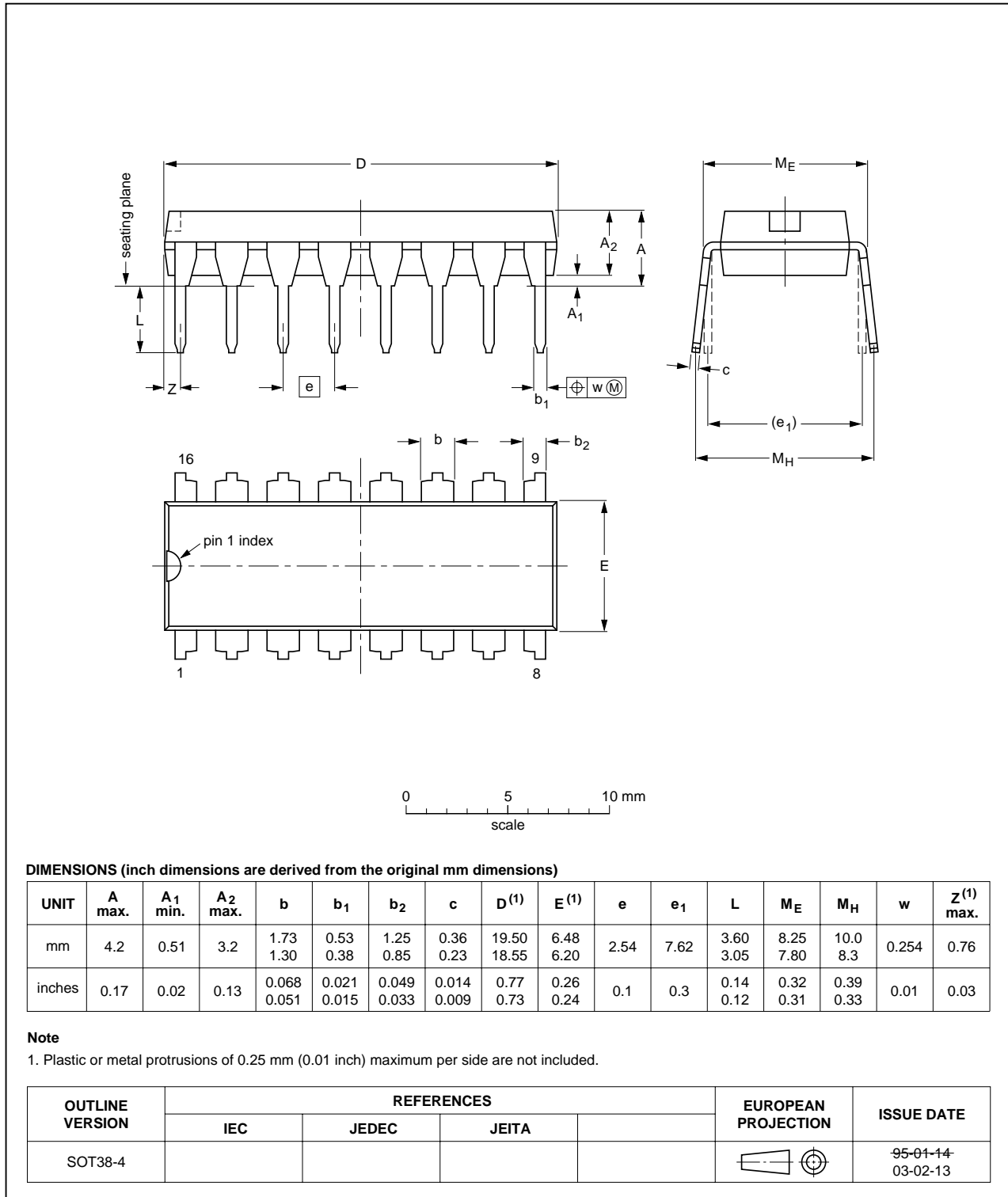

Fig 16. Package outline SOT38-4 (DIP16)

SO16: plastic small outline package; 16 leads; body width 3.9 mm

SOT109-1

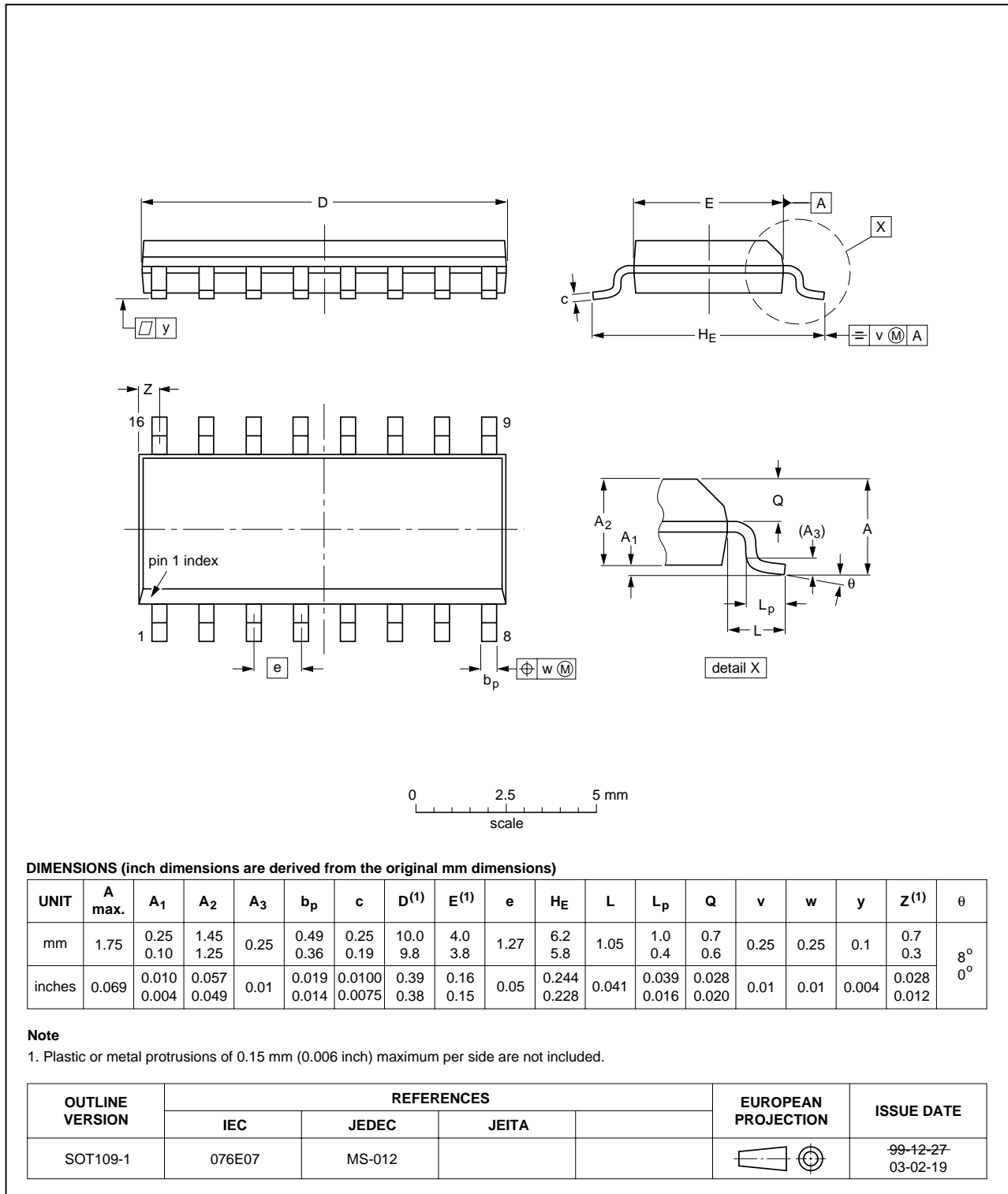

Fig 17. Package outline SOT109-1 (SO16)

SSOP16: plastic shrink small outline package; 16 leads; body width 5.3 mm

SOT338-1

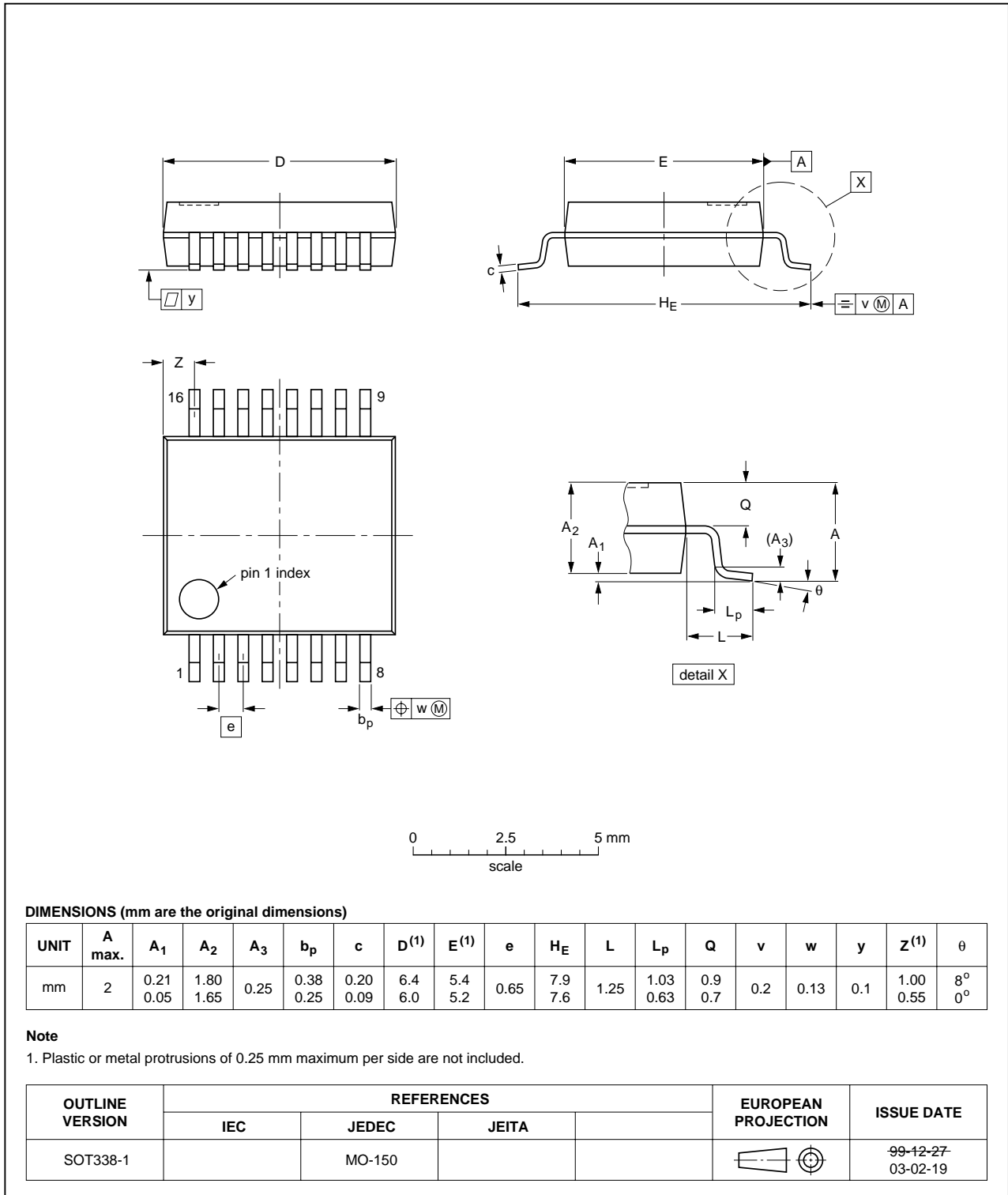

Fig 18. Package outline SOT338-1 (SSOP16)

TSSOP16: plastic thin shrink small outline package; 16 leads; body width 4.4 mm

SOT403-1

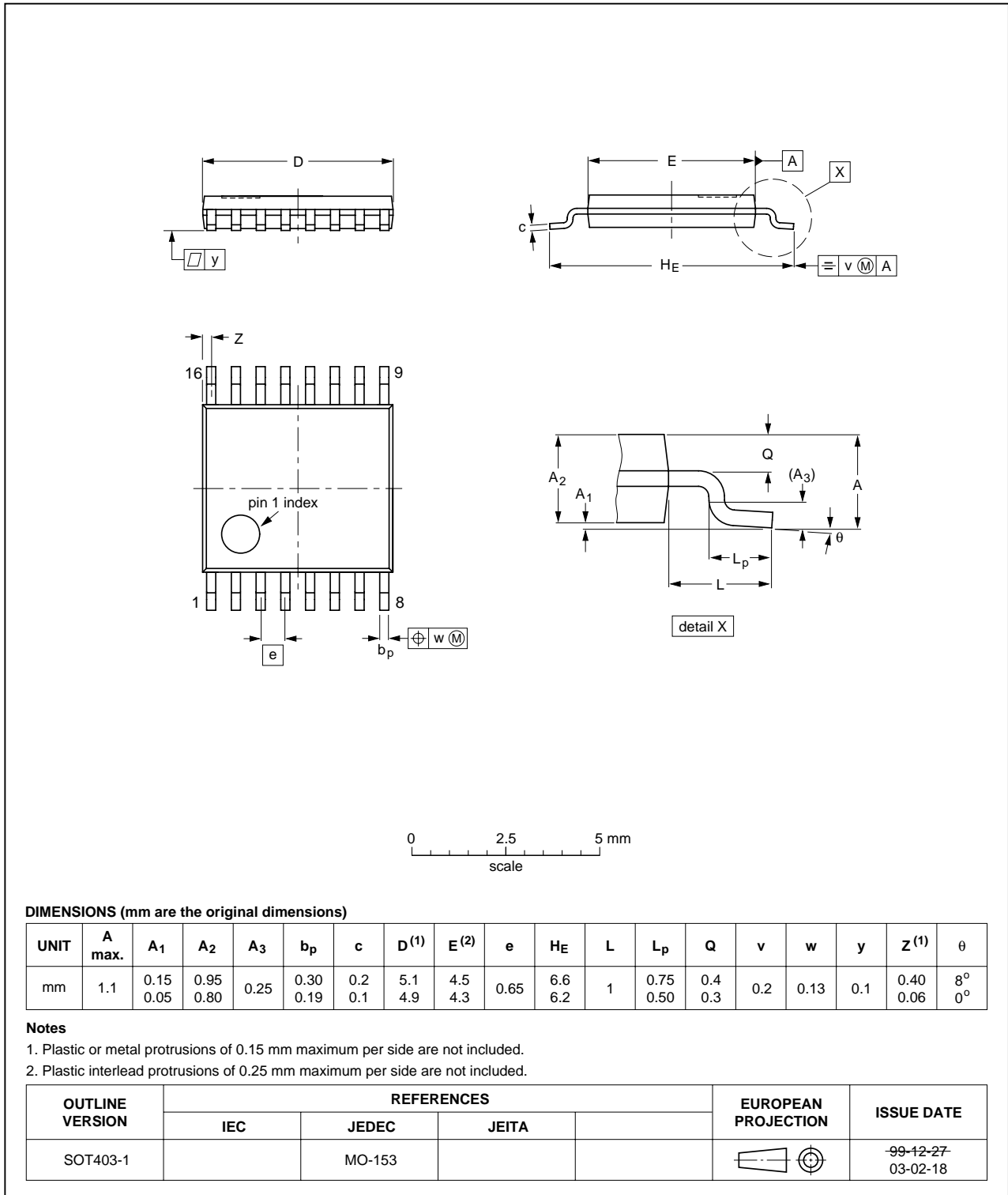

Fig 19. Package outline SOT403-1 (TSSOP16)

16. Revision history

Table 10: Revision history

Document ID	Release date	Data sheet status	Change notice	Doc. number	Supersedes
74HC40103_3	20041112	Product data sheet	-	9397 750 13812	74HC_HCT40103_CNV_2
Modifications:			<ul style="list-style-type: none">• The format of this data sheet has been redesigned to comply with the current presentation and information standard of Philips Semiconductors.• Removed type number 74HCT40103.• Inserted family specification.		
74HC_HCT40103_CNV_2	19970918	Product specification	-	-	74HC_HCT40103_1
74HC_HCT40103_1	19901201	Product specification	-	-	-

17. Data sheet status

Level	Data sheet status ^[1]	Product status ^[2] ^[3]	Definition
I	Objective data	Development	This data sheet contains data from the objective specification for product development. Philips Semiconductors reserves the right to change the specification in any manner without notice.
II	Preliminary data	Qualification	This data sheet contains data from the preliminary specification. Supplementary data will be published at a later date. Philips Semiconductors reserves the right to change the specification without notice, in order to improve the design and supply the best possible product.
III	Product data	Production	This data sheet contains data from the product specification. Philips Semiconductors reserves the right to make changes at any time in order to improve the design, manufacturing and supply. Relevant changes will be communicated via a Customer Product/Process Change Notification (CPCN).

[1] Please consult the most recently issued data sheet before initiating or completing a design.

[2] The product status of the device(s) described in this data sheet may have changed since this data sheet was published. The latest information is available on the Internet at URL <http://www.semiconductors.philips.com>.

[3] For data sheets describing multiple type numbers, the highest-level product status determines the data sheet status.

18. Definitions

Short-form specification — The data in a short-form specification is extracted from a full data sheet with the same type number and title. For detailed information see the relevant data sheet or data handbook.

Limiting values definition — Limiting values given are in accordance with the Absolute Maximum Rating System (IEC 60134). Stress above one or more of the limiting values may cause permanent damage to the device. These are stress ratings only and operation of the device at these or at any other conditions above those given in the Characteristics sections of the specification is not implied. Exposure to limiting values for extended periods may affect device reliability.

Application information — Applications that are described herein for any of these products are for illustrative purposes only. Philips Semiconductors make no representation or warranty that such applications will be suitable for the specified use without further testing or modification.

19. Disclaimers

Life support — These products are not designed for use in life support appliances, devices, or systems where malfunction of these products can reasonably be expected to result in personal injury. Philips Semiconductors customers using or selling these products for use in such applications do so at their own risk and agree to fully indemnify Philips Semiconductors for any damages resulting from such application.

Right to make changes — Philips Semiconductors reserves the right to make changes in the products - including circuits, standard cells, and/or software - described or contained herein in order to improve design and/or performance. When the product is in full production (status 'Production'), relevant changes will be communicated via a Customer Product/Process Change Notification (CPCN). Philips Semiconductors assumes no responsibility or liability for the use of any of these products, conveys no license or title under any patent, copyright, or mask work right to these products, and makes no representations or warranties that these products are free from patent, copyright, or mask work right infringement, unless otherwise specified.

20. Contact information

For additional information, please visit: <http://www.semiconductors.philips.com>

For sales office addresses, send an email to: sales.addresses@www.semiconductors.philips.com

21. Contents

1	General description	1
2	Features	2
3	Applications	2
4	Quick reference data	2
5	Ordering information	3
6	Functional diagram	3
7	Pinning information	6
7.1	Pinning	6
7.2	Pin description	6
8	Functional description	7
8.1	Function table	7
9	Limiting values	7
10	Recommended operating conditions	8
11	Static characteristics	8
12	Dynamic characteristics	10
13	Waveforms	16
14	Application information	18
15	Package outline	19
16	Revision history	23
17	Data sheet status	24
18	Definitions	24
19	Disclaimers	24
20	Contact information	24



© Koninklijke Philips Electronics N.V. 2004

All rights are reserved. Reproduction in whole or in part is prohibited without the prior written consent of the copyright owner. The information presented in this document does not form part of any quotation or contract, is believed to be accurate and reliable and may be changed without notice. No liability will be accepted by the publisher for any consequence of its use. Publication thereof does not convey nor imply any license under patent- or other industrial or intellectual property rights.

Date of release: 12 November 2004
Document number: 9397 750 13812

Published in The Netherlands



LittleDiode supplies new, hard to find or obsolete electronic components and semiconductors all over the world.

With over two million different components listed you are sure to find the part you need.

Feel free to visit us today at our online store:

LittleDiode.com

Looking forward to providing you with the best possible service.