

### Features

- High Conductance
- Fast Switching
- Surface Mount Package Ideally Suited for Automatic Insertion
- For General Purpose and Switching
- Plastic Material – UL Recognition Flammability Classification 94V-O

### Mechanical Data

- Case: SOT-23, Molded Plastic
- Terminals: Plated Leads Solderable per MIL-STD-202, Method 208
- Polarity: See Diagram
- Weight: 0.008 grams (approx.)
- Mounting Position: Any
- Marking: BAS19 A8  
BAS20 A80  
BAS21 A82

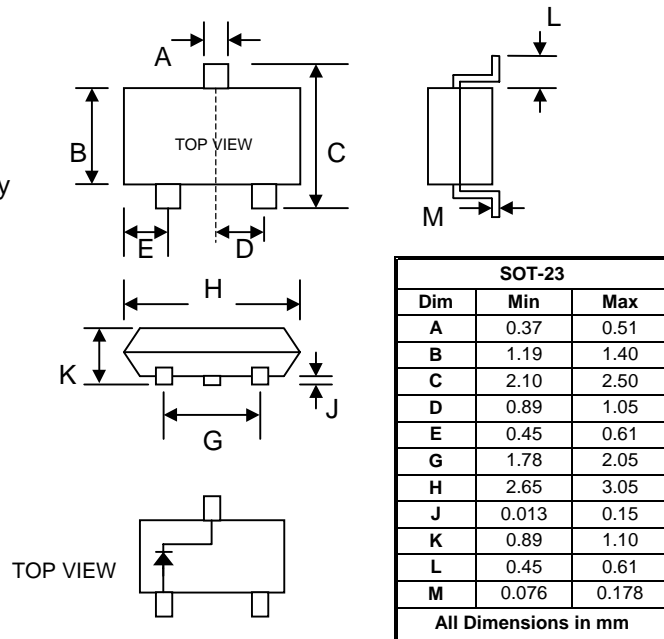

### Maximum Ratings @ $T_A=25^\circ\text{C}$ unless otherwise specified

Characteristic	Symbol	BAS19	BAS20	BAS21	Unit
Non-Repetitive Peak Reverse Voltage	$V_{RM}$	120	200	250	V
Peak Repetitive Reverse Voltage	$V_{RRM}$	100	150	200	V
Working Peak Reverse Voltage	$V_{RWM}$				
DC Blocking Voltage	$V_R$				
Forward Continuous Current (Note 1)	$I_F$	400			mA
Average Rectified Output Current (Note 1)	$I_O$	200			mA
Peak Forward Surge Current (Note 1) @ $t = 1.0\mu\text{s}$	$I_{FSM}$	2.5			A
Power Dissipation (Note 1)	$P_d$	350			mW
Typical Thermal Resistance, Junction to Ambient Air (Note 1)	$R_{\theta JA}$	500			K/W
Operating and Storage Temperature Range	$T_j, T_{STG}$	-65 to +150			$^\circ\text{C}$

### Electrical Characteristics @ $T_A=25^\circ\text{C}$ unless otherwise specified

Characteristic	Symbol	Min	Max	Unit	Test Condition
Forward Voltage	$V_F$	—	1.0 1.25	V	@ $I_F = 100\text{mA}$ @ $I_F = 200\text{mA}$
Reverse Leakage Current	$I_R$	—	100	nA	@ Rated DC Blocking Voltage
Junction Capacitance	$C_j$	—	5.0	pF	$V_R = 0\text{V}, f = 1.0\text{MHz}$
Reverse Recovery Time	$t_{rr}$	—	50	nS	$I_F = I_R = 30\text{mA},$ $I_{RR} = 0.1 \times I_R, R_L = 100\Omega$

Note: 1. Device mounted on fiberglass substrate 40 x 40 x 1.5mm.

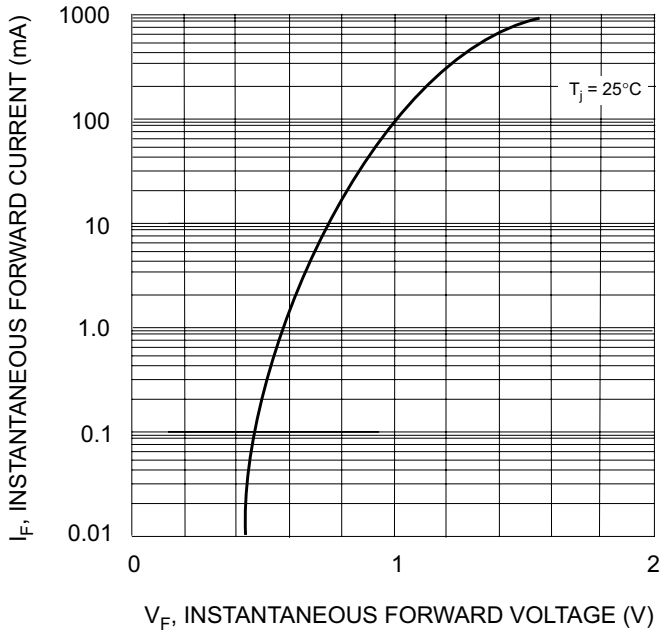

Fig. 1 Forward Characteristics

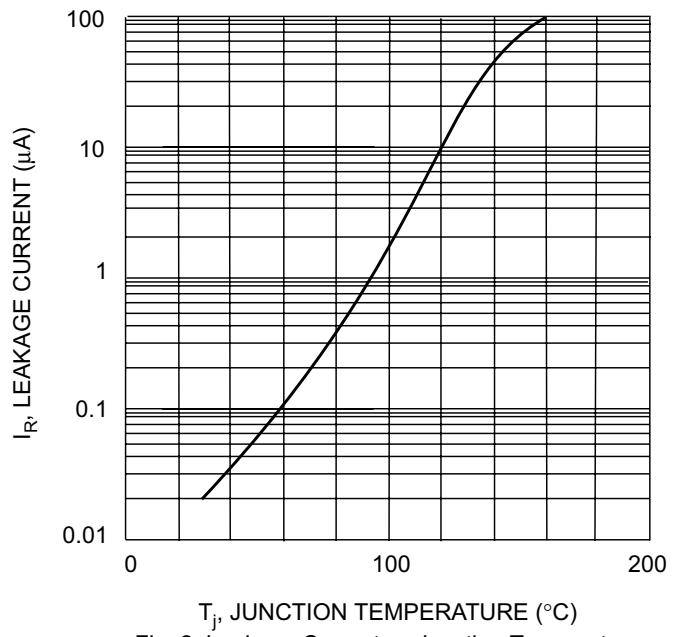

Fig. 2 Leakage Current vs Junction Temperature

## ORDERING INFORMATION

Product No. ♦	Package Type	Shipping Quantity
<b>BAS19-T1</b>	SOT-23	3000/Tape & Reel
BAS19-T3	SOT-23	10000/Tape & Reel
<b>BAS20-T1</b>	SOT-23	3000/Tape & Reel
BAS20-T3	SOT-23	10000/Tape & Reel
<b>BAS21-T1</b>	SOT-23	3000/Tape & Reel
BAS21-T3	SOT-23	10000/Tape & Reel

Products listed in **bold** are WTE **Preferred** devices.

♦T1 suffix refers to a 7" reel. T3 suffix refers to a 13" reel.

Shipping quantity given is for minimum packing quantity only. For minimum order quantity, please consult the Sales Department.

## RECOMMENDED FOOTPRINT

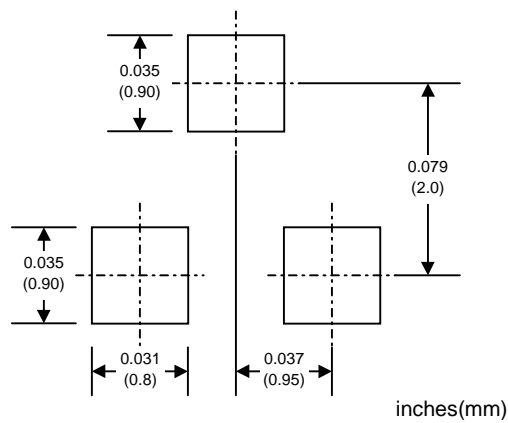

Won-Top Electronics Co., Ltd (WTE) has checked all information carefully and believes it to be correct and accurate. However, WTE cannot assume any responsibility for inaccuracies. Furthermore, this information does not give the purchaser of semiconductor devices any license under patent rights to manufacturer. WTE reserves the right to change any or all information herein without further notice.

**WARNING:** DO NOT USE IN LIFE SUPPORT EQUIPMENT. WTE power semiconductor products are not authorized for use as critical components in life support devices or systems without the express written approval.

**Won-Top Electronics Co., Ltd.**

No. 44 Yu Kang North 3rd Road, Chine Chen Dist., Kaohsiung, Taiwan

**Phone:** 886-7-822-5408 or 886-7-822-5410

**Fax:** 886-7-822-5417

**Email:** sales@wontop.com

**Internet:** <http://www.wontop.com>

*We power your everyday.*



LittleDiode supplies new, hard to find or obsolete electronic components and semiconductors all over the world.

With over two million different components listed you are sure to find the part you need.

Feel free to visit us today at our online store:

[LittleDiode.com](http://LittleDiode.com)

Looking forward to providing you with the best possible service.