

# DATA SHEET

For a complete data sheet, please also download:

- The IC04 LOCMOS HE4000B Logic Family Specifications HEF, HEC
- The IC04 LOCMOS HE4000B Logic Package Outlines/Information HEF, HEC

## **HEF40373B**

### **MSI**

## Octal transparent latch with 3-state outputs

Product specification  
File under Integrated Circuits, IC04

January 1995

# Octal transparent latch with 3-state outputs

## HEF40373B MSI

### DESCRIPTION

The HEF40373B is an 8-bit transparent latch with 3-state buffered outputs. The output stages have high current output capability suitable for driving highly capacitive loads. The latch outputs follow the data inputs when the latch enable (E) is HIGH. When E is LOW, the data that meets the set-up times is latched. The 3-state outputs are controlled by the output enable input  $\overline{EO}$ . A HIGH on

$\overline{EO}$  causes the outputs to assume a high impedance OFF-state. The device features hysteresis on the E input to improve noise rejection. Schmitt-trigger action in the E input makes the circuit highly tolerant to slower input rise and fall times.

The HEF40373B is pin and functionally compatible with the TTL '373' device.

Supply voltage range: 3 to 15 V.

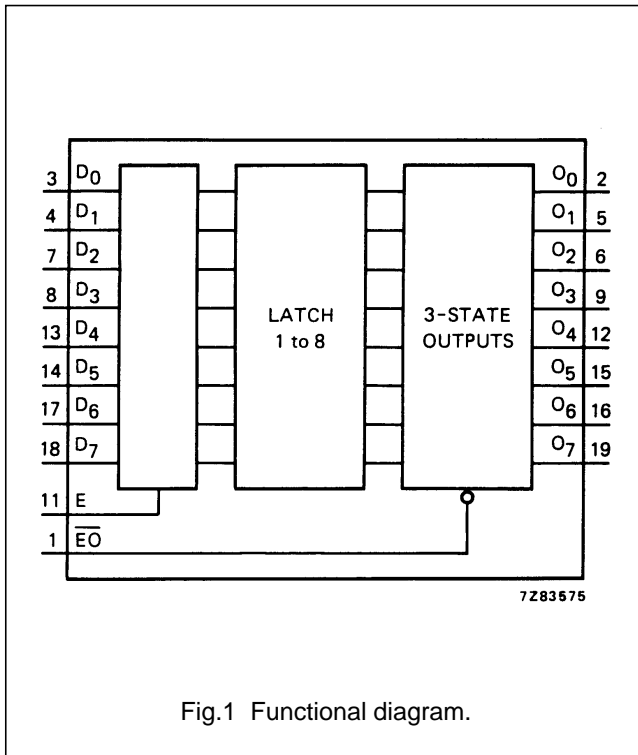

Fig.1 Functional diagram.

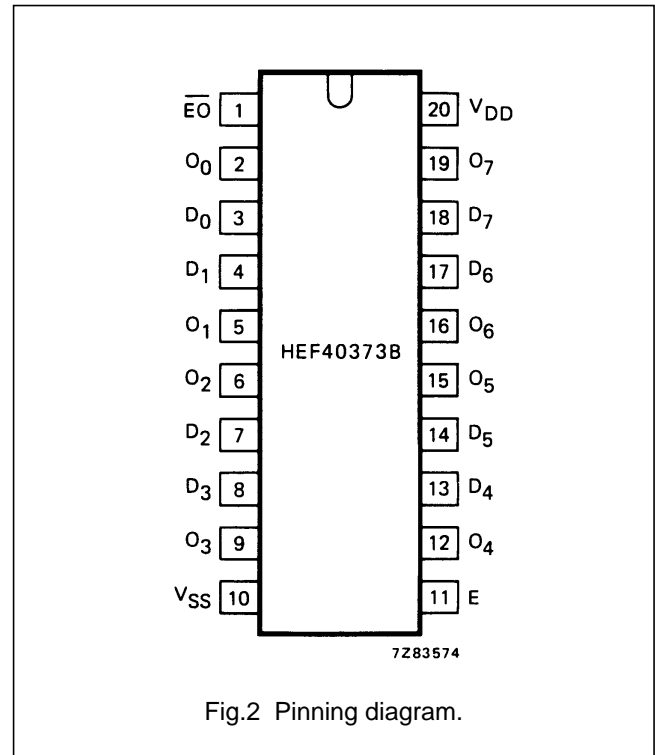

Fig.2 Pinning diagram.

- HEF40373BP(N): 20-lead DIL; plastic (SOT146-1)
- HEF40373BD(F): 20-lead DIL; ceramic (cerdip) (SOT152)
- HEF40373BT(D): 20-lead SO; plastic (SOT163-1)
- ( ): Package Designator North America

### PINNING

- D<sub>0</sub> to D<sub>7</sub> data inputs
- E latch enable input
- $\overline{EO}$  output enable input (active LOW)
- O<sub>0</sub> to O<sub>7</sub> 3-state buffered outputs

### FAMILY DATA, I<sub>DD</sub> LIMITS category MSI

See Family Specifications

# Octal transparent latch with 3-state outputs

HEF40373B  
MSI

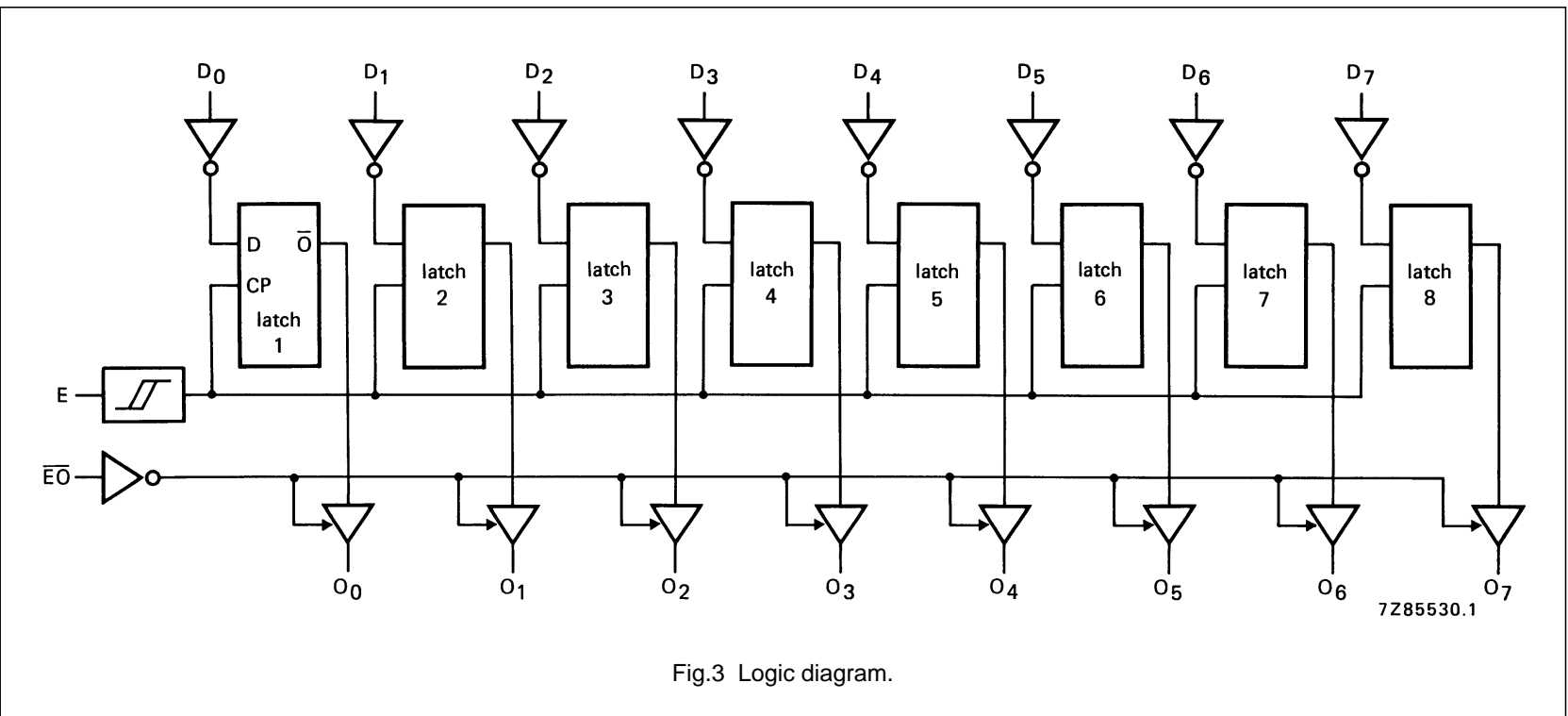

Fig.3 Logic diagram.

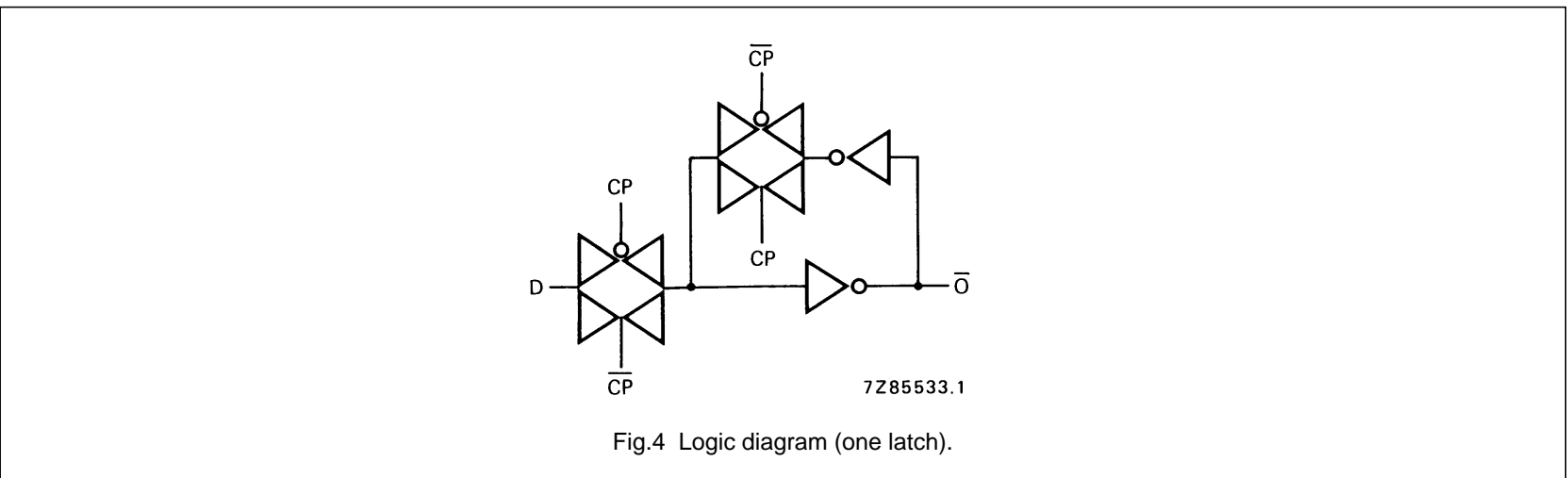

Fig.4 Logic diagram (one latch).

## Octal transparent latch with 3-state outputs

HEF40373B  
MSI

## FUNCTION TABLE

OPERATING MODES	INPUTS			INTERNAL REGISTER	OUTPUTS O <sub>0</sub> TO O <sub>7</sub>
	$\overline{EO}$	E	D <sub>n</sub>		
enable & read register	L	H	L	L	L
	L	H	H	H	H
latch & read register	L	L	l	L	L
	L	L	h	H	H
latch register & disable outputs	H	L	l	L	Z
	H	L	h	H	Z

## Notes

- H = HIGH state (the more positive voltage)  
 h = HIGH state (one set-up time prior to the HIGH-to-LOW enable transition)  
 L = LOW state (the less positive voltage)  
 l = LOW state (one set-up time prior to the HIGH-to-LOW enable transition)  
 Z = high impedance OFF-state

# Octal transparent latch with 3-state outputs

HEF40373B  
MSI

## RATINGS

Limiting values in accordance with the Absolute Maximum System (IEC 134)

See Family Specifications, except for:

D.C. current into any input	$\pm I_I$	max.	10 mA
D.C. source or sink current into any output	$\pm I_O$	max.	25 mA
D.C. current into the supply terminals	$\pm I$	max.	100 mA

## DC CHARACTERISTICS

$V_{SS} = 0\text{ V}$

	$V_{DD}$ V	$V_{OH}$ V	$V_{OL}$ V	SYMBOL	$T_{amb} (\text{°C})$					
					-40		+25		+85	
					MIN.	TYP.	MIN.	TYP.	MIN.	TYP.
Output current HIGH	5	4,6		$-I_{OH}$	0,75	0,6	1,2	0,45	mA	
	10	9,5			1,85	1,5	3,0	1,1	mA	
	15	13,5			14,5	15	50	15,5	mA	
Output current HIGH	5	3,6		$-I_{OH}$	9,3	10	24	10,7	mA	
	10	8,4			14,4	15	46	15,0	mA	
	15	13,2			19,5	20	62	19,8	mA	
Output current LOW	5		0,4	$I_{OL}$	2,9	2,3	5,4	1,75	mA	
	10		0,5		9,5	7,6	17	5,50	mA	
	15		1,5		30,0	25	45	19,0	mA	
Hysteresis voltage at enable input (E)	5			$V_H$			220		mV	
	10						250		mV	
	15						320		mV	

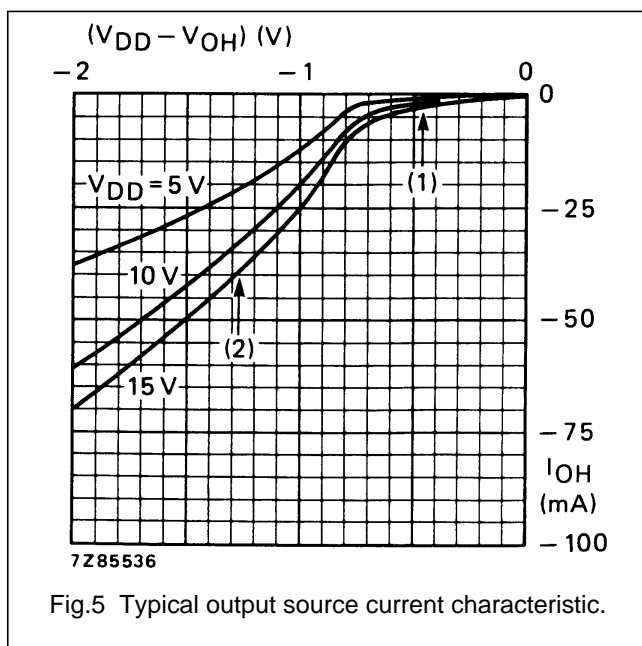
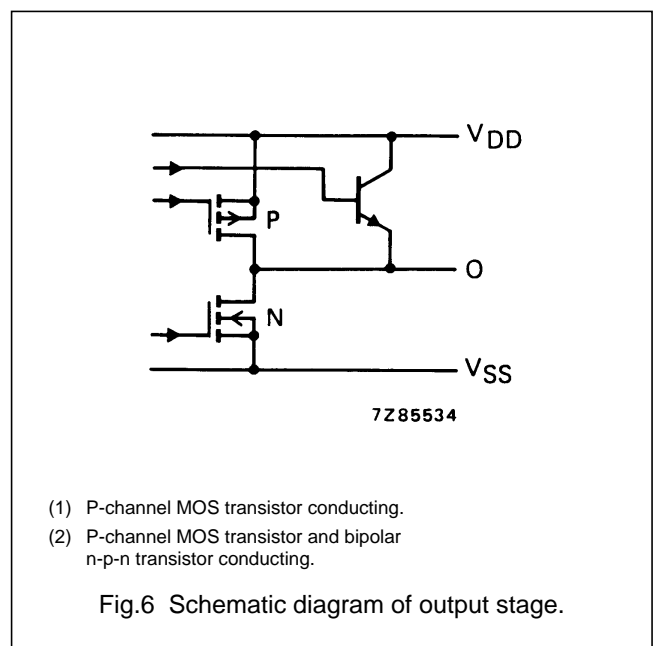

Fig.5 Typical output source current characteristic.



- (1) P-channel MOS transistor conducting.
- (2) P-channel MOS transistor and bipolar n-p-n transistor conducting.

Fig.6 Schematic diagram of output stage.

## Octal transparent latch with 3-state outputs

HEF40373B  
MSI**AC CHARACTERISTICS** $V_{SS} = 0\text{ V}$ ;  $T_{amb} = 25\text{ }^{\circ}\text{C}$ ;  $C_L = 50\text{ pF}$ ; input transition times  $\leq 20\text{ ns}$ 

	$V_{DD}$ V	SYMBOL	MIN.	TYP.	MAX.	TYPICAL EXTRAPOLATION FORMULA		
Propagation delays $E \rightarrow O_n$ HIGH to LOW	5	$t_{PHL}$		150	300	ns	138 ns + (0,24 ns/pF) $C_L$	
	10		60	120	ns	59 ns + (0,01 ns/pF) $C_L$		
	15		40	80	ns	36 ns + (0,07 ns/pF) $C_L$		
	$E \rightarrow O_n$ LOW to HIGH	5	$t_{PLH}$		125	250	ns	122 ns + (0,06 ns/pF) $C_L$
		10		50	100	ns	48 ns + (0,03 ns/pF) $C_L$	
		15		40	80	ns	39 ns + (0,02 ns/pF) $C_L$	
Output transition times HIGH to LOW	5	$t_{THL}$		40	80	ns	see Fig.7	
	10		20	40	ns			
	15		15	30	ns			
	LOW to HIGH	5	$t_{TLH}$		30	60		ns
		10		20	40	ns		
		15		15	30	ns		
3-state propagation delays Output disable times $\overline{EO} \rightarrow O_n$ HIGH	5	$t_{PHZ}$		65	130	ns		
	10		30	60	ns			
	15		25	50	ns			
	LOW	5	$t_{PLZ}$		75	150	ns	
		10		40	80	ns		
		15		30	60	ns		
Output enable times $\overline{EO} \rightarrow O_n$ HIGH	5	$t_{PZH}$		65	130	ns		
	10		30	60	ns			
	15		25	50	ns			
	LOW	5	$t_{PZL}$		85	170	ns	
		10		35	70	ns		
		15		25	50	ns		
Set-up time $D_n \rightarrow E$	5	$t_{su}$	15	7		ns		
	10		10	5		ns		
	15		10	5		ns		
Hold time $D_n \rightarrow E$	5	$t_{hold}$	25	15		ns		
	10		15	4		ns		
	15		10	3		ns		
Minimum latch enable pulse width LOW	5	$t_{WEL}$	60	30		ns		
	10		30	15		ns		
	15		20	10		ns		

Octal transparent latch with 3-state outputs

HEF40373B  
MSI

AC CHARACTERISTICS

V<sub>SS</sub> = 0 V; T<sub>amb</sub> = 25 °C; input transition times ≤ 20 ns

	V <sub>DD</sub> V	TYPICAL FORMULA FOR P (μW)	
Dynamic power dissipation per package (P)	5	$3\ 325 f_i + \sum (f_o C_L) \times V_{DD}^2$	where f <sub>i</sub> = input freq. (MHz) f <sub>o</sub> = output freq. (MHz) C <sub>L</sub> = load capacitance (pF) ∑ (f <sub>o</sub> C <sub>L</sub> ) = sum of outputs V <sub>DD</sub> = supply voltage (V)
	10	$14\ 200 f_i + \sum (f_o C_L) \times V_{DD}^2$	
	15	$37\ 425 f_i + \sum (f_o C_L) \times V_{DD}^2$	

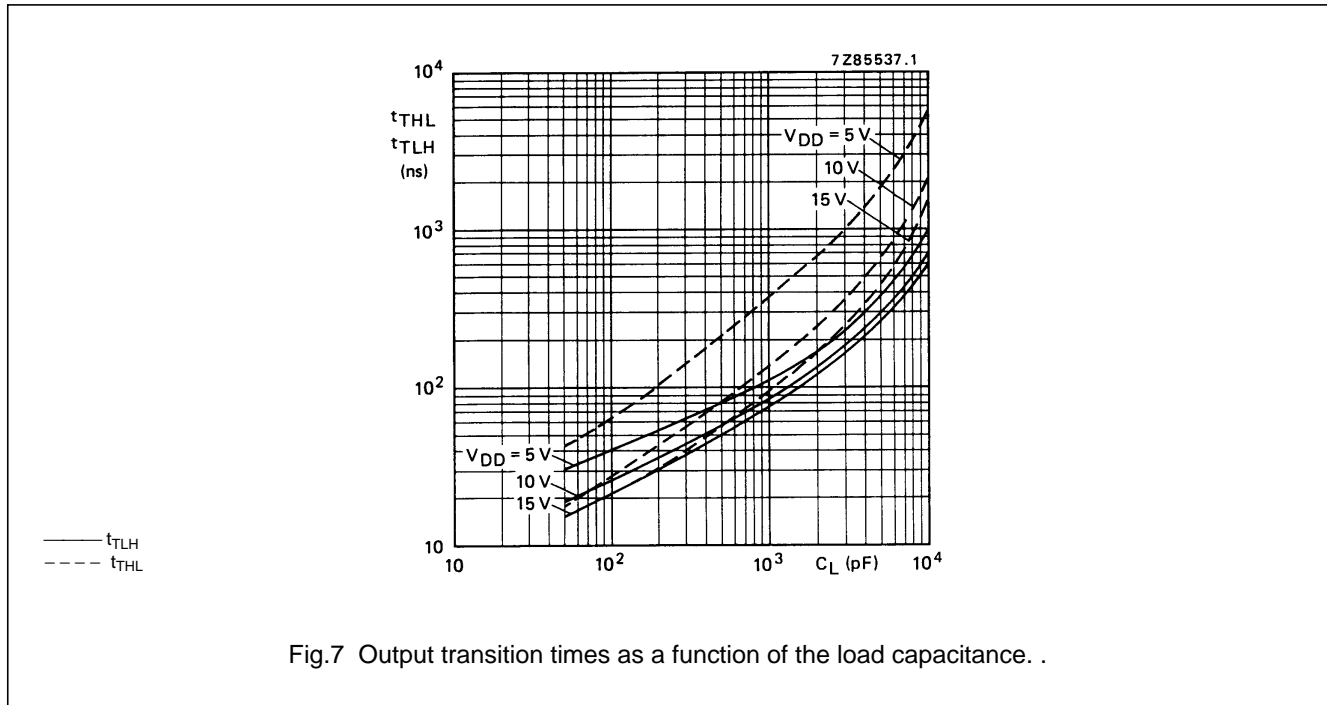



LittleDiode supplies new, hard to find or obsolete electronic components and semiconductors all over the world.

With over two million different components listed you are sure to find the part you need.

Feel free to visit us today at our online store:

[LittleDiode.com](http://LittleDiode.com)

Looking forward to providing you with the best possible service.