

HEF4094B

8-stage shift-and-store register

Rev. 11 — 29 August 2013

Product data sheet

1. General description

The HEF4094B is an 8-stage serial shift register. It has a storage latch associated with each stage for strobing data from the serial input to parallel buffered 3-state outputs QP0 to QP7. The parallel outputs may be connected directly to common bus lines. Data is shifted on positive-going clock transitions. The data in each shift register stage is transferred to the storage register when the strobe (STR) input is HIGH. Data in the storage register appears at the outputs whenever the output enable (OE) signal is HIGH.

Two serial outputs (QS1 and QS2) are available for cascading a number of HEF4094B devices. Serial data is available at QS1 on positive-going clock edges to allow high-speed operation in cascaded systems with a fast clock rise time. The same serial data is available at QS2 on the next negative going clock edge. This is used for cascading HEF4094B devices when the clock has a slow rise time.

It operates over a recommended V_{DD} power supply range of 3 V to 15 V referenced to V_{SS} (usually ground). Unused inputs must be connected to V_{DD} , V_{SS} , or another input.

2. Features and benefits

- Fully static operation
- 5 V, 10 V, and 15 V parametric ratings
- Standardized symmetrical output characteristics
- Specified from $-40\text{ }^{\circ}\text{C}$ to $+85\text{ }^{\circ}\text{C}$ and $-40\text{ }^{\circ}\text{C}$ to $+125\text{ }^{\circ}\text{C}$
- Complies with JEDEC standard JESD 13-B

3. Ordering information

Table 1. Ordering information

All types operate from $-40\text{ }^{\circ}\text{C}$ to $+125\text{ }^{\circ}\text{C}$.

Type number	Package		Version
	Name	Description	
HEF4094BP	DIP16	plastic dual in-line package; 16 leads (300 mil)	SOT38-4
HEF4094BT	SO16	plastic small outline package; 16 leads; body width 3.9 mm	SOT109-1
HEF4094BTS	SSOP16	plastic shrink small outline package; 16 leads; body width 5.3 mm	SOT338-1
HEF4094BTT	TSSOP16	plastic thin shrink small outline package; 16 leads; body width 4.4 mm	SOT403-1



4. Functional diagram

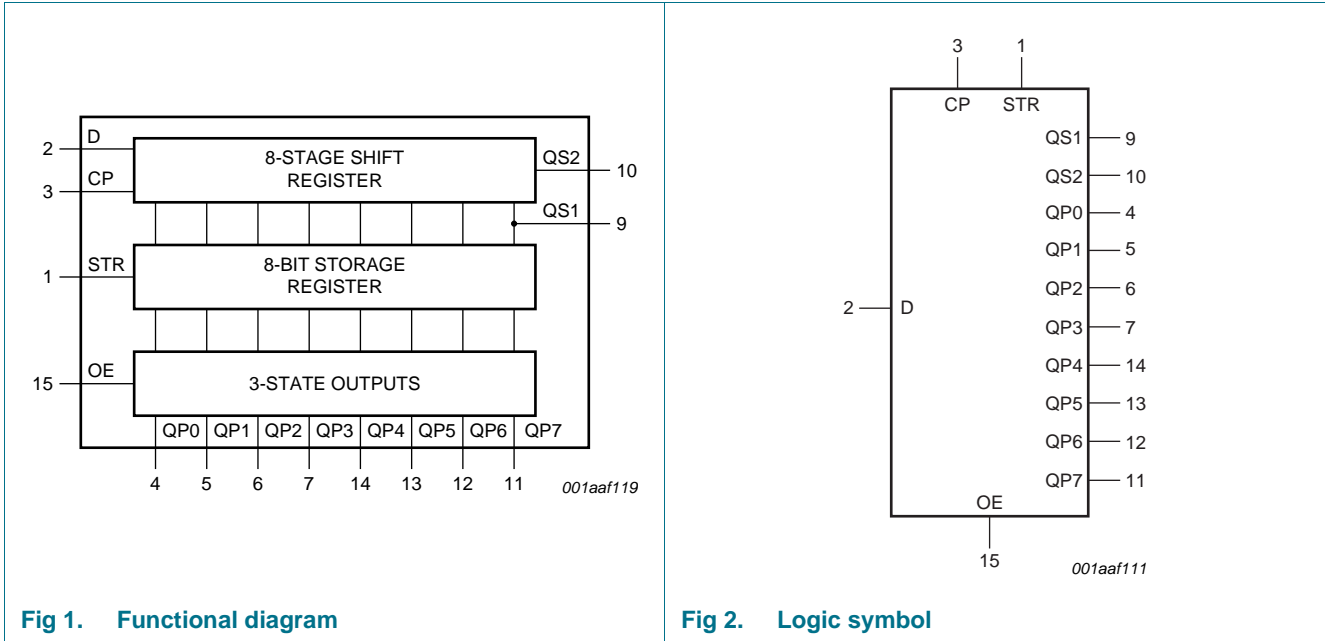

Fig 1. Functional diagram

Fig 2. Logic symbol

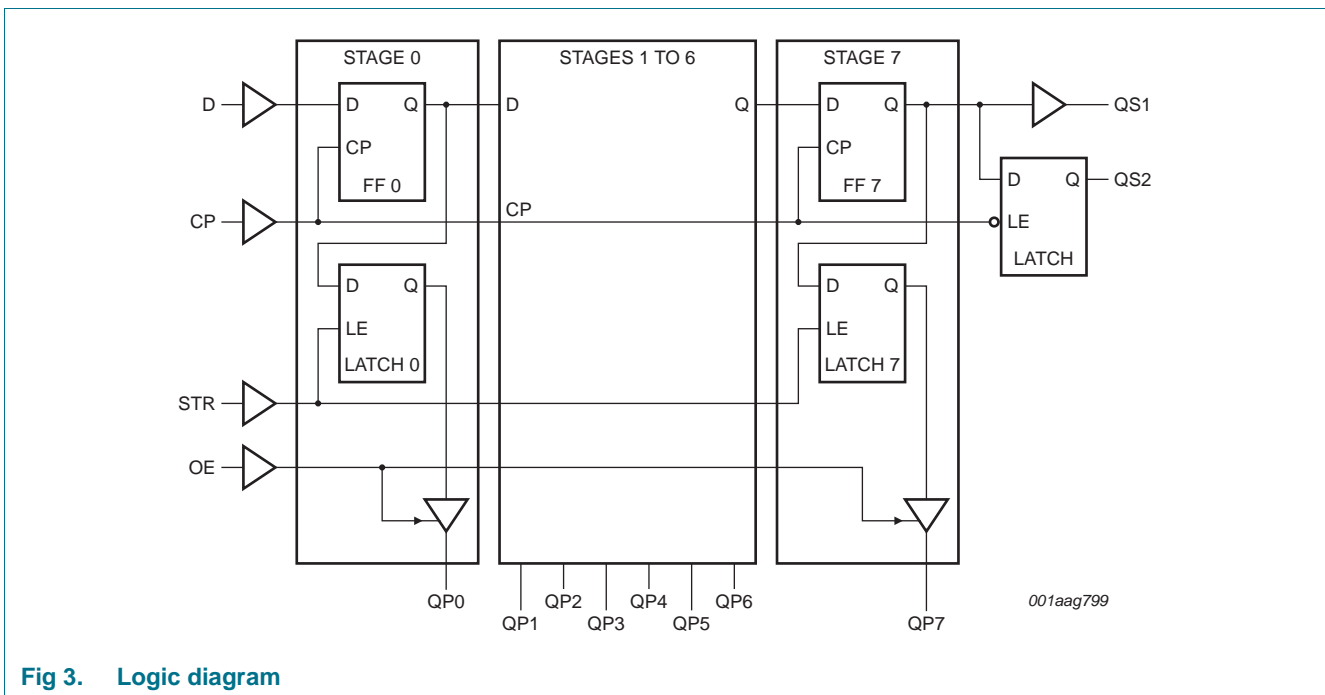
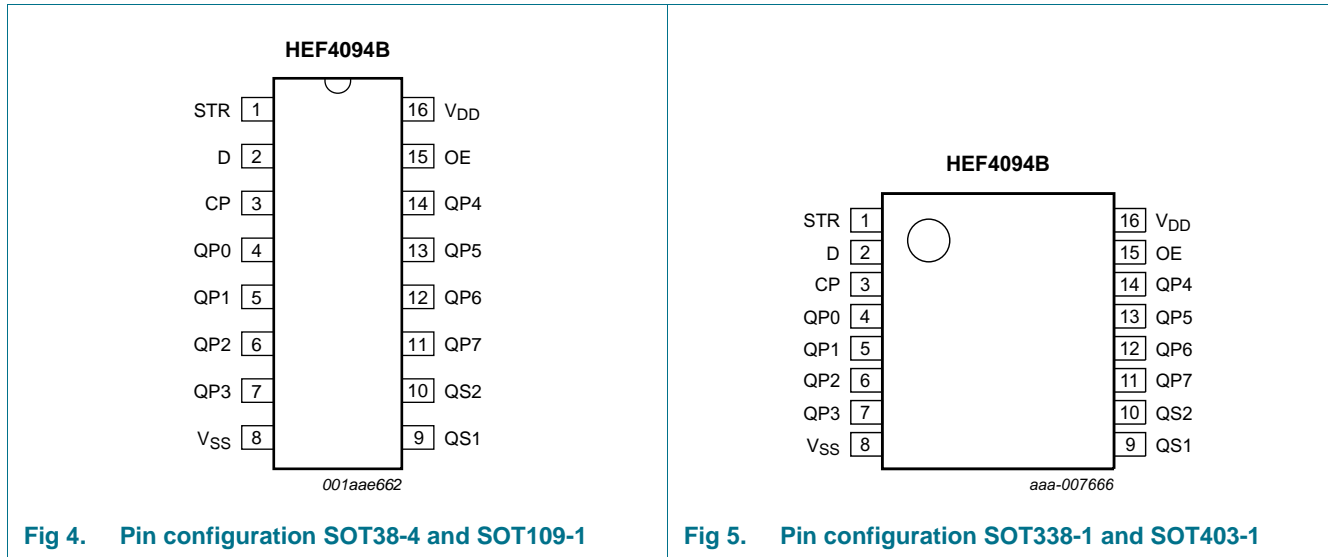

Fig 3. Logic diagram

5. Pinning information

5.1 Pinning



5.2 Pin description

Table 2. Pin description

Symbol	Pin	Description
STR	1	strobe input
D	2	data input
CP	3	clock input
QP0 to QP7	4, 5, 6, 7, 14, 13, 12, 11	parallel output
V _{SS}	8	ground supply voltage
QS1	9	serial output
QS2	10	serial output
OE	15	output enable input
V _{DD}	16	supply voltage

6. Functional description

Table 3. Function table^[1]

Inputs				Parallel outputs		Serial outputs	
CP	OE	STR	D	QP0	QPn	QS1	QS2
↑	L	X	X	Z	Z	Q6S	NC
↓	L	X	X	Z	Z	NC	Q7S
↑	H	L	X	NC	NC	Q6S	NC
↑	H	H	L	L	QPn - 1	Q6S	NC
↑	H	H	H	H	QPn - 1	Q6S	NC
↓	H	H	H	NC	NC	NC	Q7S

- [1] At the positive clock edge, the information in the 7th register stage is transferred to the 8th register stage and the QSn outputs.
 H = HIGH voltage level; L = LOW voltage level; X = don't care;
 ↑ = positive-going transition; ↓ = negative-going transition;
 Z = HIGH-impedance OFF-state; NC = no change;
 Q6S = the data in register stage 6 before the LOW to HIGH clock transition;
 Q7S = the data in register stage 7 before the HIGH to LOW clock transition.

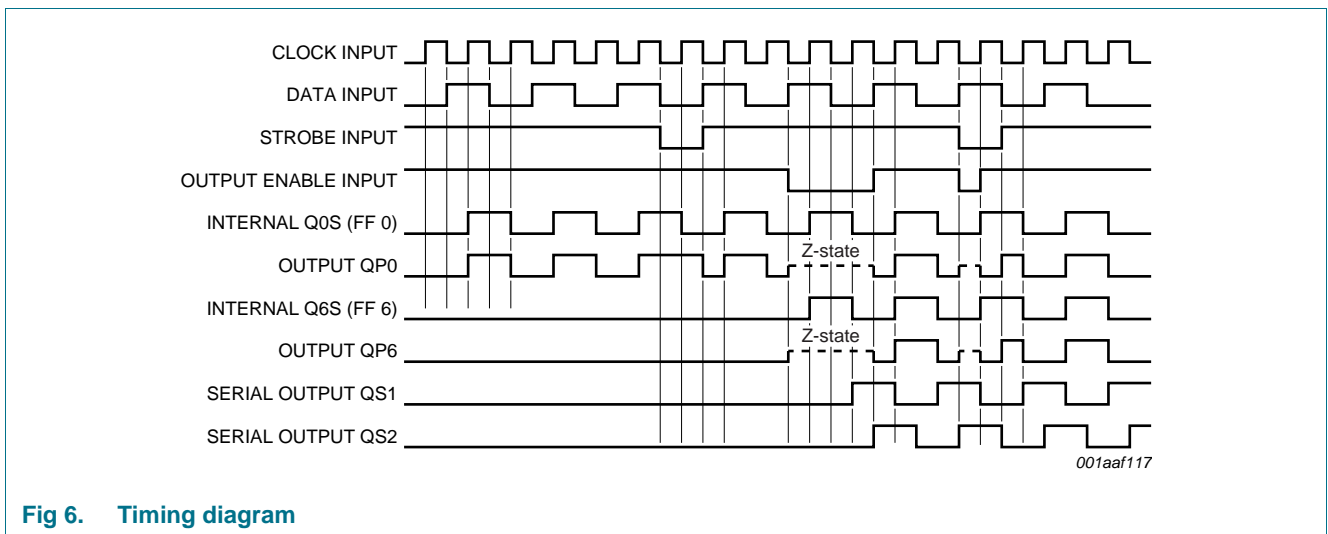

Fig 6. Timing diagram

7. Limiting values

Table 4. Limiting values

In accordance with the Absolute Maximum Rating System (IEC 60134). Voltages are referenced to $V_{SS} = 0$ V (ground).

Symbol	Parameter	Conditions	Min	Max	Unit	
V_{DD}	supply voltage		-0.5	+18	V	
I_{IK}	input clamping current	$V_I < -0.5$ V or $V_I > V_{DD} + 0.5$ V	-	± 10	mA	
V_I	input voltage		-0.5	$V_{DD} + 0.5$	V	
I_{OK}	output clamping current	$V_O < -0.5$ V or $V_O > V_{DD} + 0.5$ V	-	± 10	mA	
$I_{I/O}$	input/output current		-	± 10	mA	
I_{DD}	supply current		-	50	mA	
T_{stg}	storage temperature		-65	+150	°C	
T_{amb}	ambient temperature		-40	+125	°C	
P_{tot}	total power dissipation	DIP16	[1]	-	750	mW
		SO16, SSOP16 and TSSOP16	[2]	-	500	mW
P	power dissipation	per output	-	100	mW	

[1] For DIP16 packages: above $T_{amb} = 70$ °C, P_{tot} derates linearly with 12 mW/K.

[2] For SO16 package: P_{tot} derates linearly with 8 mW/K above 70 °C.

For (T)SSOP16 package: P_{tot} derates linearly with 5.5 mW/K above 60 °C.

8. Recommended operating conditions

Table 5. Recommended operating conditions

Symbol	Parameter	Conditions	Min	Typ	Max	Unit
V_{DD}	supply voltage		3	-	15	V
V_I	input voltage		0	-	V_{DD}	V
T_{amb}	ambient temperature	in free air	-40	-	+125	°C
$\Delta t/\Delta V$	input transition rise and fall rate	$V_{DD} = 5$ V	-	-	3.75	$\mu\text{s/V}$
		$V_{DD} = 10$ V	-	-	0.5	$\mu\text{s/V}$
		$V_{DD} = 15$ V	-	-	0.08	$\mu\text{s/V}$

9. Static characteristics

Table 6. Static characteristics

$V_{SS} = 0\text{ V}$; $V_I = V_{SS}$ or V_{DD} ; unless otherwise specified.

Symbol	Parameter	Conditions	V_{DD}	$T_{amb} = -40\text{ °C}$		$T_{amb} = +25\text{ °C}$		$T_{amb} = +85\text{ °C}$		$T_{amb} = +125\text{ °C}$		Unit
				Min	Max	Min	Max	Min	Max	Min	Max	
V_{IH}	HIGH-level input voltage	$ I_O < 1\text{ }\mu\text{A}$	5 V	3.5	-	3.5	-	3.5	-	3.5	-	V
			10 V	7.0	-	7.0	-	7.0	-	7.0	-	V
			15 V	11.0	-	11.0	-	11.0	-	11.0	-	V
V_{IL}	LOW-level input voltage	$ I_O < 1\text{ }\mu\text{A}$	5 V	-	1.5	-	1.5	-	1.5	-	1.5	V
			10 V	-	3.0	-	3.0	-	3.0	-	3.0	V
			15 V	-	4.0	-	4.0	-	4.0	-	4.0	V
V_{OH}	HIGH-level output voltage	$ I_O < 1\text{ }\mu\text{A}$	5 V	4.95	-	4.95	-	4.95	-	4.95	-	V
			10 V	9.95	-	9.95	-	9.95	-	9.95	-	V
			15 V	14.95	-	14.95	-	14.95	-	14.95	-	V
V_{OL}	LOW-level output voltage	$ I_O < 1\text{ }\mu\text{A}$	5 V	-	0.05	-	0.05	-	0.05	-	0.05	V
			10 V	-	0.05	-	0.05	-	0.05	-	0.05	V
			15 V	-	0.05	-	0.05	-	0.05	-	0.05	V
I_{OH}	HIGH-level output current	$V_O = 2.5\text{ V}$	5 V	-	-1.7	-	-1.4	-	-1.1	-	-1.1	mA
		$V_O = 4.6\text{ V}$	5 V	-	-0.64	-	-0.5	-	-0.36	-	-0.36	mA
		$V_O = 9.5\text{ V}$	10 V	-	-1.6	-	-1.3	-	-0.9	-	-0.9	mA
		$V_O = 13.5\text{ V}$	15 V	-	-4.2	-	-3.4	-	-2.4	-	-2.4	mA
I_{OL}	LOW-level output current	$V_O = 0.4\text{ V}$	5 V	0.64	-	0.5	-	0.36	-	0.36	-	mA
		$V_O = 0.5\text{ V}$	10 V	1.6	-	1.3	-	0.9	-	0.9	-	mA
		$V_O = 1.5\text{ V}$	15 V	4.2	-	3.4	-	2.4	-	2.4	-	mA
I_{OZ}	OFF-state output current	QPn output is HIGH; $V_O = 15\text{ V}$	15 V	-	0.4	-	0.4	-	12	-	12	μA
I_I	input leakage current		15 V	-	± 0.1	-	± 0.1	-	± 1.0	-	± 1.0	μA
I_{DD}	supply current	all valid input combinations; $I_O = 0\text{ A}$	5 V	-	5	-	5	-	150	-	150	μA
			10 V	-	10	-	10	-	300	-	300	μA
			15 V	-	20	-	20	-	600	-	600	μA
C_I	input capacitance			-	-	-	7.5	-	-	-	pF	

10. Dynamic characteristics

Table 7. Dynamic characteristics

$V_{SS} = 0\text{ V}$; $T_{amb} = 25\text{ °C}$; for test circuit see [Figure 11](#); unless otherwise specified.

Symbol	Parameter	Conditions	V _{DD}	Extrapolation formula	Min	Typ	Max	Unit
t _{PHL}	HIGH to LOW propagation delay	CP to QS1; see Figure 7	5 V	[1] 108 ns + (0.55 ns/pF)C _L	-	135	270	ns
			10 V	54 ns + (0.23 ns/pF)C _L	-	65	130	ns
			15 V	42 ns + (0.16 ns/pF)C _L	-	50	100	ns
		CP to QS2; see Figure 7	5 V	78 ns + (0.55 ns/pF)C _L	-	105	210	ns
			10 V	39 ns + (0.23 ns/pF)C _L	-	50	100	ns
			15 V	32 ns + (0.16 ns/pF)C _L	-	40	80	ns
		CP to QPn; see Figure 7	5 V	138 ns + (0.55 ns/pF)C _L	-	165	330	ns
			10 V	64 ns + (0.23 ns/pF)C _L	-	75	150	ns
			15 V	47 ns + (0.16 ns/pF)C _L	-	55	110	ns
		STR to QPn; see Figure 8	5 V	83 ns + (0.55 ns/pF)C _L	-	110	220	ns
			10 V	39 ns + (0.23 ns/pF)C _L	-	50	100	ns
			15 V	27 ns + (0.16 ns/pF)C _L	-	35	70	ns
t _{PLH}	LOW to HIGH propagation delay,	CP to QS1; see Figure 7	5 V	[1] 78 ns + (0.55 ns/pF)C _L	-	105	210	ns
			10 V	39 ns + (0.23 ns/pF)C _L	-	50	100	ns
			15 V	32 ns + (0.16 ns/pF)C _L	-	40	80	ns
		CP to QS2; see Figure 7	5 V	78 ns + (0.55 ns/pF)C _L	-	105	210	ns
			10 V	39 ns + (0.23 ns/pF)C _L	-	50	100	ns
			15 V	32 ns + (0.16 ns/pF)C _L	-	40	80	ns
		CP to QPn; see Figure 7	5 V	123 ns + (0.55 ns/pF)C _L	-	150	300	ns
			10 V	59 ns + (0.23 ns/pF)C _L	-	70	140	ns
			15 V	47 ns + (0.16 ns/pF)C _L	-	55	110	ns
		STR to QPn; see Figure 8	5 V	73 ns + (0.55 ns/pF)C _L	-	100	200	ns
			10 V	34 ns + (0.23 ns/pF)C _L	-	45	90	ns
			15 V	27 ns + (0.16 ns/pF)C _L	-	35	70	ns
t _t	transition time		5 V	[1] 10 ns + (1.00 ns/pF)C _L	-	60	120	ns
			10 V	9 ns + (0.42 ns/pF)C _L	-	30	60	ns
			15 V	6 ns + (0.28 ns/pF)C _L	-	20	40	ns
t _{PZH}	OFF-state to HIGH propagation delay	OE to QPn; see Figure 9	5 V		-	40	80	ns
			10 V		-	25	50	ns
			15 V		-	20	40	ns
t _{PZL}	OFF-state to LOW propagation delay	OE to QPn; see Figure 9	5 V		-	40	80	ns
			10 V		-	25	50	ns
			15 V		-	20	40	ns
t _{PHZ}	HIGH to OFF-state propagation delay	OE to QPn; see Figure 9	5 V		-	75	150	ns
			10 V		-	40	80	ns
			15 V		-	30	60	ns

Table 7. Dynamic characteristics ...continued
 $V_{SS} = 0\text{ V}$; $T_{amb} = 25\text{ °C}$; for test circuit see [Figure 11](#); unless otherwise specified.

Symbol	Parameter	Conditions	V_{DD}	Extrapolation formula	Min	Typ	Max	Unit
t_{PLZ}	LOW to OFF-state propagation delay	OE to QPn; see Figure 9	5 V		-	80	160	ns
			10 V		-	40	80	ns
			15 V		-	30	60	ns
t_{su}	set-up time	D to CP; see Figure 10	5 V		60	30	-	ns
			10 V		20	10	-	ns
			15 V		15	5	-	ns
t_h	hold time	D to CP; see Figure 10	5 V		+5	-15	-	ns
			10 V		20	5	-	ns
			15 V		20	5	-	ns
t_w	pulse width	minimum LOW clock pulse; see Figure 7	5 V		60	30	-	ns
			10 V		30	15	-	ns
			15 V		24	12	-	ns
		minimum HIGH strobe pulse; see Figure 8	5 V		40	20	-	ns
			10 V		30	15	-	ns
			15 V		24	12	-	ns
f_{max}	maximum frequency	see Figure 7	5 V		5	10	-	MHz
			10 V		11	22	-	MHz
			15 V		14	28	-	MHz

[1] The typical values of the propagation delay and transition times are calculated from the extrapolation formulas shown (C_L in pF).

Table 8. Dynamic power dissipation
 $V_{SS} = 0\text{ V}$; $t_r = t_f \leq 20\text{ ns}$; $T_{amb} = 25\text{ °C}$.

Symbol	Parameter	V_{DD}	Typical formula for P_D (μW)	where:
P_D	dynamic power dissipation	5 V	$P_D = 2100 \times f_i + \Sigma(f_o \times C_L) \times V_{DD}^2$	f_i = input frequency in MHz,
		10 V	$P_D = 9700 \times f_i + \Sigma(f_o \times C_L) \times V_{DD}^2$	f_o = output frequency in MHz,
		15 V	$P_D = 26000 \times f_i + \Sigma(f_o \times C_L) \times V_{DD}^2$	C_L = output load capacitance in pF,
				V_{DD} = supply voltage in V,
				$\Sigma(f_o \times C_L)$ = sum of the outputs.

11. Waveforms

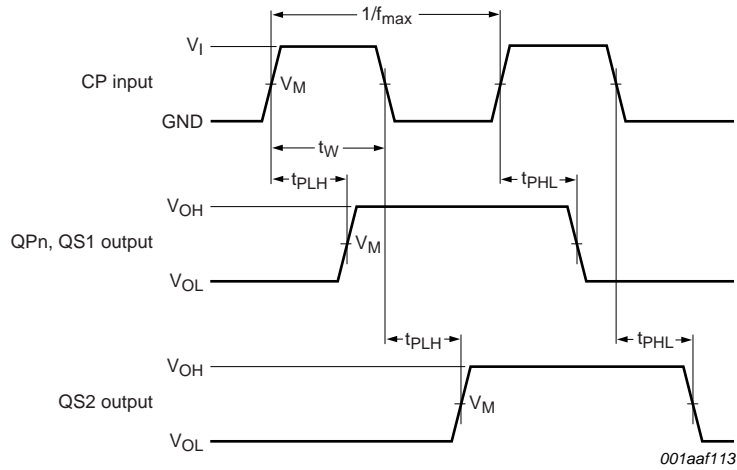

Measurement points are given in [Table 9](#).
 Logic levels: V_{OL} and V_{OH} are typical output voltage levels that occur with the output load.

Fig 7. Clock to outputs propagation delays, and clock pulse width and maximum frequency

Table 9. Measurement points

Supply voltage	Input	Output		
V_{DD}	V_M	V_M	V_X	V_Y
5 V to 15 V	$0.5V_{DD}$	$0.5V_{DD}$	$0.1V_{DD}$	$0.9V_{DD}$

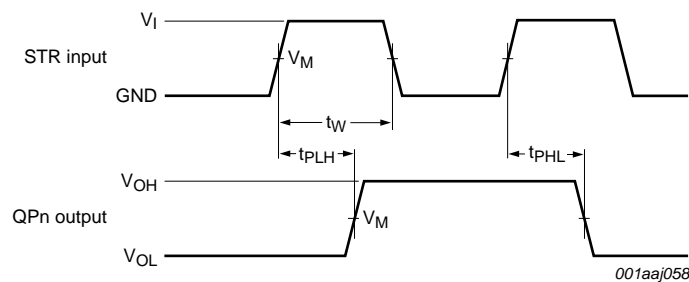

Measurement points are given in [Table 9](#).
 Logic levels: V_{OL} and V_{OH} are typical output voltage levels that occur with the output load.

Fig 8. Strobe to output propagation delays, and strobe pulse width, set up and hold times

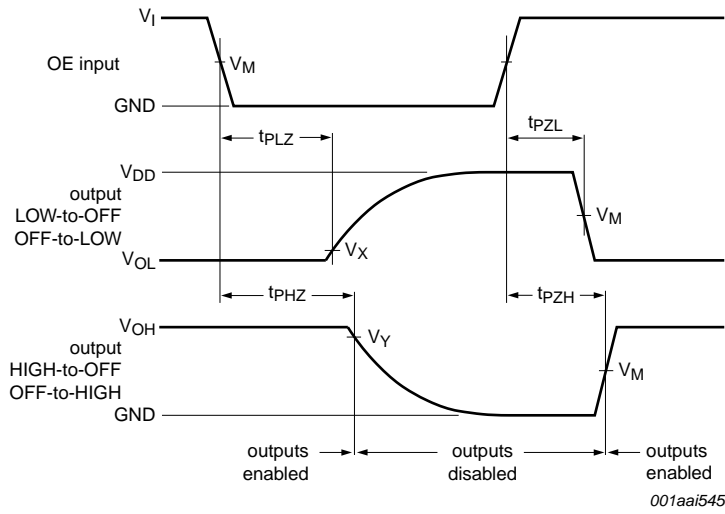

Measurement points are given in [Table 9](#).
 Logic levels: V_{OL} and V_{OH} are typical output voltage levels that occur with the output load.

Fig 9. 3-state output enable and disable times for OE input

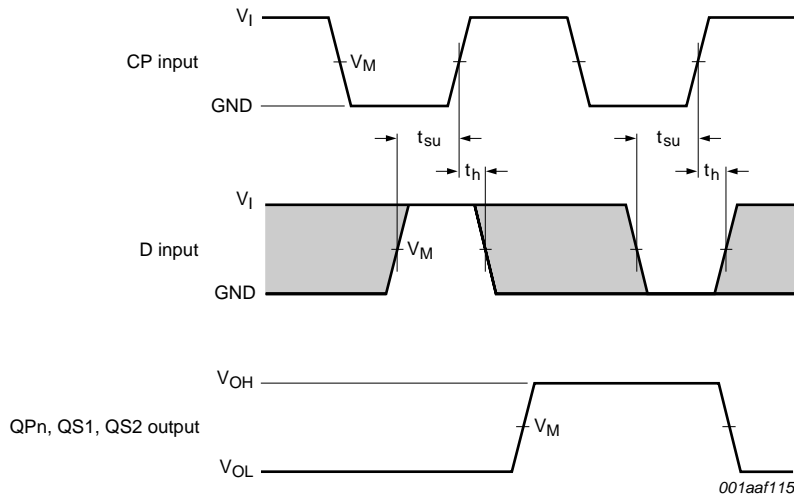

Measurement points are given in [Table 9](#).
 Logic levels: V_{OL} and V_{OH} are typical output voltage levels that occur with the output load.

Fig 10. Data input data set up and hold times

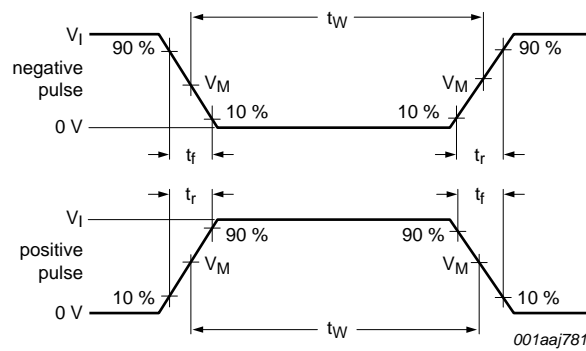

a. Input waveform

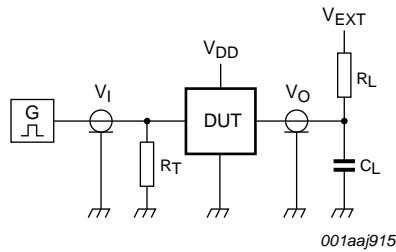

b. Test circuit

Test data is given in [Table 10](#).

Definitions for test circuit:

DUT = Device Under Test.

C_L = load capacitance including jig and probe capacitance.

R_L = load resistance.

R_T = termination resistance should be equal to the output impedance Z_o of the pulse generator.

Fig 11. Test circuit

Table 10. Test data

Supply voltage	Input		V_{EXT}			Load	
V_{DD}	V_I	t_r, t_f	t_{PHL}, t_{PLH}	t_{PHZ}, t_{PZH}	t_{PLZ}, t_{PZL}	C_L	R_L
5 V to 15 V	V_{SS} or V_{DD}	≤ 20 ns	open	V_{SS}	V_{DD}	50 pF	1 k Ω

12. Application information

Some examples of applications for the HEF4094B are:

- Serial-to-parallel data conversion
- Remote control holding register

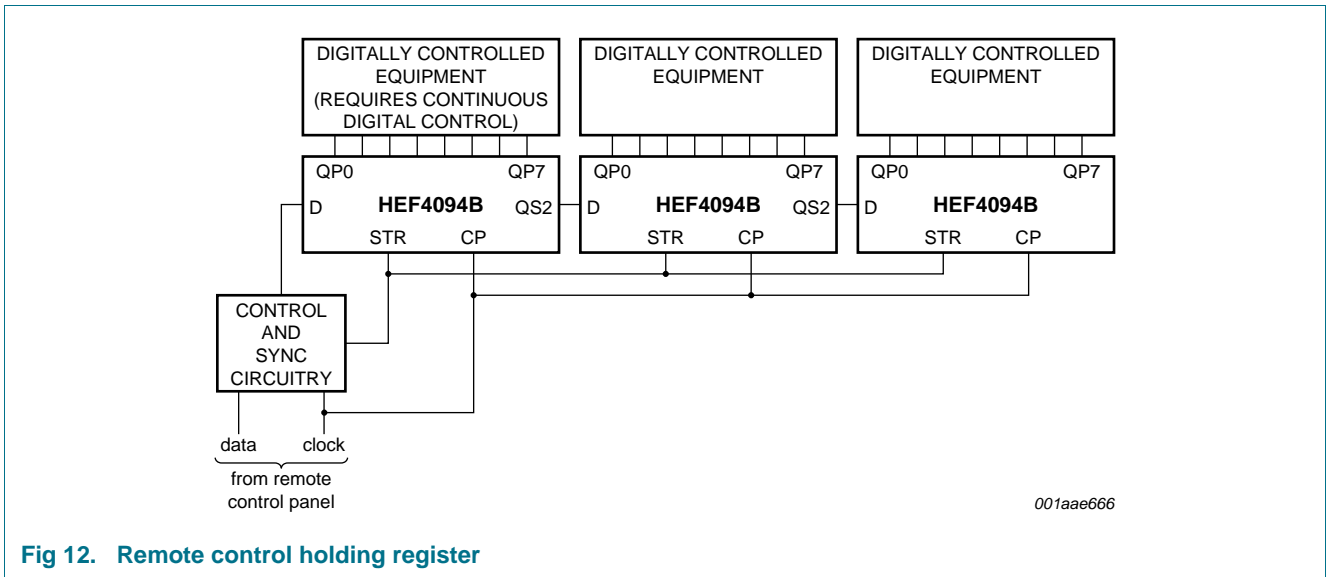

Fig 12. Remote control holding register

13. Package outline

DIP16: plastic dual in-line package; 16 leads (300 mil)

SOT38-4

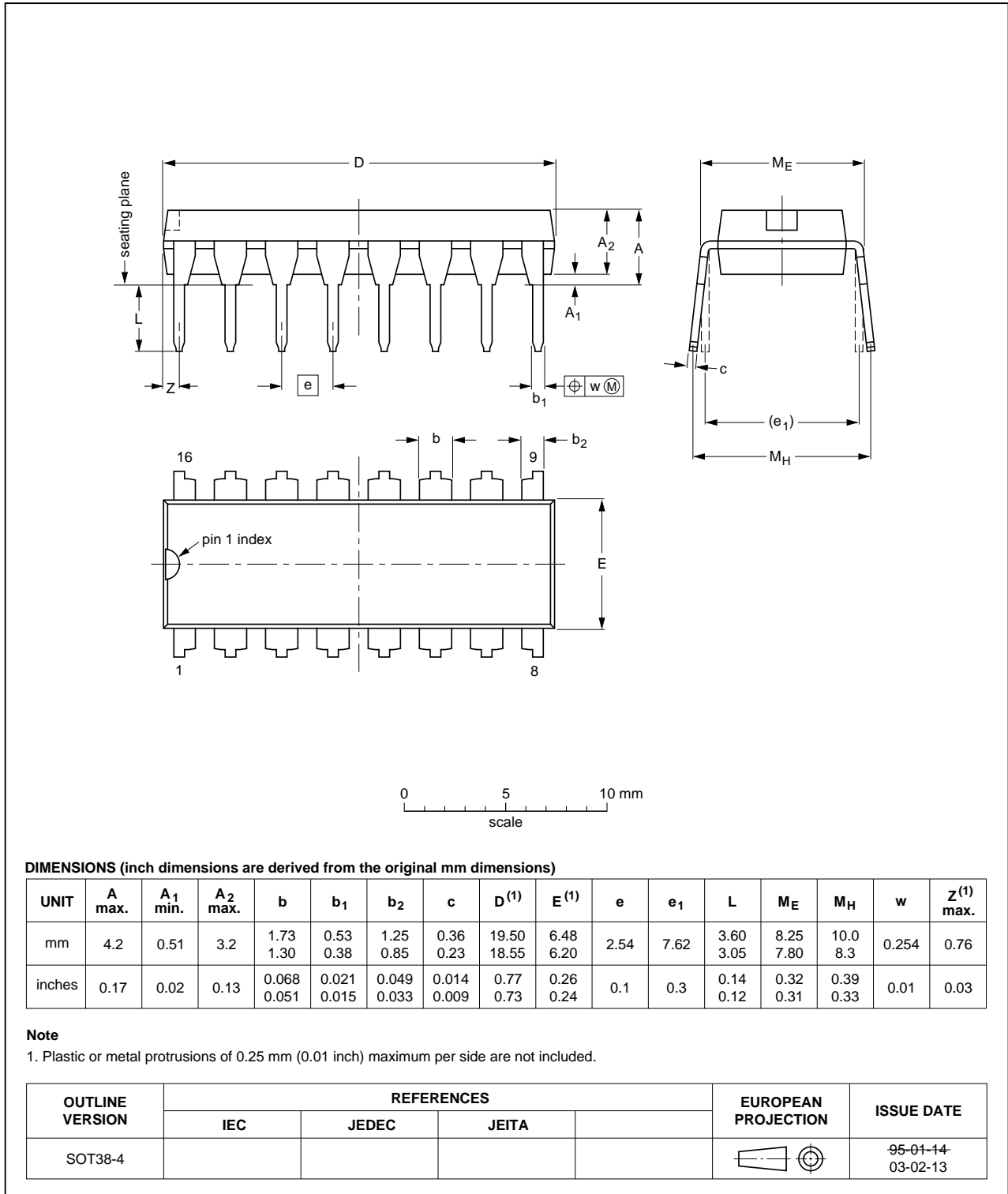

Fig 13. Package outline SOT38-4 (DIP16)

SO16: plastic small outline package; 16 leads; body width 3.9 mm

SOT109-1

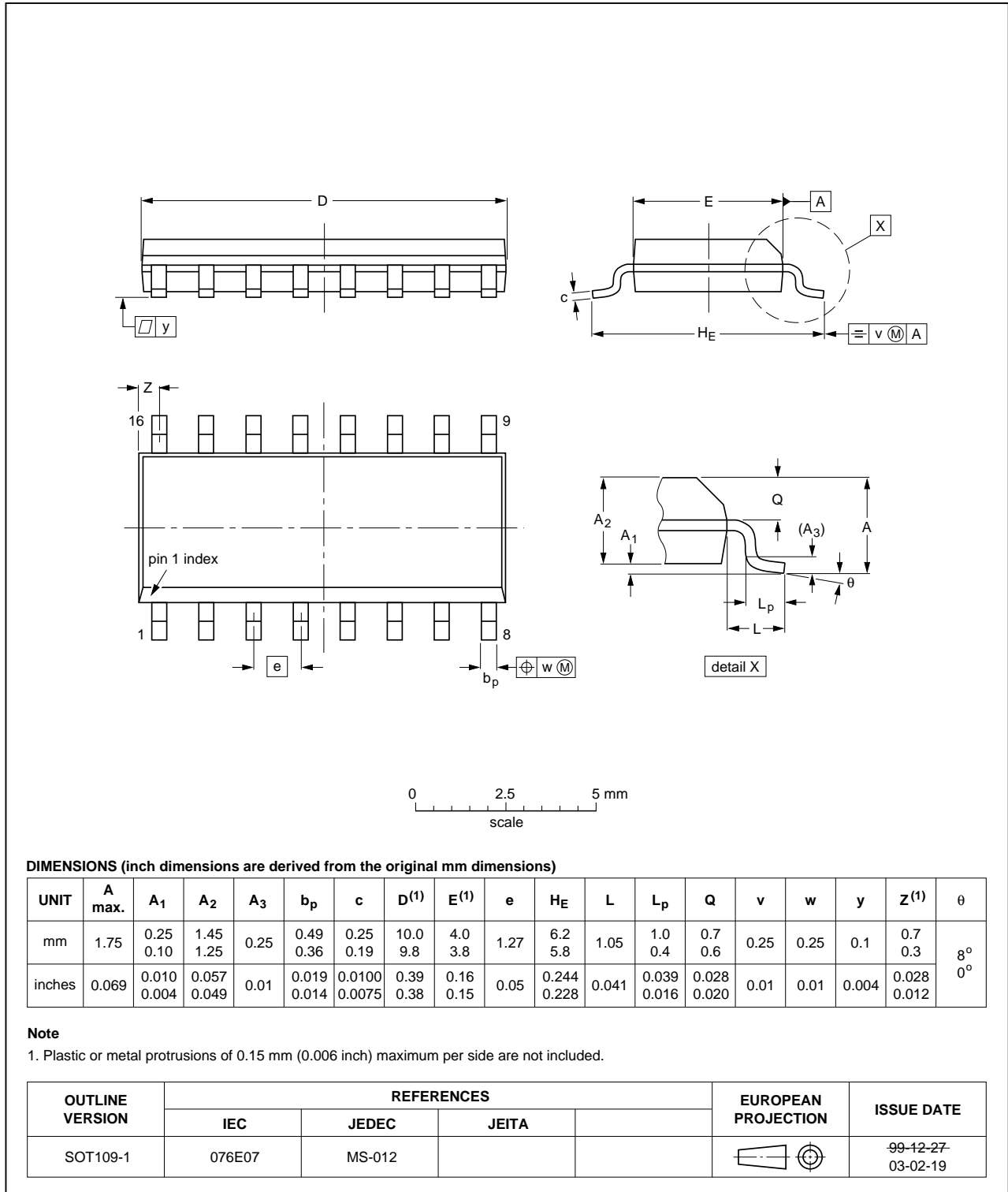

Fig 14. Package outline SOT109-1 (SO16)

SSOP16: plastic shrink small outline package; 16 leads; body width 5.3 mm

SOT338-1

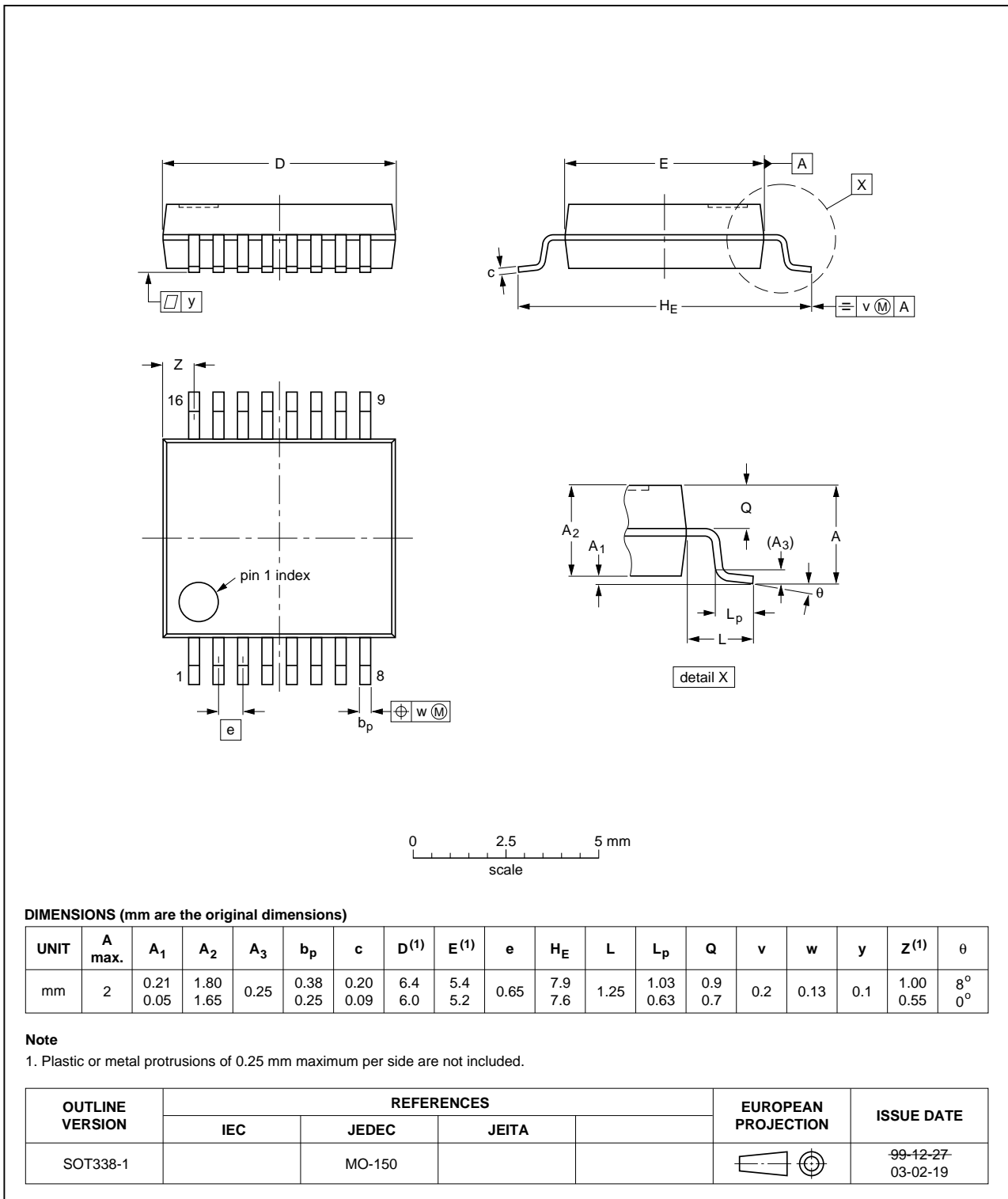

Fig 15. Package outline SOT338-1 (SSOP16)

TSSOP16: plastic thin shrink small outline package; 16 leads; body width 4.4 mm

SOT403-1

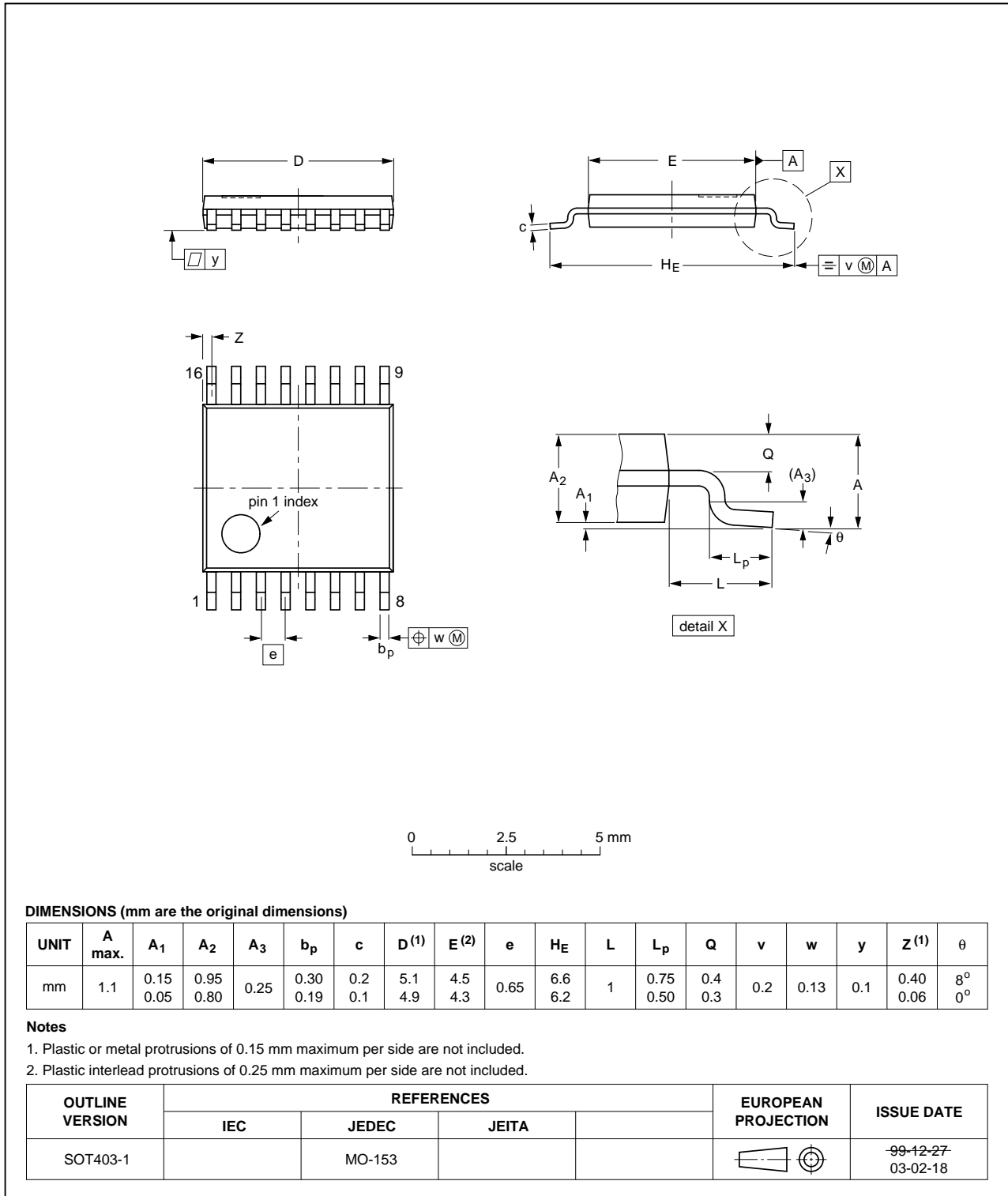

Fig 16. Package outline SOT403-1 (TSSOP16)

14. Revision history

Table 11. Revision history

Document ID	Release date	Data sheet status	Change notice	Supersedes
HEF4094B v.11	20130829	Product data sheet	-	HEF4094B v.10
Modifications:	<ul style="list-style-type: none"> • Table 4: Table note corrected (errata). 			
HEF4094B v.10	20130625	Product data sheet	-	HEF4094B v.9
Modifications:	<ul style="list-style-type: none"> • added type number HEF4094BTT. 			
HEF4094B v.9	20111116	Product data sheet	-	HEF4094B v.8
Modifications:	<ul style="list-style-type: none"> • Table 6: I_{OH} minimum values changed to maximum 			
HEF4094B v.8	20100402	Product data sheet	-	HEF4094B v.7
HEF4094B v.7	20091216	Product data sheet	-	HEF4094B v.6
HEF4094B v.6	20091103	Product data sheet	-	HEF4094B v.5
HEF4094B v.5	20090728	Product data sheet	-	HEF4094B v.4
HEF4094B v.4	20081030	Product data sheet	-	HEF4094B_CNV v.3
HEF4094B_CNV v.3	19950101	Product specification	-	HEF4094B_CNV v.2
HEF4094B_CNV v.2	19950101	Product specification	-	-

15. Legal information

15.1 Data sheet status

Document status ^{[1][2]}	Product status ^[3]	Definition
Objective [short] data sheet	Development	This document contains data from the objective specification for product development.
Preliminary [short] data sheet	Qualification	This document contains data from the preliminary specification.
Product [short] data sheet	Production	This document contains the product specification.

[1] Please consult the most recently issued document before initiating or completing a design.

[2] The term 'short data sheet' is explained in section "Definitions".

[3] The product status of device(s) described in this document may have changed since this document was published and may differ in case of multiple devices. The latest product status information is available on the Internet at URL <http://www.nxp.com>.

15.2 Definitions

Draft — The document is a draft version only. The content is still under internal review and subject to formal approval, which may result in modifications or additions. NXP Semiconductors does not give any representations or warranties as to the accuracy or completeness of information included herein and shall have no liability for the consequences of use of such information.

Short data sheet — A short data sheet is an extract from a full data sheet with the same product type number(s) and title. A short data sheet is intended for quick reference only and should not be relied upon to contain detailed and full information. For detailed and full information see the relevant full data sheet, which is available on request via the local NXP Semiconductors sales office. In case of any inconsistency or conflict with the short data sheet, the full data sheet shall prevail.

Product specification — The information and data provided in a Product data sheet shall define the specification of the product as agreed between NXP Semiconductors and its customer, unless NXP Semiconductors and customer have explicitly agreed otherwise in writing. In no event however, shall an agreement be valid in which the NXP Semiconductors product is deemed to offer functions and qualities beyond those described in the Product data sheet.

15.3 Disclaimers

Limited warranty and liability — Information in this document is believed to be accurate and reliable. However, NXP Semiconductors does not give any representations or warranties, expressed or implied, as to the accuracy or completeness of such information and shall have no liability for the consequences of use of such information. NXP Semiconductors takes no responsibility for the content in this document if provided by an information source outside of NXP Semiconductors.

In no event shall NXP Semiconductors be liable for any indirect, incidental, punitive, special or consequential damages (including - without limitation - lost profits, lost savings, business interruption, costs related to the removal or replacement of any products or rework charges) whether or not such damages are based on tort (including negligence), warranty, breach of contract or any other legal theory.

Notwithstanding any damages that customer might incur for any reason whatsoever, NXP Semiconductors' aggregate and cumulative liability towards customer for the products described herein shall be limited in accordance with the *Terms and conditions of commercial sale* of NXP Semiconductors.

Right to make changes — NXP Semiconductors reserves the right to make changes to information published in this document, including without limitation specifications and product descriptions, at any time and without notice. This document supersedes and replaces all information supplied prior to the publication hereof.

Suitability for use — NXP Semiconductors products are not designed, authorized or warranted to be suitable for use in life support, life-critical or safety-critical systems or equipment, nor in applications where failure or malfunction of an NXP Semiconductors product can reasonably be expected to result in personal injury, death or severe property or environmental damage. NXP Semiconductors and its suppliers accept no liability for inclusion and/or use of NXP Semiconductors products in such equipment or applications and therefore such inclusion and/or use is at the customer's own risk.

Applications — Applications that are described herein for any of these products are for illustrative purposes only. NXP Semiconductors makes no representation or warranty that such applications will be suitable for the specified use without further testing or modification.

Customers are responsible for the design and operation of their applications and products using NXP Semiconductors products, and NXP Semiconductors accepts no liability for any assistance with applications or customer product design. It is customer's sole responsibility to determine whether the NXP Semiconductors product is suitable and fit for the customer's applications and products planned, as well as for the planned application and use of customer's third party customer(s). Customers should provide appropriate design and operating safeguards to minimize the risks associated with their applications and products.

NXP Semiconductors does not accept any liability related to any default, damage, costs or problem which is based on any weakness or default in the customer's applications or products, or the application or use by customer's third party customer(s). Customer is responsible for doing all necessary testing for the customer's applications and products using NXP Semiconductors products in order to avoid a default of the applications and the products or of the application or use by customer's third party customer(s). NXP does not accept any liability in this respect.

Limiting values — Stress above one or more limiting values (as defined in the Absolute Maximum Ratings System of IEC 60134) will cause permanent damage to the device. Limiting values are stress ratings only and (proper) operation of the device at these or any other conditions above those given in the Recommended operating conditions section (if present) or the Characteristics sections of this document is not warranted. Constant or repeated exposure to limiting values will permanently and irreversibly affect the quality and reliability of the device.

Terms and conditions of commercial sale — NXP Semiconductors products are sold subject to the general terms and conditions of commercial sale, as published at <http://www.nxp.com/profile/terms>, unless otherwise agreed in a valid written individual agreement. In case an individual agreement is concluded only the terms and conditions of the respective agreement shall apply. NXP Semiconductors hereby expressly objects to applying the customer's general terms and conditions with regard to the purchase of NXP Semiconductors products by customer.

No offer to sell or license — Nothing in this document may be interpreted or construed as an offer to sell products that is open for acceptance or the grant, conveyance or implication of any license under any copyrights, patents or other industrial or intellectual property rights.

Export control — This document as well as the item(s) described herein may be subject to export control regulations. Export might require a prior authorization from competent authorities.

Non-automotive qualified products — Unless this data sheet expressly states that this specific NXP Semiconductors product is automotive qualified, the product is not suitable for automotive use. It is neither qualified nor tested in accordance with automotive testing or application requirements. NXP Semiconductors accepts no liability for inclusion and/or use of non-automotive qualified products in automotive equipment or applications.

In the event that customer uses the product for design-in and use in automotive applications to automotive specifications and standards, customer (a) shall use the product without NXP Semiconductors' warranty of the product for such automotive applications, use and specifications, and (b) whenever customer uses the product for automotive applications beyond

NXP Semiconductors' specifications such use shall be solely at customer's own risk, and (c) customer fully indemnifies NXP Semiconductors for any liability, damages or failed product claims resulting from customer design and use of the product for automotive applications beyond NXP Semiconductors' standard warranty and NXP Semiconductors' product specifications.

Translations — A non-English (translated) version of a document is for reference only. The English version shall prevail in case of any discrepancy between the translated and English versions.

15.4 Trademarks

Notice: All referenced brands, product names, service names and trademarks are the property of their respective owners.

16. Contact information

For more information, please visit: <http://www.nxp.com>

For sales office addresses, please send an email to: salesaddresses@nxp.com

17. Contents

1	General description	1
2	Features and benefits	1
3	Ordering information	1
4	Functional diagram	2
5	Pinning information	3
5.1	Pinning	3
5.2	Pin description	3
6	Functional description	4
7	Limiting values	5
8	Recommended operating conditions	5
9	Static characteristics	6
10	Dynamic characteristics	7
11	Waveforms	9
12	Application information	12
13	Package outline	13
14	Revision history	17
15	Legal information	18
15.1	Data sheet status	18
15.2	Definitions	18
15.3	Disclaimers	18
15.4	Trademarks	19
16	Contact information	19
17	Contents	20

Please be aware that important notices concerning this document and the product(s) described herein, have been included in section 'Legal information'.

© NXP B.V. 2013.

All rights reserved.

For more information, please visit: <http://www.nxp.com>

For sales office addresses, please send an email to: salesaddresses@nxp.com

Date of release: 29 August 2013

Document identifier: HEF4094B



LittleDiode supplies new, hard to find or obsolete electronic components and semiconductors all over the world.

With over two million different components listed you are sure to find the part you need.

Feel free to visit us today at our online store:

LittleDiode.com

Looking forward to providing you with the best possible service.