



# 3.3V CMOS 16-BIT EDGE-TRIGGERED D-TYPE FLIP- FLOP WITH 3-STATE OUTPUTS, 5 VOLT TOLERANT I/O

**IDT74LVC162374A**

## FEATURES:

- Typical  $t_{SK(O)}$  (Output Skew) < 250ps
- ESD > 2000V per MIL-STD-883, Method 3015; > 200V using machine model (C = 200pF, R = 0)
- $V_{CC} = 3.3V \pm 0.3V$ , Normal Range
- $V_{CC} = 2.7V$  to  $3.6V$ , Extended Range
- CMOS power levels (0.4 $\mu$ W typ. static)
- All inputs, outputs, and I/O are 5V tolerant
- Available in SSOP, TSSOP, and TVSOP packages

## DRIVE FEATURES:

- Balanced Output Drivers:  $\pm 12mA$
- Low switching noise

## APPLICATIONS:

- 5V and 3.3V mixed voltage systems
- Data communication and telecommunication systems

## DESCRIPTION:

The LVC162374A 16-bit edge-triggered D-type flip-flop is built using advanced dual metal CMOS technology. This high-speed, low-power register is ideal for use as a buffer register for data synchronization and storage. The output enable ( $\overline{OE}$ ) and clock (CLK) controls are organized to operate each device as two 8-bit registers or one 16-bit register with common clock. Flow-through organization of signal pins simplifies layout. All inputs are designed with hysteresis for improved noise margin.

All pins of the LVC162374A can be driven from either 3.3V or 5V devices. This feature allows the use of this device as a translator in a mixed 3.3V/5V supply system.

The LVC162374A has series resistors in the device output structure which will significantly reduce line noise when used with light loads. This driver has been developed to drive  $\pm 12mA$  at the designated thresholds.

## FUNCTIONAL BLOCK DIAGRAM

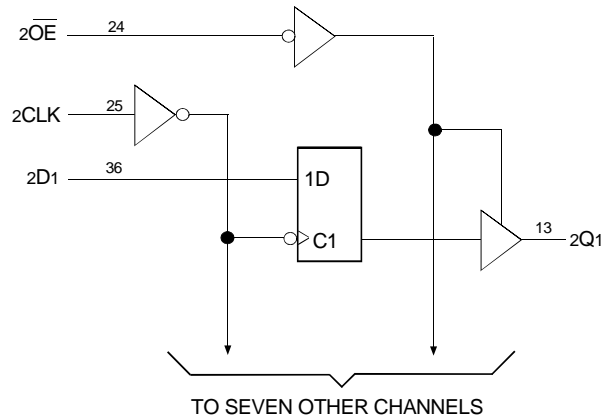
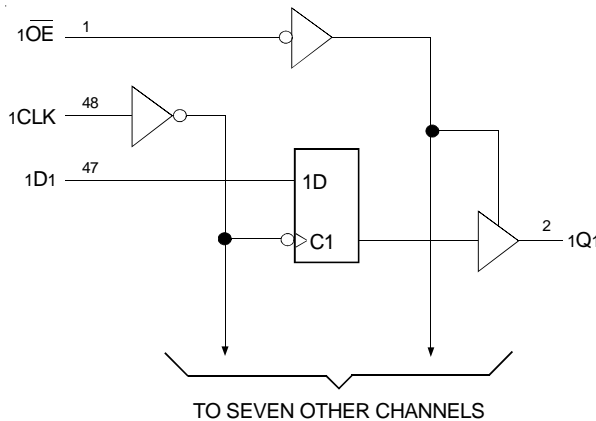

## PIN CONFIGURATION

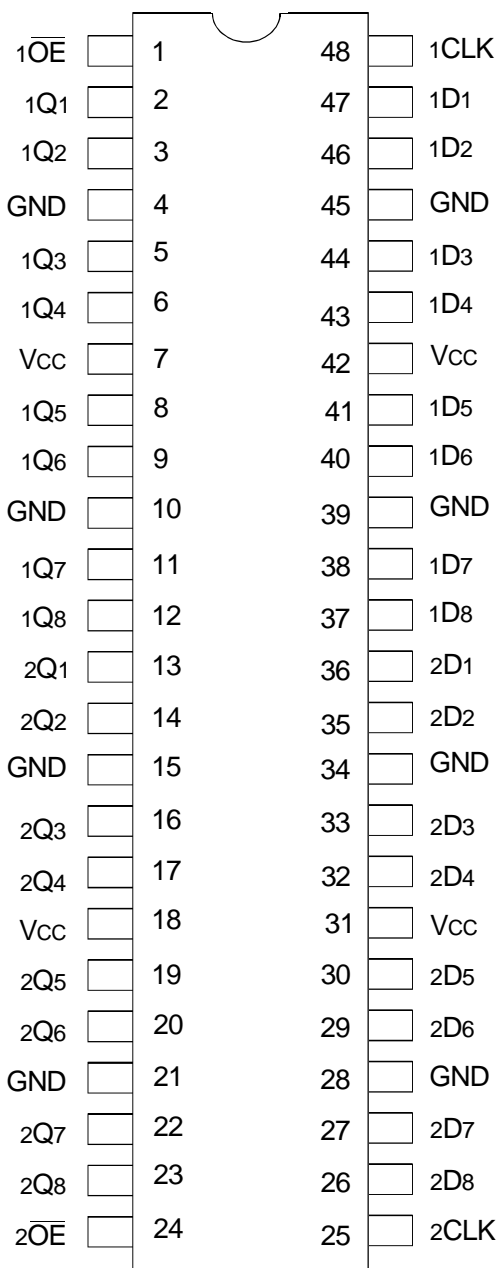

SSOP/ TSSOP/ TVSOP  
TOP VIEW

## ABSOLUTE MAXIMUM RATINGS<sup>(1)</sup>

Symbol	Description	Max	Unit
VTERM <sup>(2)</sup>	Terminal Voltage with Respect to GND	-0.5 to +6.5	V
VTERM <sup>(3)</sup>	Terminal Voltage with Respect to GND	-0.5 to +6.5	V
TSTG	Storage Temperature	-65 to +150	°C
IOUT	DC Output Current	-50 to +50	mA
IIK IOK	Continuous Clamp Current, VI < 0 or VO < 0	-50	mA
ICC ISS	Continuous Current through each VCC or GND	±100	mA

### NOTES:

- Stresses greater than those listed under ABSOLUTE MAXIMUM RATINGS may cause permanent damage to the device. This is a stress rating only and functional operation of the device at these or any other conditions above those indicated in the operational sections of this specification is not implied. Exposure to absolute maximum rating conditions for extended periods may affect reliability.
- VCC terminals.
- All terminals except VCC.

## CAPACITANCE (TA = +25°C, F = 1.0MHz)

Symbol	Parameter <sup>(1)</sup>	Conditions	Typ.	Max.	Unit
CIN	Input Capacitance	VIN = 0V	4.5	6	pF
COUT	Output Capacitance	VOUT = 0V	6.5	8	pF
C <sub>I/O</sub>	I/O Port Capacitance	VIN = 0V	6.5	8	pF

### NOTE:

- As applicable to the device type.

## PIN DESCRIPTION

Pin Names	Description
xDX	Data Inputs
xCLK	Clock Inputs
xQx	3-State Outputs
xOE	3-State Output Enable Inputs (Active LOW)

## FUNCTION TABLE (EACH FLIP-FLOP)<sup>(1)</sup>

Inputs			Outputs
xOE	xCLK	xDx	xQx
L	↑	H	H
L	↑	L	L
L	H or L	X	Q <sup>(2)</sup>
H	X	X	Z

### NOTES:

- H = HIGH Voltage Level  
X = Don't Care  
L = LOW Voltage Level  
Z = High-Impedance
- Output level before the indicated steady-state input conditions were established.

## DC ELECTRICAL CHARACTERISTICS OVER OPERATING RANGE

Following Conditions Apply Unless Otherwise Specified:

Operating Condition:  $T_A = -40^{\circ}\text{C}$  to  $+85^{\circ}\text{C}$

Symbol	Parameter	Test Conditions		Min.	Typ. <sup>(1)</sup>	Max.	Unit
V <sub>IH</sub>	Input HIGH Voltage Level	V <sub>CC</sub> = 2.3V to 2.7V		1.7	—	—	V
		V <sub>CC</sub> = 2.7V to 3.6V		2	—	—	
V <sub>IL</sub>	Input LOW Voltage Level	V <sub>CC</sub> = 2.3V to 2.7V		—	—	0.7	V
		V <sub>CC</sub> = 2.7V to 3.6V		—	—	0.8	
I <sub>IH</sub> I <sub>IL</sub>	Input Leakage Current	V <sub>CC</sub> = 3.6V	V <sub>I</sub> = 0 to 5.5V	—	—	±5	μA
I <sub>OZH</sub> I <sub>OZL</sub>	High Impedance Output Current (3-State Output pins)	V <sub>CC</sub> = 3.6V	V <sub>O</sub> = 0 to 5.5V	—	—	±10	μA
I <sub>OFF</sub>	Input/Output Power Off Leakage	V <sub>CC</sub> = 0V, V <sub>IN</sub> or V <sub>O</sub> ≤ 5.5V		—	—	±50	μA
V <sub>IK</sub>	Clamp Diode Voltage	V <sub>CC</sub> = 2.3V, I <sub>IN</sub> = -18mA		—	-0.7	-1.2	V
V <sub>H</sub>	Input Hysteresis	V <sub>CC</sub> = 3.3V		—	100	—	mV
I <sub>CCL</sub> I <sub>CCH</sub> I <sub>CCZ</sub>	Quiescent Power Supply Current	V <sub>CC</sub> = 3.6V	V <sub>IN</sub> = GND or V <sub>CC</sub>	—	—	10	μA
			3.6 ≤ V <sub>IN</sub> ≤ 5.5V <sup>(2)</sup>	—	—	10	
ΔI <sub>CC</sub>	Quiescent Power Supply Current Variation	One input at V <sub>CC</sub> - 0.6V, other inputs at V <sub>CC</sub> or GND		—	—	500	μA

### NOTES:

1. Typical values are at V<sub>CC</sub> = 3.3V, +25°C ambient.
2. This applies in the disabled state only.

## OUTPUT DRIVE CHARACTERISTICS

Symbol	Parameter	Test Conditions <sup>(1)</sup>		Min.	Max.	Unit
V <sub>OH</sub>	Output HIGH Voltage	V <sub>CC</sub> = 2.3V to 3.6V	I <sub>OH</sub> = -0.1mA	V <sub>CC</sub> - 0.2	—	V
		V <sub>CC</sub> = 2.3V	I <sub>OH</sub> = -4mA	1.9	—	
			I <sub>OH</sub> = -6mA	1.7	—	
		V <sub>CC</sub> = 2.7V	I <sub>OH</sub> = -4mA	2.2	—	
			I <sub>OH</sub> = -8mA	2	—	
		V <sub>CC</sub> = 3V	I <sub>OH</sub> = -6mA	2.4	—	
I <sub>OH</sub> = -12mA	2		—			
V <sub>OL</sub>	Output LOW Voltage	V <sub>CC</sub> = 2.3V to 3.6V	I <sub>OL</sub> = 0.1mA	—	0.2	V
		V <sub>CC</sub> = 2.3V	I <sub>OL</sub> = 4mA	—	0.4	
			I <sub>OL</sub> = 6mA	—	0.55	
		V <sub>CC</sub> = 2.7V	I <sub>OL</sub> = 4mA	—	0.4	
			I <sub>OL</sub> = 8mA	—	0.6	
		V <sub>CC</sub> = 3V	I <sub>OL</sub> = 6mA	—	0.55	
I <sub>OL</sub> = 12mA	—		0.8			

### NOTE:

1. V<sub>IH</sub> and V<sub>IL</sub> must be within the min. or max. range shown in the DC ELECTRICAL CHARACTERISTICS OVER OPERATING RANGE table for the appropriate V<sub>CC</sub> range. T<sub>A</sub> = -40°C to +85°C.

OPERATING CHARACTERISTICS,  $V_{CC} = 3.3V \pm 0.3V$ ,  $T_A = 25^\circ C$

Symbol	Parameter	Test Conditions	Typical	Unit
CPD	Power Dissipation Capacitance per Flip-Flop Outputs enabled	$C_L = 0pF$ , $f = 10MHz$	—	pF
CPD	Power Dissipation Capacitance per Flip-Flop Outputs disabled		—	

SWITCHING CHARACTERISTICS<sup>(1)</sup>

Symbol	Parameter	$V_{CC} = 2.7V$		$V_{CC} = 3.3V \pm 0.3V$		Unit
		Min.	Max.	Min.	Max.	
$t_{PLH}$ $t_{PHL}$	Propagation Delay xCLK to xQx	2	6.5	2	6.2	ns
$t_{PZH}$ $t_{PZL}$	Output Enable Time x $\overline{OE}$ to xQx	1.5	6.3	1.5	6.1	ns
$t_{PHZ}$ $t_{PLZ}$	Output Disable Time x $\overline{OE}$ to xQx	1.5	6.2	1.5	6	ns
$t_{SU}$	Set-up Time HIGH or LOW, xDx before xCLK $\uparrow$	2.5	—	2.5	—	ns
$t_H$	Hold Time HIGH or LOW, xDx after xCLK $\uparrow$	1.5	—	1.5	—	ns
$t_W$	xCLK Pulse Width HIGH or LOW	3	—	3	—	ns
$t_{SK(0)}$	Output Skew <sup>(2)</sup>	—	—	—	500	ps

NOTES:

1. See TEST CIRCUITS AND WAVEFORMS.  $T_A = -40^\circ C$  to  $+85^\circ C$ .
2. Skew between any two outputs of the same package and switching in the same direction.

## TEST CIRCUITS AND WAVEFORMS

### TEST CONDITIONS

Symbol	V <sub>CC</sub> <sup>(1)</sup> =3.3V±0.3V	V <sub>CC</sub> <sup>(1)</sup> =2.7V	V <sub>CC</sub> <sup>(2)</sup> =2.5V±0.2V	Unit
V <sub>LOAD</sub>	6	6	2 x V <sub>CC</sub>	V
V <sub>IH</sub>	2.7	2.7	V <sub>CC</sub>	V
V <sub>T</sub>	1.5	1.5	V <sub>CC</sub> / 2	V
V <sub>LZ</sub>	300	300	150	mV
V <sub>HZ</sub>	300	300	150	mV
C <sub>L</sub>	50	50	30	pF

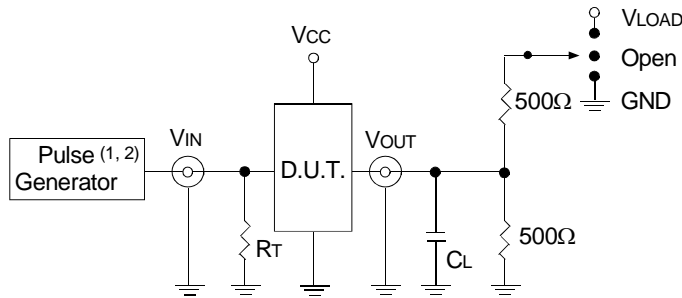

Test Circuit for All Outputs

#### DEFINITIONS:

C<sub>L</sub> = Load capacitance: includes jig and probe capacitance.  
R<sub>T</sub> = Termination resistance: should be equal to Z<sub>OUT</sub> of the Pulse Generator.

#### NOTES:

1. Pulse Generator for All Pulses: Rate ≤ 10MHz; t<sub>F</sub> ≤ 2.5ns; t<sub>R</sub> ≤ 2.5ns.
2. Pulse Generator for All Pulses: Rate ≤ 10MHz; t<sub>F</sub> ≤ 2ns; t<sub>R</sub> ≤ 2ns.

### SWITCH POSITION

Test	Switch
Open Drain Disable Low Enable Low	V <sub>LOAD</sub>
Disable High Enable High	GND
All Other Tests	Open

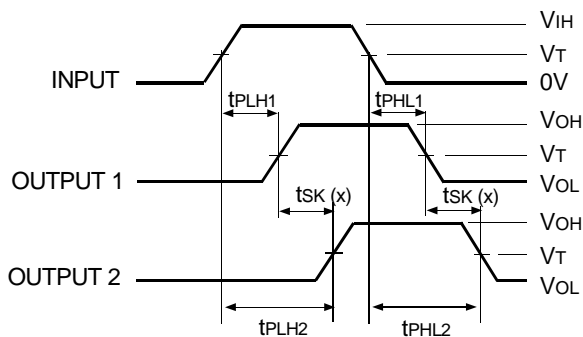

$$tsk(x) = |t_{PLH2} - t_{PLH1}| \text{ or } |t_{PHL2} - t_{PHL1}|$$

Output Skew - tsk(x)

#### NOTES:

1. For tsk(o) OUTPUT1 and OUTPUT2 are any two outputs.
2. For tsk(b) OUTPUT1 and OUTPUT2 are in the same bank.

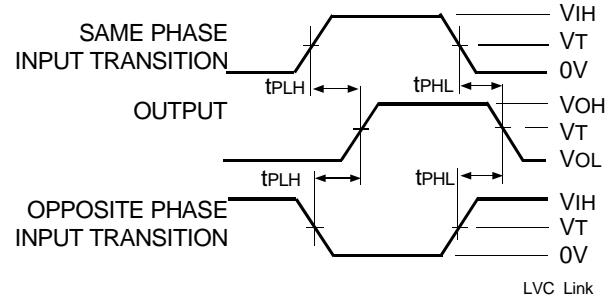

#### Propagation Delay

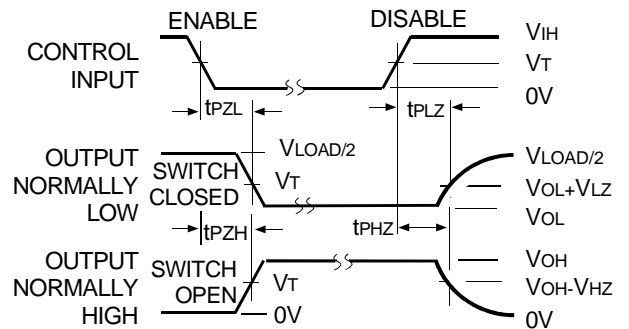

#### Enable and Disable Times

#### NOTE:

1. Diagram shown for input Control Enable-LOW and input Control Disable-HIGH.

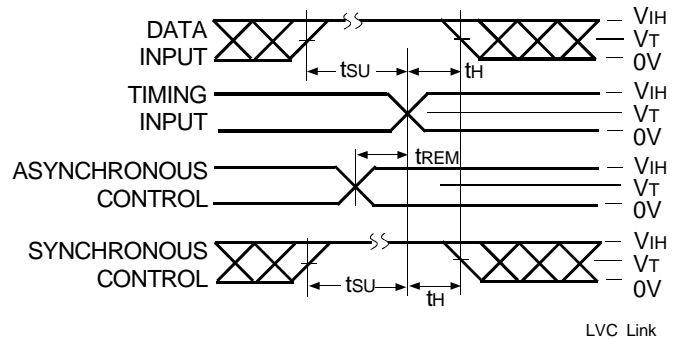

#### Set-up, Hold, and Release Times

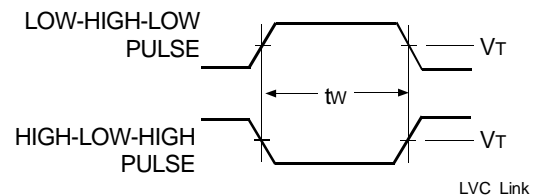

#### Pulse Width

## ORDERING INFORMATION

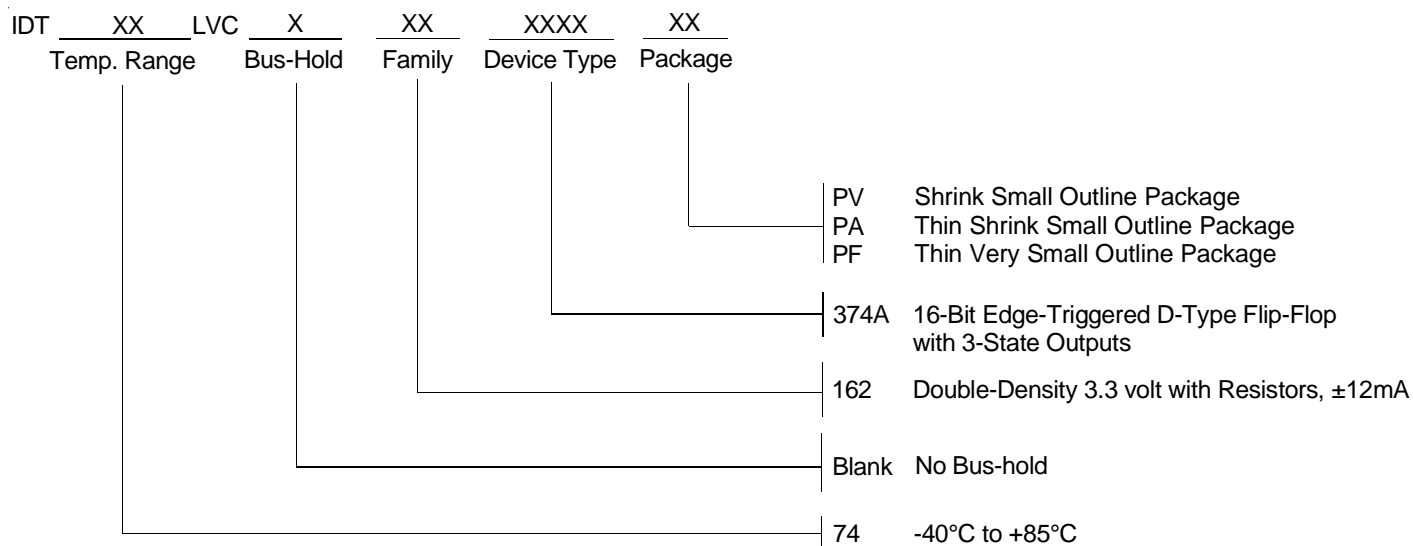

**CORPORATE HEADQUARTERS**  
 2975 Stender Way  
 Santa Clara, CA 95054

**for SALES:**  
 800-345-7015 or 408-727-6116  
 fax: 408-492-8674  
 www.idt.com

**for Tech Support:**  
 logichelp@idt.com  
 (408) 654-6459



LittleDiode supplies new, hard to find or obsolete electronic components and semiconductors all over the world.

With over two million different components listed you are sure to find the part you need.

Feel free to visit us today at our online store:

[LittleDiode.com](http://LittleDiode.com)

Looking forward to providing you with the best possible service.