



**ADS7806**

## Low-Power 12-Bit Sampling CMOS ANALOG-to-DIGITAL CONVERTER

### FEATURES

- 35mW max POWER DISSIPATION
- 50 $\mu$ W POWER DOWN MODE
- 25 $\mu$ s max ACQUISITION AND CONVERSION
- $\pm 1/2$ LSB max INL AND DNL
- 72dB min SINAD WITH 1kHz INPUT
- $\pm 10$ V, 0V TO +5V, AND 0V TO +4V INPUT RANGES
- SINGLE +5V SUPPLY OPERATION
- PARALLEL AND SERIAL DATA OUTPUT
- PIN-COMPATIBLE WITH 16-BIT ADS7807
- USES INTERNAL OR EXTERNAL REFERENCE
- 28-PIN 0.3" PLASTIC DIP AND SOIC

### DESCRIPTION

The ADS7806 is a low-power 12-bit sampling analog-to-digital using state-of-the-art CMOS structures. It contains a complete 12-bit, capacitor-based, SAR A/D with S/H, clock, reference, and microprocessor interface with parallel and serial output drivers.

The ADS7806 can acquire and convert to full 12-bit accuracy in 25 $\mu$ s max while consuming only 35mW max. Laser-trimmed scaling resistors provide standard industrial input ranges of  $\pm 10$ V and 0V to +5V. In addition, a 0V to +4V range allows development of complete single supply systems.

The 28-pin ADS7806 is available in a plastic 0.3" DIP and in an SOIC, both fully specified for operation over the industrial  $-40^{\circ}\text{C}$  to  $+85^{\circ}\text{C}$  temperature range.

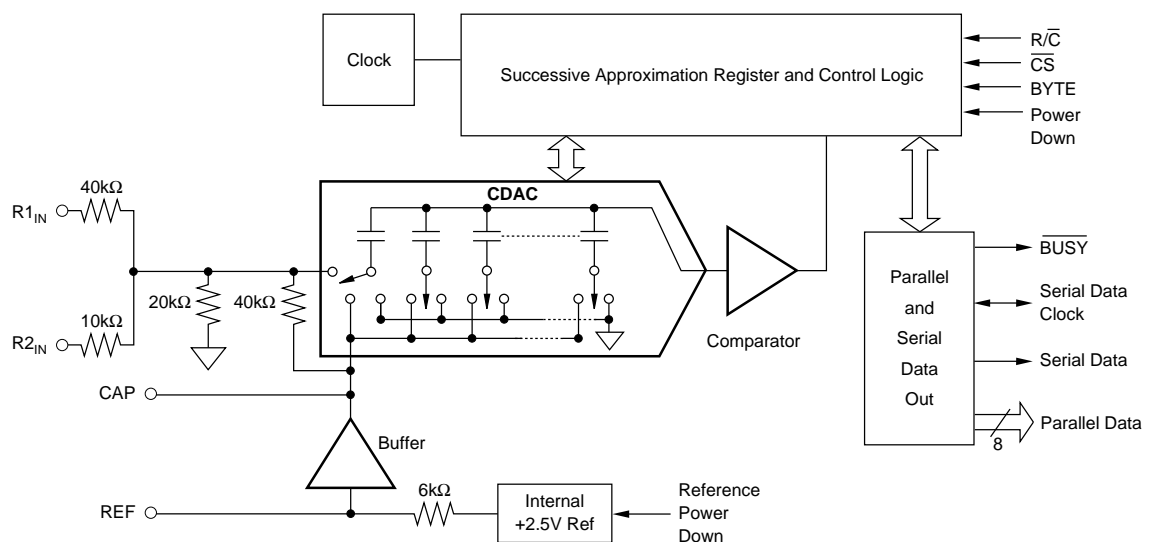

International Airport Industrial Park • Mailing Address: PO Box 11400 • Tucson, AZ 85734 • Street Address: 6730 S. Tucson Blvd. • Tucson, AZ 85706  
 Tel: (520) 746-1111 • Twx: 910-952-1111 • Cable: BBRCORP • Telex: 066-6491 • FAX: (520) 889-1510 • Immediate Product Info: (800) 548-6132



# SPECIFICATIONS (CONT)

## ELECTRICAL

At  $T_A = -40^{\circ}\text{C}$  to  $+85^{\circ}\text{C}$ ,  $f_S = 40\text{kHz}$ ,  $V_{\text{DIG}} = V_{\text{ANA}} = +5\text{V}$ , using internal reference and fixed resistors shown in Figure 7b, unless otherwise specified.

PARAMETER	CONDITIONS	ADS7806P, U			ADS7806PB, UB			UNITS
		MIN	TYP	MAX	MIN	TYP	MAX	
<b>DIGITAL TIMING</b>								
Bus Access Time	$R_L = 3.3\text{k}\Omega$ , $C_L = 50\text{pF}$			83			*	ns
Bus Relinquish Time	$R_L = 3.3\text{k}\Omega$ , $C_L = 10\text{pF}$			83			*	ns
<b>POWER SUPPLIES</b>								
Specified Performance	Must be $\leq V_{\text{ANA}}$	+4.75	+5	+5.25	*	*	*	V
$V_{\text{DIG}}$		+4.75	+5	+5.25	*	*	*	V
$V_{\text{ANA}}$			0.6			*		mA
$I_{\text{DIG}}$			5.0			*		mA
$I_{\text{ANA}}$			28	35		*	*	mW
Power Dissipation	$V_{\text{ANA}} = V_{\text{DIG}} = 5\text{V}$ , $f_S = 40\text{kHz}$ REFD HIGH PWRD and REFD HIGH		23			*	*	mW
			50			*	*	$\mu\text{W}$
<b>TEMPERATURE RANGE</b>								
Specified Performance		-40		+85	*		*	$^{\circ}\text{C}$
Derated Performance		-55		+125	*		*	$^{\circ}\text{C}$
Storage		-65		+150	*		*	$^{\circ}\text{C}$
Thermal Resistance ( $\theta_{\text{JA}}$ )								
Plastic DIP			75			*		$^{\circ}\text{C}/\text{W}$
SOIC			75			*		$^{\circ}\text{C}/\text{W}$

NOTES: (1) LSB means Least Significant Bit. One LSB for the  $\pm 10\text{V}$  input range is  $4.88\text{mV}$ . (2) Typical rms noise at worst case transition. (3) As measured with fixed resistors shown in Figure 7b. Adjustable to zero with external potentiometer. (4) Full scale error is the worst case of -Full Scale or +Full Scale untrimmed deviation from ideal first and last code transitions, divided by the transition voltage (not divided by the full-scale range) and includes the effect of offset error. (5) This is the time delay after the ADS7806 is brought out of Power Down Mode until all internal settling occurs and the analog input is acquired to rated accuracy. A Convert Command after this delay will yield accurate results. (6) All specifications in dB are referred to a full-scale input. (7) Usable Bandwidth defined as Full-Scale input frequency at which Signal-to-(Noise + Distortion) degrades to  $60\text{dB}$ . (8) Recovers to specified performance after  $2 \times \text{FS}$  input overvoltage.

## ABSOLUTE MAXIMUM RATINGS

Analog Inputs: $R_{1\text{IN}}$ .....	$\pm 25\text{V}$
$R_{2\text{IN}}$ .....	$\pm 25\text{V}$
CAP .....	$V_{\text{ANA}} + 0.3\text{V}$ to AGND2 - $0.3\text{V}$
REF .....	Indefinite Short to AGND2, Momentary Short to $V_{\text{ANA}}$
Ground Voltage Differences: DGND, AGND1, and AGND2 .....	$\pm 0.3\text{V}$
$V_{\text{ANA}}$ .....	7V
$V_{\text{DIG}}$ to $V_{\text{ANA}}$ .....	+ $0.3\text{V}$
$V_{\text{DIG}}$ .....	7V
Digital Inputs .....	- $0.3\text{V}$ to $V_{\text{DIG}} + 0.3\text{V}$
Maximum Junction Temperature .....	+ $165^{\circ}\text{C}$
Internal Power Dissipation .....	825mW
Lead Temperature (soldering, 10s) .....	+ $300^{\circ}\text{C}$

## ELECTROSTATIC DISCHARGE SENSITIVITY

Electrostatic discharge can cause damage ranging from performance degradation to complete device failure. Burr-Brown Corporation recommends that this integrated circuit be handled and stored using appropriate ESD protection methods.

## ORDERING INFORMATION

MODEL	MAXIMUM INTEGRAL LINEARITY ERROR (LSB)	MINIMUM SIGNAL-TO-(NOISE + DISTORTION) RATIO (dB)	SPECIFICATION TEMPERATURE RANGE	PACKAGE
ADS7806P	$\pm 0.9$	70	$-40^{\circ}\text{C}$ to $+85^{\circ}\text{C}$	Plastic DIP
ADS7806PB	$\pm 0.45$	72	$-40^{\circ}\text{C}$ to $+85^{\circ}\text{C}$	Plastic DIP
ADS7806U	$\pm 0.9$	70	$-40^{\circ}\text{C}$ to $+85^{\circ}\text{C}$	SOIC
ADS7806UB	$\pm 0.45$	72	$-40^{\circ}\text{C}$ to $+85^{\circ}\text{C}$	SOIC

## PACKAGE INFORMATION

MODEL	PACKAGE	PACKAGE DRAWING NUMBER <sup>(1)</sup>
ADS7806P	Plastic DIP	246
ADS7806PB	Plastic DIP	246
ADS7806U	SOIC	217
ADS7806UB	SOIC	217

NOTE: (1) For detailed drawing and dimension table, please see end of data sheet, or Appendix D of Burr-Brown IC Data Book.

PIN #	NAME	DIGITAL I/O	DESCRIPTION
1	R1 <sub>IN</sub>		Analog Input. See Figure 7.
2	AGND1		Analog Sense Ground.
3	R2 <sub>IN</sub>		Analog Input. See Figure 7.
4	CAP		Reference Buffer Output. 2.2μF tantalum capacitor to ground.
5	REF		Reference Input/Output. 2.2μF tantalum capacitor to ground.
6	AGND2		Analog Ground.
7	SB/BTC	I	Selects Straight Binary or Binary Two's Complement for Output Data Format.
8	EXT/INT	I	External/Internal data clock select.
9	D7	O	Data Bit 3 if BYTE is HIGH. Data bit 11 (MSB) if BYTE is LOW. Hi-Z when $\overline{CS}$ is HIGH and/or $R/\overline{C}$ is LOW. Leave unconnected when using serial output.
10	D6	O	Data Bit 2 if BYTE is HIGH. Data bit 10 if BYTE is LOW. Hi-Z when $\overline{CS}$ is HIGH and/or $R/\overline{C}$ is LOW.
11	D5	O	Data Bit 1 if BYTE is HIGH. Data bit 9 if BYTE is LOW. Hi-Z when $\overline{CS}$ is HIGH and/or $R/\overline{C}$ is LOW.
12	D4	O	Data Bit 0 (LSB) if BYTE is HIGH. Data bit 8 if BYTE is LOW. Hi-Z when $\overline{CS}$ is HIGH and/or $R/\overline{C}$ is LOW.
13	D3	O	LOW if BYTE is HIGH. Data bit 7 if BYTE is LOW. Hi-Z when $\overline{CS}$ is HIGH and/or $R/\overline{C}$ is LOW.
14	DGND		Digital Ground.
15	D2	O	LOW if BYTE is HIGH. Data bit 6 if BYTE is LOW. Hi-Z when $\overline{CS}$ is HIGH and/or $R/\overline{C}$ is LOW.
16	D1	O	LOW if BYTE is HIGH. Data bit 5 if BYTE is LOW. Hi-Z when $\overline{CS}$ is HIGH and/or $R/\overline{C}$ is LOW.
17	D0	O	LOW if BYTE is HIGH. Data bit 4 if BYTE is LOW. Hi-Z when $\overline{CS}$ is HIGH and/or $R/\overline{C}$ is LOW.
18	DATACLK	I/O	Data Clock Output when EXT/INT is LOW. Data clock input when EXT/INT is HIGH.
19	SDATA	O	Serial Output Synchronized to DATACLK.
20	TAG	I	Serial Input When Using an External Data Clock.
21	BYTE	I	Selects 8 most significant bits (LOW) or 4 least significant bits (HIGH) on parallel output pins.
22	R/ $\overline{C}$	I	With $\overline{CS}$ LOW and $\overline{BUSY}$ HIGH, a Falling Edge on $R/\overline{C}$ Initiates a New Conversion. With $\overline{CS}$ LOW, a rising edge on $R/\overline{C}$ enables the parallel output.
23	$\overline{CS}$	I	Internally OR'd with $R/\overline{C}$ . If $R/\overline{C}$ is LOW, a falling edge on $\overline{CS}$ initiates a new conversion. If EXT/INT is LOW, this same falling edge will start the transmission of serial data results from the previous conversion.
24	$\overline{BUSY}$	O	At the start of a conversion, $\overline{BUSY}$ goes LOW and stays LOW until the conversion is completed and the digital outputs have been updated.
25	PWRD	I	PWRD HIGH shuts down all analog circuitry except the reference. Digital circuitry remains active.
26	REFD	I	REFD HIGH shuts down the internal reference. External reference will be required for conversions.
27	V <sub>ANA</sub>		Analog Supply. Nominally +5V. Decouple with 0.1μF ceramic and 10μF tantalum capacitors.
28	V <sub>DIG</sub>		Digital Supply. Nominally +5V. Connect directly to pin 27. Must be $\leq V_{ANA}$ .

TABLE I. Pin Assignments.

## PIN CONFIGURATION

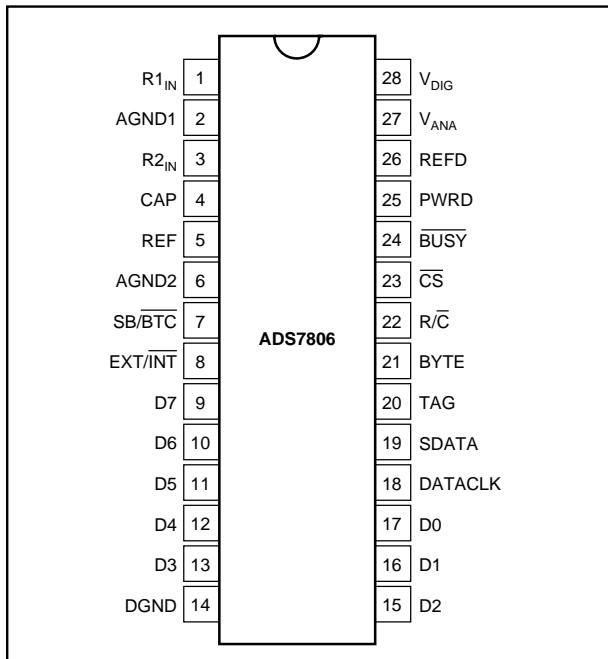

ANALOG INPUT RANGE	CONNECT R1 <sub>IN</sub> VIA 200Ω TO	CONNECT R2 <sub>IN</sub> VIA 100Ω TO	IMPEDANCE
±10V	V <sub>IN</sub>	CAP	45.7kΩ
0V to 5V	AGND	V <sub>IN</sub>	20.0kΩ
0V to 4V	V <sub>IN</sub>	V <sub>IN</sub>	21.4kΩ

TABLE II. Input Range Connections. See also Figure 7.

# TYPICAL PERFORMANCE CURVES

$T_A = +25^\circ\text{C}$ ,  $f_S = 40\text{kHz}$ ,  $V_{\text{DIG}} = V_{\text{ANA}} = +5\text{V}$ , using internal reference and fixed resistors shown in Figure 7b, unless otherwise specified.

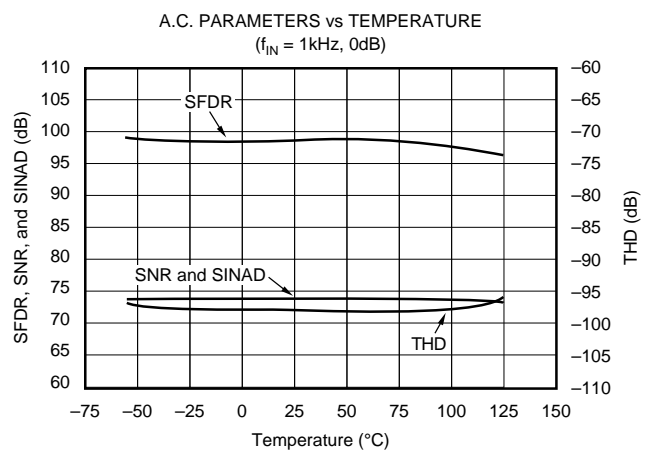
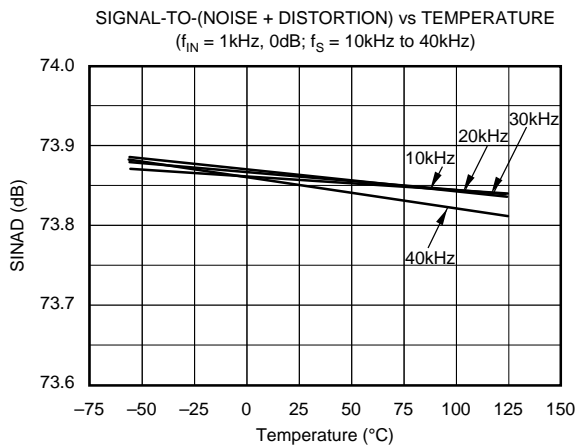
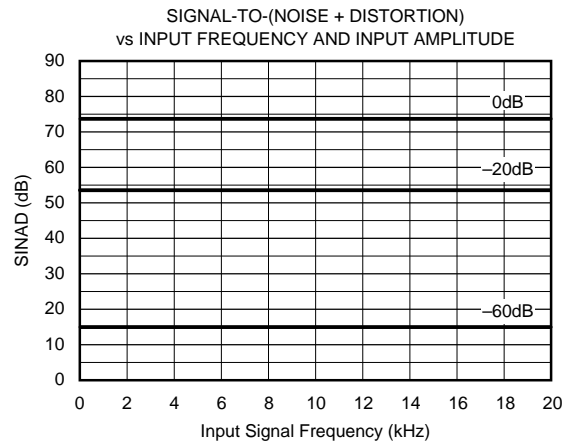
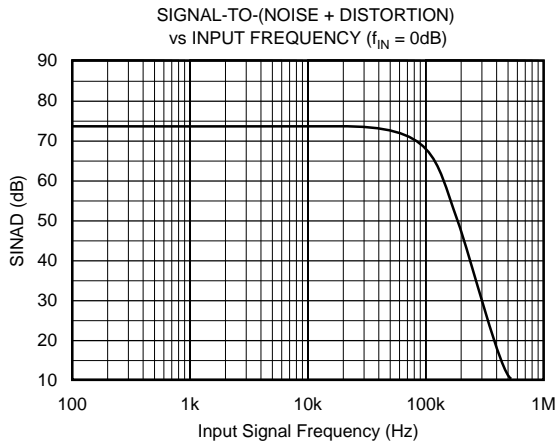
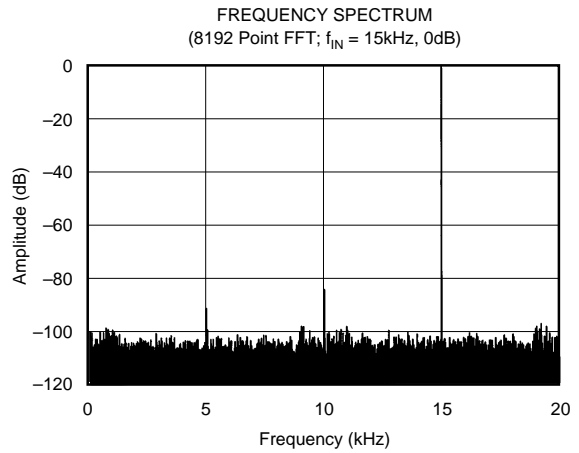
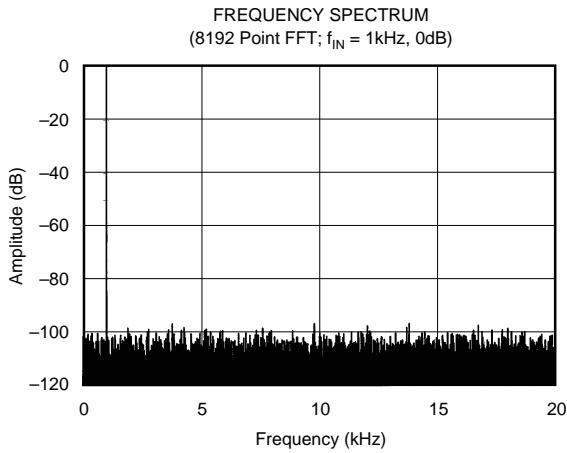

# TYPICAL PERFORMANCE CURVES (CONT)

$T_A = +25^\circ\text{C}$ ,  $f_S = 40\text{kHz}$ ,  $V_{\text{DIG}} = V_{\text{ANA}} = +5\text{V}$ , using internal reference and fixed resistors shown in Figure 7b, unless otherwise specified.

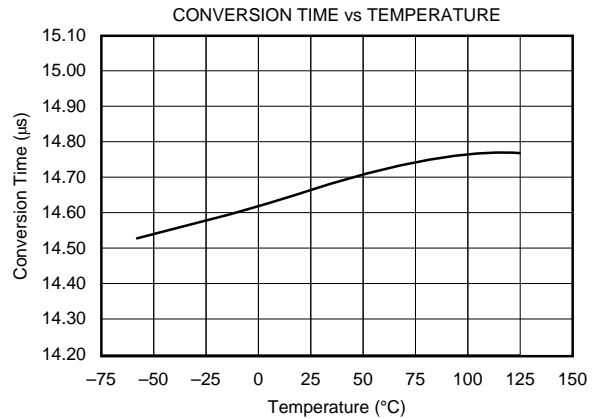
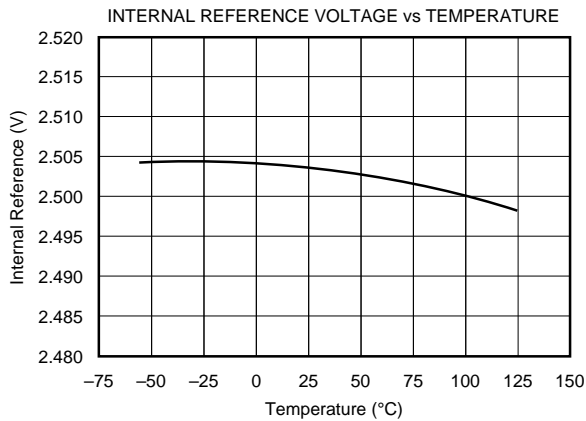
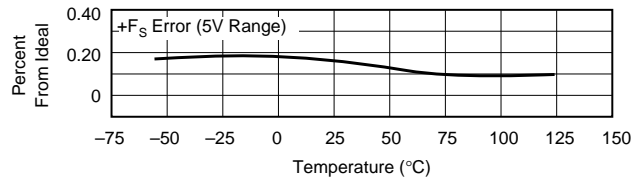
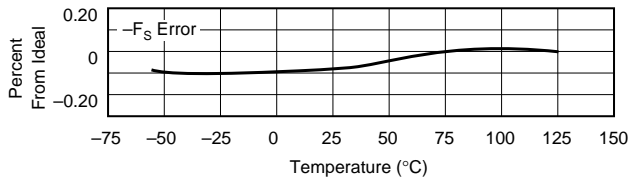
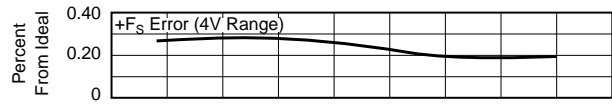
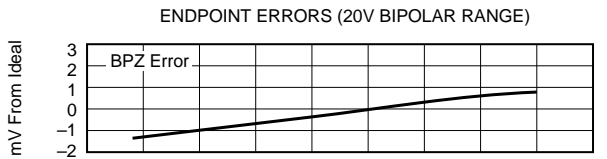
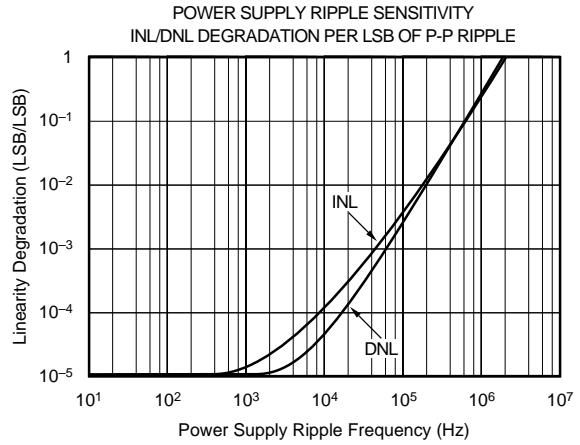
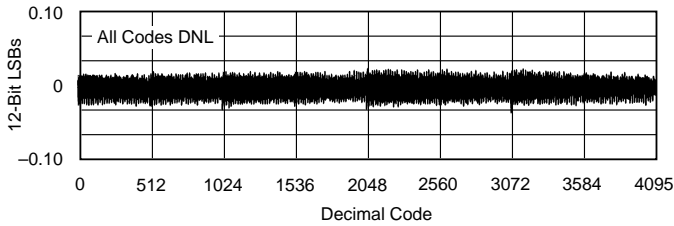
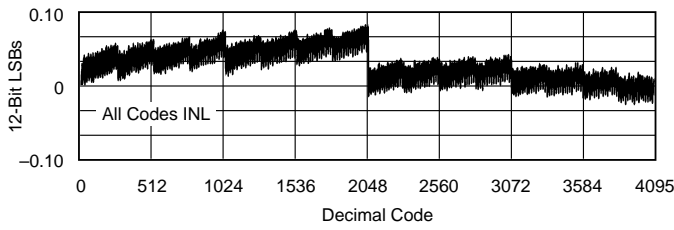

# BASIC OPERATION

## PARALLEL OUTPUT

Figure 1a) shows a basic circuit to operate the ADS7806 with a  $\pm 10V$  input range and parallel output. Taking  $R/\overline{C}$  (pin 22) LOW for 40ns (12 $\mu$ s max) will initiate a conversion.  $\overline{BUSY}$  (pin 24) will go LOW and stay LOW until the conversion is completed and the output register is updated. If  $BYTE$  (pin 21) is LOW, the 8 most significant bits will be valid when  $\overline{BUSY}$  rises; if  $BYTE$  is HIGH, the 4 least significant bits will be valid when  $\overline{BUSY}$  rises. Data will be output in Binary Two's Complement format.  $\overline{BUSY}$  going HIGH can be used to latch the data. After the first byte has been read,  $BYTE$  can be toggled allowing the remaining byte to be read. All convert commands will be ignored while  $\overline{BUSY}$  is LOW.

The ADS7806 will begin tracking the input signal at the end of the conversion. Allowing 25 $\mu$ s between convert commands assures accurate acquisition of a new signal.

The offset and gain are adjusted internally to allow external trimming with a single supply. The external resistors compensate for this adjustment and can be left out if the offset and gain will be corrected in software (refer to the **Calibration** section).

## SERIAL OUTPUT

Figure 1b) shows a basic circuit to operate the ADS7806 with a  $\pm 10V$  input range and serial output. Taking  $R/\overline{C}$  (pin 22) LOW for 40ns (12 $\mu$ s max) will initiate a conversion and

output valid data from the previous conversion on  $SDATA$  (pin 19) synchronized to 12 clock pulses output on  $DATACLK$  (pin 18).  $\overline{BUSY}$  (pin 24) will go LOW and stay LOW until the conversion is completed and the serial data has been transmitted. Data will be output in Binary Two's Complement format, MSB first, and will be valid on both the rising and falling edges of the data clock.  $\overline{BUSY}$  going HIGH can be used to latch the data. All convert commands will be ignored while  $\overline{BUSY}$  is LOW.

The ADS7806 will begin tracking the input signal at the end of the conversion. Allowing 25 $\mu$ s between convert commands assures accurate acquisition of a new signal.

The offset and gain are adjusted internally to allow external trimming with a single supply. The external resistors compensate for this adjustment and can be left out if the offset and gain will be corrected in software (refer to the **Calibration** section).

# STARTING A CONVERSION

The combination of  $\overline{CS}$  (pin 23) and  $R/\overline{C}$  (pin 22) LOW for a minimum of 40ns immediately puts the sample/hold of the ADS7806 in the hold state and starts conversion 'n'.  $\overline{BUSY}$  (pin 24) will go LOW and stay LOW until conversion 'n' is completed and the internal output register has been updated. All new convert commands during  $\overline{BUSY}$  LOW will be ignored.  $\overline{CS}$  and/or  $R/\overline{C}$  must go HIGH before  $\overline{BUSY}$  goes HIGH or a new conversion will be initiated without sufficient time to acquire a new signal.

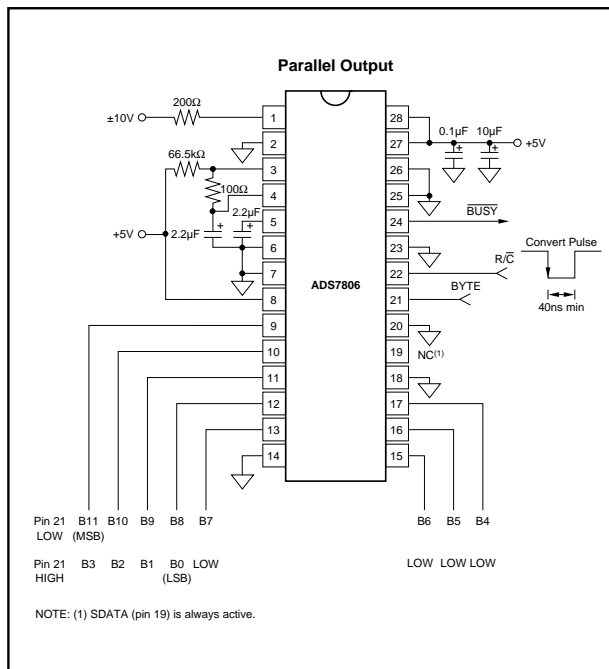

FIGURE 1a. Basic  $\pm 10V$  Operation, both Parallel and Serial Output.

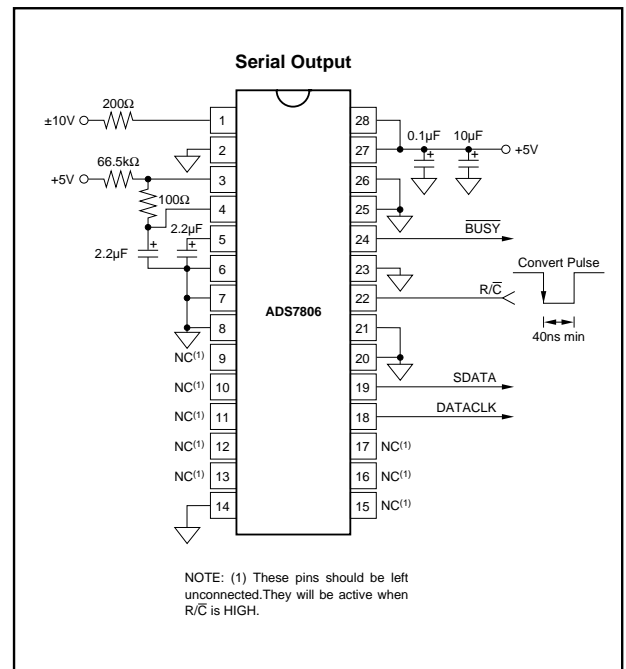

FIGURE 1b. Basic  $\pm 10V$  Operation with Serial Output.

The ADS7806 will begin tracking the input signal at the end of the conversion. Allowing 25µs between convert commands assures accurate acquisition of a new signal. Refer to Tables III and IV for a summary of  $\overline{CS}$ ,  $R/\overline{C}$ , and  $\overline{BUSY}$  states and Figures 2 through 6 for timing diagrams.

$\overline{CS}$	$R/\overline{C}$	$\overline{BUSY}$	OPERATION
1	X	X	None. Databus is in Hi-Z state.
↓	0	1	Initiates conversion "n". Databus remains in Hi-Z state.
0	↓	1	Initiates conversion "n". Databus enters Hi-Z state.
0	1	↑	Conversion "n" completed. Valid data from conversion "n" on the databus.
↓	1	1	Enables databus with valid data from conversion "n".
↓	1	0	Enables databus with valid data from conversion "n-1" <sup>(1)</sup> . Conversion n in progress.
0	↑	0	Enables databus with valid data from conversion "n-1" <sup>(1)</sup> . Conversion "n" in progress.
0	0	↑	New conversion initiated without acquisition of a new signal. Data will be invalid. $\overline{CS}$ and/or $R/\overline{C}$ must be HIGH when $\overline{BUSY}$ goes HIGH.
X	X	0	New convert commands ignored. Conversion "n" in progress.

NOTE: (1) See Figures 2 and 3 for constraints on data valid from conversion "n-1".

Table III. Control Functions When Using Parallel Output (DATACLK tied LOW, EXT/INT tied HIGH).

$\overline{CS}$  and  $R/\overline{C}$  are internally OR'd and level triggered. There is not a requirement which input goes LOW first when initiating a conversion. If, however, it is critical that  $\overline{CS}$  or  $R/\overline{C}$  initiates conversion 'n', be sure the less critical input is LOW at least 10ns prior to the initiating input. If EXT/INT (pin 8) is LOW when initiating conversion 'n', serial data from conversion 'n-1' will be output on SDATA (pin 19) following the start of conversion 'n'. See **Internal Data Clock** in the **Reading Data** section.

To reduce the number of control pins,  $\overline{CS}$  can be tied LOW using  $R/\overline{C}$  to control the read and convert modes. This will have no effect when using the internal data clock in the serial output mode. However, the parallel output and the serial output (only when using an external data clock) will be affected whenever  $R/\overline{C}$  goes HIGH. Refer to the **Reading Data** section.

## READING DATA

The ADS7806 outputs serial or parallel data in Straight Binary or Binary Two's Complement data output format. If SB/BTC (pin 7) is HIGH, the output will be in SB format, and if LOW, the output will be in BTC format. Refer to Table V for ideal output codes.

The parallel output can be read without affecting the internal output registers; however, reading the data through the serial

$\overline{CS}$	$R/\overline{C}$	$\overline{BUSY}$	EXT/INT	DATACLK	OPERATION
↓	0	1	0	Output	Initiates conversion "n". Valid data from conversion "n-1" clocked out on SDATA.
0	↓	1	0	Output	Initiates conversion "n". Valid data from conversion "n-1" clocked out on SDATA.
↓	0	1	1	Input	Initiates conversion "n". Internal clock still runs conversion process.
0	↓	1	1	Input	Initiates conversion "n". Internal clock still runs conversion process.
↓	1	1	1	Input	Conversion "n" completed. Valid data from conversion "n" clocked out on SDATA synchronized to external data clock.
↓	1	0	1	Input	Valid data from conversion "n-1" output on SDATA synchronized to external data clock. Conversion "n" in progress.
0	↑	0	1	Input	Valid data from conversion "n-1" output on SDATA synchronized to external data clock. Conversion "n" in progress.
0	0	↑	X	X	New conversion initiated without acquisition of a new signal. Data will be invalid. $\overline{CS}$ and/or $R/\overline{C}$ must be HIGH when $\overline{BUSY}$ goes HIGH.
X	X	0	X	X	New convert commands ignored. Conversion "n" in progress.

NOTE: (1) See Figures 4, 5, and 6 for constraints on data valid from conversion "n-1".

Table IV. Control Functions When Using Serial Output.

DESCRIPTION	ANALOG INPUT			DIGITAL OUTPUT			
				BINARY TWO'S COMPLEMENT (SB/BTC LOW)		STRAIGHT BINARY (SB/BTC HIGH)	
Full-Scale Range	±10	0V to 5V	0V to 4V	BINARY CODE	HEX CODE	BINARY CODE	HEX CODE
Least Significant Bit (LSB)	4.88mV	1.22mV	976µV	0111 1111 1111 1111	7FF	1111 1111 1111 1111	FFF
+Full Scale (FS – 1LSB)	9.99512V	4.99878V	3.999024V	0000 0000 0000 0000	000	1000 0000 0000 0000	800
Midscale	0V	2.5V	2V	1111 1111 1111 1111	FFF	0111 1111 1111 1111	7FF
One LSB Below Midscale	-4.88mV	2.49878V	1.999024V	1000 0000 0000 0000	800	0000 0000 0000 0000	000
-Full Scale	-10V	0V	0V				

Table V. Output Codes and Ideal Input Voltages.

port will shift the internal output registers one bit per data clock pulse. As a result, data can be read on the parallel port prior to reading the same data on the serial port, but data cannot be read through the serial port prior to reading the same data on the parallel port.

### PARALLEL OUTPUT

To use the parallel output, tie  $\overline{\text{EXT/INT}}$  (pin 8) HIGH and  $\text{DATACLK}$  (pin 18) LOW.  $\text{SDATA}$  (pin 19) should be left unconnected. The parallel output will be active when  $\overline{\text{R/C}}$  (pin 22) is HIGH and  $\overline{\text{CS}}$  (pin 23) is LOW. Any other combination of  $\overline{\text{CS}}$  and  $\overline{\text{R/C}}$  will tri-state the parallel output. Valid conversion data can be read in two 8-bit bytes on D7-D0 (pins 9-13 and 15-17). When  $\text{BYTE}$  (pin 21) is LOW, the 8 most significant bits will be valid with the MSB on D7. When  $\text{BYTE}$  is HIGH, the 4 least significant bits will be valid with the LSB on D4.  $\text{BYTE}$  can be toggled to read both bytes within one conversion cycle.

Upon initial power up, the parallel output will contain indeterminate data.

### PARALLEL OUTPUT (After a Conversion)

After conversion 'n' is completed and the output registers have been updated,  $\overline{\text{BUSY}}$  (pin 24) will go HIGH. Valid data from conversion 'n' will be available on D7-D0 (pins 9-13 and 15-17).  $\overline{\text{BUSY}}$  going high can be used to latch the data. Refer to Table VI and Figures 2 and 3 for timing constraints.

### PARALLEL OUTPUT (During a Conversion)

After conversion 'n' has been initiated, valid data from conversion 'n-1' can be read and will be valid up to 12 $\mu\text{s}$  after the start of conversion 'n'. Do not attempt to read data beyond 12 $\mu\text{s}$  after the start of conversion 'n' until  $\overline{\text{BUSY}}$  (pin 24) goes HIGH; this may result in reading invalid data. Refer to Table VI and Figures 2 and 3 for timing constraints.

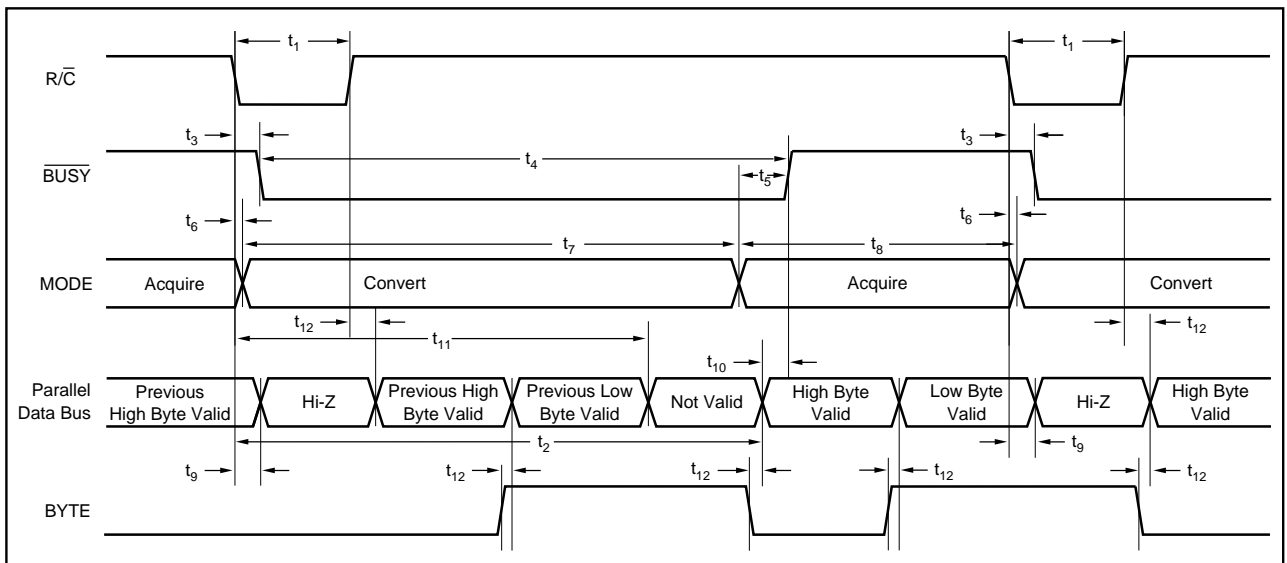

FIGURE 2. Conversion Timing with Parallel Output ( $\overline{\text{CS}}$  and  $\text{DATACLK}$  tied LOW,  $\overline{\text{EXT/INT}}$  tied HIGH).

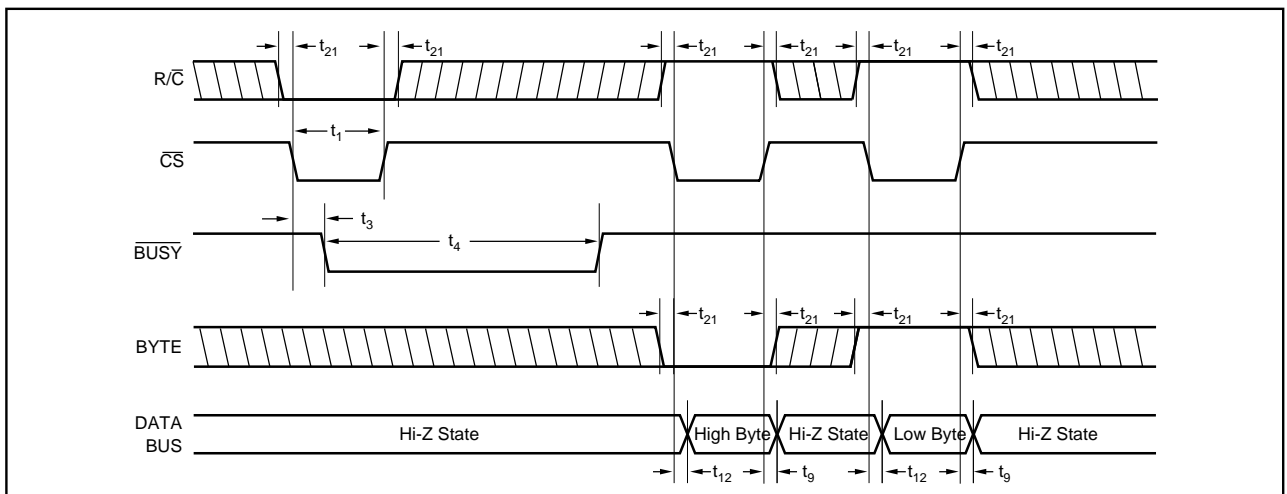

FIGURE 3. Using  $\overline{\text{CS}}$  to Control Conversion and Read Timing with Parallel Outputs.

## SERIAL OUTPUT

Data can be clocked out with the internal data clock or an external data clock. When using serial output, be careful with the parallel outputs, D7-D0 (pins 9-13 and 15-17), as these pins will come out of Hi-Z state whenever  $\overline{CS}$  (pin 23) is LOW and  $R/\overline{C}$  (pin 22) is HIGH. The serial output can not be tri-stated and is always active.

SYMBOL	DESCRIPTION	MIN	TYP	MAX	UNITS
$t_1$	Convert Pulse Width	0.04		12	$\mu$ s
$t_2$	Data Valid Delay after $R/\overline{C}$ LOW		14.7	20	$\mu$ s
$t_3$	$\overline{BUSY}$ Delay from Start of Conversion			85	ns
$t_4$	$\overline{BUSY}$ LOW		14.7	20	$\mu$ s
$t_5$	$\overline{BUSY}$ Delay after End of Conversion		90		ns
$t_6$	Aperture Delay		40		ns
$t_7$	Conversion Time		14.7		$\mu$ s
$t_8$	Acquisition Time			5	$\mu$ s
$t_9$	Bus Relinquish Time	10		83	ns
$t_{10}$	$\overline{BUSY}$ Delay after Data Valid	20	60		ns
$t_{11}$	Previous Data Valid after Start of Conversion	12	14.7		$\mu$ s
$t_{12}$	Bus Access Time and BYTE Delay			83	ns
$t_{13}$	Start of Conversion to DATACLK Delay		1.4		$\mu$ s
$t_{14}$	DATACLK Period		1.1		$\mu$ s
$t_{15}$	Data Valid to DATACLK HIGH Delay	20	75		ns
$t_{16}$	Data Valid after DATACLK LOW Delay	400	600		ns
$t_{17}$	External DATACLK Period	100			ns
$t_{18}$	External DATACLK LOW	40			ns
$t_{19}$	External DATACLK HIGH	50			ns
$t_{20}$	$\overline{CS}$ and $R/\overline{C}$ to External DATACLK Setup Time	25			ns
$t_{21}$	$R/\overline{C}$ to $\overline{CS}$ Setup Time	10			ns
$t_{22}$	Valid Data after DATACLK HIGH	25			ns
$t_7 + t_8$	Throughput Time			25	$\mu$ s

TABLE VI. Conversion and Data Timing.  $T_A = -40^\circ\text{C}$  to  $+85^\circ\text{C}$ .

## INTERNAL DATA CLOCK (During A Conversion)

To use the internal data clock, tie  $\text{EXT}/\overline{\text{INT}}$  (pin 8) LOW. The combination of  $R/\overline{C}$  (pin 22) and  $\overline{CS}$  (pin 23) LOW will initiate conversion 'n' and activate the internal data clock (typically 900kHz clock rate). The ADS7806 will output 12 bits of valid data, MSB first, from conversion 'n-1' on SDATA (pin 19), synchronized to 12 clock pulses output on DATACLK (pin 18). The data will be valid on both the rising and falling edges of the internal data clock. The rising edge of  $\overline{BUSY}$  (pin 24) can be used to latch the data. After the 12th clock pulse, DATACLK will remain LOW until the next conversion is initiated, while SDATA will go to whatever logic level was input on TAG (pin 20) during the first clock pulse. Refer to Table VI and Figure 4.

## EXTERNAL DATA CLOCK

To use an external data clock, tie  $\text{EXT}/\overline{\text{INT}}$  (pin 8) HIGH. The external data clock is not a conversion clock; it can only be used as a data clock. To enable the output mode of the ADS7806,  $\overline{CS}$  (pin 23) must be LOW and  $R/\overline{C}$  (pin 22) must be HIGH. DATACLK must be HIGH for 20% to 70% of the total data clock period; the clock rate can be between DC and 10MHz. Serial data from conversion 'n' can be output on SDATA (pin 19) after conversion 'n' is completed or during conversion 'n + 1'.

An obvious way to simplify control of the converter is to tie  $\overline{CS}$  LOW and use  $R/\overline{C}$  to initiate conversions. While this is perfectly acceptable, there is a possible problem when using an external data clock. At an indeterminate point from 12 $\mu$ s after the start of conversion 'n' until  $\overline{BUSY}$  rises, the internal logic will shift the results of conversion 'n' into the output register. If  $\overline{CS}$  is LOW,  $R/\overline{C}$  is HIGH, and the external clock is HIGH at this point, data will be lost. So, with  $\overline{CS}$  LOW, either  $R/\overline{C}$  and/or DATACLK must be LOW during this period to avoid losing valid data.

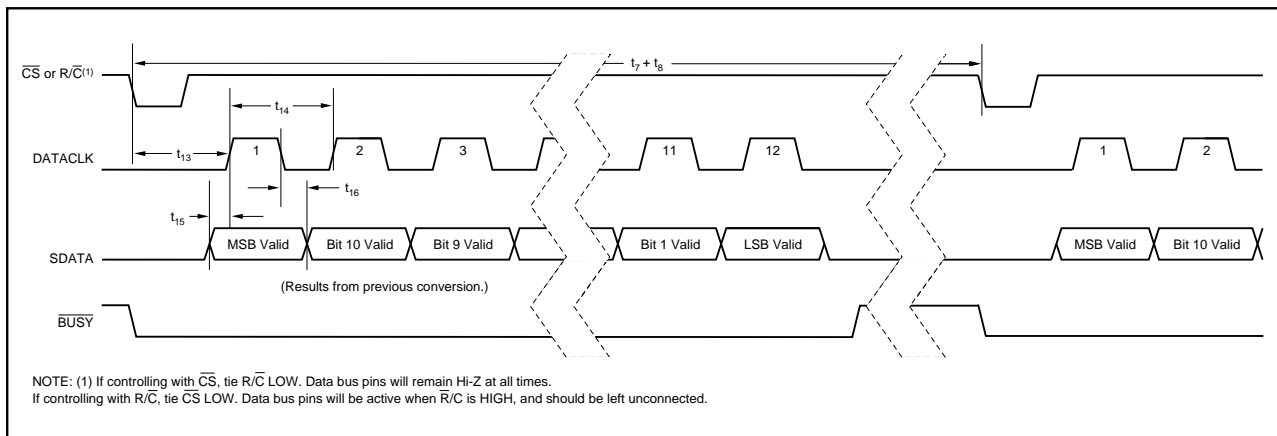

FIGURE 4. Serial Data Timing Using Internal Data Clock (TAG tied LOW).

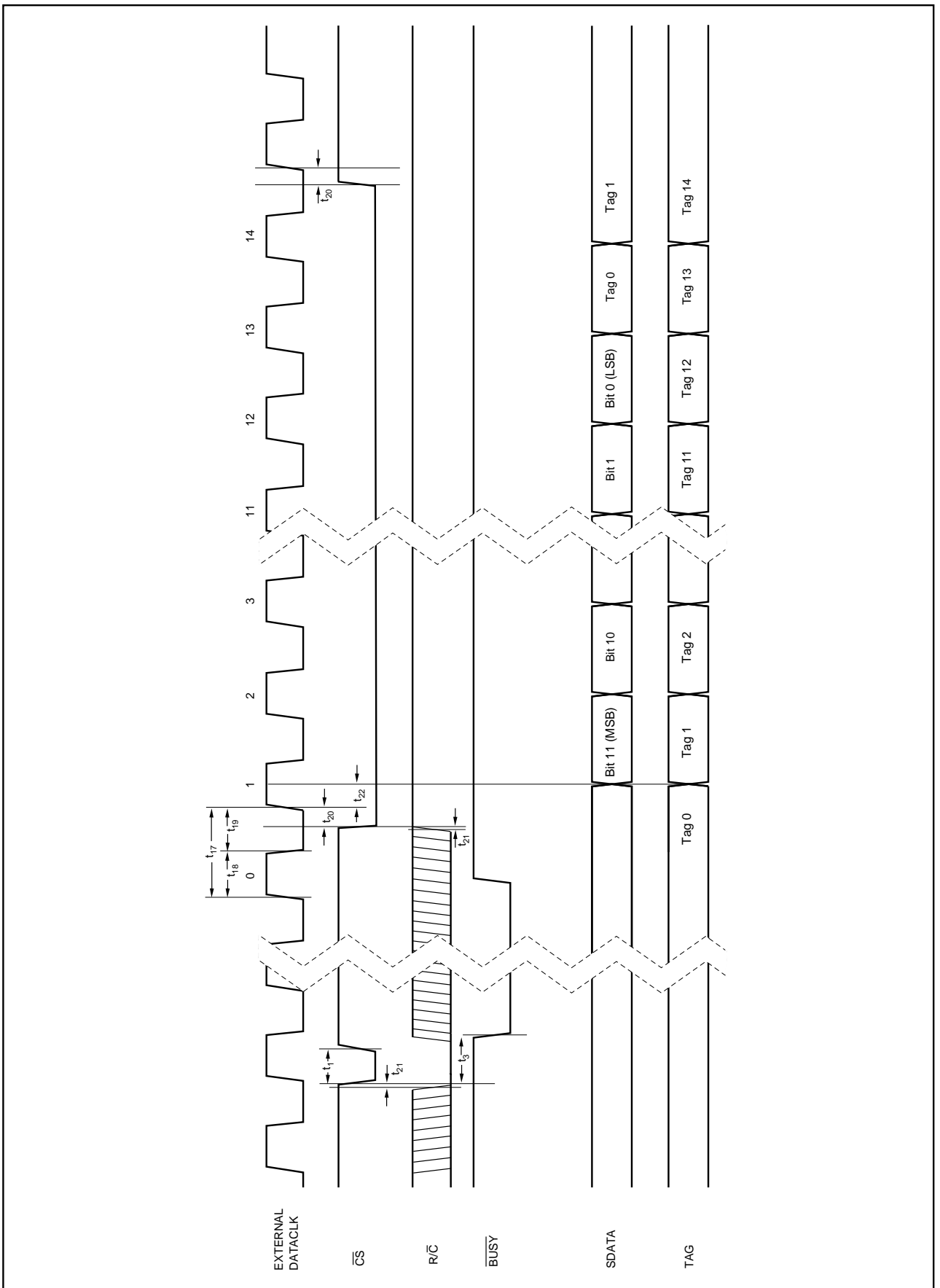

FIGURE 5. Conversion and Read Timing with External Clock (EXT/INT Tied HIGH) Read after Conversion.

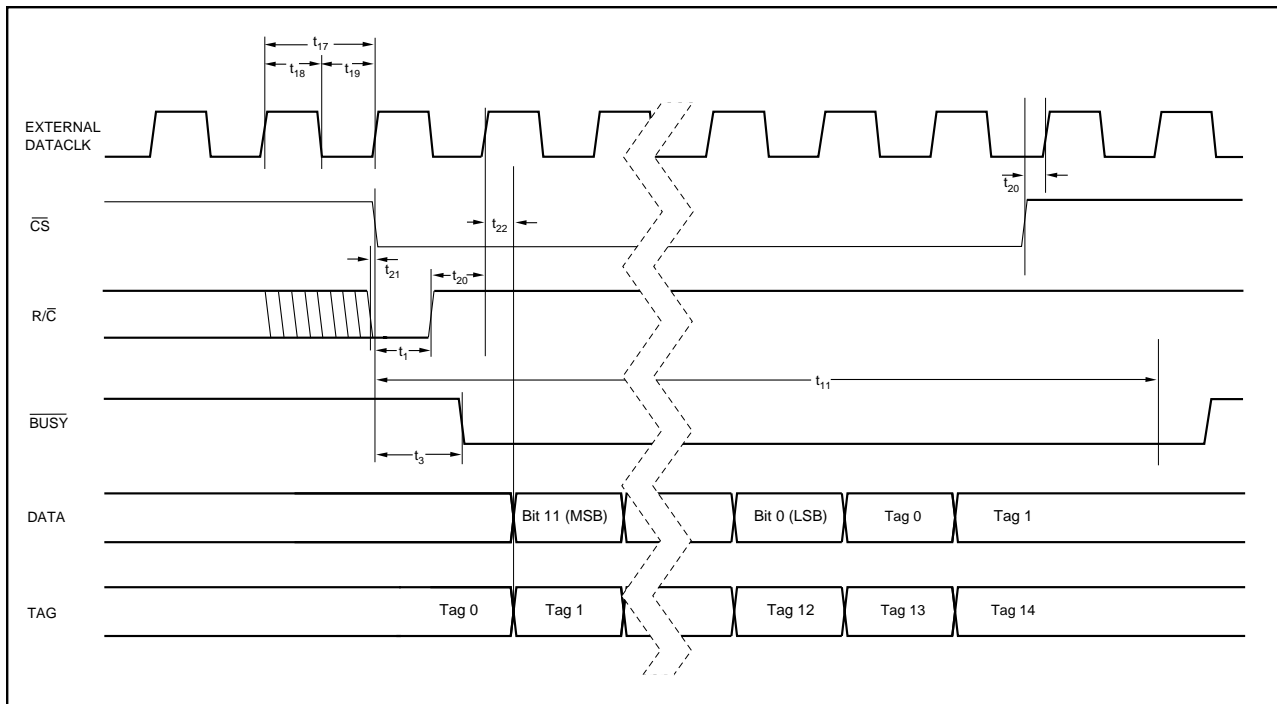

FIGURE 6. Conversion and Read Timing with External Clock ( $\overline{\text{EXT/INT}}$  tied HIGH) Read During a Conversion.

### EXTERNAL DATA CLOCK (After a Conversion)

After conversion 'n' is completed and the output registers have been updated,  $\overline{\text{BUSY}}$  (pin 24) will go HIGH. With  $\overline{\text{CS}}$  LOW and  $\overline{\text{R/C}}$  HIGH, valid data from conversion 'n' will be output on  $\overline{\text{SDATA}}$  (pin 19) synchronized to the external data clock input on  $\overline{\text{DATACLK}}$  (pin 18). The MSB will be valid on the first falling edge and the second rising edge of the external data clock. The LSB will be valid on the 12th falling edge and 13th rising edge of the data clock.  $\overline{\text{TAG}}$  (pin 20) will input a bit of data for every external clock pulse. The first bit input on  $\overline{\text{TAG}}$  will be valid on  $\overline{\text{SDATA}}$  on the 13th falling edge and the 14th rising edge of  $\overline{\text{DATACLK}}$ ; the second input bit will be valid on the 14th falling edge and the 15th rising edge, etc. With a continuous data clock,  $\overline{\text{TAG}}$  data will be output on  $\overline{\text{SDATA}}$  until the internal output registers are updated with the results from the next conversion. Refer to Table VI and Figure 5.

### EXTERNAL DATA CLOCK (During a Conversion)

After conversion 'n' has been initiated, valid data from conversion 'n-1' can be read and will be valid up to 12 $\mu\text{s}$  after the start of conversion 'n'. Do not attempt to clock out data from 12 $\mu\text{s}$  after the start of conversion 'n' until  $\overline{\text{BUSY}}$  (pin 24) rises; this will result in data loss. NOTE: For the best possible performance when using an external data clock, data should not be clocked out during a conversion. The switching noise of the asynchronous data clock can cause digital feedthrough degrading the converter's performance. Refer to Table VI and Figure 6.

### TAG FEATURE

$\overline{\text{TAG}}$  (Pin 20) inputs serial data synchronized to the external or internal data clock.

When using an external data clock, the serial bit stream input on  $\overline{\text{TAG}}$  will follow the LSB output on  $\overline{\text{SDATA}}$  until the internal output register is updated with new conversion results. See Table VI and Figures 5 and 6.

The logic level input on  $\overline{\text{TAG}}$  for the first rising edge of the internal data clock will be valid on  $\overline{\text{SDATA}}$  after all 12 bits of valid data have been output.

### INPUT RANGES

The ADS7806 offers three input ranges: standard  $\pm 10\text{V}$  and 0-5V, and a 0-4V range for complete, single supply systems. Figures 7a and 7b show the necessary circuit connections for implementing each input range and optional offset and gain adjust circuitry. Offset and full scale error<sup>(1)</sup> specifications are tested and guaranteed with the fixed resistors shown in Figure 7b. Adjustments for offset and gain are described in the **Calibration** section of this data sheet.

The offset and gain are adjusted internally to allow external trimming with a single supply. The external resistors compensate for this adjustment and can be left out if the offset and gain will be corrected in software (refer to the **Calibration** section).

The input impedance, summarized in Table II, results from the combination of the internal resistor network shown on the front page of the product data sheet and the external resistors

NOTE: (1) Full scale error includes offset and gain errors measured at both +FS and -FS.

used for each input range (see Figure 8). The input resistor divider network provides inherent overvoltage protection guaranteed to at least  $\pm 25V$ .

Analog inputs above or below the expected range will yield either positive full scale or negative full scale digital outputs respectively. There will be no wrapping or folding over for analog inputs outside the nominal range.

## CALIBRATION

### HARDWARE CALIBRATION

To calibrate the offset and gain of the ADS7806 in hardware, install the resistors shown in Figure 7a. Table VII lists the hardware trim ranges relative to the input for each input range.

### SOFTWARE CALIBRATION

To calibrate the offset and gain in software, no external resistors are required. However, to get the data sheet speci-

INPUT RANGE	OFFSET ADJUST RANGE (mV)	GAIN ADJUST RANGE (mV)
$\pm 10V$	$\pm 15$	$\pm 60$
0 to 5V	$\pm 4$	$\pm 30$
0 to 4V	$\pm 3$	$\pm 30$

TABLE VII. Offset and Gain Adjust Ranges for Hardware Calibration (see Figure 7a).

fications for offset and gain, the resistors shown in Figure 7b are necessary. See the **No Calibration** section for more details on the external resistors. Refer to Table VIII for the range of offset and gain errors with and without the external resistors.

### NO CALIBRATION

See Figure 7b for circuit connections. Note that the actual voltage dropped across the external resistors is at least two orders of magnitude lower than the voltage dropped across the internal resistor divider network. This should be consid-

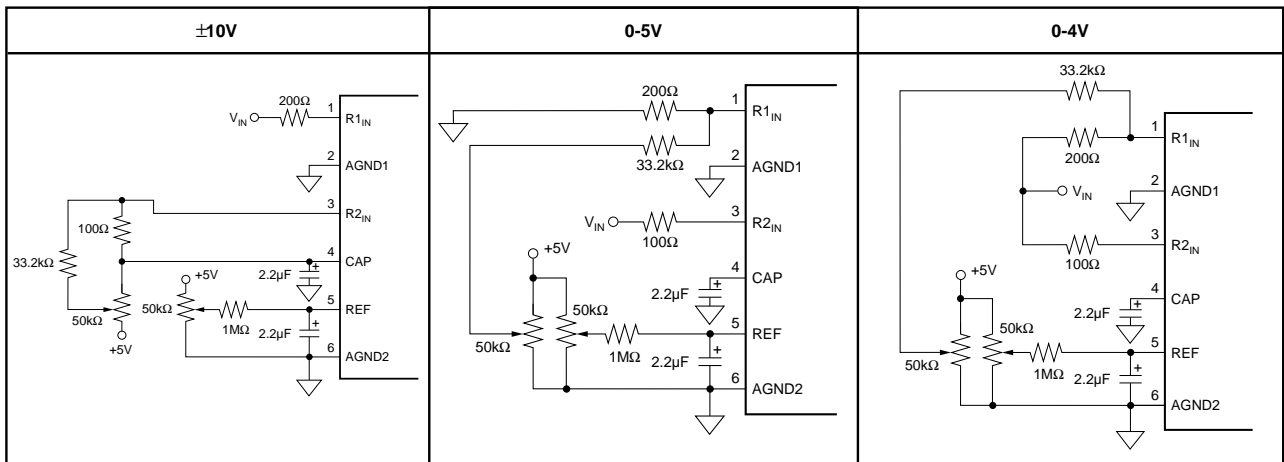

FIGURE 7a. Circuit Diagrams (With Hardware Trim).

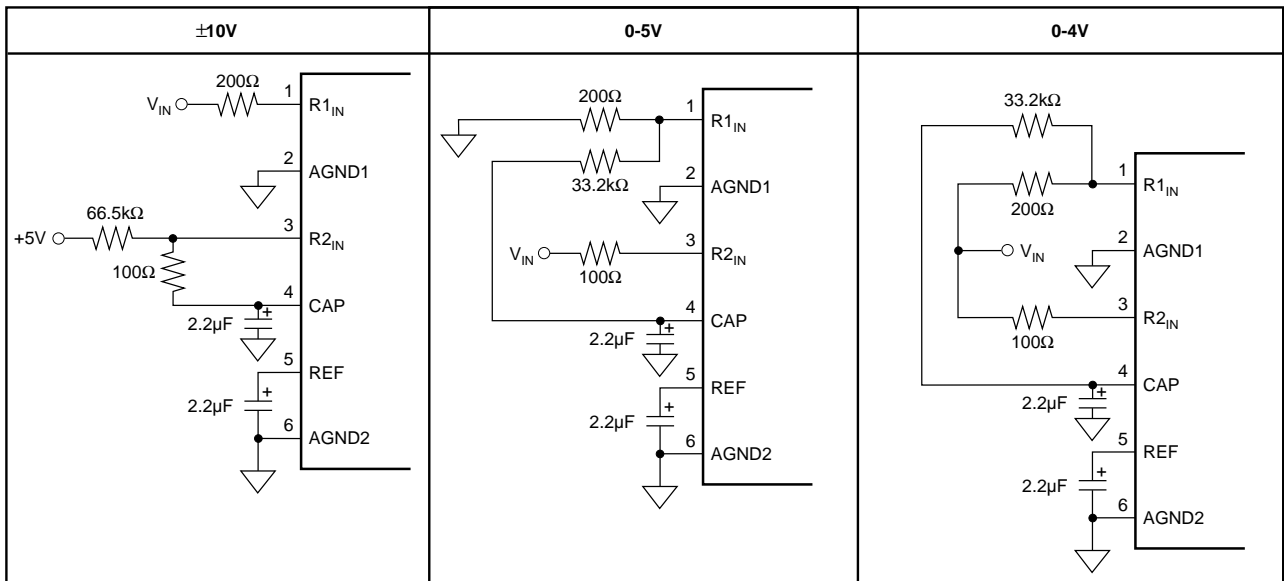

FIGURE 7b. Circuit Diagrams (Without Hardware Trim).

ered when choosing the accuracy and drift specifications of the external resistors. In most applications, 1% metal-film resistors will be sufficient.

The external resistors shown in Figure 7b may not be necessary in some applications. These resistors provide compensation for an internal adjustment of the offset and gain which allows calibration with a single supply. Not using the external resistors will result in offset and gain errors in addition to those listed in the electrical specifications section. Offset refers to the equivalent voltage of the digital output when converting with the input grounded. A positive gain error occurs when the equivalent output voltage of the digital output is larger than the analog input. Refer to Table VIII for nominal ranges of gain and offset errors with and without the external resistors. Refer to Figure 8 for typical shifts in the transfer functions which occur when the external resistors are removed.

To further analyze the effects of removing any combination of the external resistors, consider Figure 9. The combination of the external and the internal resistors form a voltage divider which reduces the input signal to a 0.3125V to 2.8125V input range at the CDAC. The internal resistors are laser trimmed to high relative accuracy to meet full specifications. The actual input impedance of the internal resistor network looking into pin 1 or pin 3 however, is only accurate to  $\pm 20\%$  due to process variations. This should be taken into account when determining the effects of removing the external resistors.

## REFERENCE

The ADS7806 can operate with its internal 2.5V reference or an external reference. By applying an external reference to

INPUT RANGE (V)	OFFSET ERROR			GAIN ERROR		
	W/ RESISTORS	W/OUT RESISTORS		W/ RESISTORS	W/OUT RESISTORS	
	RANGE (mV)	RANGE (mV)	TYP (mV)	RANGE (% FS)	RANGE (% FS)	TYP
$\pm 10$	$-10 \leq \text{BPZ} \leq 10$	$0 \leq \text{BPZ} \leq 35$	+15	$-0.4 \leq G \leq 0.4$ $0.15 \leq G^{(1)} \leq 0.15$	$-0.3 \leq G \leq 0.5$ $-0.1 \leq G^{(1)} \leq 0.2$	+0.05 +0.05
0 to 5	$-3 \leq \text{UPO} \leq 3$	$-12 \leq \text{UPO} \leq -3$	-7.5	$-0.4 \leq G \leq 0.4$ $0.15 \leq G^{(1)} \leq 0.15$	$-1.0 \leq G \leq 0.1$ $-0.55 \leq G^{(1)} \leq -0.05$	-0.2 -0.2
0 to 4	$-3 \leq \text{UPO} \leq 3$	$-10.5 \leq \text{UPO} \leq -1.5$	-6	$-0.4 \leq G \leq 0.4$ $-0.15 \leq G^{(1)} \leq 0.15$	$-1.0 \leq G \leq 0.1$ $-0.55 \leq G^{(1)} \leq -0.05$	-0.2 -0.2

Note: (1) High Grade.

TABLE VIII. Range of Offset and Gain Errors with and without External Resistors

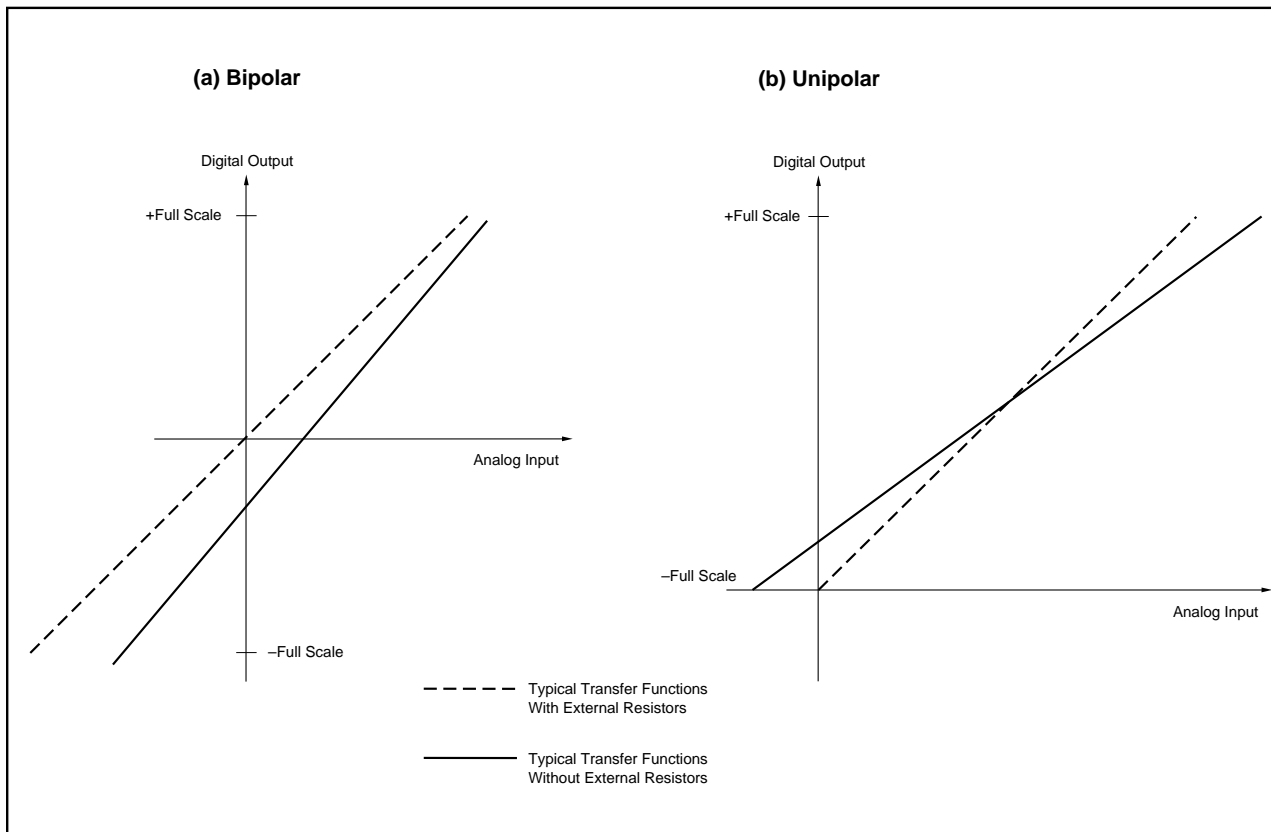

FIGURE 8. Typical Transfer Functions With and Without External Resistors.

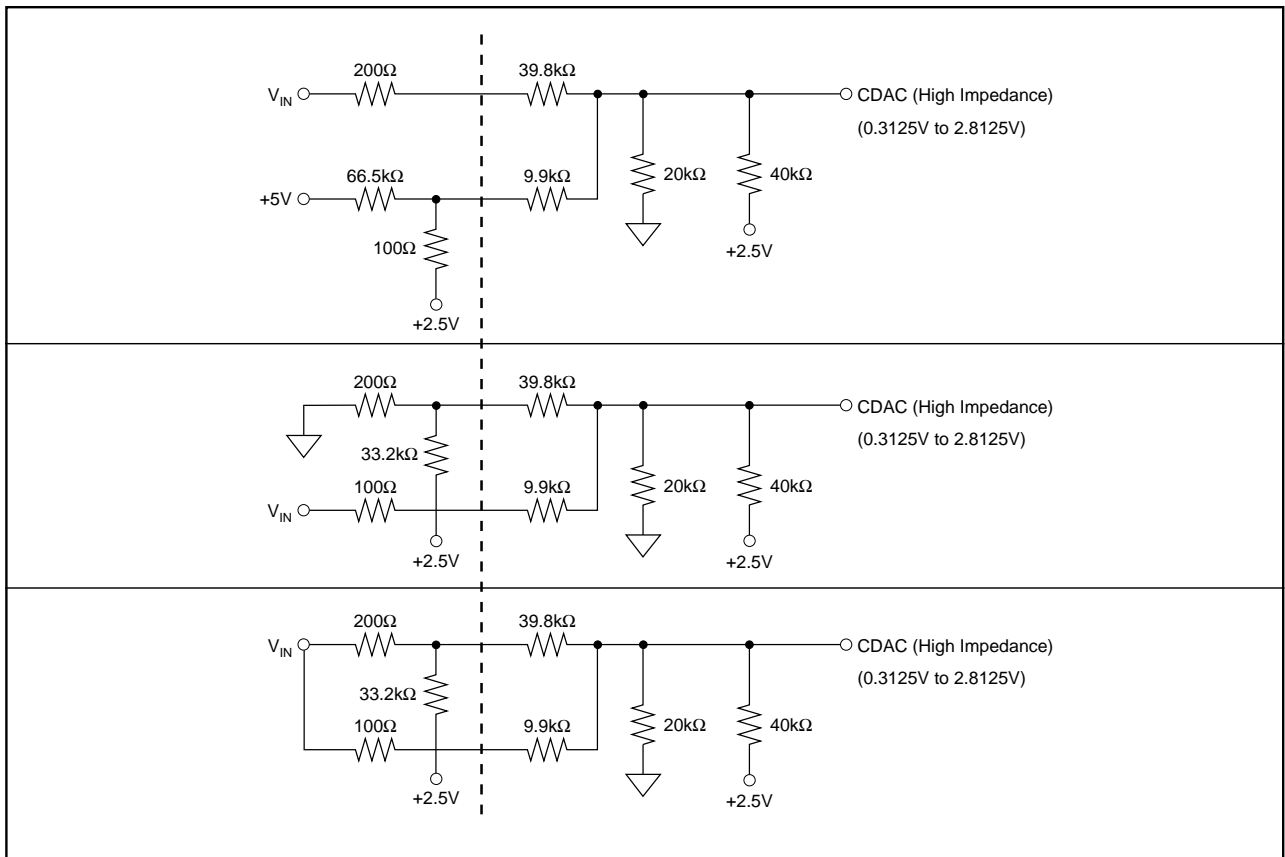

FIGURE 9. Circuit Diagrams Showing External and Internal Resistors.

pin 5, the internal reference can be bypassed; REFD (pin 26) tied HIGH will power-down the internal reference reducing the overall power consumption of the ADS7806 by approximately 5mW.

The internal reference has approximately an 8 ppm/°C drift (typical) and accounts for approximately 20% of the full scale error (FSE = ±0.5% for low grade, ±0.25% for high grade).

The ADS7806 also has an internal buffer for the reference voltage. See Figure 10 for characteristic impedances at the input and output of the buffer with all combinations of power down and reference down.

## REF

REF (pin 5) is an input for an external reference or the output for the internal 2.5V reference. A 2.2μF tantalum capacitor should be connected as close as possible to the REF pin from ground. This capacitor and the output resistance of REF create a low pass filter to bandlimit noise on the reference. Using a smaller value capacitor will introduce more noise to the reference, degrading the SNR and SINAD. The REF pin should not be used to drive external AC or DC loads. See Figure 10.

The range for the external reference is 2.3V to 2.7V and determines the actual LSB size. Increasing the reference voltage will increase the full scale range and the LSB size of the converter which can improve the SNR.

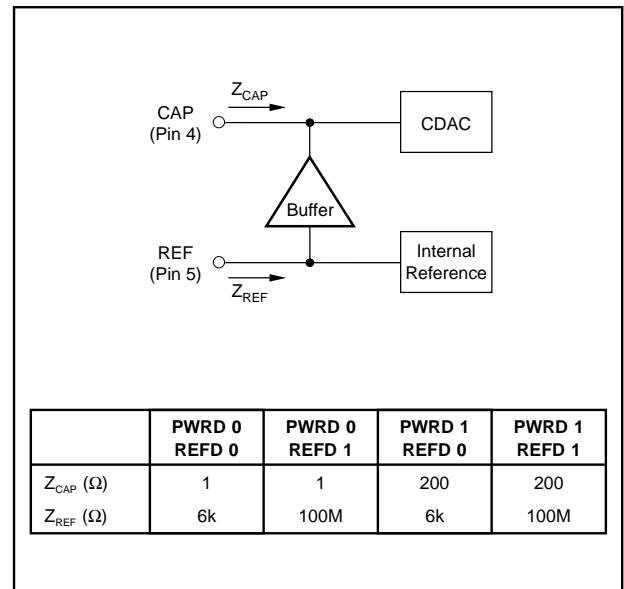

FIGURE 10. Characteristic Impedances of Internal Buffer.

## CAP

CAP (pin 4) is the output of the internal reference buffer. A 2.2μF tantalum capacitor should be placed as close as possible to the CAP pin from ground to provide optimum switching currents for the CDAC throughout the conversion cycle. This capacitor also provides compensation for the

output of the buffer. Using a capacitor any smaller than 1 $\mu$ F can cause the output buffer to oscillate and may not have sufficient charge for the CDAC. Capacitor values larger than 2.2 $\mu$ F will have little effect on improving performance. See Figures 10 and 11.

The output of the buffer is capable of driving up to 1mA of current to a DC load. Using an external buffer will allow the internal reference to be used for larger DC loads and AC loads. Do not attempt to directly drive an AC load with the output voltage on CAP. This will cause performance degradation of the converter.

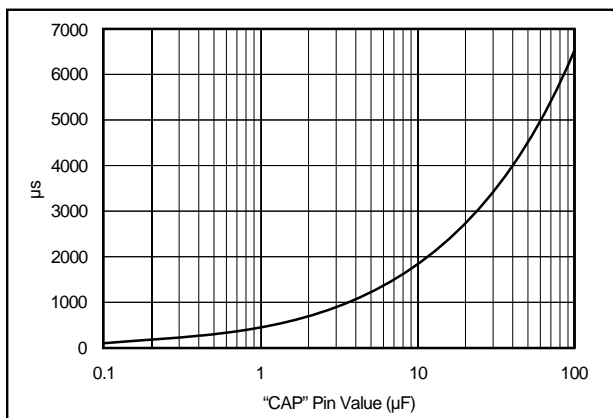

FIGURE 11. Power-Down to Power-Up Time vs Capacitor Value on CAP.

## REFERENCE AND POWER DOWN

The ADS7806 has analog power down and reference power down capabilities via PWRD (pin 25) and REFD (pin 26) respectively. PWRD and REFD HIGH will power down all analog circuitry maintaining data from the previous conversion in the internal registers, provided that the data has not already been shifted out through the serial port. Typical power consumption in this mode is 50 $\mu$ W. Power recovery is typically 1ms, using a 2.2 $\mu$ F capacitor connected to CAP. See Figure 11 for power-down to power-up recovery time relative to the capacitor value on CAP. With +5V applied to  $V_{DIG}$ , the digital circuitry of the ADS7806 remains active at all times, regardless of PWRD and REFD states.

### PWRD

PWRD HIGH will power down all of the analog circuitry except for the reference. Data from the previous conversion will be maintained in the internal registers and can still be read. With PWRD HIGH, a convert command yields meaningless data.

### REFD

REFD HIGH will power down the internal 2.5V reference. All other analog circuitry, including the reference buffer, will be active. REFD should be HIGH when using an external reference to minimize power consumption and the

loading effects on the external reference. See Figure 10 for the characteristic impedance of the reference buffer's input for both REFD HIGH and LOW. The internal reference consumes approximately 5mW.

## LAYOUT

### POWER

For optimum performance, tie the analog and digital power pins to the same +5V power supply and tie the analog and digital grounds together. As noted in the electrical specifications, the ADS7806 uses 90% of its power for the analog circuitry. The ADS7806 should be considered as an analog component.

The +5V power for the A/D should be separate from the +5V used for the system's digital logic. Connecting  $V_{DIG}$  (pin 28) directly to a digital supply can reduce converter performance due to switching noise from the digital logic. For best performance, the +5V supply can be produced from whatever analog supply is used for the rest of the analog signal conditioning. If +12V or +15V supplies are present, a simple +5V regulator can be used. Although it is not suggested, if the digital supply must be used to power the converter, be sure to properly filter the supply. Either using a filtered digital supply or a regulated analog supply, both  $V_{DIG}$  and  $V_{ANA}$  should be tied to the same +5V source.

### GROUNDING

Three ground pins are present on the ADS7806.  $D_{GND}$  is the digital supply ground.  $A_{GND2}$  is the analog supply ground.  $A_{GND1}$  is the ground to which all analog signals internal to the A/D are referenced.  $A_{GND1}$  is more susceptible to current induced voltage drops and must have the path of least resistance back to the power supply.

All the ground pins of the A/D should be tied to an analog ground plane, separated from the system's digital logic ground, to achieve optimum performance. Both analog and digital ground planes should be tied to the "system" ground as near to the power supplies as possible. This helps to prevent dynamic digital ground currents from modulating the analog ground through a common impedance to power ground.

### SIGNAL CONDITIONING

The FET switches used for the sample hold on many CMOS A/D converters release a significant amount of charge injection which can cause the driving op amp to oscillate. The amount of charge injection due to the sampling FET switch on the ADS7806 is approximately 5-10% of the amount on similar ADCs with the charge redistribution DAC (CDAC) architecture. There is also a resistive front end which attenuates any charge which is released. The end result is a minimal requirement for the drive capability on the signal conditioning preceding the A/D. Any op amp sufficient for the signal in an application will be sufficient to drive the ADS7806.

The resistive front end of the ADS7806 also provides a guaranteed  $\pm 25V$  overvoltage protection. In most cases, this eliminates the need for external over voltage protection circuitry.

### INTERMEDIATE LATCHES

The ADS7806 does have tri-state outputs for the parallel port, but intermediate latches should be used if the bus will be active during conversions. If the bus is not active during conversion, the tri-state outputs can be used to isolate the A/D from other peripherals on the same bus.

Intermediate latches are beneficial on any monolithic A/D converter. The ADS7806 has an internal LSB size of  $610\mu V$ . Transients from fast switching signals on the parallel port, even when the A/D is tri-stated, can be coupled through the substrate to the analog circuitry causing degradation of converter performance. The effects of this phenomenon will be more obvious when using the pin-compatible ADS7807 or any of the other 16-bit converters in the ADS Family. This is due to the smaller internal LSB size of  $38\mu V$ .

## APPLICATIONS INFORMATION

### QSPI INTERFACING

Figure 12 shows a simple interface between the ADS7806 and any QSPI equipped microcontroller. This interface assumes that the convert pulse does not originate from the microcontroller and that the ADS7806 is the only serial peripheral.

Before enabling the QSPI interface, the microcontroller must be configured to monitor the slave select line. When a transition from LOW to HIGH occurs on Slave Select (SS) from  $\overline{BUSY}$  (indicating the end of the current conversion), the port can be enabled. If this is not done, the microcontroller and the and the A/D may be “out-of-sync.”

Figure 13 shows another interface between the ADS7806 and a QSPI equipped microcontroller. The interface allows the microcontroller to give the convert pulses while also allowing multiple peripherals to be connected to the serial

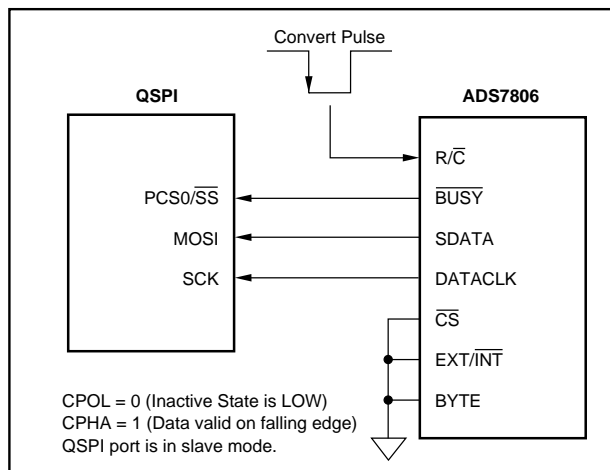

FIGURE 12. QSPI Interface to the ADS7806.

bus. This interface and the following discussion assume a master clock for the QSPI interface of 16.78MHz. Notice that the serial data input of the microcontroller is tied to the MSB (D7) of the ADS7806 instead of the serial output (SDATA). Using D7 instead of the serial port offers tri-state capability which allows other peripherals to be connected to the MISO pin. When communication is desired with those peripherals, PCS0 and PCS1 should be left HIGH; that will keep D7 tri-stated and prevent a conversion from taking place.

In this configuration, the QSPI interface is actually set to do two different serial transfers. The first, an eight bit transfer, causes PCS0 ( $R/\overline{C}$ ) and PCS1 ( $\overline{CS}$ ) to go LOW starting a conversion. The second, a twelve bit transfer, causes only PCS1 ( $\overline{CS}$ ) to go LOW. This is when the valid data will be transferred.

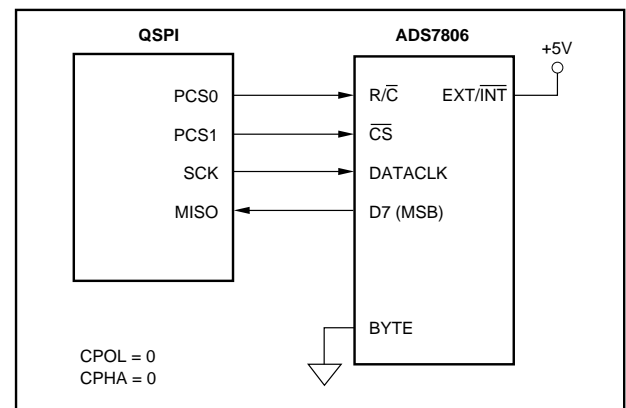

FIGURE 13. QSPI Interface to the ADS7806. Processor Initiates Conversions.

For both transfers, the DT register (delay after transfer) is used to cause a  $19\mu s$  delay. The interface is also set up to wrap to the beginning of the queue. In this manner, the QSPI is a state machine which generates the appropriate timing for the ADS7806. This timing is thus locked to the crystal based timing of the microcontroller and not interrupt driven. So, this interface is appropriate for both AC and DC measurements.

For the fastest conversion rate, the baud rate should be set to two (4.19MHz SCK), DT set to ten, the first serial transfer set to eight bits, the second set to twelve bits, and D $\overline{SCK}$  disabled (in the command control byte). This will allow for a 23kHz maximum conversion rate. For slower rates, DT should be increased. Do not slow SCK as this may increase the chance of affecting the conversion results or accidentally initiating a second conversion during the first eight bit transfer.

In addition, CPOL and CPHA should be set to zero (SCK normally LOW and data captured on the rising edge). The command control byte for the eight bit transfer should be set to 20H and for the twelve bit transfer to 61H.

## SPI INTERFACE

The SPI interface is generally only capable of 8-bit data transfers. For some microcontrollers with SPI interfaces, it might be possible to receive data in a similar manner as shown for the QSPI interface in Figure 12. The microcontroller will need to fetch the 8 most significant bits before the contents are overwritten by the least significant bits.

A modified version of the QSPI interface shown in Figure 13 might be possible. For most microcontrollers with SPI interface, the automatic generation of the start-of-conversion pulse will be impossible and will have to be done with software. This will limit the interface to 'DC' applications due to the insufficient jitter performance of the convert pulse itself.

## DSP56000 INTERFACING

The DSP56000 serial interface has an SPI compatibility mode with some enhancements. Figure 14 shows an interface between the ADS7806 and the DSP56000 which is very similar to the QSPI interface seen in Figure 12. As mentioned in the QSPI section, the DSP56000 must be programmed to enable the interface when a LOW to HIGH transition on SC1 is observed ( $\overline{\text{BUSY}}$  going HIGH at the end of conversion).

The DSP56000 can also provide the convert pulse by including a monostable multi-vibrator as seen in Figure 15. The receive and transmit sections of the interface are decoupled (asynchronous mode) and the transmit section is set to generate a word length frame sync every other transmit frame (frame rate divider set to two). The prescale modulus should be set to five.

The monostable multi-vibrator in this circuit will provide varying pulse widths for the convert pulse. The pulse width will be determined by the external R and C values used with the multi-vibrator. The 74HCT123N data sheet shows that

the pulse width is  $(0.7)RC$ . Choosing a pulse width as close to the minimum value specified in this data sheet will offer the best performance. See the **Starting A Conversion** section of this data sheet for details on the conversion pulse width.

The maximum conversion rate for a 20.48MHz DSP56000 is 35.6kHz. If a slower oscillator can be tolerated on the DSP56000, a conversion rate of 40kHz can be achieved by using a 19.2MHz clock and a prescale modulus of four.

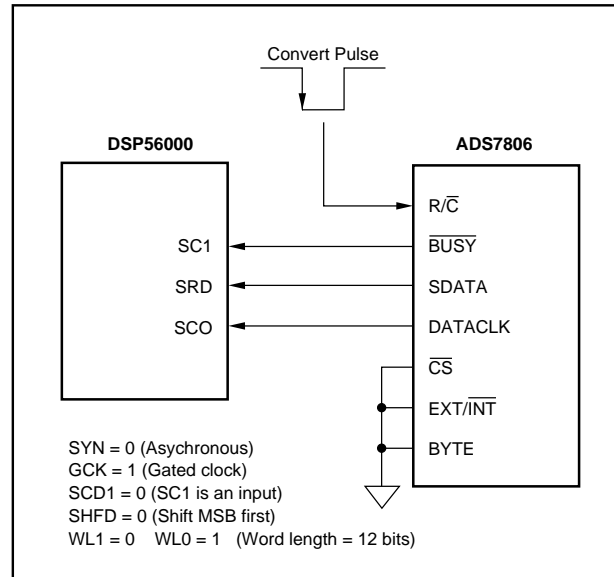

FIGURE 14. DSP56000 Interface to the ADS7806.

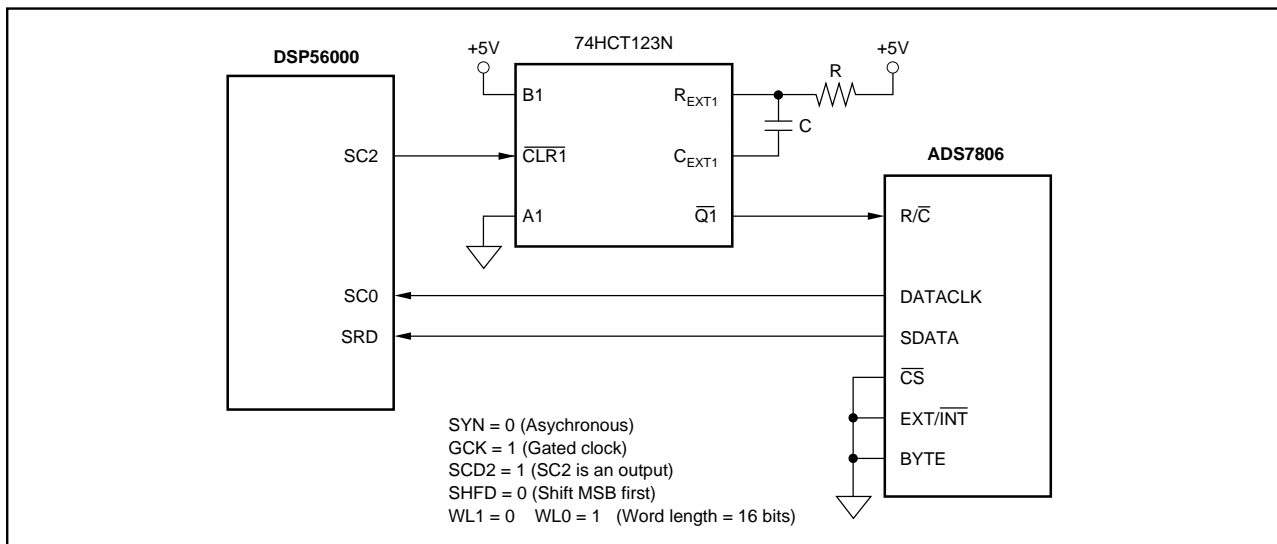

FIGURE 15. DSP56000 Interface to the ADS7806. Processor Initiates Conversions.

This datasheet has been downloaded from:

[www.DatasheetCatalog.com](http://www.DatasheetCatalog.com)

Datasheets for electronic components.



LittleDiode supplies new, hard to find or obsolete electronic components and semiconductors all over the world.

With over two million different components listed you are sure to find the part you need.

Feel free to visit us today at our online store:

[LittleDiode.com](http://LittleDiode.com)

Looking forward to providing you with the best possible service.