

## DS55451/2/3/4, DS75451/2/3/4 Series Dual Peripheral Drivers

### General Description

The DS7545X series of dual peripheral drivers is a family of versatile devices designed for use in systems that use TTL logic. Typical applications include high speed logic buffers, power drivers, relay drivers, lamp drivers, MOS drivers, bus drivers and memory drivers.

The DS55451/DS75451, DS55452/DS75452, DS55453/DS75453 and DS55454/DS75454 are dual peripheral AND, NAND, OR and NOR drivers, respectively, (positive logic) with the output of the logic gates internally connected to the bases of the NPN output transistors.

### Features

- 300 mA output current capability
- High voltage outputs
- No output latch-up at 20V
- High speed switching
- Choice of logic function
- TTL compatible diode-clamped inputs
- Standard supply voltages
- Replaces TI "A" and "B" series

### Connection Diagrams (Dual-In-Line and Metal Can Packages)

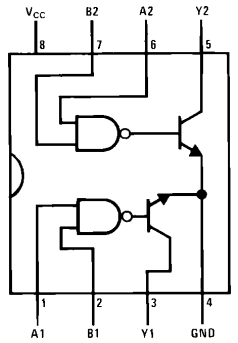

Top View

Order Number DS55451J-8,  
DS75451M or DS75451N

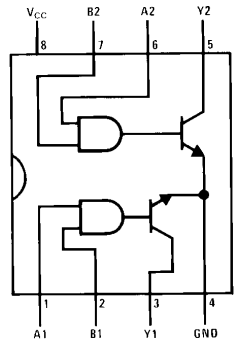

Top View

Order Number DS55452J-8,  
DS75452M or DS75452N

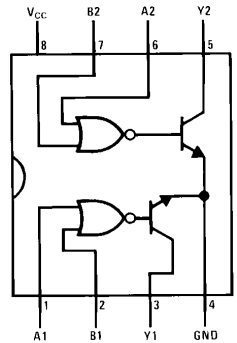

Top View

Order Number DS55453J-8,  
DS75453M or DS75453N

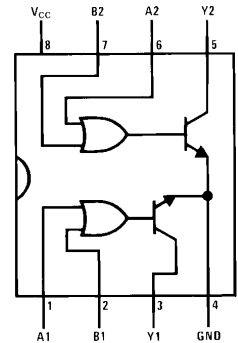

Top View

Order Number DS55454J-8,  
DS75454M or DS75454N

See NS Package Numbers J08A, M08A\* or N08E

\*See Note 5 and Appendix E regarding S.O. package power dissipation constraints.

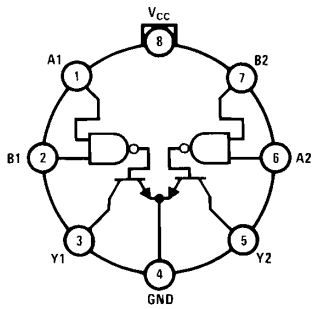

Top View

Order Number DS55451H

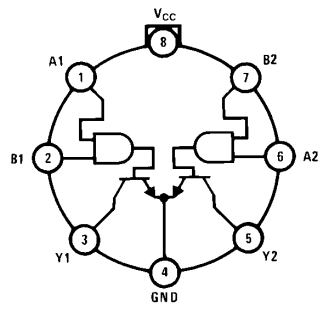

Top View

Order Number DS55452H  
(Pin 4 is in Electrical Contact with the Case)  
See NS Package Number H08C

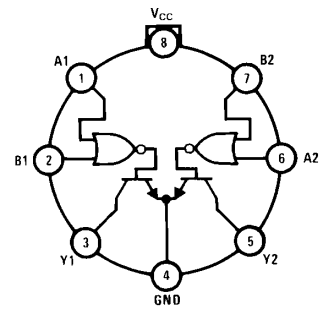

Top View

Order Number DS55453H

## Absolute Maximum Ratings (Note 1)

If Military/Aerospace specified devices are required, please contact the National Semiconductor Sales Office/Distributors for availability and specifications.

Supply Voltage, ( $V_{CC}$ ) (Note 2)	7.0V
Input Voltage	5.5V
Inter-Emitter Voltage (Note 3)	5.5V
Output Voltage (Note 4)	30V
DS55451/DS75451, DS55452/DS75452, DS55453/DS75453, DS55454/DS75454	
Output Current (Note 5)	300 mA
DS55451/DS75451, DS55452/DS75452, DS55453/DS75453, DS55454/DS75454	
DS75451/2/3/4 Maximum Power (Note 5)	
Dissipation <sup>†</sup> at 25°C	
Cavity Package	1090 mW
Molded DIP Package	957 mW
TO-5 Package	760 mW
SO Package	632 mW

Storage Temperature Range	-65°C to +150°C
Lead Temperature (Soldering, 4 sec.)	260°C

## Operating Conditions

	Min	Max	Units
Supply Voltage, ( $V_{CC}$ )			
DS5545X	4.5	5.5	V
DS7545X	4.75	5.25	V
Temperature, ( $T_A$ )			
DS5545X	-55	+125	°C
DS7545X	0	+70	°C

<sup>†</sup> Derate cavity package 7.3 mW/°C above 25°C; derate molded package 7.7 mW/°C above 25°C; derate TO-5 package 5.1 mW/°C above 25°C; derate SO package 7.56 mW/°C above 25°C.

## Electrical Characteristics

DS55451/DS75451, DS55452/DS75452, DS55453/DS75453, DS55454/DS75454 (Notes 6 and 7)

Symbol	Parameter	Conditions		Min	Typ	Max	Units	
$V_{IH}$	High-Level Input Voltage	(Figure 7)		2			V	
$V_{IL}$	Low-Level Input Voltage					0.8	V	
$V_I$	Input Clamp Voltage	$V_{CC} = \text{Min}, I_I = -12 \text{ mA}$				-1.5	V	
$V_{OL}$	Low-Level Output Voltage	$V_{CC} = \text{Min},$ (Figure 7)	$V_{IL} = 0.8 \text{ V}$	$I_{OL} = 100 \text{ mA}$	DS55451, DS55453	0.25	0.5	V
					DS75451, DS75453	0.25	0.4	V
				$I_{OL} = 300 \text{ mA}$	DS55451, DS55453	0.5	0.8	V
				DS75451, DS75453	0.5	0.7	V	
			$V_{IH} = 2 \text{ V}$	$I_{OL} = 100 \text{ mA}$	DS55452, DS55454	0.25	0.5	V
					DS75452, DS75454	0.25	0.4	V
$I_{OL} = 300 \text{ mA}$	DS55452, DS55454	0.5		0.8	V			
		DS75452, DS75454	0.5	0.7	V			
$I_{OH}$	High-Level Output Current	$V_{CC} = \text{Min},$ (Figure 7)	$V_{OH} = 30 \text{ V}$	$V_{IH} = 2 \text{ V}$	DS55451, DS55453		300	$\mu\text{A}$
					DS75451, DS75453		100	$\mu\text{A}$
				$V_{IL} = 0.8 \text{ V}$	DS55452, DS55454		300	$\mu\text{A}$
					DS75452, DS75454		100	$\mu\text{A}$
$I_I$	Input Current at Maximum Input Voltage	$V_{CC} = \text{Max}, V_I = 5.5 \text{ V},$ (Figure 9)				1	mA	
$I_{IH}$	High-Level Input Current	$V_{CC} = \text{Max}, V_I = 2.4 \text{ V},$ (Figure 9)				40	$\mu\text{A}$	
$I_{IL}$	Low-Level Input Current	$V_{CC} = \text{Max}, V_I = 0.4 \text{ V},$ (Figure 8)			-1	-1.6	mA	
$I_{CCH}$	Supply Current, Outputs High	$V_{CC} = \text{Max},$ (Figure 10)	$V_I = 5 \text{ V}$	DS55451/DS75451	7	11	mA	
			$V_I = 0 \text{ V}$	DS55452/DS75452	11	14	mA	
			$V_I = 5 \text{ V}$	DS55453/DS75453	8	11	mA	
			$V_I = 0 \text{ V}$	DS55454/DS75454	13	17	mA	
$I_{CCL}$	Supply Current, Outputs Low	$V_{CC} = \text{Max},$ (Figure 10)	$V_I = 0 \text{ V}$	DS55451/DS75451	52	65	mA	
			$V_I = 5 \text{ V}$	DS55452/DS75452	56	71	mA	
			$V_I = 0 \text{ V}$	DS55453/DS75453	54	68	mA	
			$V_I = 5 \text{ V}$	DS55454/DS75454	61	79	mA	

## Switching Characteristics

DS55451/DS75451, DS55452/DS75452, DS55453/DS75453, DS55454/DS75454 ( $V_{CC} = 5V$ ,  $T_A = 25^\circ C$ )

Symbol	Parameter	Conditions	Min	Typ	Max	Units
$t_{PLH}$	Propagation Delay Time, Low-to-High Level Output	$C_L = 15 \text{ pF}$ , $R_L = 50\Omega$ , $I_O \approx 200 \text{ mA}$ , (Figure 14)	DS55451/DS75451	18	25	ns
			DS55452/DS75452	26	35	ns
			DS55453/DS75453	18	25	ns
			DS55454/DS75454	27	35	ns
$t_{PHL}$	Propagation Delay Time, High-to-Low Level Output	$C_L = 15 \text{ pF}$ , $R_L = 50\Omega$ , $I_O \approx 200 \text{ mA}$ , (Figure 14)	DS55451/DS75451	18	25	ns
			DS55452/DS75452	24	35	ns
			DS55453/DS75453	16	25	ns
			DS55454/DS75454	24	35	ns
$t_{TLH}$	Transition Time, Low-to-High Level Output	$C_L = 15 \text{ pF}$ , $R_L = 50\Omega$ , $I_O \approx 200\text{mA}$ , (Figure 14)		5	8	ns
$t_{THL}$	Transition Time, High-to-Low Level Output	$C_L = 15 \text{ pF}$ , $R_L = 50\Omega$ , $I_O \approx 200 \text{ mA}$ , (Figure 14)		7	12	ns
$V_{OH}$	High-Level Output Voltage after Switching	$V_S = 20V$ , $I_O \approx 300 \text{ mA}$ , (Figure 15)	$V_S - 6.5$			mV

**Note 1:** "Absolute Maximum Ratings" are those values beyond which the safety of the device cannot be guaranteed. Except for "Operating Temperature Range" they are not meant to imply that the devices should be operated at these limits. The table of "Electrical Characteristics" provides conditions for actual device operation.

**Note 2:** Voltage values are with respect to network ground terminal unless otherwise specified.

**Note 3:** The voltage between two emitters of a multiple-emitter transistor.

**Note 4:** The maximum voltage which should be applied to any output when it is in the "OFF" state.

**Note 5:** Both halves of these dual circuits may conduct rated current simultaneously; however, power dissipation averaged over a short time interval must fall within the continuous dissipation rating.

**Note 6:** Unless otherwise specified min/max limits apply across the  $-55^\circ C$  to  $+125^\circ C$  temperature range for the DS55450 series and across the  $0^\circ C$  to  $+70^\circ C$  range for the DS7545X series. All typicals are given for  $V_{CC} = +5V$  and  $T_A = 25^\circ C$ .

**Note 7:** All currents into device pins shown as positive, out of device pins as negative, all voltages referenced to ground unless otherwise noted. All values shown as max or min on absolute value basis.

## Truth Tables (H = high level, L = low level)

**DS55451/DS75451**

A	B	Y
L	L	L (ON State)
L	H	L (ON State)
H	L	L (ON State)
H	H	H (OFF State)

**DS55453/DS75453**

A	B	Y
L	L	L (ON State)
L	H	H (OFF State)
H	L	H (OFF State)
H	H	H (OFF State)

**DS55452/DS75452**

A	B	Y
L	L	H (OFF State)
L	H	H (OFF State)
H	L	H (OFF State)
H	H	L (ON State)

**DS55454/DS75454**

A	B	Y
L	L	H (OFF State)
L	H	L (ON State)
H	L	L (ON State)
H	H	L (ON State)

## Schematic Diagrams

**DS55451/DS75451**

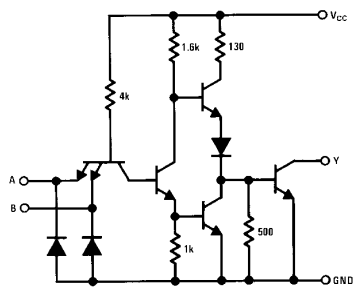

TL/F/5824-11

Resistor values shown are nominal.

**DS55453/DS75453**

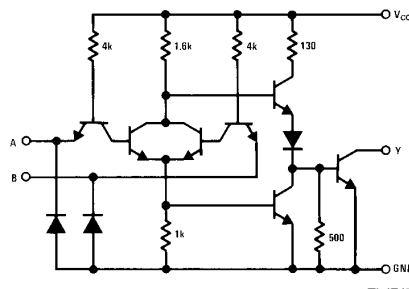

TL/F/5824-13

Resistor values shown are nominal.

**DS55452/DS75452**

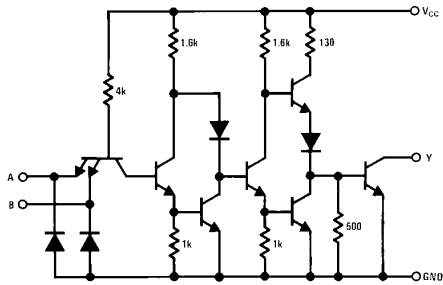

TL/F/5824-12

Resistor values shown are nominal.

**DS55454/DS75454**

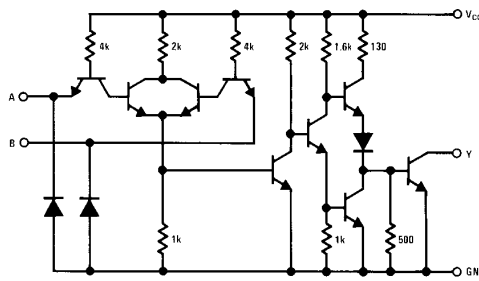

TL/F/5824-14

Resistor values shown are nominal.

## DC Test Circuits

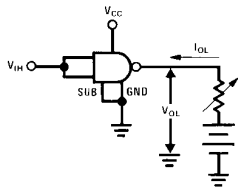

TL/F/5824-15

Both inputs are tested simultaneously.  
**FIGURE 1.  $V_{IH}$ ,  $V_{OL}$**

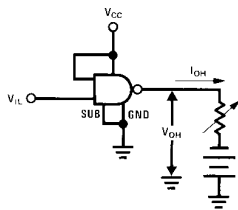

TL/F/5824-16

Each input is tested separately.  
**FIGURE 2.  $V_{IL}$ ,  $V_{OH}$**

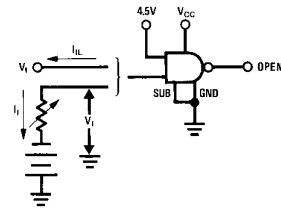

TL/F/5824-17

Each input is tested separately.  
**FIGURE 3.  $V_I$ ,  $I_{IL}$**

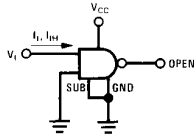

TL/F/5824-18

Each input is tested separately.  
**FIGURE 4.  $I_I$ ,  $I_{IH}$**

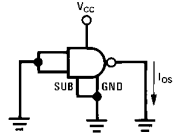

TL/F/5824-19

Each input is tested separately.  
**FIGURE 5.  $I_{OS}$**

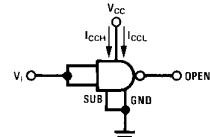

TL/F/5824-20

Both gates are tested simultaneously.  
**FIGURE 6.  $I_{CCH}$ ,  $I_{CCL}$**

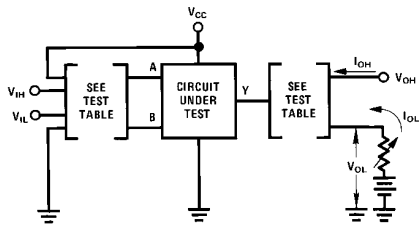

TL/F/5824-21

**FIGURE 7.  $V_{IH}$ ,  $V_{IL}$ ,  $I_{OH}$ ,  $V_{OL}$**

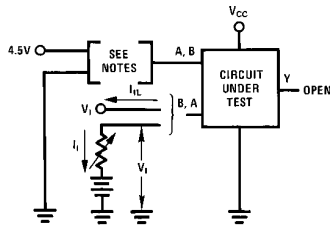

TL/F/5824-22

**FIGURE 8.  $V_I$ ,  $V_{IL}$**

**Note A:** Each input is tested separately.  
**Note B:** When testing DS55453/DS75453, DS55454/DS75454, input not under test is grounded. For all other circuits it is at 4.5V.

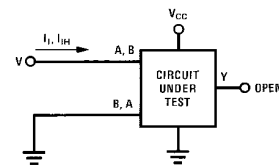

TL/F/5824-23

Each input is tested separately.

**FIGURE 9.  $I_I$ ,  $I_{IH}$**

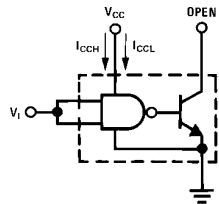

TL/F/5824-24

Both gates are tested simultaneously.  
**FIGURE 10.  $I_{CCH}$ ,  $I_{CCL}$  for AND, NAND Circuits**

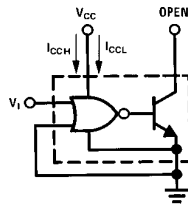

TL/F/5824-25

Both gates are tested simultaneously.  
**FIGURE 11.  $I_{CCH}$ ,  $I_{CCL}$  for OR, NOR Circuits**

Circuit	Input Under Test	Other Input	Output	
			Apply	Measure
DS55451	$V_{IH}$	$V_{IH}$	$V_{OH}$	$I_{OH}$
	$V_{IL}$	$V_{CC}$	$I_{OL}$	$V_{OL}$
DS55452	$V_{IH}$	$V_{IH}$	$I_{OL}$	$V_{OL}$
	$V_{IL}$	$V_{CC}$	$V_{OH}$	$I_{OH}$
DS55453	$V_{IH}$	Gnd	$V_{OH}$	$I_{OH}$
	$V_{IL}$	$V_{IL}$	$I_{OL}$	$V_{OH}$
DS55454	$V_{IH}$	Gnd	$I_{OL}$	$V_{OL}$
	$V_{IL}$	$V_{IL}$	$V_{OH}$	$I_{OH}$

## AC Test Circuits and Switching Time Waveforms

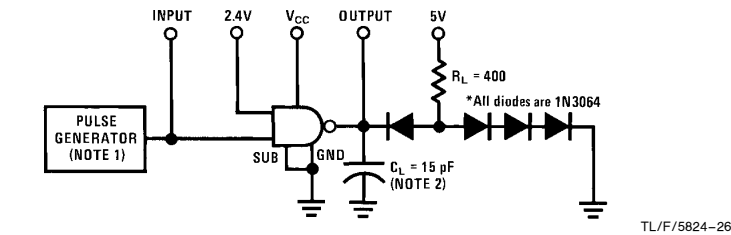

TL/F/5824-26

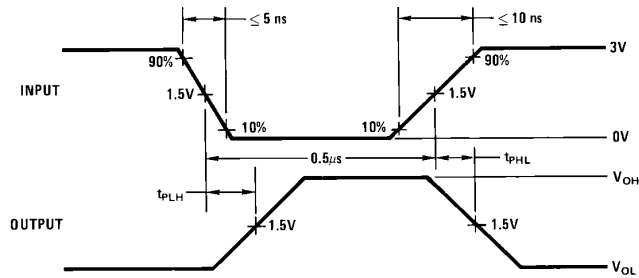

TL/F/5824-27

**Note 1:** The pulse generator has the following characteristics: PRR = 1 MHz,  $Z_{OUT} \approx 50\Omega$ .

**Note 2:**  $C_L$  includes probe and jig capacitance.

**FIGURE 12. Propagation Delay Times, Each Gate**

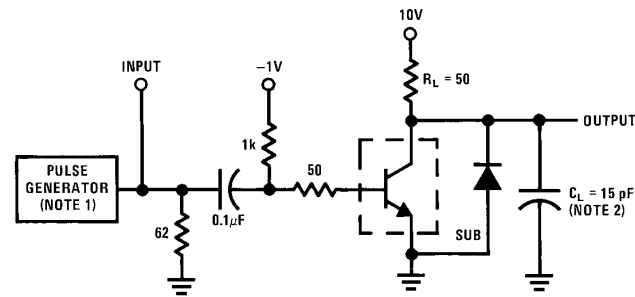

TL/F/5824-28

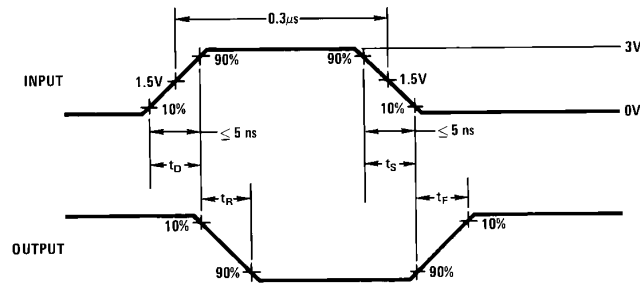

TL/F/5824-29

**Note 1:** The pulse generator has the following characteristics: duty cycle  $\le 1\%$ ,  $Z_{OUT} \approx 50\Omega$ .

**Note 2:**  $C_L$  includes probe and jig capacitance.

**FIGURE 13. Switching Times, Each Transistor**

## AC Test Circuits and Switching Time Waveforms (Continued)

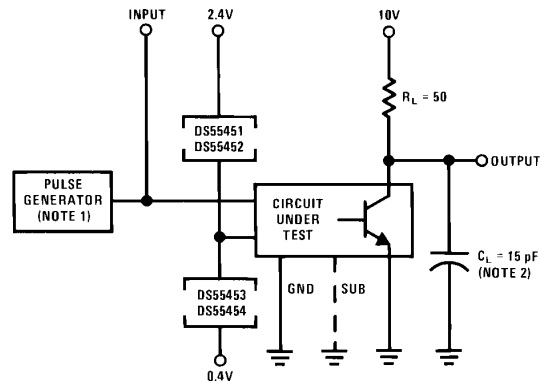

TL/F/5824-30

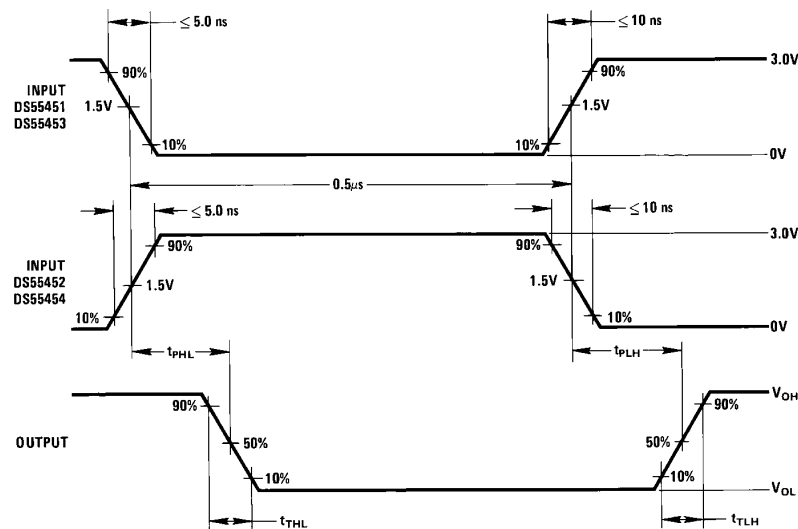

**Note 1:** The pulse generator has the following characteristics: PRR = 1.0 MHz,  $Z_{OUT} \approx 50 \Omega$ .

**Note 2:**  $C_L$  includes probe and jig capacitance.

TL/F/5824-31

**FIGURE 14. Switching Times of Complete Drivers**

## AC Test Circuits and Switching Time Waveforms (Continued)

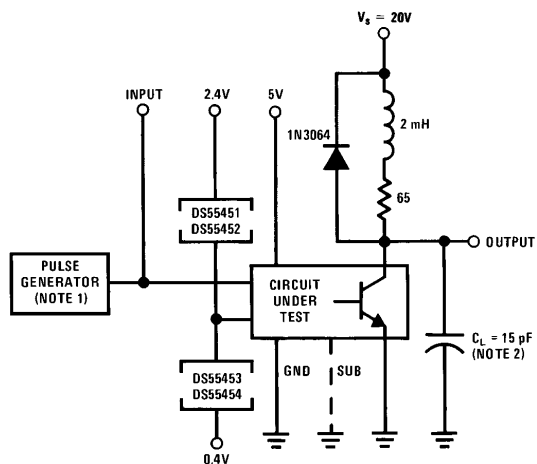

TL/F/5824-32

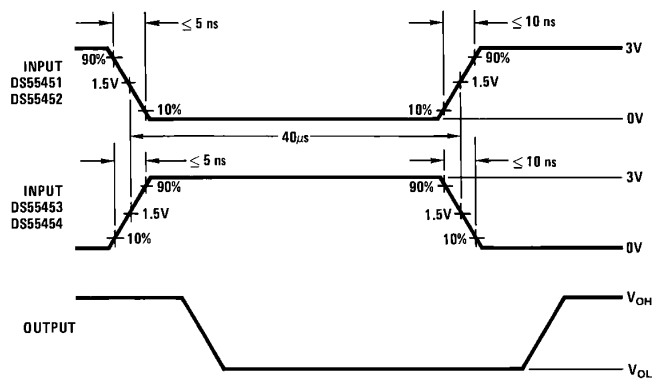

TL/F/5824-33

**Note 1:** The pulse generator has the following characteristics: PRR = 12.5 kHz,  $Z_{OUT} \approx 50\Omega$ .

**Note 2:**  $C_L$  includes probe and jig capacitance.

**FIGURE 15. Latch-Up Test of Complete Drivers**

## Typical Performance Characteristics

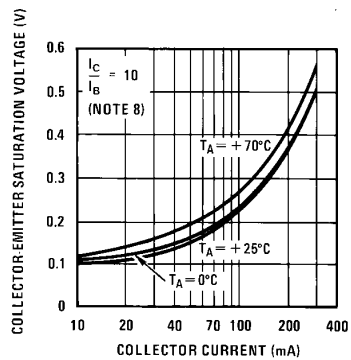

TL/F/5824-37

**FIGURE 16. Transistor Collector-Emitter Saturation Voltage vs Collector Current**

## Typical Applications

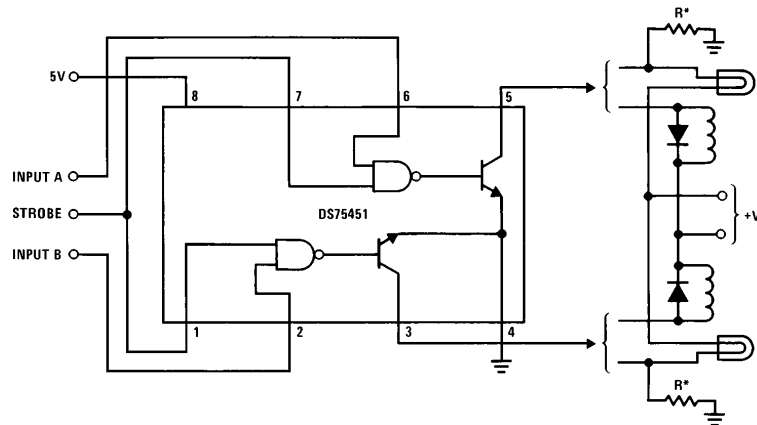

\*Optional keep-alive resistors maintain off-state lamp current at  $\approx 10\%$  to reduce surge current.

TL/F/5824-46

**FIGURE 17. Dual Lamp or Relay Driver**

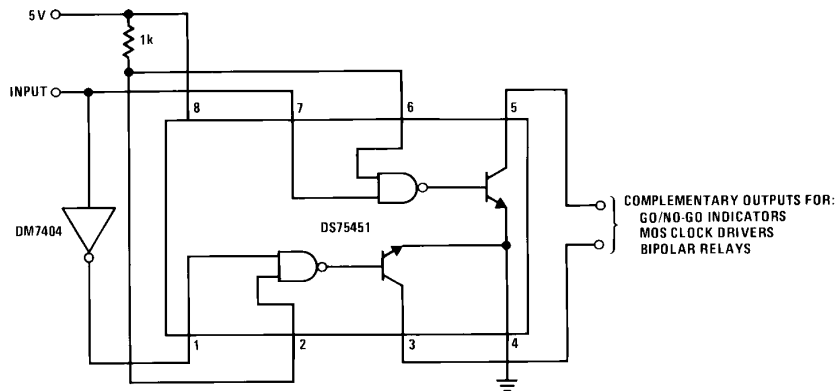

**FIGURE 18. Complementary Driver**

TL/F/5824-47

**Typical Applications** (Continued)

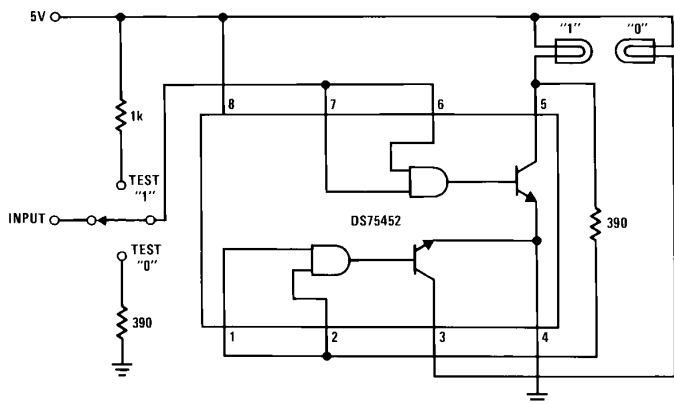

**FIGURE 19. TTL or DTL Positive Logic-Level Detector**

TL/F/5824-48

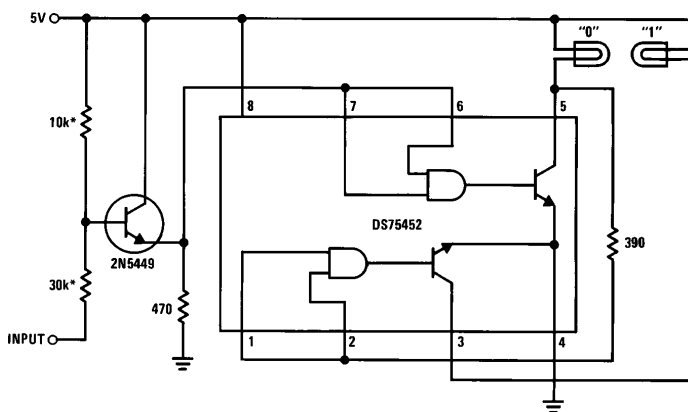

\*The two input resistors must be adjusted for the level of MOS input.

**FIGURE 20. MOS Negative Logic-Level Detector**

TL/F/5824-49

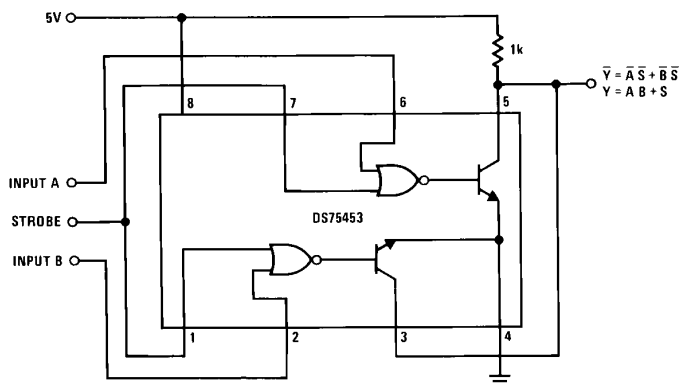

**FIGURE 21. Logic Signal Comparator**

TL/F/5824-50

## Typical Applications (Continued)

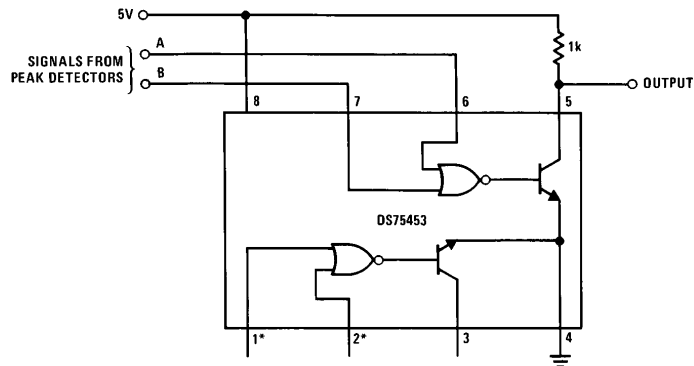

\*If inputs are unused, they should be connected to +5V through a 1k resistor.

TL/F/5824-51

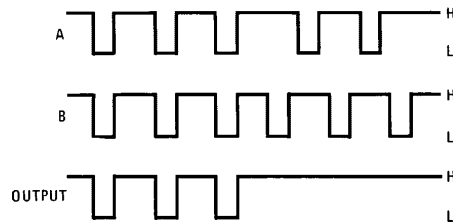

TL/F/5824-52

Low output occurs only when inputs are low simultaneously.

**FIGURE 22. In-Phase Detector**

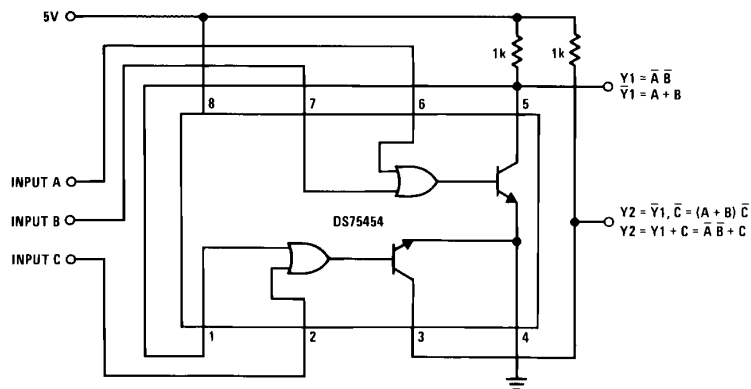

**FIGURE 23. Multifunction Logic-Signal Comparator**

TL/F/5824-53

Typical Applications (Continued)

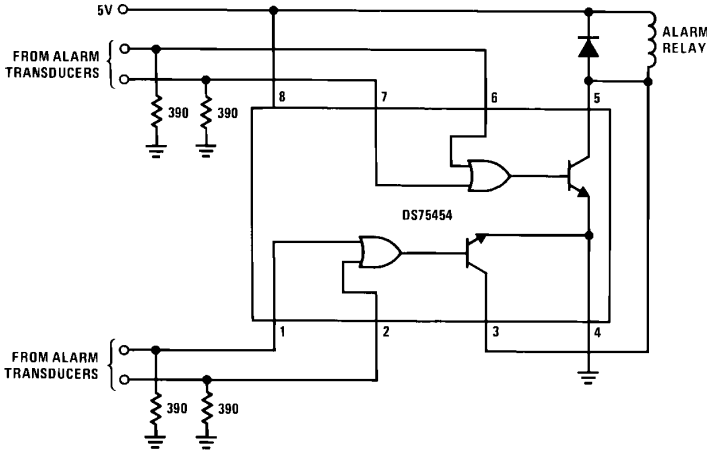
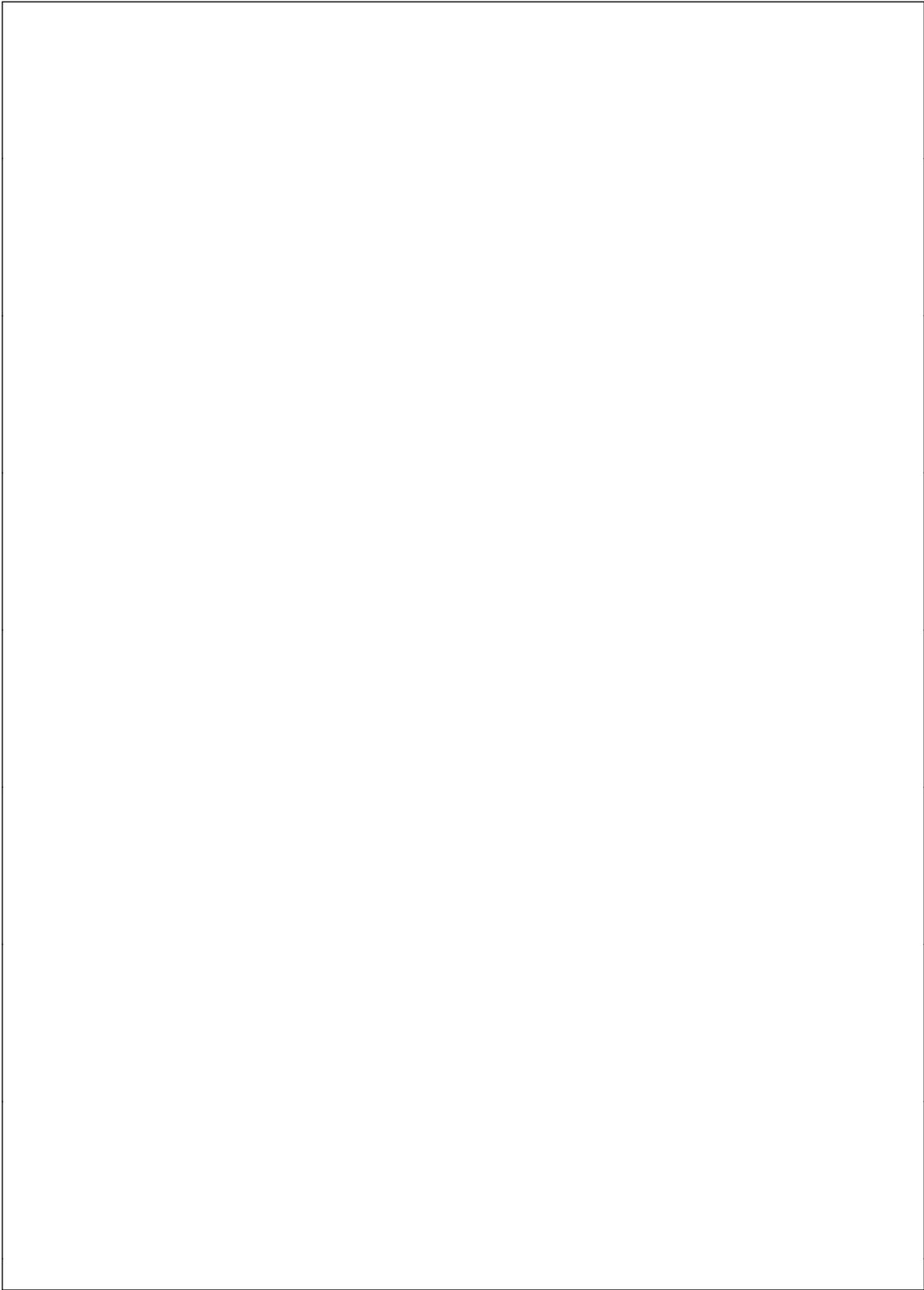

FIGURE 24. Alarm Detector

TL/F/5824-54







**LIFE SUPPORT POLICY**

NATIONAL'S PRODUCTS ARE NOT AUTHORIZED FOR USE AS CRITICAL COMPONENTS IN LIFE SUPPORT DEVICES OR SYSTEMS WITHOUT THE EXPRESS WRITTEN APPROVAL OF THE PRESIDENT OF NATIONAL SEMICONDUCTOR CORPORATION. As used herein:

1. Life support devices or systems are devices or systems which, (a) are intended for surgical implant into the body, or (b) support or sustain life, and whose failure to perform, when properly used in accordance with instructions for use provided in the labeling, can be reasonably expected to result in a significant injury to the user.
2. A critical component is any component of a life support device or system whose failure to perform can be reasonably expected to cause the failure of the life support device or system, or to affect its safety or effectiveness.



**National Semiconductor Corporation**  
1111 West Bardin Road  
Arlington, TX 76017  
Tel: 1(800) 272-9959  
Fax: 1(800) 737-7018

**National Semiconductor Europe**  
Fax: (+49) 0-180-530 85 86  
Email: [cnjwge@tevm2.nsc.com](mailto:cnjwge@tevm2.nsc.com)  
Deutsch Tel: (+49) 0-180-530 85 85  
English Tel: (+49) 0-180-532 78 32  
Français Tel: (+49) 0-180-532 93 58  
Italiano Tel: (+49) 0-180-534 16 80

**National Semiconductor Hong Kong Ltd.**  
19th Floor, Straight Block,  
Ocean Centre, 5 Canton Rd.  
Tsimshatsui, Kowloon  
Hong Kong  
Tel: (852) 2737-1600  
Fax: (852) 2736-9960

**National Semiconductor Japan Ltd.**  
Tel: 81-043-299-2309  
Fax: 81-043-299-2408

# National Semiconductor was acquired by Texas Instruments.

[http://www.ti.com/corp/docs/investor\\_relations/pr\\_09\\_23\\_2011\\_national\\_semiconductor.html](http://www.ti.com/corp/docs/investor_relations/pr_09_23_2011_national_semiconductor.html)

This file is the datasheet for the following electronic components:

DS75450 - <http://www.ti.com/product/ds75450?HQS=TI-null-null-dscatalog-df-pf-null-wwe>

DS75451 - <http://www.ti.com/product/ds75451?HQS=TI-null-null-dscatalog-df-pf-null-wwe>

DS55454 - <http://www.ti.com/product/ds55454?HQS=TI-null-null-dscatalog-df-pf-null-wwe>

DS55453 - <http://www.ti.com/product/ds55453?HQS=TI-null-null-dscatalog-df-pf-null-wwe>

DS75453 - <http://www.ti.com/product/ds75453?HQS=TI-null-null-dscatalog-df-pf-null-wwe>

DS55452 - <http://www.ti.com/product/ds55452?HQS=TI-null-null-dscatalog-df-pf-null-wwe>

DS75454 - <http://www.ti.com/product/ds75454?HQS=TI-null-null-dscatalog-df-pf-null-wwe>

DS55451 - <http://www.ti.com/product/ds55451?HQS=TI-null-null-dscatalog-df-pf-null-wwe>

DS75452 - <http://www.ti.com/product/ds75452?HQS=TI-null-null-dscatalog-df-pf-null-wwe>



LittleDiode supplies new, hard to find or obsolete electronic components and semiconductors all over the world.

With over two million different components listed you are sure to find the part you need.

Feel free to visit us today at our online store:

[LittleDiode.com](http://LittleDiode.com)

Looking forward to providing you with the best possible service.