

100304

Low Power Quint AND/NAND Gate

General Description

The 100304 is monolithic quint AND/NAND gate. The Function output is the wire-NOR of all five AND gate outputs. All inputs have 50 kΩ pull-down resistors.

Features

- Low Power Operation
- 2000V ESD protection
- Pin/function compatible with 100104
- Voltage compensated operating range = -4.2V to -5.7V
- Available to industrial grade temperature range (PLCC package only)

Ordering Code:

Order Number	Package Number	Package Description
100304PC	N24E	24-Lead Plastic Dual-In-Line Package (PDIP), JEDEC MS-010, 0.400 Wide
100304QC	V28A	28-Lead Plastic Lead Chip Carrier (PLCC), JEDEC MO-047, 0.450 Square
100304QI	V28A	28-Lead Plastic Lead Chip Carrier (PLCC), JEDEC MO-047, 0.450 Square Industrial Temperature Range (-40°C to +85°C)

Devices also available in Tape and Reel. Specify by appending the suffix letter "X" to the ordering code.

Logic Symbol

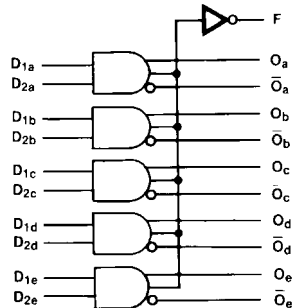

Connection Diagrams

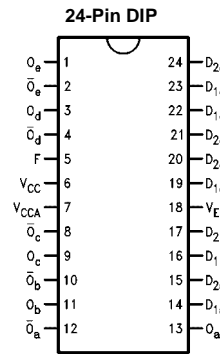

Pin Descriptions

Pin Names	Description
D _{na} -D _{ne}	Data Inputs
F	Function Output
O _a -O _e	Data Outputs
\bar{O}_a - \bar{O}_e	Complementary Data Outputs

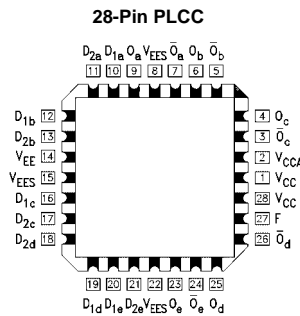

Logic Equation

$$F = (\bar{D}_{1a} \cdot \bar{D}_{2a}) + (\bar{D}_{1b} \cdot \bar{D}_{2b}) + (\bar{D}_{1c} \cdot \bar{D}_{2c}) + (\bar{D}_{1d} \cdot \bar{D}_{2d}) + (\bar{D}_{1e} \cdot \bar{D}_{2e})$$

Absolute Maximum Ratings (Note 1)

Storage Temperature (T_{STG})	-65°C to +150°C
Maximum Junction Temperature (T_J)	+150°C
V_{EE} Pin Potential to Ground Pin	-7.0V to +0.5V
Input Voltage (DC)	V_{EE} to +0.5V
Output Current (DC Output HIGH)	-50 mA
ESD (Note 2)	$\geq 2000V$

Recommended Operating Conditions

Case Temperature (T_C)	Commercial	0°C to +85°C
	Industrial	-40°C to +85°C
Supply Voltage (V_{EE})		-5.7V to -4.2V

Note 1: The "Absolute Maximum Ratings" are those values beyond which the safety of the device cannot be guaranteed. The device should not be operated at these limits. The parametric values defined in the Electrical Characteristics tables are not guaranteed at the absolute maximum rating. The "Recommended Operating Conditions" table will define the conditions for actual device operation.

Note 2: ESD testing conforms to MIL-STD-883, Method 3015.

Commercial Version**DC Electrical Characteristics** (Note 3)

$V_{EE} = -4.2V$ to $-5.7V$, $V_{CC} = V_{CCA} = GND$, $T_C = 0^\circ C$ to $+85^\circ C$

Symbol	Parameter	Min	Typ	Max	Units	Conditions
V_{OH}	Output HIGH Voltage	-1025	-955	-870	mV	$V_{IN} = V_{IH}(\text{Max})$ or $V_{IL}(\text{Min})$
V_{OL}	Output LOW Voltage	-1830	-1705	-1620	mV	
V_{OHC}	Output HIGH Voltage	-1035			mV	$V_{IN} = V_{IH}(\text{Min})$ or $V_{IL}(\text{Max})$
V_{OLC}	Output LOW Voltage			-1610	mV	
V_{IH}	Input HIGH Voltage	-1165		-870	mV	Guaranteed HIGH Signal for All Inputs
V_{IL}	Input LOW Voltage	-1830		-1475	mV	Guaranteed LOW Signal for All Inputs
I_{IL}	Input LOW Current	0.50			μA	$V_{IN} = V_{IL}(\text{Min})$
I_{IH}	Input High Current $D_{2a}-D_{2e}$ $D_{1a}-D_{1e}$			250 350	μA	$V_{IN} = V_{IH}(\text{Max})$
I_{EE}	Power Supply Current	-69	-43	-30	mA	Inputs open

Note 3: The specified limits represent the "worst case" value for the parameter. Since these values normally occur at the temperature extremes, additional noise immunity and guardbanding can be achieved by decreasing the allowable system operating ranges. Conditions for testing shown in the tables are chosen to guarantee operation under "worst case" conditions.

DIP AC Electrical Characteristics

$V_{EE} = -4.2V$ to $-5.7V$, $V_{CC} = V_{CCA} = GND$

Symbol	Parameter	$T_C = 0^\circ C$		$T_C = +25^\circ C$		$T_C = +85^\circ C$		Units	Conditions
		Min	Max	Min	Max	Min	Max		
t_{PLH}	Propagation Delay	0.40	1.75	0.40	1.65	0.40	1.75	ns	Figures 1, 2
t_{PHL}	$D_{na}-D_{ne}$ to O, \bar{O}								
t_{PLH}	Propagation Delay	1.00	2.60	1.00	2.60	1.15	3.20		
t_{PHL}	Data to F								
t_{TLH}	Transition Time	0.35	1.20	0.35	1.20	0.35	1.20	ns	
t_{THL}	20% to 80%, 80% to 20%								

PLCC AC Electrical Characteristics

$V_{EE} = -4.2V$ to $-5.7V$, $V_{CC} = V_{CCA} = GND$

Symbol	Parameter	$T_C = 0^\circ C$		$T_C = +25^\circ C$		$T_C = +85^\circ C$		Units	Conditions
		Min	Max	Min	Max	Min	Max		
t_{PLH}	Propagation Delay	0.40	1.55	0.40	1.45	0.40	1.55	ns	Figures 1, 2
t_{PHL}	$D_{na}-D_{ne}$ to O, \bar{O}								
t_{PLH}	Propagation Delay	1.00	2.40	1.00	2.40	1.15	3.00		
t_{PHL}	Data to F								
t_{TLH}	Transition Time	0.35	1.10	0.35	1.15	0.35	1.10	ns	
t_{THL}	20% to 80%, 80% to 20%								

Industrial Version**PLCC DC Electrical Characteristics** (Note 4)
 $V_{EE} = -4.2V$ to $-5.7V$, $V_{CC} = V_{CCA} = GND$, $T_C = -40^{\circ}C$ to $+85^{\circ}C$

Symbol	Parameter	$T_C = -40^{\circ}C$		$T_C = 0^{\circ}C$ to $+85^{\circ}C$		Units	Conditions
		Min	Max	Min	Max		
V_{OH}	Output HIGH Voltage	-1085	-870	-1025	-870	mV	$V_{IN} = V_{IH} (Max)$ or $V_{IL} (Min)$
V_{OL}	Output LOW Voltage	-1830	-1575	-1830	-1620		
V_{OHC}	Output HIGH Voltage	-1095		-1035		mV	$V_{IN} = V_{IH} (Min)$ or $V_{IL} (Max)$
V_{OLC}	Output LOW Voltage		-1565		-1610		
V_{IH}	Input HIGH Voltage	-1170	-870	-1165	-870	mV	Guaranteed HIGH Signal for All Inputs
V_{IL}	Input LOW Voltage	-1830	-1480	-1830	-1475		
I_{IL}	Input LOW Current	0.50		0.50		μA	$V_{IN} = V_{IL} (Min)$
I_{IH}	Input HIGH Current					μA	$V_{IN} = V_{IH} (Max)$
	$D_{2a}-D_{2e}$		250		250		
	$D_{1a}-D_{1e}$		350		350		
I_{EE}	Power Supply Current	-69	-30	-69	-30	mA	Inputs OPEN

Note 4: The specified limits represent the "worst case" value for the parameter. Since these values normally occur at the temperature extremes, additional noise immunity and guardbanding can be achieved by decreasing the allowable system operating ranges. Conditions for testing shown in the tables are chosen to guarantee operation under "worst case" conditions.

PLCC AC Electrical Characteristics
 $V_{EE} = -4.2V$ to $-5.7V$, $V_{CC} = V_{CCA} = GND$

Symbol	Parameter	$T_C = 40^{\circ}C$		$T_C = +25^{\circ}C$		$T_C = +85^{\circ}C$		Units	Conditions
		Min	Max	Min	Max	Min	Max		
t_{PLH}	Propagation Delay	0.35	1.55	0.40	1.45	0.40	1.55	ns	Figures 1, 2
t_{PHL}	$D_{na}-D_{ne}$ to O, \bar{O}								
t_{PLH}	Propagation Delay	1.00	2.40	1.00	2.40	1.15	3.00	ns	
t_{PHL}	Data to F								
t_{TLH}	Transition Time	0.35	1.10	0.35	1.15	0.35	1.10	ns	
t_{THL}	20% to 80%, 80% to 20%								

Test Circuitry

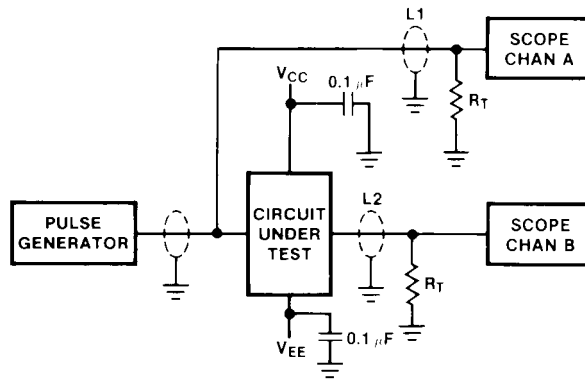

Notes:

- $V_{CC}, V_{CCA} = +2V, V_{EE} = -2.5V$
- L1 and L2 = equal length 50Ω impedance lines
- $R_T = 50\Omega$ terminator internal to scope
- Decoupling 0.1 μF from GND to V_{CC} and V_{EE}
- All unused outputs are loaded with 50Ω to GND
- C_L = Fixture and stray capacitance ≤ 3 pF

FIGURE 1. AC Test Circuit

Switching Waveforms

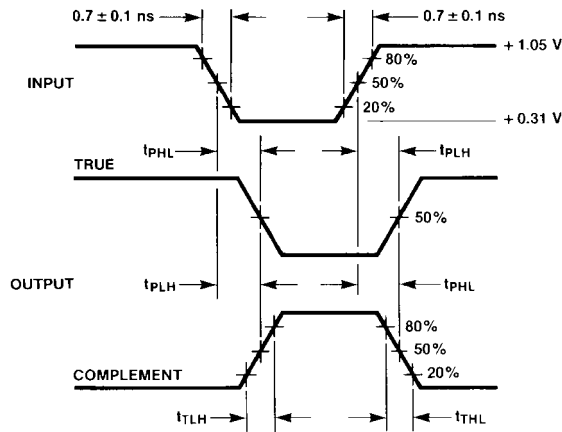
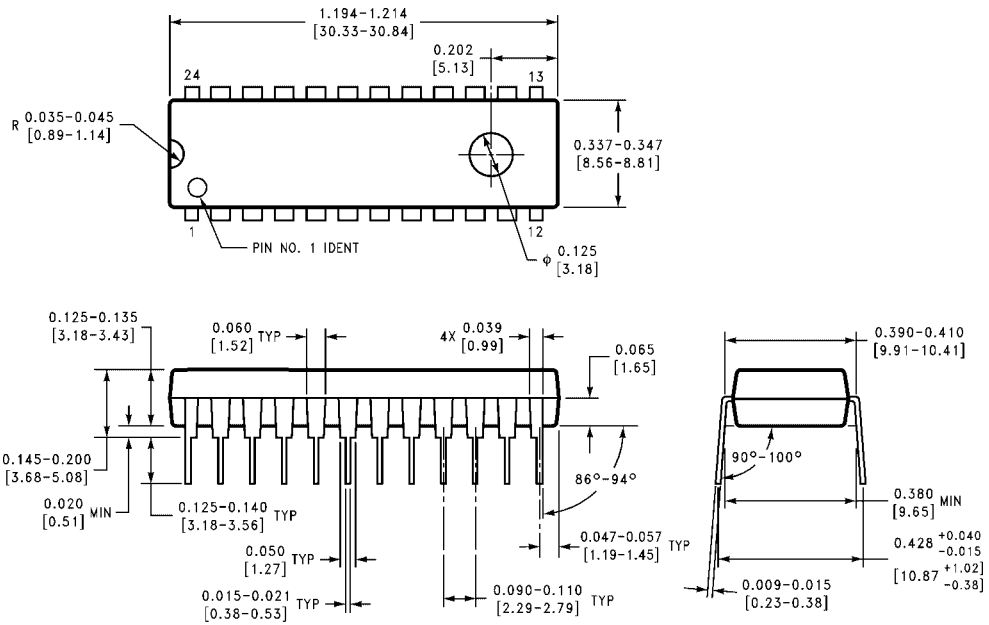

FIGURE 2. Propagation Delay and Transition Times

Physical Dimensions inches (millimeters) unless otherwise noted



**24-Lead Plastic Dual-In-Line Package (PDIP), JEDEC MS-010, 0.400 Wide
Package Number N24E**

N24E (REV A)

Physical Dimensions inches (millimeters) unless otherwise noted (Continued)

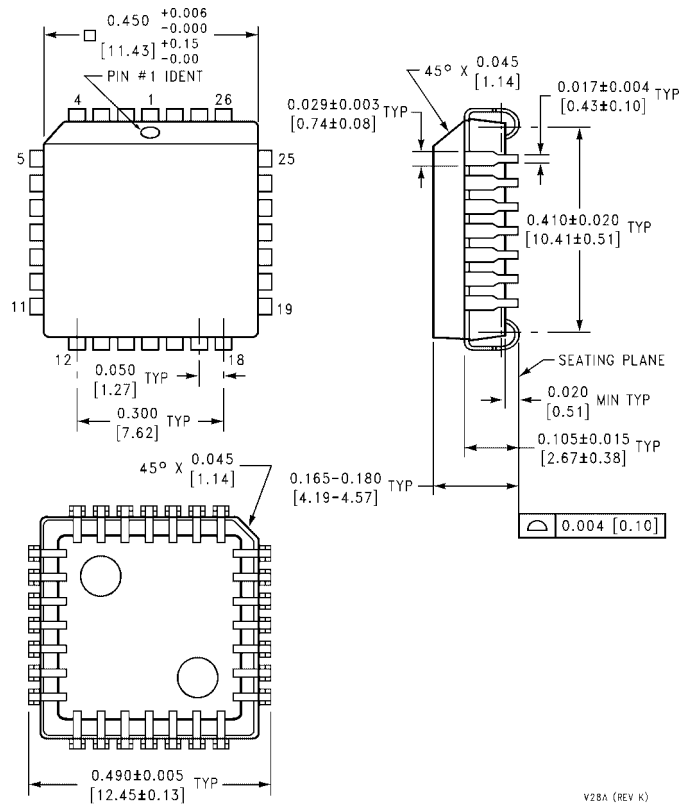

28-Lead Plastic Lead Chip Carrier (PLCC), JEDEC MO-047, 0.450 Square Package Number V28A

Fairchild does not assume any responsibility for use of any circuitry described, no circuit patent licenses are implied and Fairchild reserves the right at any time without notice to change said circuitry and specifications.

LIFE SUPPORT POLICY

FAIRCHILD'S PRODUCTS ARE NOT AUTHORIZED FOR USE AS CRITICAL COMPONENTS IN LIFE SUPPORT DEVICES OR SYSTEMS WITHOUT THE EXPRESS WRITTEN APPROVAL OF THE PRESIDENT OF FAIRCHILD SEMICONDUCTOR CORPORATION. As used herein:

1. Life support devices or systems are devices or systems which, (a) are intended for surgical implant into the body, or (b) support or sustain life, and (c) whose failure to perform when properly used in accordance with instructions for use provided in the labeling, can be reasonably expected to result in a significant injury to the user.
2. A critical component in any component of a life support device or system whose failure to perform can be reasonably expected to cause the failure of the life support device or system, or to affect its safety or effectiveness.

www.fairchildsemi.com

This datasheet has been downloaded from:

www.DatasheetCatalog.com

Datasheets for electronic components.



LittleDiode supplies new, hard to find or obsolete electronic components and semiconductors all over the world.

With over two million different components listed you are sure to find the part you need.

Feel free to visit us today at our online store:

LittleDiode.com

Looking forward to providing you with the best possible service.