

100328

Low Power Octal ECL/TTL Bi-Directional Translator with Latch

General Description

The 100328 is an octal latched bi-directional translator designed to convert TTL logic levels to 100K ECL logic levels and vice versa. The direction of this translation is determined by the DIR input. A LOW on the output enable input (OE) holds the ECL outputs in a cut-off state and the TTL outputs at a high impedance level. A HIGH on the latch enable input (LE) latches the data at both inputs even though only one output is enabled at the time. A LOW on LE makes the 100328 transparent.

The cut-off state is designed to be more negative than a normal ECL LOW level. This allows the output emitter-followers to turn off when the termination supply is $-2.0V$, presenting a high impedance to the data bus. This high impedance reduces termination power and prevents loss of low state noise margin when several loads share the bus.

The 100328 is designed with FAST® TTL output buffers, featuring optimal DC drive and capable of quickly charging and discharging highly capacitive loads. All inputs have 50 k Ω pull-down resistors.

Features

- Identical performance to the 100128 at 50% of the supply current
- Bi-directional translation
- 2000V ESD protection
- Latched outputs
- FAST TTL outputs
- 3-STATE outputs
- Voltage compensated operating range = $-4.2V$ to $-5.7V$
- Available to industrial grade temperature range

Ordering Code:

Order Number	Package Number	Package Description
100328SC	M24B	24-Lead Small Outline Integrated Circuit (SOIC), JEDEC MS-013, 0.300 Wide
100328PC	N24E	24-Lead Plastic Dual-In-Line Package (PDIP), JEDEC MS-010, 0.400 Wide
100328QC	V28A	28-Lead Plastic Lead Chip Carrier (PLCC), JEDEC MO-047, 0.450 Square
100328QI	V28A	28-Lead Plastic Lead Chip Carrier (PLCC), JEDEC MO-047, 0.450 Square Industrial Temperature Range ($-40^{\circ}C$ to $+85^{\circ}C$)

Devices also available in Tape and Reel. Specify by appending the suffix letter "X" to the ordering code.

Logic Symbol

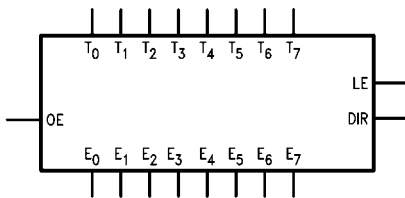

Pin Descriptions

Pin Names	Description
E_0-E_7	ECL Data I/O
T_0-T_7	TTL Data I/O
OE	Output Enable Input
LE	Latch Enable Input
DIR	Direction Control Input

All pins function at 100K ECL levels except for T_0-T_7 .

FAST® is a registered trademark of Fairchild Semiconductor Corporation.

Connection Diagrams

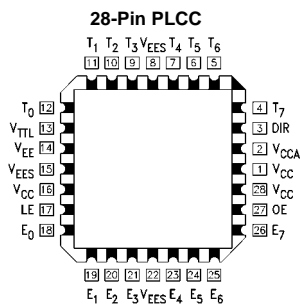
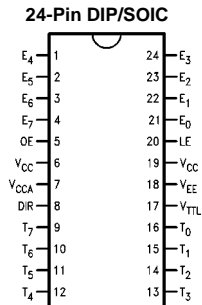

Functional Diagram

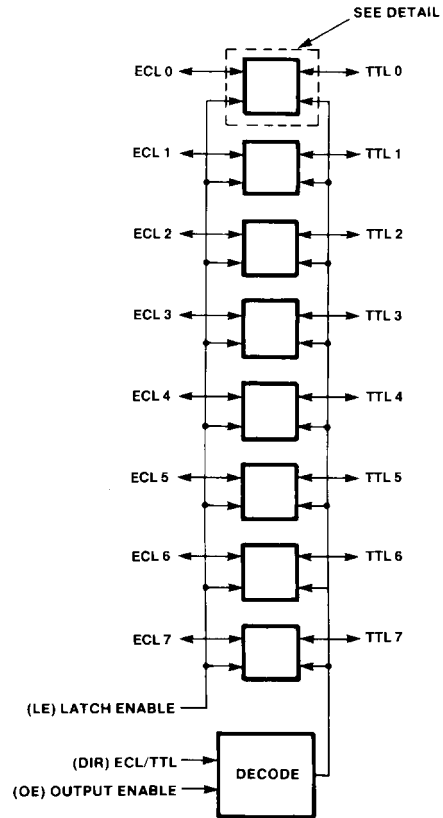

Note: LE, DIR, and OE use ECL logic levels

Truth Table

OE	DIR	LE	ECL Port	TTL Port	Notes
L	X	L	LOW (Cut-Off)	Z	
L	L	H	Input	Z	(Note 1)(Note 3)
L	H	H	LOW (Cut-Off)	Input	(Note 2)(Note 3)
H	L	L	L	L	(Note 1)(Note 4)
H	L	L	H	H	(Note 1)(Note 4)
H	L	H	X	Latched	(Note 1)(Note 3)
H	H	L	L	L	(Note 2)(Note 4)
H	H	L	H	H	(Note 2)(Note 4)
H	H	H	Latched	X	(Note 2)(Note 4)

H = HIGH Voltage Level
 L = LOW Voltage Level
 X = Don't Care
 Z = High Impedance

- Note 1: ECL input to TTL output mode.
- Note 2: TTL input to ECL output mode.
- Note 3: Retains data present before LE set HIGH.
- Note 4: Latch is transparent.

Detail

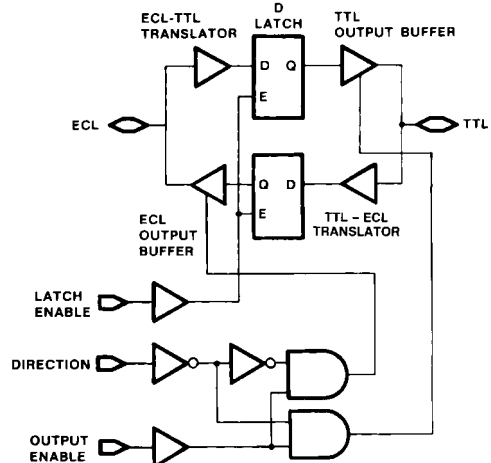

Absolute Maximum Ratings(Note 5)

Storage Temperature (T_{STG})	-65°C to +150°C
Maximum Junction Temperature (T_J)	+150°C
V_{EE} Pin Potential to Ground Pin	-7.0V to +0.5V
V_{TTL} Pin Potential to Ground Pin	-0.5V to +6.0V
ECL Input Voltage (DC)	V_{EE} to +0.5V
ECL Output Current (DC Output HIGH)	-50 mA
TTL Input Voltage (Note 6)	-0.5V to +6.0V
TTL Input Current (Note 6)	-30 mA to +5.0 mA
Voltage Applied to Output in HIGH State	
3-STATE Output	-0.5V to +5.5V
Current Applied to TTL Output in LOW State (Max)	twice the rated I_{OL} (mA)
ESD (Note 7)	$\geq 2000V$

Recommended Operating Conditions

Case Temperature (T_C)	Commercial	0°C to +85°C
	Industrial	-40°C to +85°C
ECL Supply Voltage (V_{EE})		-5.7V to -4.2V
TTL Supply Voltage (V_{TTL})		+4.5V to +5.5V

Note 5: The "Absolute Maximum Ratings" are those values beyond which the safety of the device cannot be guaranteed. The device should not be operated at these limits. The parametric values defined in the Electrical Characteristics tables are not guaranteed at the absolute maximum rating. The "Recommended Operating Conditions" table will define the conditions for actual device operation.

Note 6: Either voltage limit or current limit is sufficient to protect inputs.

Note 7: ESD testing conforms to MIL-STD-883, Method 3015.

Commercial Version**TTL-to-ECL DC Electrical Characteristics** (Note 8)

$V_{EE} = -4.2V$ to $-5.7V$, $V_{CC} = V_{CCA} = GND$, $T_C = 0^\circ C$ to $+85^\circ C$, $V_{TTL} = +4.5V$ to $+5.5V$

Symbol	Parameter	Min	Typ	Max	Units	Conditions
V_{OH}	Output HIGH Voltage	-1025	-955	-870	mV	$V_{IN} = V_{IH(Max)}$ or $V_{IL(Min)}$
V_{OL}	Output LOW Voltage	-1830	-1705	-1620	mV	Loading with 50Ω to $-2V$
	Cutoff Voltage		-2000	-1950	mV	OE or DIR LOW, $V_{IN} = V_{IH(Max)}$ or $V_{IL(Min)}$, Loading with 50Ω to $-2V$
V_{OHC}	Output HIGH Voltage Corner Point HIGH	-1035			mV	$V_{IN} = V_{IH(Min)}$ or $V_{IL(Max)}$ Loading with 50Ω to $-2V$
V_{OLC}	Output LOW Voltage Corner Point LOW			-1610	mV	
V_{IH}	Input HIGH Voltage	2.0		5.0	V	Over V_{TTL} , V_{EE} , T_C Range
V_{IL}	Input LOW Voltage	0		0.8	V	Over V_{TTL} , V_{EE} , T_C Range
I_{IH}	Input HIGH Current			70	μA	$V_{IN} = +2.7V$
	Breakdown Test			1.0	mA	$V_{IN} = +5.5V$
I_{IL}	Input LOW Current	-700			μA	$V_{IN} = +0.5V$
V_{FCD}	Input Clamp Diode Voltage	-1.2			V	$I_{IN} = -18 mA$
I_{EE}	V_{EE} Supply Current				mA	LE LOW, OE and DIR HIGH
						Inputs OPEN
		-159		-75		$V_{EE} = -4.2V$ to $-4.8V$
		-169		-75		$V_{EE} = -4.2V$ to $-5.7V$

Note 8: The specified limits represent the "worst case" value for the parameter. Since these values normally occur at the temperature extremes, additional noise immunity and guardbanding can be achieved by decreasing the allowable system operating ranges. Conditions for testing shown in the tables are chosen to guarantee operation under "worst case" conditions.

Commercial Version (Continued)
ECL-to-TTL DC Electrical Characteristics (Note 9)

$V_{EE} = -4.2V$ to $-5.7V$, $V_{CC} = V_{CCA} = GND$, $T_C = 0^\circ C$ to $+85^\circ C$, $C_L = 50$ pF, $V_{TTL} = +4.5V$ to $+5.5V$

Symbol	Parameter	Min	Typ	Max	Units	Conditions
V_{OH}	Output HIGH Voltage	2.7 2.4	3.1 2.9		V	$I_{OH} = -3$ mA, $V_{TTL} = 4.75V$ $I_{OH} = -3$ mA, $V_{TTL} = 4.50V$
V_{OL}	Output LOW Voltage		0.3	0.5	V	$I_{OL} = 24$ mA, $V_{TTL} = 4.50V$
V_{IH}	Input HIGH Voltage	-1165		-870	mV	Guaranteed HIGH Signal for All Inputs
V_{IL}	Input LOW Voltage	-1830		-1475	mV	Guaranteed LOW Signal for All Inputs
I_{IH}	Input HIGH Current			350	μA	$V_{IN} = V_{IH}$ (Max)
I_{IL}	Input LOW Current	0.50			μA	$V_{IN} = V_{IL}$ (Min)
I_{OZHT}	3-STATE Current Output HIGH			70	μA	$V_{OUT} = +2.7V$
I_{OZLT}	3-STATE Current Output LOW	-700			μA	$V_{OUT} = +0.5V$
I_{OS}	Output Short-Circuit Current	-150		-60	mA	$V_{OUT} = 0.0V$, $V_{TTL} = +5.5V$
I_{TTL}	V_{TTL} Supply Current			74 49 67	mA	TTL Outputs LOW TTL Outputs HIGH TTL Outputs in 3-STATE

DIP TTL-to-ECL AC Electrical Characteristics (Note 9)

$V_{EE} = -4.2V$ to $-5.7V$, $V_{TTL} = +4.5V$ to $+5.5V$, $V_{CC} = V_{CCA} = GND$

Symbol	Parameter	$T_C = 0^\circ C$		$T_C = 25^\circ C$		$T_C = 85^\circ C$		Units	Conditions
		Min	Max	Min	Max	Min	Max		
t_{PLH} t_{PHL}	T_N to E_n (Transparent)	1.1	3.5	1.1	3.6	1.1	3.8	ns	Figures 1, 2
t_{PLH} t_{PHL}	LE to E_n	1.7	3.6	1.7	3.7	1.9	3.9	ns	Figures 1, 2
t_{PZH}	OE to E_n (Cutoff to HIGH)	1.3	4.2	1.5	4.4	1.7	4.8	ns	Figures 1, 2
t_{PHZ}	OE to E_n (HIGH to Cutoff)	1.5	4.5	1.6	4.5	1.6	4.6	ns	Figures 1, 2
t_{PHZ}	DIR to E_n (HIGH to Cutoff)	1.6	4.3	1.6	4.3	1.7	4.5	ns	Figures 1, 2
t_{SET}	T_n to LE	1.1		1.1		1.1		ns	Figures 1, 2
t_{HOLD}	T_n to LE	1.1		1.1		1.1		ns	Figures 1, 2
$t_{PW(H)}$	Pulse Width LE	2.1		2.1		2.1		ns	Figures 1, 2
t_{TLH} t_{THL}	Transition Time 20% to 80%, 80% to 20%	0.6	1.6	0.6	1.6	0.6	1.6	ns	Figures 1, 2

Note 9: The specified limits represent the "worst" case value for the parameter. Since these values normally occur at the temperature extremes, additional noise immunity and guardbanding can be achieved by decreasing the allowable system operating ranges. Conditions for testing shown in the tables are chosen to guarantee operation under "worst case" conditions.

Commercial Version (Continued)									
DIP ECL-to-TTL AC Electrical Characteristics									
$V_{EE} = -4.2V$ to $-5.7V$, $V_{TTL} = +4.5V$ to $+5.5V$, $V_{CC} = V_{CCA} = GND$, $C_L = 50$ pF									
Symbol	Parameter	$T_C = 0^\circ C$		$T_C = 25^\circ C$		$T_C = 85^\circ C$		Units	Conditions
		Min	Max	Min	Max	Min	Max		
t_{PLH}	E_n to T_n	2.3	5.6	2.4	5.6	2.6	5.9	ns	Figures 3, 4
t_{PHL}	(Transparent)								
t_{PLH}	LE to T_n	3.1	7.2	3.1	7.2	3.3	7.7	ns	Figures 3, 4
t_{PHL}									
t_{PZH}	OE to T_n	3.4	8.45	3.7	8.95	4.0	9.7	ns	Figures 3, 5
t_{PZL}	(Enable Time)	3.8	9.2	4.0	9.2	4.3	9.95	ns	Figures 3, 5
t_{PHZ}	OE to T_n	3.2	8.95	3.3	8.95	3.5	9.2	ns	Figures 3, 5
t_{PLZ}	(Disable Time)	3.0	7.7	3.4	8.7	4.1	9.95	ns	Figures 3, 5
t_{PHZ}	DIR to T_n	2.7	8.2	2.8	8.7	3.1	8.95	ns	Figures 3, 6
t_{PLZ}	(Disable Time)	2.8	7.45	3.1	7.95	4.0	9.2	ns	Figures 3, 6
t_{SET}	E_n to LE	1.1		1.1		1.1		ns	Figures 3, 6
t_{HOLD}	E_n to LE	2.1		2.1		2.6		ns	Figures 3, 4
$t_{PW(H)}$	Pulse Width LE	4.1		4.1		4.1		ns	Figures 3, 7
SOIC and PLCC TTL-to-ECL AC Electrical Characteristics									
$V_{EE} = -4.2V$ to $-5.7V$, $V_{TTL} = +4.5V$ to $+5.5V$									
Symbol	Parameter	$T_C = 0^\circ C$		$T_C = 25^\circ C$		$T_C = 85^\circ C$		Units	Conditions
		Min	Max	Min	Max	Min	Max		
t_{PLH}	T_n to E_n	1.1	3.3	1.1	3.4	1.1	3.6	ns	Figures 1, 2
t_{PHL}	(Transparent)								
t_{PLH}	LE to E_n	1.7	3.4	1.7	3.5	1.9	3.7	ns	Figures 1, 2
t_{PHL}									
t_{PZH}	OE to E_n (Cutoff to HIGH)	1.3	4.0	1.5	4.2	1.7	4.6	ns	Figures 1, 2
t_{PHZ}	OE to E_n (HIGH to Cutoff)	1.5	4.3	1.6	4.3	1.6	4.4	ns	Figures 1, 2
t_{PHZ}	DIR to E_n (HIGH to Cutoff)	1.6	4.1	1.6	4.1	1.7	4.3	ns	Figures 1, 2
t_{SET}	T_n to LE	1.0		1.0		1.0		ns	Figures 1, 2
t_{HOLD}	T_n to LE	1.0		1.0		1.0		ns	Figures 1, 2
$t_{PW(H)}$	Pulse Width LE	2.0		2.0		2.0		ns	Figures 1, 2
t_{TLH}	Transition Time	0.6	1.6	0.6	1.6	0.6	1.6	ns	Figures 1, 2
t_{THL}	20% to 80%, 80% to 20%								
t_{OSHL}	Maximum Skew Common Edge Output-to-Output Variation Data to Output Path		200		200		200	ps	PLCC Only (Note 10)
t_{OSLH}	Maximum Skew Common Edge Output-to-Output Variation Data to Output Path		200		200		200	ps	PLCC Only (Note 10)
t_{OST}	Maximum Skew Opposite Edge Output-to-Output Variation Data to Output Path		650		650		650	ps	PLCC Only (Note 10)
t_{PS}	Maximum Skew Pin (Signal) Transition Variation Data to Output Path		650		650		650	ps	PLCC Only (Note 10)
<p>Note 10: Output-to-Output Skew is defined as the absolute value of the difference between the actual propagation delay for any outputs within the same packaged device. The specifications apply to any outputs switching in the same direction either HIGH-to-LOW (t_{OSHL}), or LOW-to-HIGH (t_{OSLH}), or in opposite directions both HL and LH (t_{OST}). Parameters t_{OST} and t_{PS} guaranteed by design.</p>									

Commercial Version (Continued)
SOIC and PLCC ECL-to-TTL AC Electrical Characteristics

$V_{EE} = -4.2V$ to $-5.7V$, $V_{TTL} = +4.5V$ to $+5.5V$, $C_L = 50$ pF

Symbol	Parameter	$T_C = 0^\circ C$		$T_C = 25^\circ C$		$T_C = 85^\circ C$		Units	Conditions
		Min	Max	Min	Max	Min	Max		
t_{PLH} t_{PHL}	E_n to T_n (Transparent)	2.3	5.4	2.4	5.4	2.6	5.7	ns	Figures 3, 4
t_{PLH} t_{PHL}	LE to T_n	3.1	7.0	3.1	7.0	3.3	7.5	ns	Figures 3, 4
t_{PZH} t_{PZL}	OE to T_n (Enable Time)	3.4	8.25	3.7	8.75	4.0	9.5	ns	Figures 3, 5
t_{PHZ} t_{PLZ}	OE to T_n (Disable Time)	3.2	8.75	3.3	8.75	3.5	9.0	ns	Figures 3, 5
t_{PHZ} t_{PLZ}	DIR to T_n (Disable Time)	2.7	8.0	2.8	8.5	3.1	8.75	ns	Figures 3, 6
t_{SET}	E_n to LE	1.0		1.0		1.0		ns	Figures 3, 4
t_{HOLD}	E_n to LE	2.0		2.0		2.5		ns	Figures 3, 4
$t_{PW(H)}$	Pulse Width LE	4.0		4.0		4.0		ns	Figures 3, 4
t_{OSHL}	Maximum Skew Common Edge Output-to-Output Variation Data to Output Path		600		600		600	ps	PLCC Only (Note 11)
t_{OSLH}	Maximum Skew Common Edge Output-to-Output Variation Data to Output Path		850		850		850	ps	PLCC Only (Note 11)
t_{OST}	Maximum Skew Opposite Edge Output-to-Output Variation Data to Output Path		1350		1350		1350	ps	PLCC Only (Note 11)
t_{PS}	Maximum Skew Pin (Signal) Transition Variation Data to Output Path		950		950		950	ps	PLCC Only (Note 11)

Note 11: Output-to-Output Skew is defined as the absolute value of the difference between the actual propagation delay for any outputs within the same packaged device. The specifications apply to any outputs switching in the same direction either HIGH-to-LOW (t_{OSHL}), or LOW-to-HIGH (t_{OSLH}), or in opposite directions both HL and LH (t_{OST}). Parameters t_{OST} and t_{PS} guaranteed by design.

Industrial Version**PLCC TTL-to-ECL DC Electrical Characteristics** (Note 12)
 $V_{EE} = -4.2V$ to $-5.7V$, $V_{CC} = V_{CCA} = GND$, $T_C = -40^\circ C$ to $+85^\circ C$, $V_{TTL} = +4.5V$ to $+5.5V$

Symbol	Parameter	$T_C = -40^\circ C$		$T_C = 0^\circ C$ to $+85^\circ C$		Units	Conditions
		Min	Max	Min	Max		
V_{OH}	Output HIGH Voltage	-1085	-870	-1025	-870	mV	$V_{IN} = V_{IH(Max)}$ or $V_{IL(Min)}$
V_{OL}	Output LOW Voltage	-1830	-1575	-1830	-1620	mV	Loading with 50Ω to $-2V$
	Cutoff Voltage		-1900		-1950	mV	OE or DIR LOW, $V_{IN} = V_{IH(Max)}$ or $V_{IL(Min)}$, Loading with 50Ω to $-2V$
V_{OHC}	Output HIGH Voltage Corner Point HIGH	-1095		-1035		mV	$V_{IN} = V_{IH(Min)}$ or $V_{IL(Max)}$ Loading with 50Ω to $-2V$
V_{OLC}	Output LOW Voltage Corner Point LOW		-1565		-1610	mV	
V_{IH}	Input HIGH Voltage	2.0	5.0	2.0	5.0	V	Over V_{TTL} , V_{EE} , T_C Range
V_{IL}	Input LOW Voltage	0	0.8	0	0.8	V	Over V_{TTL} , V_{EE} , T_C Range
I_{IH}	Input HIGH Current		70		70	μA	$V_{IN} = +2.7V$
	Breakdown Test		1.0		1.0	mA	$V_{IN} = +5.5V$
I_{IL}	Input LOW Current	-700		-700		μA	$V_{IN} = +0.5V$
V_{FCD}	Input Clamp Diode Voltage	-1.2		-1.2		V	$I_{IN} = -18 mA$
I_{EE}	V_{EE} Supply Current					mA	LE LOW, OE and DIR HIGH Inputs OPEN $V_{EE} = -4.2V$ to $-4.8V$ $V_{EE} = -4.2V$ to $-5.7V$
		-159	-70	-159	-75		
		-169	-70	-169	-75		

PLCC ECL-to-TTL DC Electrical Characteristics (Note 12)
 $V_{EE} = -4.2V$ to $-5.7V$, $V_{CC} = V_{CCA} = GND$, $T_C = -40^\circ C$ to $+85^\circ C$, $C_L = 50 pF$, $V_{TTL} = +4.5V$ to $+5.5V$

Symbol	Parameter	$T_C = -40^\circ C$		$T_C = 0^\circ C$ to $+85^\circ C$		Units	Conditions
		Min	Max	Min	Max		
V_{OH}	Output HIGH Voltage	2.7		2.7		V	$I_{OH} = -3 mA$, $V_{TTL} = 4.75V$ $I_{OH} = -3 mA$, $V_{TTL} = 4.50V$
		2.4		2.4			
V_{OL}	Output LOW Voltage		0.5		0.5	V	$I_{OL} = 24 mA$, $V_{TTL} = 4.50V$
V_{IH}	Input HIGH Voltage	-1170	-870	-1165	-870	mV	Guaranteed HIGH Signal for All Inputs
V_{IL}	Input LOW Voltage	-1830	-1480	-1830	-1475	mV	Guaranteed LOW Signal for All Inputs
I_{IH}	Input HIGH Current		425		350	μA	$V_{IN} = V_{IH} (Max)$
I_{IH}	Input LOW Current	0.50		0.50		μA	$V_{IN} = V_{IH} (Min)$
I_{OZHT}	3-STATE Current Output HIGH		70		70	μA	$V_{OUT} = +2.7V$
I_{OZLT}	3-STATE Current Output LOW	-700		-700		μA	$V_{OUT} = +0.5V$
I_{OS}	Output Short-Circuit Current	-150	-60	-150	-60	mA	$V_{OUT} = 0.0V$, $V_{TTL} = +5.5V$
I_{TTL}	V_{TTL} Supply Current		74		74	mA	TTL Outputs LOW
			49		49		TTL Outputs HIGH
			67		67		TTL Outputs in 3-STATE

Note 12: The specified limits represent the "worst case" value for the parameter. Since these values normally occur at the temperature extremes, additional noise immunity and guardbanding can be achieved by decreasing the allowable system operating ranges. Conditions for testing shown in the tables are chosen to guarantee operation under "worst case" conditions.

Industrial Version (Continued) PLCC TTL-to-ECL AC Electrical Characteristics

 $V_{EE} = -4.2V$ to $-5.7V$, $V_{TTL} = +4.5V$ to $+5.5V$

Symbol	Parameter	$T_C = -40^\circ C$		$T_C = 25^\circ C$		$T_C = 85^\circ C$		Units	Conditions
		Min	Max	Min	Max	Min	Max		
t_{PLH} t_{PHL}	T_n to E_n (Transparent)	1.0	3.3	1.1	3.4	1.1	3.6	ns	Figures 1, 2
t_{PLH} t_{PHL}	LE to E_n	1.7	3.4	1.7	3.5	1.9	3.7	ns	Figures 1, 2
t_{PZH}	OE to E_n (Cutoff to HIGH)	1.2	4.0	1.5	4.2	1.7	4.6	ns	Figures 1, 2
t_{PHZ}	OE to E_n (HIGH to Cutoff)	1.5	4.5	1.6	4.3	1.6	4.4	ns	Figures 1, 2
t_{PHZ}	DIR to E_n (HIGH to Cutoff)	1.6	4.1	1.6	4.1	1.7	4.3	ns	Figures 1, 2
t_{SET}	T_n to LE	2.5		1.0		1.0		ns	Figures 1, 2
t_{HOLD}	T_n to LE	1.0		1.0		1.0		ns	Figures 1, 2
$t_{PW(H)}$	Pulse Width LE	2.5		2.0		2.0		ns	Figures 1, 2
t_{TLH} t_{THL}	Transition Time 20% to 80%, 80% to 20%	0.4	2.3	0.6	1.6	0.6	1.6	ns	Figures 1, 2

PLCC ECL-to-TTL AC Electrical Characteristics

 $V_{EE} = -4.2V$ to $-5.7V$, $V_{TTL} = +4.5V$ to $+5.5V$, $C_L = 50$ pF

Symbol	Parameter	$T_C = 0^\circ C$		$T_C = 25^\circ C$		$T_C = 85^\circ C$		Units	Conditions
		Min	Max	Min	Max	Min	Max		
t_{PLH} t_{PHL}	E_n to T_n (Transparent)	2.3	5.4	2.4	5.4	2.6	5.7	ns	Figures 3, 4
t_{PLH} t_{PHL}	LE to T_n	3.1	7.4	3.1	7.0	3.3	7.5	ns	Figures 3, 4
t_{PZH} t_{PZL}	OE to T_n (Enable Time)	3.4	8.3	3.7	8.75	4.0	9.5	ns	Figures 3, 5
t_{PHZ} t_{PLZ}	OE to T_n (Disable Time)	3.2	9.0	3.3	8.75	3.5	9.0	ns	Figures 3, 5
t_{PHZ} t_{PLZ}	DIR to T_n (Disable Time)	2.7	8.0	2.8	8.5	3.1	8.75	ns	Figures 3, 5
t_{SET}	E_n to LE	2.5		1.0		1.0		ns	Figures 3, 4
t_{HOLD}	E_n to LE	2.3		2.0		2.5		ns	Figures 3, 4
$t_{PW(H)}$	Pulse Width LE	4.0		4.0		4.0		ns	Figures 3, 4

Test Circuitry (TTL-to-ECL)

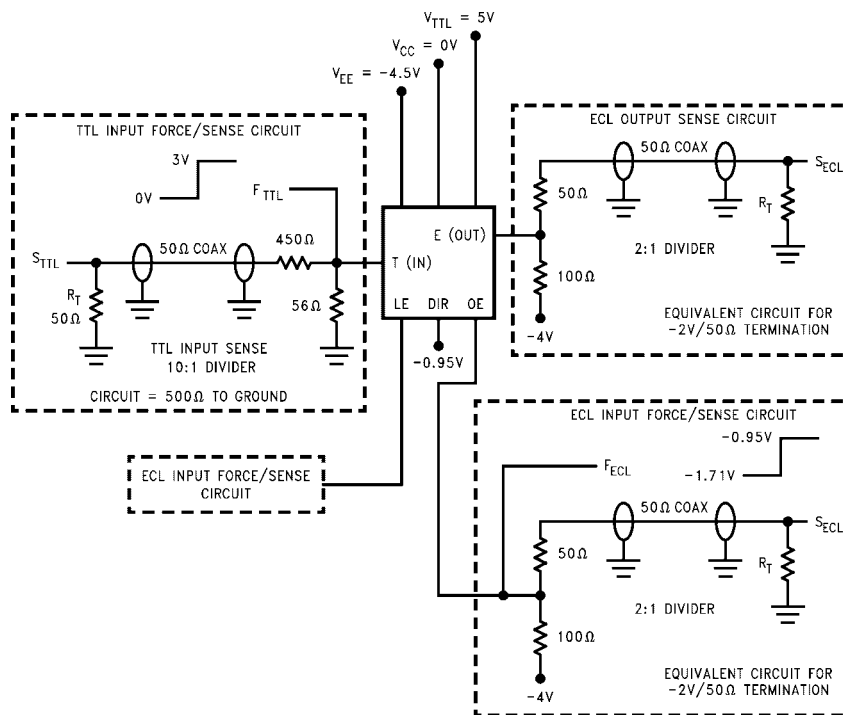

- Note:**
- $R_T = 50\Omega$ termination. When an input or output is being monitored by a scope, R_T is supplied by the scope's 50Ω resistance. When an input or output is not being monitored, an external 50Ω resistance must be applied to serve as R_T .
 - TTL and ECL force signals are brought to the DUT via 50Ω coax lines.
 - V_{TTL} is decoupled to ground with $0.1\ \mu\text{F}$ and V_{EE} is decoupled to ground with $0.01\ \mu\text{F}$ and V_{CC} is connected to ground.
 - For ECL input pins, the equivalent force/sense circuitry is optional.

FIGURE 1. TTL-to-ECL AC Test Circuit

Switching Waveforms (TTL-to-ECL)

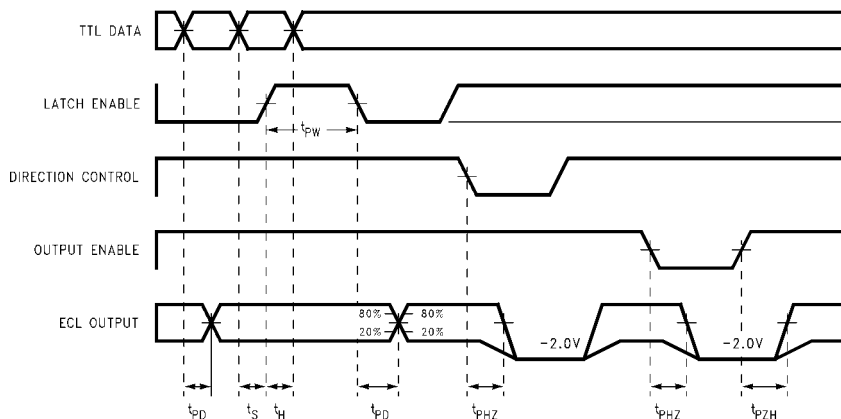
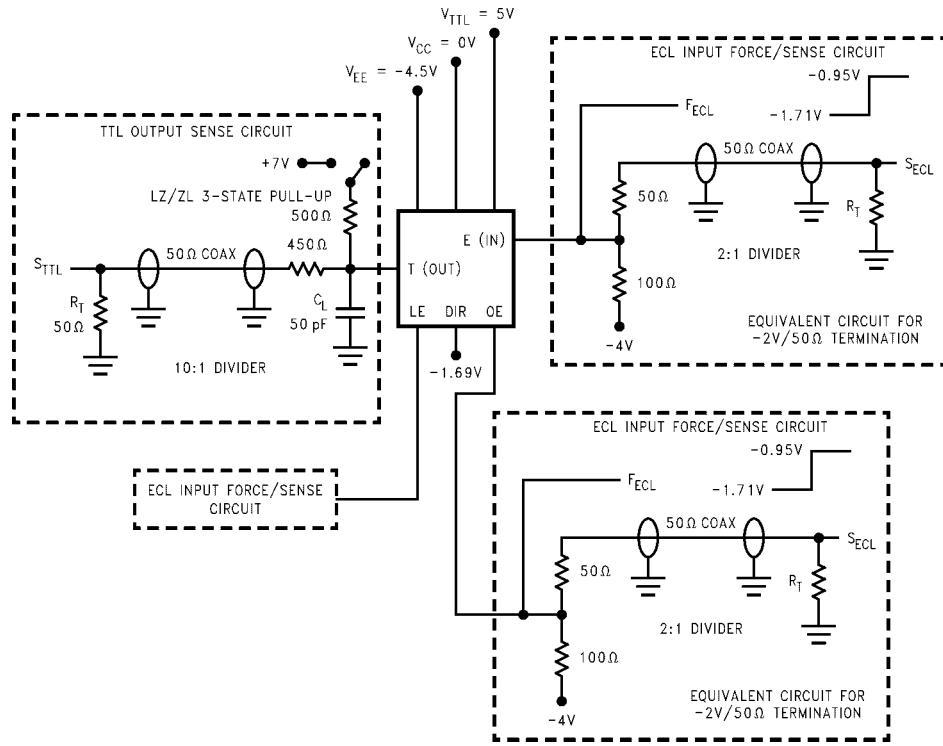

FIGURE 2. TTL to ECL Transition—Propagation Delay and Transition Times

Test Circuitry (ECL-to-TTL)



Note:

- $R_T = 50\Omega$ termination. When an input or output is being monitored by a scope, R_T is supplied by the scope's 50Ω resistance. When an input or output is not being monitored, an external 50Ω resistance must be applied to serve as R_T .
- The TTL 3-State pull up switch is connected to +7V only for ZL and LZ tests.
- TTL and ECL force signals are brought to the DUT via 50Ω coax lines.
- V_{TTL} is decoupled to ground with $0.1\ \mu\text{F}$, V_{EE} is decoupled to ground with $0.01\ \mu\text{F}$ and V_{CC} is connected to ground.

FIGURE 3. ECL-to-TTL AC Test Circuit

Switching Waveforms (ECL-to-TTL)

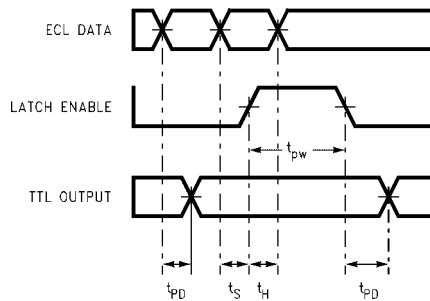

Note: DIR is LOW, and OE is HIGH

FIGURE 4. ECL-to-TTL Transition—Propagation Delay and Transition Times

Switching Waveforms (ECL-to-TTL) (Continued)

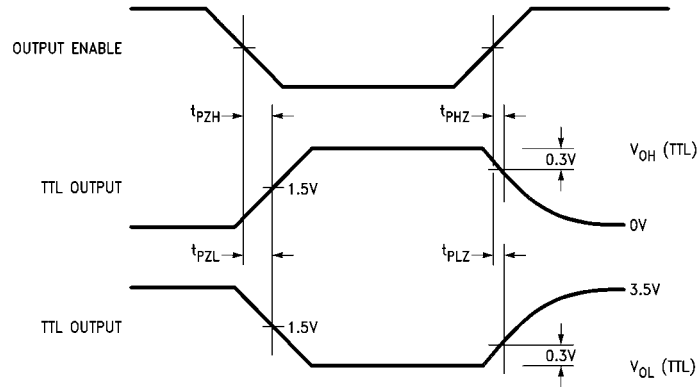

Note: DIR is LOW, LE is HIGH

FIGURE 5. ECL-to-TTL Transition, OE to TTL Output, Enable and Disable Times

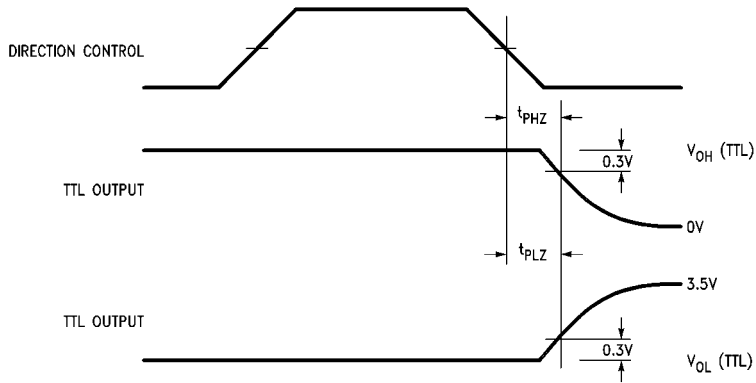

Note: OE is HIGH, LE is HIGH

FIGURE 6. ECL-to-TTL Transition, DIR to TTL Output, Disable Time

Applications

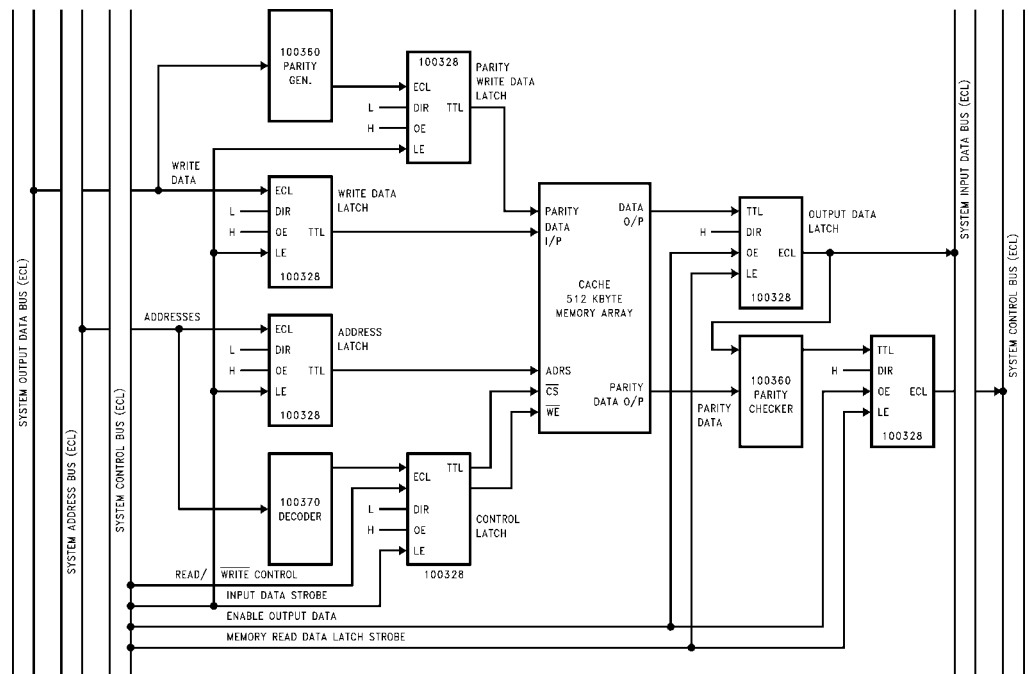
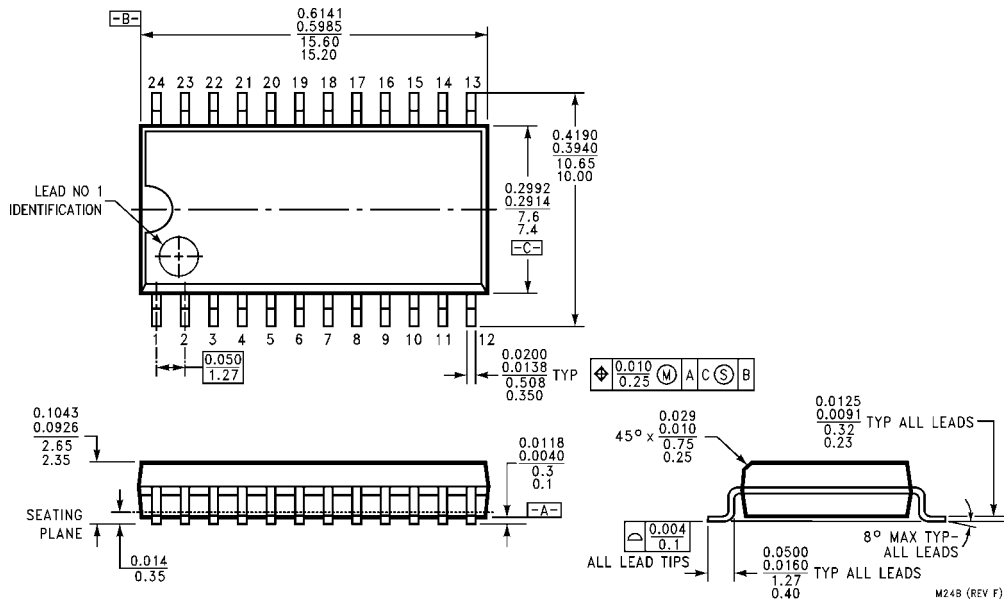
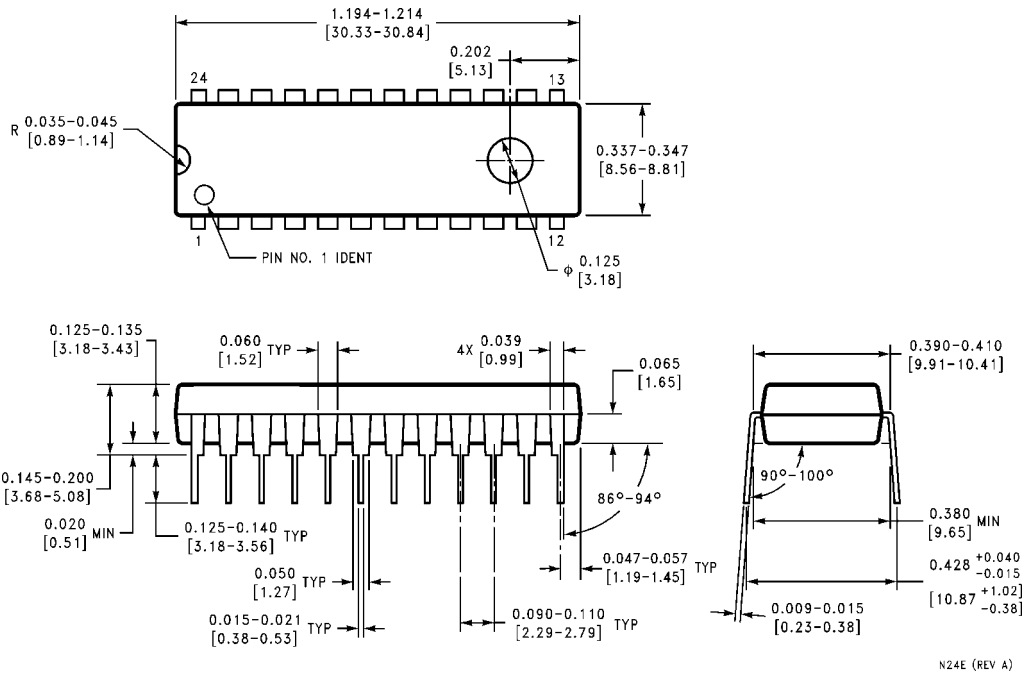

FIGURE 7. Applications Diagram—MOS/TTL SRAM Interface Using 100328 ECL–TTL Latched Translator

Physical Dimensions inches (millimeters) unless otherwise noted



**24-Lead Small Outline Integrated Circuit (SOIC), JEDEC MS-013, 0.300 Wide
Package Number M24B**



**24-Lead Plastic Dual-In-Line Package (PDIP), JEDEC MS-010, 0.400 Wide
Package Number N24E**

Physical Dimensions inches (millimeters) unless otherwise noted (Continued)

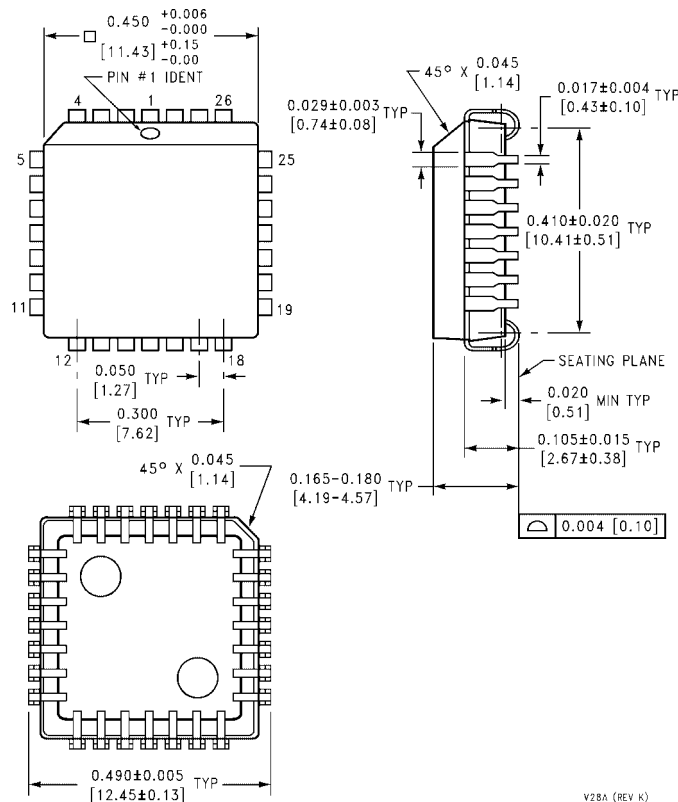

V28A (REV K)

28-Lead Plastic Lead Chip Carrier (PLCC), JEDEC MO-047, 0.450 Square Package Number V28A

Fairchild does not assume any responsibility for use of any circuitry described, no circuit patent licenses are implied and Fairchild reserves the right at any time without notice to change said circuitry and specifications.

LIFE SUPPORT POLICY

FAIRCHILD'S PRODUCTS ARE NOT AUTHORIZED FOR USE AS CRITICAL COMPONENTS IN LIFE SUPPORT DEVICES OR SYSTEMS WITHOUT THE EXPRESS WRITTEN APPROVAL OF THE PRESIDENT OF FAIRCHILD SEMICONDUCTOR CORPORATION. As used herein:

1. Life support devices or systems are devices or systems which, (a) are intended for surgical implant into the body, or (b) support or sustain life, and (c) whose failure to perform when properly used in accordance with instructions for use provided in the labeling, can be reasonably expected to result in a significant injury to the user.
2. A critical component in any component of a life support device or system whose failure to perform can be reasonably expected to cause the failure of the life support device or system, or to affect its safety or effectiveness.

www.fairchildsemi.com

This datasheet has been downloaded from:

www.DatasheetCatalog.com

Datasheets for electronic components.



LittleDiode supplies new, hard to find or obsolete electronic components and semiconductors all over the world.

With over two million different components listed you are sure to find the part you need.

Feel free to visit us today at our online store:

LittleDiode.com

Looking forward to providing you with the best possible service.