

# 100341 Low Power 8-Bit Shift Register

## General Description

The 100341 contains eight edge-triggered, D-type flip-flops with individual inputs ( $P_n$ ) and outputs ( $Q_n$ ) for parallel operation, and with serial inputs ( $D_n$ ) and steering logic for bidirectional shifting. The flip-flops accept input data a setup time before the positive-going transition of the clock pulse and their outputs respond a propagation delay after this rising clock edge.

The circuit operating mode is determined by the Select inputs  $S_0$  and  $S_1$ , which are internally decoded to select either "parallel entry", "hold", "shift left" or "shift right" as described in the Truth Table. All inputs have 50 k $\Omega$  pull-down resistors.

## Features

- 35% power reduction of the 100141
- 2000V ESD protection
- Pin/function compatible with 100141
- Voltage compensated operating range = -4.2V to -5.7V
- Available to industrial grade temperature range

## Ordering Code:

Order Number	Package Number	Package Description
10034SC	M24B	24-Lead Small Outline Integrated Circuit (SOIC), JEDEC MS-013, 0.300 Wide
100341PC	N24E	24-Lead Plastic Dual-In-Line Package (PDIP), JEDEC MS-010, 0.400 Wide
100341QI	V28A	28-Lead Plastic Lead Chip Carrier (PLCC), JEDEC MO-047, 0.450 Square
100341QC	V28A	28-Lead Plastic Lead Chip Carrier (PLCC), JEDEC MO-047, 0.450 Square Industrial Temperature Range (-40°C to +85°C)

Devices also available in Tape and Reel. Specify by appending the suffix letter "X" to the ordering code.

## Logic Symbol

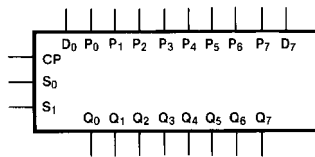

## Connection Diagrams

24-Pin DIP/SOIC

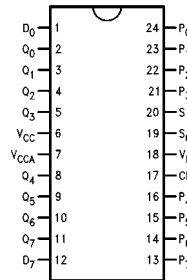

## Pin Descriptions

Pin Names	Description
CP	Clock Input
$S_0, S_1$	Select Inputs
$D_0, D_7$	Serial Inputs
$P_0-P_7$	Parallel Inputs
$Q_0-Q_7$	Data Outputs

28-Pin PLCC

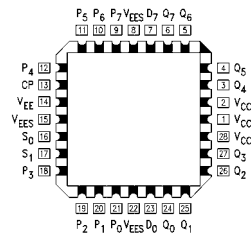

### Truth Table

Function	Inputs					Outputs							
	D <sub>7</sub>	D <sub>0</sub>	S <sub>1</sub>	S <sub>0</sub>	CP	Q <sub>7</sub>	Q <sub>6</sub>	Q <sub>5</sub>	Q <sub>4</sub>	Q <sub>3</sub>	Q <sub>2</sub>	Q <sub>1</sub>	Q <sub>0</sub>
Load Register	X	X	L	L	↗	P <sub>7</sub>	P <sub>6</sub>	P <sub>5</sub>	P <sub>4</sub>	P <sub>3</sub>	P <sub>2</sub>	P <sub>1</sub>	P <sub>0</sub>
Shift Left	X	L	L	H	↗	Q <sub>6</sub>	Q <sub>5</sub>	Q <sub>4</sub>	Q <sub>3</sub>	Q <sub>2</sub>	Q <sub>1</sub>	Q <sub>0</sub>	L
Shift Left	X	H	L	H	↗	Q <sub>6</sub>	Q <sub>5</sub>	Q <sub>4</sub>	Q <sub>3</sub>	Q <sub>2</sub>	Q <sub>1</sub>	Q <sub>0</sub>	H
Shift Right	L	X	H	L	↗	L	Q <sub>7</sub>	Q <sub>6</sub>	Q <sub>5</sub>	Q <sub>4</sub>	Q <sub>3</sub>	Q <sub>2</sub>	Q <sub>1</sub>
Shift Right	H	X	H	L	↗	H	Q <sub>7</sub>	Q <sub>6</sub>	Q <sub>5</sub>	Q <sub>4</sub>	Q <sub>3</sub>	Q <sub>2</sub>	Q <sub>1</sub>
Hold	X	X	H	H	X	No Change							
Hold	X	X	X	X	H								
Hold	X	X	X	X	L								

H = HIGH Voltage Level  
 L = LOW Voltage Level  
 X = Don't Care  
 ↗ = LOW-to-HIGH Transition

### Logic Diagram

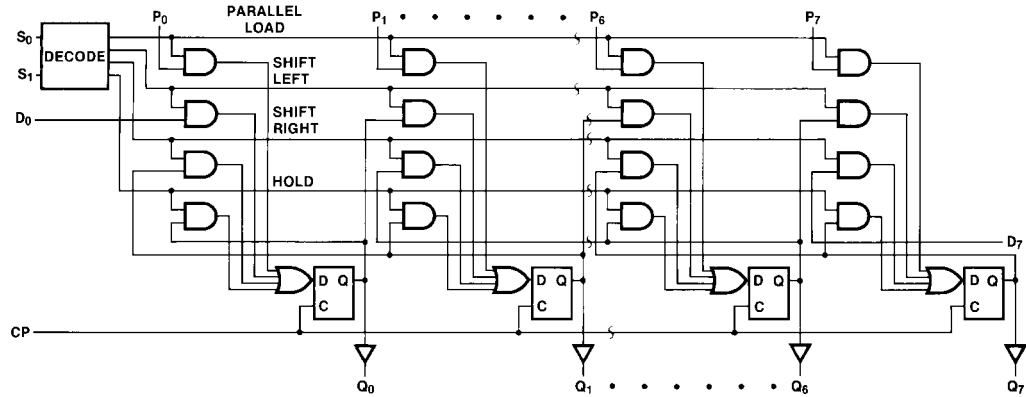

**Absolute Maximum Ratings**(Note 1)

Storage Temperature ( $T_{STG}$ )	-65°C to +150°C
Maximum Junction Temperature ( $T_J$ )	+150°C
$V_{EE}$ Pin Potential to Ground Pin	-7.0V to +0.5V
Input Voltage (DC)	$V_{EE}$ to +0.5V
Output Current (DC Output HIGH)	-50 mA
ESD (Note 2)	≥2000V

**Recommended Operating Conditions**

Case Temperature ( $T_C$ )	Commercial	0°C to +85°C
	Industrial	-40°C to +85°C
Supply Voltage ( $V_{EE}$ )		-5.7V to -4.2V

**Note 1:** The "Absolute Maximum Ratings" are those values beyond which the safety of the device cannot be guaranteed. The device should not be operated at these limits. The parametric values defined in the Electrical Characteristics tables are not guaranteed at the absolute maximum rating. The "Recommended Operating Conditions" table will define the conditions for actual device operation.

**Note 2:** ESD testing conforms to MIL-STD-883, Method 3015.

**Commercial Version****DC Electrical Characteristics** (Note 3)

$V_{EE} = -4.2V$  to  $-5.7V$ ,  $V_{CC} = V_{CCA} = GND$ ,  $T_C = 0^\circ C$  to  $+85^\circ C$

Symbol	Parameter	Min	Typ	Max	Units	Conditions	
$V_{OH}$	Output HIGH Voltage	-1025	-955	-870	mV	$V_{IN} = V_{IH}$ (Max) or $V_{IL}$ (Min)	Loading with 50Ω to -2.0V
$V_{OL}$	Output LOW Voltage	-1830	-1705	-1620	mV		
$V_{OHC}$	Output HIGH Voltage	-1035			mV	$V_{IN} = V_{IH}$ (Min) or $V_{IL}$ (Max)	Loading with 50Ω to -2.0V
$V_{OLC}$	Output LOW Voltage			-1610	mV		
$V_{IH}$	Input HIGH Voltage	-1165		-870	mV	Guaranteed HIGH Signal for all Inputs	
$V_{IL}$	Input LOW Voltage	-1830		-1475	mV	Guaranteed LOW Signal for all Inputs	
$I_{IL}$	Input LOW Current	0.50			μA	$V_{IN} = V_{IL}$ (Min)	
$I_{IH}$	Input HIGH Current			240	μA	$V_{IN} = V_{IH}$ (Max)	
$I_{EE}$	Power Supply Current	-157 -167		-75 -75	mA mA	Inputs OPEN $V_{EE} = -4.2V$ to $-4.8V$ $V_{EE} = -4.2V$ to $-5.7V$	

**Note 3:** The specified limits represent the "worst case" value for the parameter. Since these values normally occur at the temperature extremes, additional noise immunity and guardbanding can be achieved by decreasing the allowable system operating ranges. Conditions for testing shown in the tables are chosen to guarantee operation under "worst case" conditions.

**DIP AC Electrical Characteristics**

$V_{EE} = -4.2V$  to  $-5.7V$ ,  $V_{CC} = V_{CCA} = GND$

Symbol	Parameter	$T_C = 0^\circ C$		$T_C = +25^\circ C$		$T_C = +85^\circ C$		Units	Conditions
		Min	Max	Min	Max	Min	Max		
$f_{MAX}$	Max Clock Frequency	400		400		400		MHz	Figures 2, 3
$t_{PLH}$	Propagation Delay	0.90	1.90	1.00	2.00	1.00	2.10	ns	Figures 1, 3 (Note 4)
$t_{PHL}$	CP to Output								
$t_{TLH}$	Transition Time	0.35	1.30	0.35	1.30	0.35	1.30	ns	Figures 1, 3
$t_{THL}$	20% to 80%, 80% to 20%								
$t_S$	Setup Time	$D_n, P_n$ 1.60		0.65 1.60		0.65 1.60		ns	Figure 4
$t_H$	Hold	$D_n, P_n$ 0.60		0.80 0.60		0.80 0.60		ns	
$t_{PW(H)}$	Pulse Width HIGH	CP	2.00	2.00		2.00		ns	Figure 3

**Note 4:** The propagation delay specified is for the switching of a single output. Delays may vary up to 0.40 ns if multiple outputs are switching simultaneously.

### Commercial Version (Continued) SOIC and PLCC AC Electrical Characteristics

 $V_{EE} = -4.2V$  to  $-5.7V$ ,  $V_{CC} = V_{CCA} = GND$ 

Symbol	Parameter	$T_C = 0^\circ C$		$T_C = +25^\circ C$		$T_C = +85^\circ C$		Units	Conditions
		Min	Max	Min	Max	Min	Max		
$f_{MAX}$	Maximum Clock Frequency	425		425		425		MHz	Figures 2, 3
$t_{PLH}$	Propagation Delay	0.90	1.70	1.00	1.80	1.00	1.90	ns	Figures 1, 3 (Note 5)
$t_{PHL}$	CP to Output								
$t_{TLH}$	Transition Time	0.35	1.20	0.35	1.20	0.35	1.20	ns	Figures 1, 3
$t_{THL}$	20% to 80%, 80% to 20%								
$t_S$	Setup Time	$D_n, P_n$ 1.50		0.55 1.50		0.55 1.50		ns	Figure 4
$t_H$	Hold Time	$D_n, P_n$ 0.50		0.70 0.50		0.70 0.50		ns	
$t_{PW(H)}$	Pulse Width HIGH CP	2.00		2.00		2.00		ns	Figure 3
$t_{OSHL}$	Maximum Skew Common Edge Output-to-Output Variation Clock to Output Path		200		200		200	ps	PLCC Only (Note 6)
$t_{OSLH}$	Maximum Skew Common Edge Output-to-Output Variation Clock to Output Path		200		200		200	ps	PLCC Only (Note 6)
$t_{OST}$	Maximum Skew Opposite Edge Output-to-Output Variation Clock to Output Path		250		250		250	ps	PLCC Only (Note 6)
$t_{ps}$	Maximum Skew Pin (Signal) Transition Variation Clock to Output Path		250		250		250	ps	PLCC Only (Note 6)

**Note 5:** The propagation delay specified is for the switching of a single output. Delays may vary up to 0.40 ns if multiple outputs are switching simultaneously.

**Note 6:** Output-to-Output Skew is defined as the absolute value of the difference between the actual propagation delay for any outputs within the same packaged device. The specifications apply to any outputs switching in the same direction either HIGH-to-LOW ( $t_{OSHL}$ ), or LOW-to-HIGH ( $t_{OSLH}$ ), or in opposite directions both HL and LH ( $t_{OST}$ ). Parameters  $t_{OST}$  and  $t_{ps}$  guaranteed by design

**Industrial Version****PLCC DC Electrical Characteristics** (Note 7)
 $V_{EE} = -4.2V$  to  $-5.7V$ ,  $V_{CC} = V_{CCA} = GND$ ,  $T_C = -40^\circ C$  to  $+85^\circ C$ 

Symbol	Parameter	$T_C = -40^\circ C$		$T_C = 0^\circ C$ to $+85^\circ C$		Units	Conditions
		Min	Max	Min	Max		
$V_{OH}$	Output HIGH Voltage	-1085	-870	-1025	-870	mV	$V_{IN} = V_{IH}(\text{Max})$ Loading with $50\Omega$ to $-2.0V$
$V_{OL}$	Output LOW Voltage	-1830	-1575	-1830	-1620	mV	or $V_{IL}(\text{Min})$
$V_{OHC}$	Output HIGH Voltage	-1095		-1035		mV	$V_{IN} = V_{IH}(\text{Min})$ Loading with $50\Omega$ to $-2.0V$
$V_{OLC}$	Output LOW Voltage		-1565		-1610	mV	or $V_{IL}(\text{Max})$
$V_{IH}$	Input HIGH Voltage	-1170	-870	-1165	-870	mV	Guaranteed HIGH Signal for all Inputs
$V_{IL}$	Input LOW Voltage	-1830	-1480	-1830	-1475	mV	Guaranteed LOW Signal for all Inputs
$I_{IL}$	Input LOW Current	0.50		0.50		$\mu A$	$V_{IN} = V_{IL}(\text{Min})$
$I_{IH}$	Input HIGH Current		240		240	$\mu A$	$V_{IN} = V_{IH}(\text{Max})$
$I_{EE}$	Power Supply Current	-157	-75	-157	-75	mA	Inputs OPEN $V_{EE} = -4.2V$ to $-4.8V$
		-167	-75	-167	-75	mA	$V_{EE} = -4.2V$ to $-5.7V$

**Note 7:** The specified limits represent the "worst case" value for the parameter. Since these values normally occur at the temperature extremes, additional noise immunity and guardbanding can be achieved by decreasing the allowable system operating ranges. Conditions for testing shown in the tables are chosen to guarantee operation under "worst case" conditions.

**PLCC AC Electrical Characteristics**
 $V_{EE} = -4.2V$  to  $-5.7V$ ,  $V_{CC} = V_{CCA} = GND$ 

Symbol	Parameter	$T_C = -40^\circ C$		$T_C = +25^\circ C$		$T_C = +85^\circ C$		Units	Conditions
		Min	Max	Min	Max	Min	Max		
$f_{MAX}$	Max Clock Frequency	425		425		425		MHz	Figures 2, 3
$t_{PLH}$	Propagation Delay	0.90	1.80	1.00	1.80	1.00	1.90	ns	Figures 1, 3 (Note 8)
$t_{PHL}$	CP to Output								
$t_{TLH}$	Transition Time	0.30	1.90	0.35	1.20	0.35	1.20	ns	Figures 1, 3
$t_{THL}$	20% to 80%, 80% to 20%								
$t_S$	Setup Time	$D_n, P_n$	0.60	0.55	0.55	0.55		ns	Figure 4
		$S_n$	1.70	1.50	1.50				
$t_H$	Hold Time	$D_n, P_n$	0.90	0.70	0.70	0.70		ns	
		$S_n$	0.50	0.50	0.50				
$t_{PW(H)}$	Pulse Width HIGH	CP	2.00	2.00	2.00	2.00		ns	Figure 3

**Note 8:** The propagation delay specified is for the switching of a single output. Delays may vary up to 0.40 ns if multiple outputs are switching simultaneously.

**Test Circuitry**

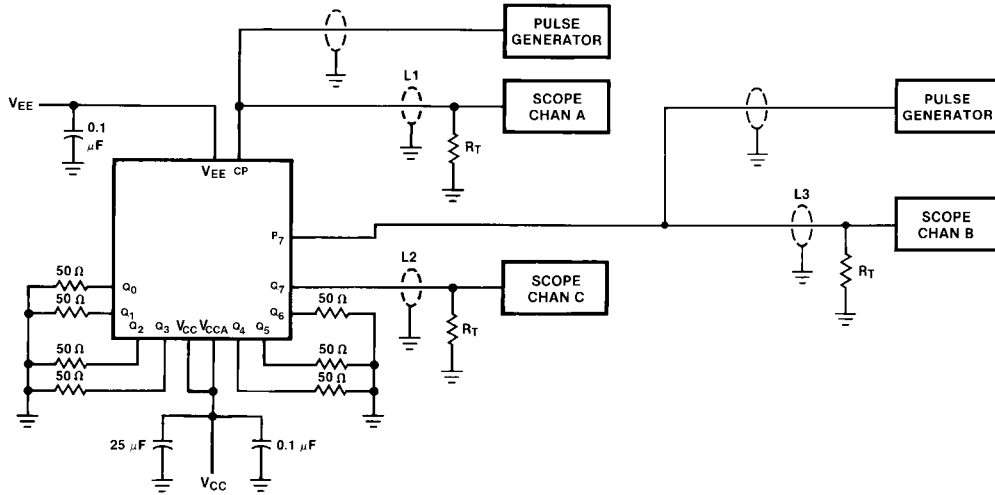

**Note:**

- $V_{CC}, V_{CCA} = +2V, V_{EE} = -2.5V$
- L1, L2 and L3 = equal length 50Ω impedance lines
- $R_T = 50\Omega$  terminator internal to scope
- Decoupling 0.1 μF from GND to  $V_{CC}$  and  $V_{EE}$
- All unused outputs are loaded with 50Ω to GND
- $C_L$  = Fixture and stray capacitance  $\leq 3$  pF

**FIGURE 1. AC Test Circuit**

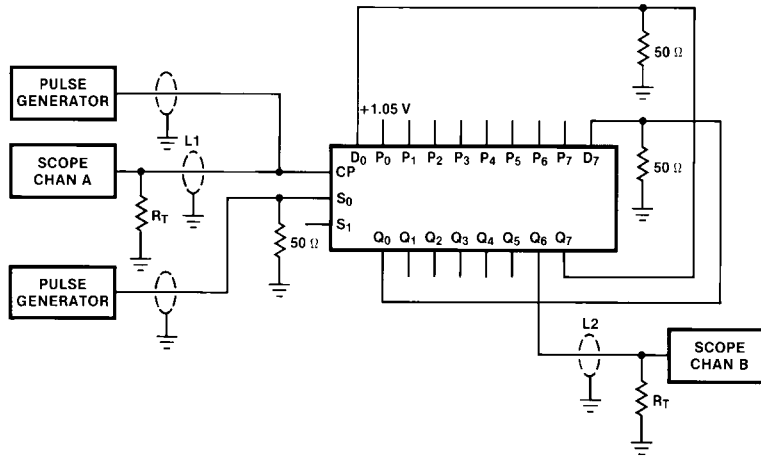

**Note:**

- For shift right mode pulse generator connected to  $S_0$  is moved to  $S_1$ .
- Pulse generator connected to  $S_1$  has a LOW frequency 99% duty cycle, which allows occasional parallel load.
- The feedback path from output to input should be as short as possible.

**FIGURE 2. Shift Frequency Test Circuit (Shift Left)**

### Switching Waveforms

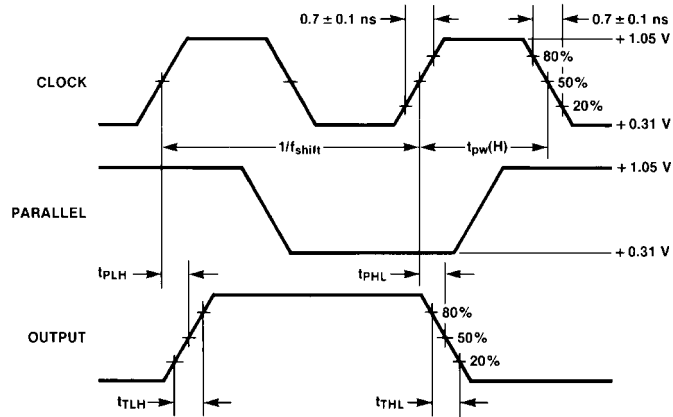
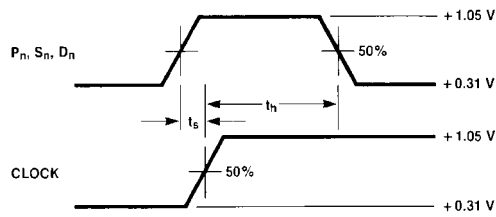

FIGURE 3. Propagation Delay and Transition Times



**Note:**

$t_s$  is the minimum time before the transition of the clock that information must be present at the data input.  
 $t_h$  is the minimum time after the transition of the clock that information must remain unchanged at the data input.

FIGURE 4. Setup and Hold Times

**Physical Dimensions** inches (millimeters) unless otherwise noted

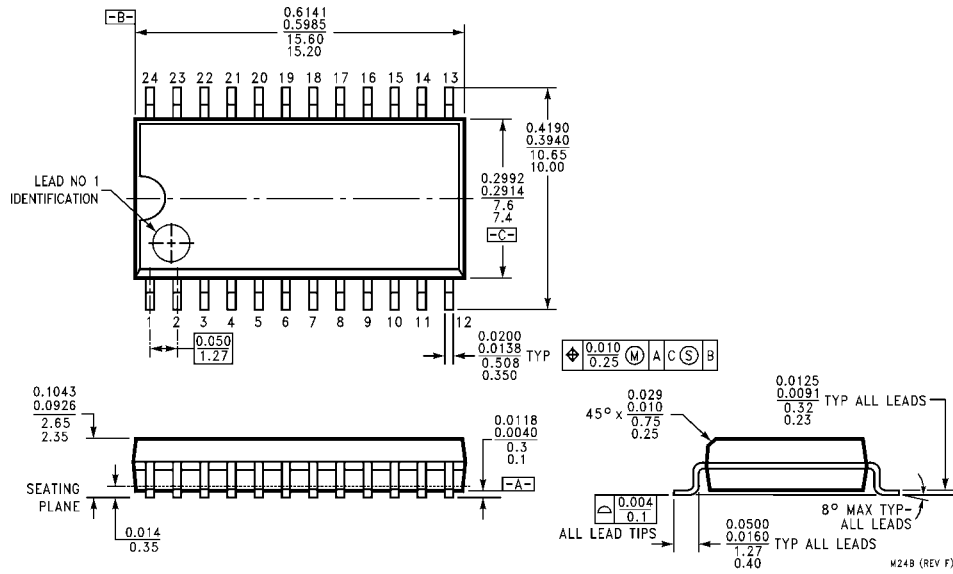

**24-Lead Small Outline Integrated Circuit (SOIC), JEDEC MS-013, 0.300 Wide Package Number M24B**

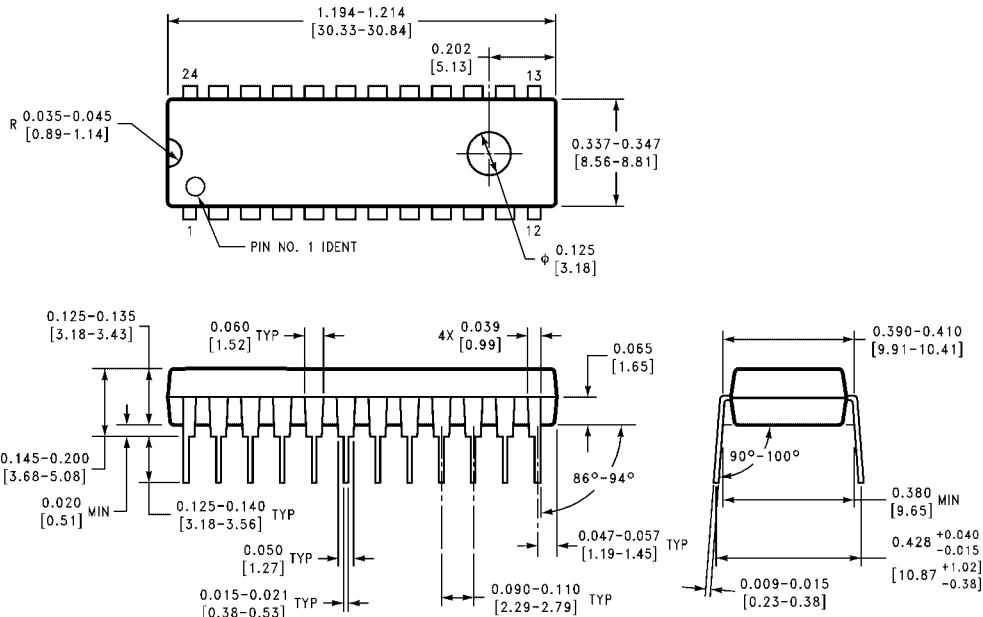

**24-Lead Plastic Dual-In-Line Package (PDIP), JEDEC MS-010, 0.400 Wide Package Number N24E**





LittleDiode supplies new, hard to find or obsolete electronic components and semiconductors all over the world.

With over two million different components listed you are sure to find the part you need.

Feel free to visit us today at our online store:

[LittleDiode.com](http://LittleDiode.com)

Looking forward to providing you with the best possible service.