

Thyratrons



Description

Thyratrons are fast acting high voltage switches suitable for a variety of applications including radar, laser and scientific use.

PerkinElmer's thyratrons are constructed of ceramic and metal for strength and long life. Over 300 thyratron types are available from PerkinElmer. The types listed in this guide are a cross section of the broad line available. We encourage inquiries for thyratrons to suit your particular application.

Features

- Wide operating voltage range
- High pulse rate capability
- Ceramic-metal construction
- High current capability
- Long life

How a Thyatron works

The operation of the device can be divided into three phases: triggering and commutation (closure), steady-state conduction, and recovery (opening), each of which is discussed below.

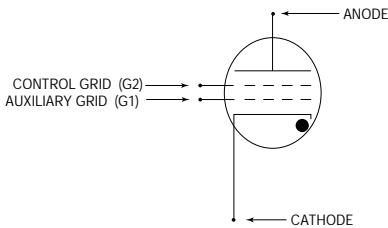

Figure 1. Thyatron with auxiliary grid (heater detail not shown)

Triggering and Commutation

When a suitable positive triggering pulse of energy is applied to the grid, a plasma forms in the grid-cathode region from electrons. This plasma passes through the apertures of the grid structure and causes electrical breakdown in the high-voltage region between the grid and the anode. This begins the process of thyatron switching (also called commutation). The plasma that is formed between the grid and the anode diffuses back through the grid into the grid-cathode space. "Connection" of the plasma in the anode-grid space with the plasma in the cathode-grid space completes the commutation process.

The commutation process is simply modeled as shown in Figure 2.

The time interval between trigger breakdown of the grid-cathode region and complete closure of the thyatron is called the anode delay time. It is typically 100-200 nanoseconds for most tube types.

During commutation, a high voltage spike appears at the grid of the thyatron. This spike happens in the time it takes for the plasma in the grid-anode space to "connect" to the plasma in the grid-cathode space. During this time, the anode is momentarily "connected" to the grid thereby causing the grid to assume a voltage nearly that of the anode's.

Although the grid spike voltage is brief in duration, usually less than

100 nS, it can damage the grid driver circuit unless measures are taken to suppress the spike before it enters the grid driver circuit. The location of the grid spike suppression circuit is shown in Figure 3, Grid Circuit.

Figure 4, Typical Grid Spike Suppression Circuits, shows the more common methods used to protect the grid driver circuit. In using any of these types of circuits, care must be exercised to assure that the Grid Driver Circuit pulse is not attenuated in an unacceptable manner. The values for the circuit components are dependent on the characteristics of the thyatron being driven, the

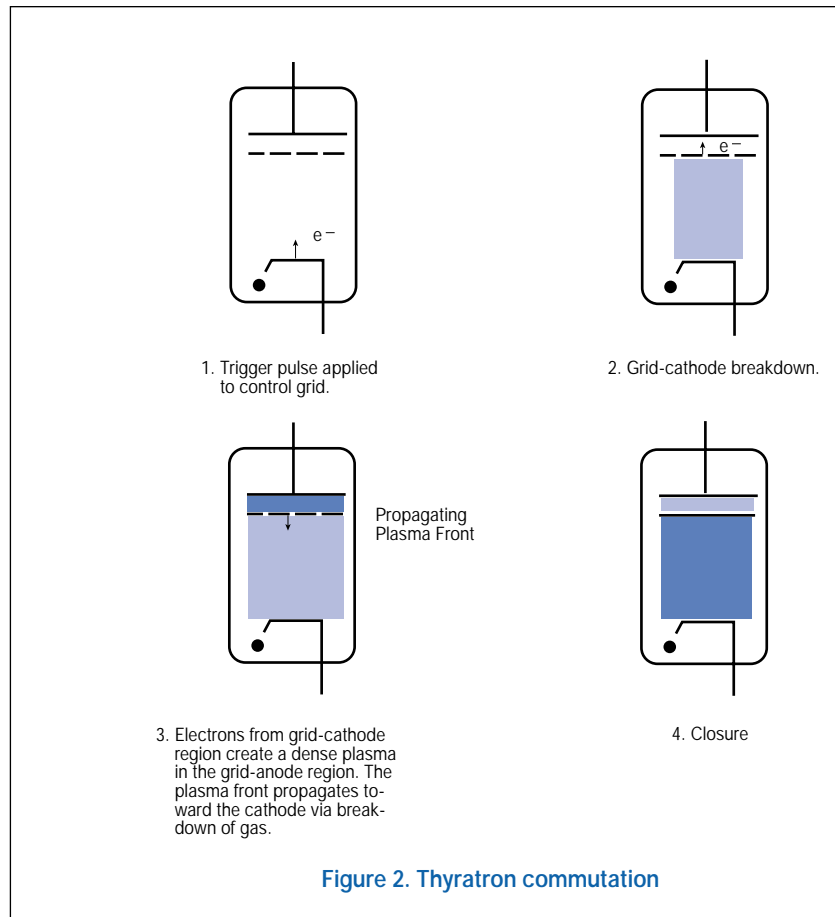

Figure 2. Thyatron commutation

grid driver circuit design, and the performance required from the thyatron itself. Contact the applications engineering department at PerkinElmer to discuss the specific details of your requirement.

Conduction

Once the commutation interval has ended, a typical hydrogen thyatron will conduct with nearly constant voltage drop on the order of 100 volts regardless of the current through the tube.

Recovery

Thyatrions open (recover) via diffusion of ions to the tube inner walls and electrode surfaces, where the ions can recombine with electrons. This process takes from 30 to 150 microseconds, depending on the tube type, fill pressure, and gas (hydrogen or deuterium). The theoretical maximum pulse repetition rate is the inverse of the recovery time.

Recovery can be promoted by arranging to have a small negative DC bias voltage on the control grid when forward conduction has ceased. A bias voltage of 50 to 100 volts is usually sufficient.

Recovery can also be improved by arranging to have small negative voltage on the anode after forward conduction has ceased. In many radar circuits, a few-percent negative mismatch between a pulse-forming network and the load ensures a residual negative anode voltage. In laser circuits, classical pulse-forming networks are seldom used, so inverse anode voltage may not be easily generated. Recovery then strongly depends on the characteristics of the anode charging circuit. In general, charging schemes

involving gently rising voltages (i.e., resonant charging and ramp charging) favor thyatron recovery, and therefore allow higher pulse repetition rates. Fast ramping and resistive charging put large voltages on the anode quickly, thus making recovery more difficult. The ideal charging scheme from the viewpoint of thyatron recovery is command charging, wherein voltage is applied to the thyatron only an instant before firing.

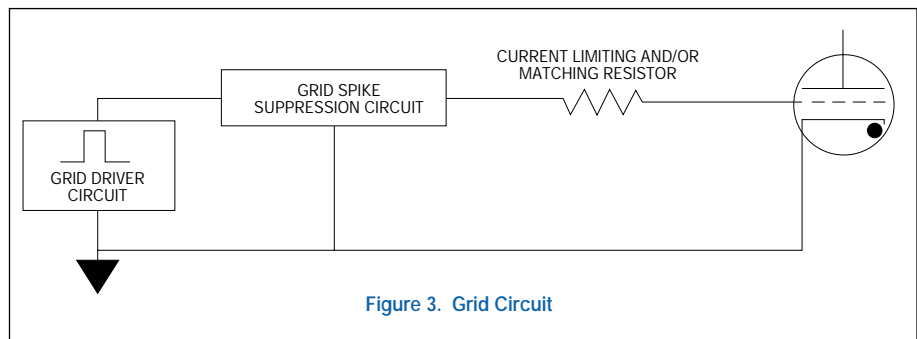

Figure 3. Grid Circuit

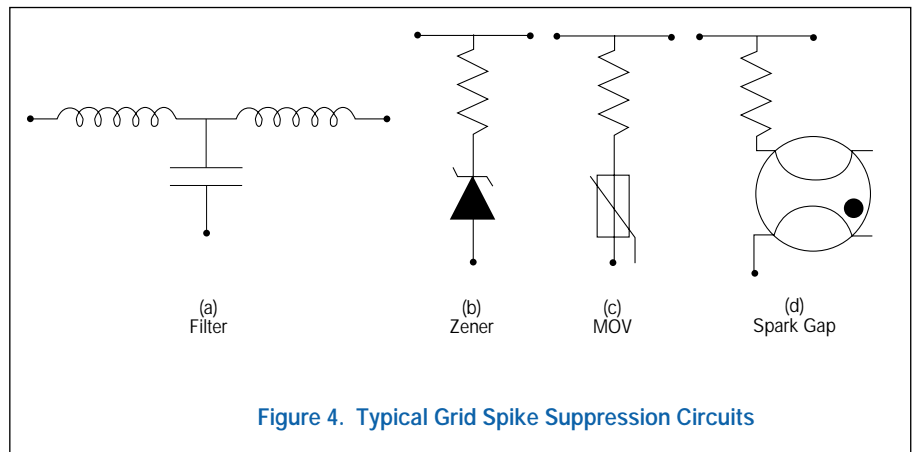

Figure 4. Typical Grid Spike Suppression Circuits

Thyratrons

Type	Peak Anode Voltage (kV)	Peak Anode Current (a)	Average Anode Current (Adc)	RMS Anode Current (Aac)	Plate Dissipation Factor Pb (x 10 ⁹)	Cathode Heater V/A	Reservoir Heater V/A	Peak Forward Grid Voltage (Min)	Impedance of Grid Circuits (Max)	EIA Type & Comments	Notes	Seated Height x Tube Width (Inches)
HY-2	8	100	0.1	2	2.7	6.3/3.5	Note 1	175	1200	JAN 7621	1	2.35 x 1.0
HY-6	16	350	0.5	6.5	5	6.3/7	6.3/2.5	150	1500	JAN 7782		2 x 1.4
HY-60	16	350	0.5	6.5	5	6.3/7	6.3/7	150	1500	JAN 7665A		2.4 x 1.4
HY-61	16	350	0.5	6.5	5	6.3/8.5	Note 1	150	1500		1	3.6 x 1.4
HY-10	20	500	0.5	8	10	6.3/7.5	6.3/4	200	500	JAN 7620		3.4 x 2
HY-11	18	1600	0.5	8	10	6.3/7.5	6.3/4	200	500			2.2 x 2.25
HY-1A	18	500	0.5	8	10	6.3/11	Note 1	175	500	JAN8613	1	5 x 2
HY-1102	18	1000	0.5	16	10	6.3/7.5	6.3/8	20	500		2	2 x 2
HY-3192	32	1000	2.2	47.5	50	6.3/12.5	6.3/5.5	1500	250		3	3.75 x 3.25
HY-32	32	1500	2.2	47.5	50	6.3/18	6.3/5.5	450	400		4	4 x 3.25
HY-3204	32	1500	1	25	40	6.3/18	6.3/6	450	400	ib to 10kA @ <1usec	4	3 x 6
1802	25	5000	2.2	47.5	50	6.3/12.5	6.3/5.5	500	400	JAN 7322	4	4 x 3.25
HY-3002	25	5000	2.2	47.5	50	6.3/12.5	6.3/5.5	500	400			4 x 3.25
HY-3003	35	5000	2.2	47.5	50	6.3/12.5	6.3/5.5	500	400			4 x 3.25
HY-3004	25	5000	2.2	47.5	50	6.3/12.5	6.3/5.5	500	400			4.75 x 3.25
HY-3005	35	5000	2.2	47.5	50	6.3/12.5	6.3/5.5	500	400		3	4.75 x 3.25
HY-3025	28	5000	2.2	47.5	50	6.3/12.5	6.3/5.5	500	250			4.25 x 3.25
HY-3189	32	5000	2.2	47.5	50	6.3/12.5	6.3/5.5	500	250			3.75 x 3
HY-5	40	5000	8	125	160	6.3/30	4.5/11	1300	100	8614		5 x 4.5
HY-53	40	5000	4	90	100	6.3/30	4.5/11	1300	100		3	5 x 4.5
LS-3101S	35	5000	2	45	50	6.3/18	6.3/6	500	250		6	5.25 x 3
LS-4101	40	12000	3	55	50	6.3/28	6.3/6	500	250		3,6	8 x 3.5
LS-4111	40	12000	3	55	100	6.3/28	6.3/6	500	250		3,5,6	8.25 x 3.5
HY-3246	45	15000	2	45	50	6.3/16	6.3/6	500	250	Two gap tetrode		5.75 x 3
LS-3229	70	15000	2	45	50	6.3/16	6.3/6	450	400		3,6	6.4 x 3
HY-3202	32	20000	0.5	47.5	50	6.3/18	6.3/13	500	250		2,6	6.4 x 3
LS-5001	40	20000	4	90	100	6.3/29	4.5/10	2500	50		3	6.75 x 4.5
LS-5002	50	20000	4	70	100	6.3/35	4.5/15	2500	100	Two gap tetrode	3	9.5 x 4.5
LS-5101	40	20000	4	90	100	6.3/29	4.5/10	2500	50		3,6	6.75 x 4.5
LS-5111	40	20000	4	90	200	6.3/29	4.5/10	2500	50		3,5,6	7.2 x 4.5

Notes

1. Cathode and reservoir heater internally connected
2. Grounded grid design
3. Auxiliary grid design
4. MT-4 mount required
5. Liquid cooling design
6. Hollow anode design for reverse current

PerkinElmer thyratron control grid driver TM-27 recommended for use with all thyratrons up to 3 inch diameter. TM-29 recommended for thyratrons greater than 3 inch diameter.

The selections above are a representative sample of hundreds of design variations available. Contact PerkinElmer for support for any specific application.

Definition of Terms

TERMS USED TO CHARACTERIZE INDIVIDUAL PULSES

Peak Anode Voltage (epy): maximum positive anode voltage, with respect to the cathode.

Peak Inverse Anode Voltage (epx): maximum negative anode voltage, with respect to the cathode.

Peak Forward Anode Current (ib): maximum instantaneous positive anode current.

Peak Inverse Current (l_{bx}): maximum instantaneous negative anode current.

Pulse Width (tp): current pulse full-width at half-maximum.

Pulse Repetition Rate (pr): average number of pulses/second.

Current Rise Time (tr): time for the forward current to rise from 10% to 90% of its peak value.

Anode Fall Time: time for the forward anode voltage to collapse from 90% to 10% of its maximum value.

Anode Delay Time (tad): time interval between triggering and commutation (commutation is defined below). The precise reference points for this interval vary with the application.

Anode Delay Time Drift (Δt_{ad}): gradual decrease in anode delay time that occurs as the thyatron warms up.

Jitter (tj): pulse-to-pulse variation in anode delay time.

TIME AVERAGED QUANTITIES

DC Average Current (I_b): forward current averaged over one second.

RMS Average Current (I_p): root-mean-square current averaged over one second.

Plate Breakdown Factor (P_b): numerical factor proportional to the power dissipated at the anode, averaged over one second. $P_b = epy \times ib \times pr$.

STRUCTURAL PARTS OF THE THYRATRON

Auxiliary Grid: grid placed between the control grid and cathode in some thyratrons. A small DC current (or a larger pulsed current) applied between Auxiliary Grid and cathode can be used to control the anode delay time. (Anode delay time is defined above). Thyratrons with auxiliary grids are called Tetrode Thyratrons.

Reservoir: maintains the gas pressure in the tube at a level which depends on the reservoir heater voltage.

GENERAL TERMINOLOGY

Static (Self) Breakdown Voltage (SBV): applied voltage at which a thyatron will break down spontaneously, without being triggered.

Commutation: transition from trigger breakdown to full closure of the thyatron.

Recovery Time: time which must elapse after decay of the circuit current before anode voltage can be reapplied to the thyatron without causing self-breakdown. The maximum possible pulse repetition rate is the inverse of the recovery time.

Grid Bias: negative DC voltage which may be applied to the control grid to speed up recovery.

Marking

PerkinElmer's trademark, part designation, and date code.

PerkinElmer welcomes inquiries about special types. We would be pleased to discuss the requirements of your application and the feasibility of designing a type specifically suited to your needs.

For more information email us at opto@perkinelmer.com or visit our web site at www.perkinelmer.com/opto

Note: All specifications subject to change without notice.

USA:

PerkinElmer Optoelectronics
35 Congress Street
Salem, MA 01970
Toll Free: (800) 950-3441 (USA)
Phone: (978) 745-3200
Fax: (978) 745-0894





LittleDiode supplies new, hard to find or obsolete electronic components and semiconductors all over the world.

With over two million different components listed you are sure to find the part you need.

Feel free to visit us today at our online store:

LittleDiode.com

Looking forward to providing you with the best possible service.