

$I_{F(AV)} = 19\text{Amp}$ $V_R = 15\text{V}$
--

Major Ratings and Characteristics

Characteristics	19TQ015	Units
$I_{F(AV)}$ Rectangular waveform	19	A
V_{RRM}	15	V
I_{FSM} @tp = 5 μ s sine	700	A
V_F @19Apk, $T_J = 75^\circ\text{C}$	0.32	V
T_J range	-55 to 125	$^\circ\text{C}$

Description/Features

The 19TQ015 Schottky rectifier has been optimized for ultra low forward voltage drop specifically for the OR-ing of parallel power supplies. The proprietary barrier technology allows for reliable operation up to 125 $^\circ$ C junction temperature. Typical applications are in parallel switching power supplies, converters, reverse battery protection, and redundant power subsystems.

- 125 $^\circ\text{C}$ T_J operation ($V_R < 5\text{V}$)
- Optimized for OR-ing applications
- Ultra low forward voltage drop
- High frequency operation
- Guard ring for enhanced ruggedness and long term reliability
- High purity, high temperature epoxy encapsulation for enhanced mechanical strength and moisture resistance

Case Styles

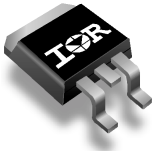
<p>19TQ015</p>  <p>TO-220</p>	<p>19TQ015S</p>  <p>D²PAK</p>
--	--

Voltage Ratings

Part number	19TQ015
V_R Max. DC Reverse Voltage (V)	15
V_{RMM} Max. Working Peak Reverse Voltage (V)	

Absolute Maximum Ratings

Parameters	19TQ	Units	Conditions
$I_{F(AV)}$ Max. Average Forward Current * See Fig. 5	19	A	50% duty cycle @ $T_C = 80^\circ\text{C}$, rectangular wave form
I_{FSM} Max. Peak One Cycle Non-Repetitive Surge Current * See Fig. 7	700	A	5 μs Sine or 3 μs Rect. pulse
	330		10ms Sine or 6ms Rect. pulse
E_{AS} Non-Repetitive Avalanche Energy	6.75	mJ	$T_J = 25^\circ\text{C}$, $I_{AS} = 1.50$ Amps, $L = 6$ mH
I_{AR} Repetitive Avalanche Current	1.50	A	Current decaying linearly to zero in 1 μsec Frequency limited by T_J max. $V_A = 3 \times V_R$ typical

Electrical Specifications

Parameters	19TQ	Units	Conditions
V_{FM} Max. Forward Voltage Drop (1) * See Fig. 1	0.36	V	@ 19A
	0.46	V	@ 38A
	0.32	V	@ 19A
	0.43	V	@ 38A
I_{RM} Max. Reverse Leakage Current (1) * See Fig. 2	10.5	mA	$T_J = 25^\circ\text{C}$
	522	mA	$T_J = 100^\circ\text{C}$
	465	mA	$T_J = 100^\circ\text{C}$, $V_R = 12\text{V}$
	285	mA	$T_J = 100^\circ\text{C}$, $V_R = 5\text{V}$
C_T Max. Junction Capacitance	2000	pF	$V_R = 5V_{DC}$, (test signal range 100Khz to 1Mhz) 25°C
L_S Typical Series Inductance	8.0	nH	Measured lead to lead 5mm from package body
dv/dt Max. Voltage Rate of Change (Rated V_R)	10,000	V/ μs	

(1) Pulse Width < 300 μs , Duty Cycle < 2%

Thermal-Mechanical Specifications

Parameters	19TQ	Units	Conditions
T_J Max. Junction Temperature Range	-55 to 125	$^\circ\text{C}$	
T_{stg} Max. Storage Temperature Range	-55 to 150	$^\circ\text{C}$	
R_{thJC} Max. Thermal Resistance Junction to Case	1.50	$^\circ\text{C}/\text{W}$	DC operation * See Fig. 4
R_{thCS} Typical Thermal Resistance, Case to Heatsink	0.50	$^\circ\text{C}/\text{W}$	Mounting surface, smooth and greased
wt Approximate Weight	2(0.07)	g(oz.)	
T Mounting Torque	Min.	6(5)	Kg-cm (lbf-in)
	Max.	12(10)	

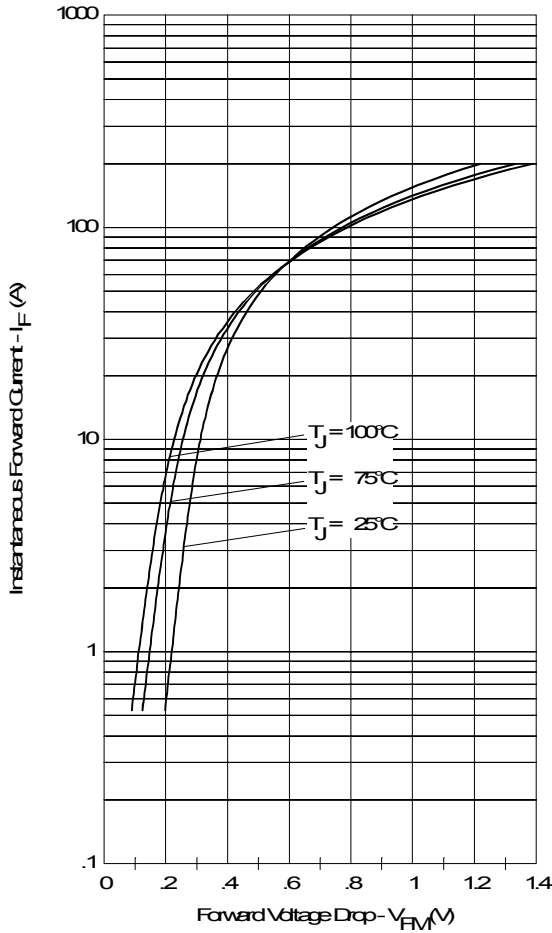

Fig. 1 - Maximum Forward Voltage Drop Characteristics

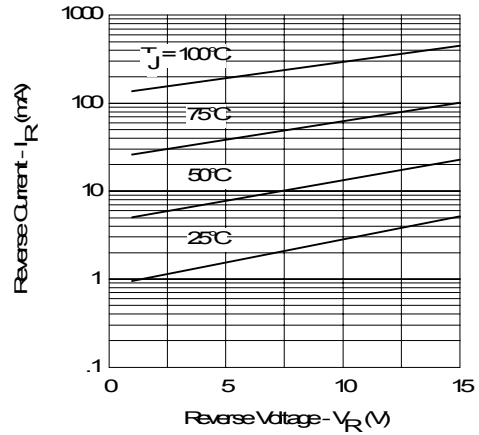

Fig. 2 - Typical Values of Reverse Current Vs. Reverse Voltage

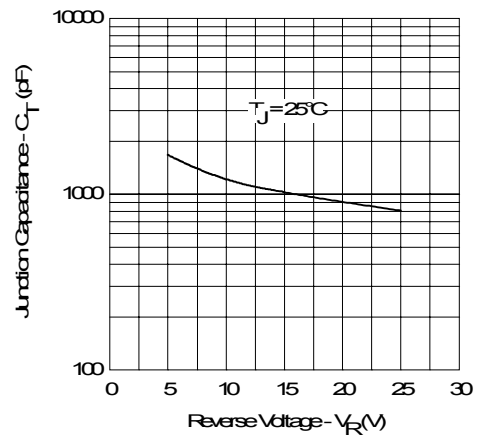

Fig. 3 - Typical Junction Capacitance Vs. Reverse Voltage

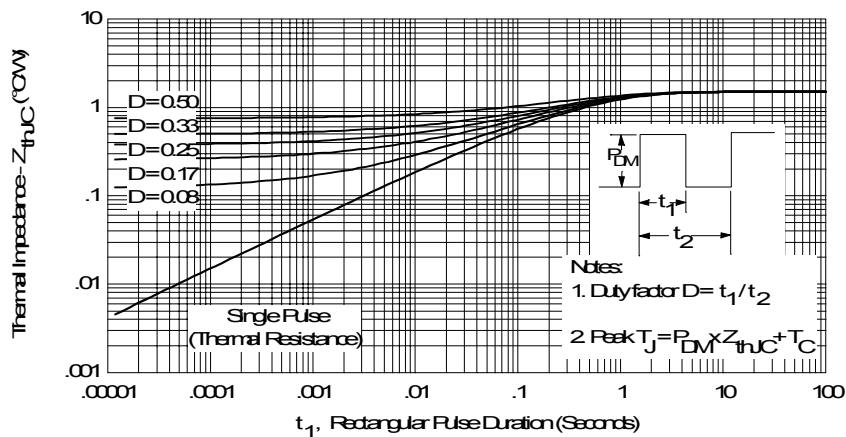

Fig. 4 - Maximum Thermal Impedance Z_{thJC} Characteristics

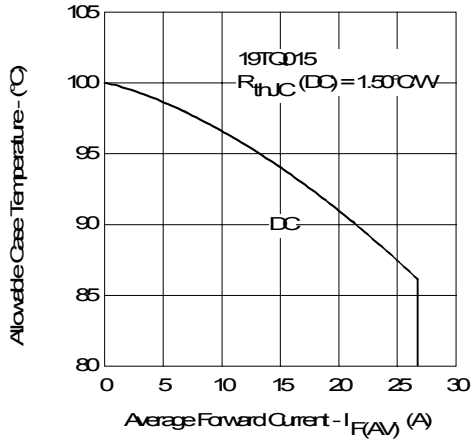

Fig. 5- Maximum Allowable Case Temperature Vs. Average Forward Current

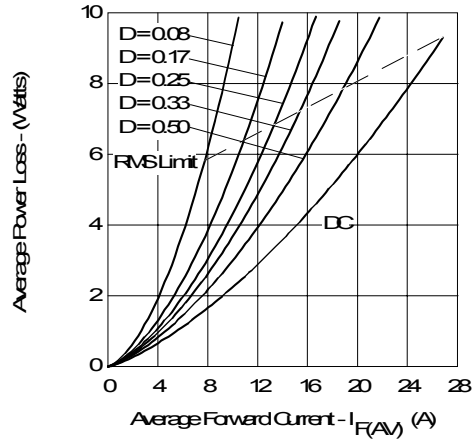

Fig. 6- Forward Power Loss Characteristics

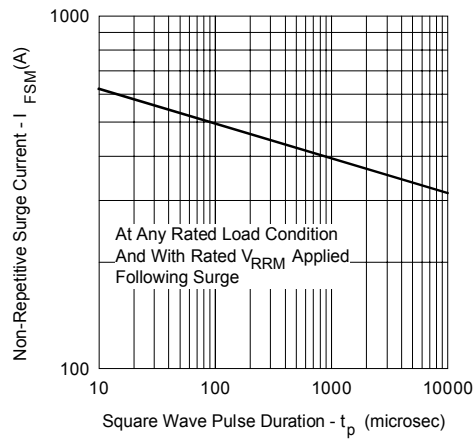

Fig. 7- Maximum Non-Repetitive Surge Current

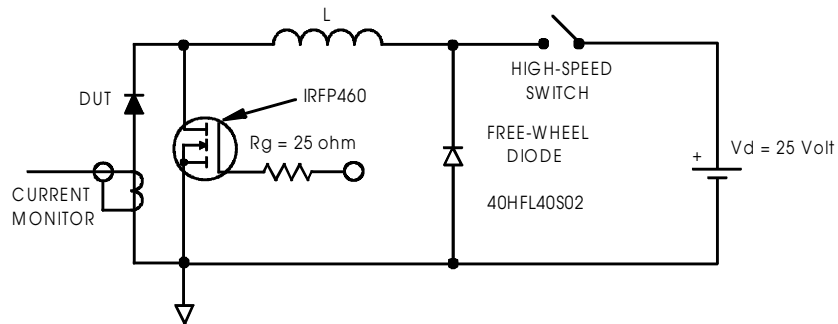
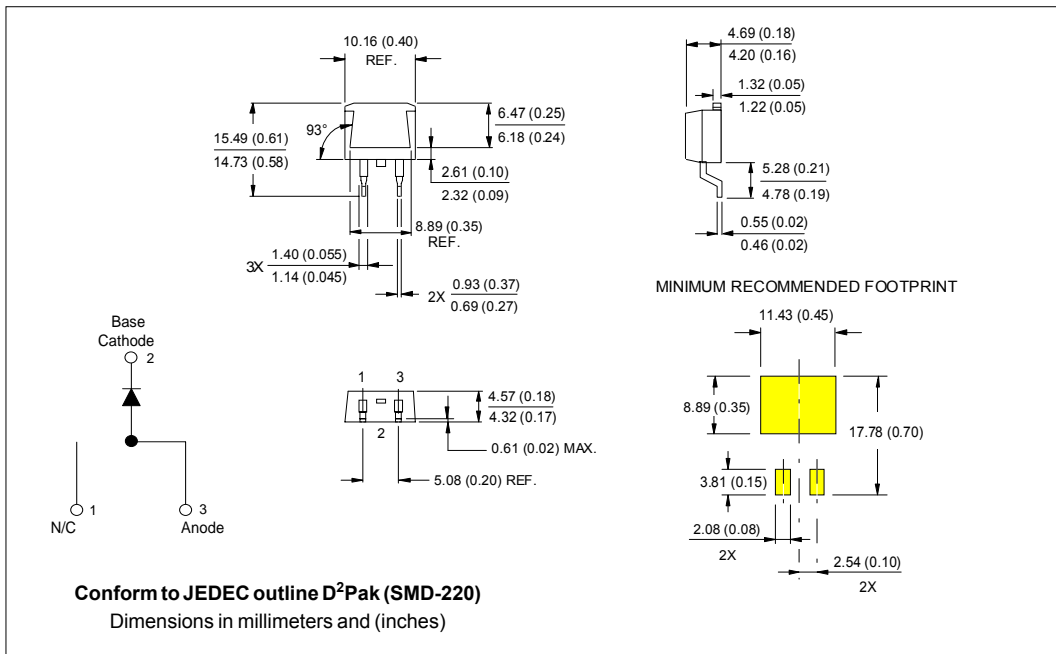
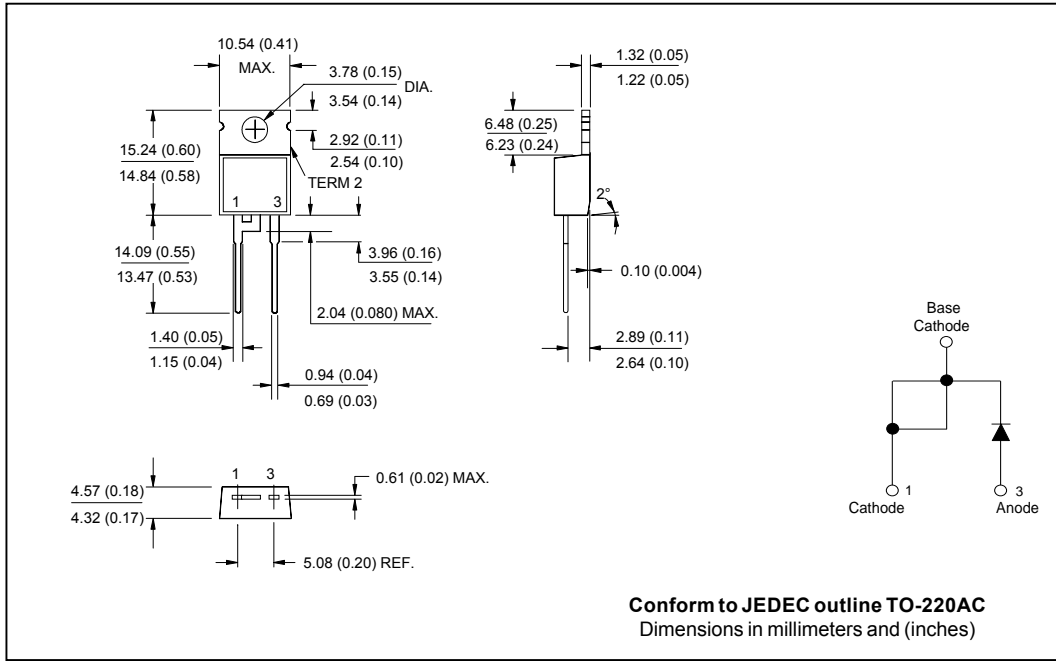
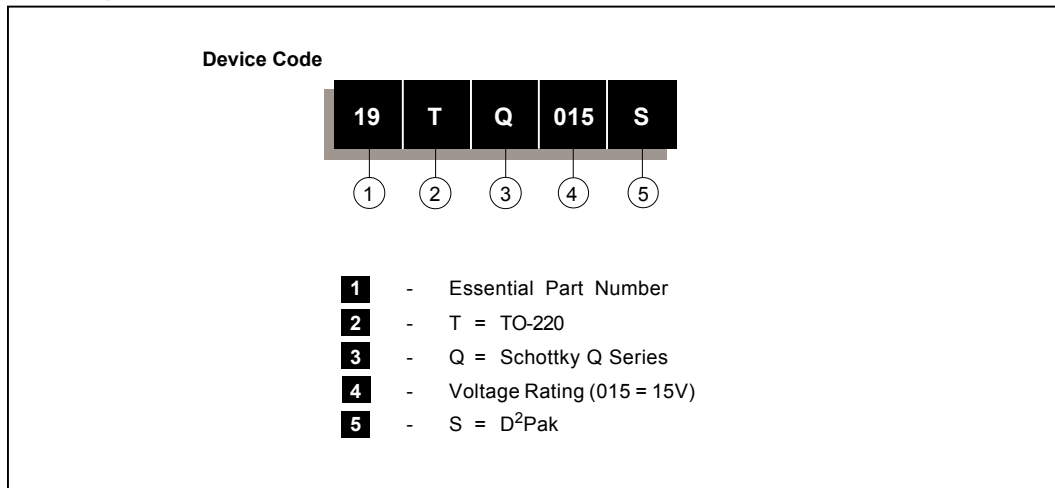

Fig. 8- Unclamped Inductive Test Circuit

Outline Table



Ordering Information Table





LittleDiode supplies new, hard to find or obsolete electronic components and semiconductors all over the world.

With over two million different components listed you are sure to find the part you need.

Feel free to visit us today at our online store:

LittleDiode.com

Looking forward to providing you with the best possible service.