

SILICON MIXER DIODE

DESCRIPTION:

The **ASI 1N415E** is a Silicon Mixer Diode Designed for Applications Operating From 8.0 to 12.4 GHz.

FEATURES:

- High burnout resistance
- Low noise figure
- Hermetically sealed package

MAXIMUM RATINGS

I_F	20 mA
V_R	1.0 V
P_{DISS}	2.0 (ERGS) @ T _C = 25 °C
T_J	-55 °C to +150 °C
T_{STG}	-55 °C to +150 °C

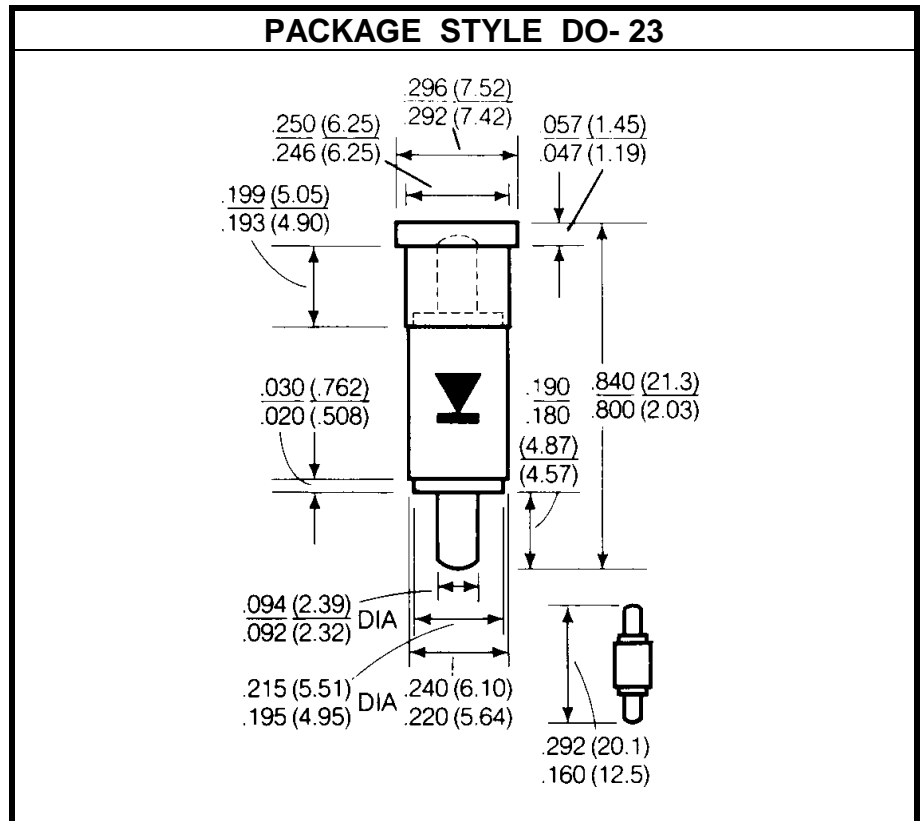
CHARACTERISTICS T_C = 25 °C

SYMBOL	TEST CONDITIONS	MINIMUM	TYPICAL	MAXIM	UNITS
N_F	F = 9375 MHz R _L = 100 Ω P _{io} = 1.0 mW I _F = 30 MHz N _{Fif} = 1.5 dB			7.5	dB
V_{SWR}				1.3	
Z_{IF}	R _L = 22 Ω f = 1000 Hz	335		465	Ω
frange		8.0		12.4	GHz

This datasheet has been downloaded from:

www.DatasheetCatalog.com

Datasheets for electronic components.



LittleDiode supplies new, hard to find or obsolete electronic components and semiconductors all over the world.

With over two million different components listed you are sure to find the part you need.

Feel free to visit us today at our online store:

LittleDiode.com

Looking forward to providing you with the best possible service.