

## Implementing Constant Current Constant Voltage AC Adapter by NCP1200 and NCP4300A

Prepared by: Hector Ng  
ON Semiconductor



ON Semiconductor™

<http://onsemi.com>

---

### APPLICATION NOTE

#### Introduction

This paper describes a compact design of constant current constant voltage (CCCV) AC adapter based on the current mode PWM controller NCP1200 and the secondary side feedback IC NCP4300A. By these two ICs from ON Semiconductor, circuit design is much simplified. These devices enable users to meet ever increasing demand of smaller dimension and more sophisticated protection feature of AC adapter.

On the primary side, NCP1200 is used as the PWM controller. This current mode controller requires very few external components and no auxiliary winding is needed to supply this IC. In addition, NCP1200 can fulfill IEA recommendation easily because it features a pulse skipping low power consumption mode.

NCP4300A is a general purpose device which consists of two operational amplifiers and a high precision voltage reference. One of the operational amplifiers is capable of rail to rail operation. NCP4300A is employed to provide voltage as well as current feedback to NCP1200.

Output of the AC adapter is maintained at 5.2 V from no load to 600 mA. Further increase in load enters constant current output portion and output is kept at 600 mA down to zero volt. This output characteristic assures a basic protection against battery overcharge which is needed by a lot of applications, for instance cellular phone AC adapter.

#### Circuit Description

Circuit and BOM of the AC adapter is shown in Figure 1 and Table 1. This design can accept universal AC input from 90 V to 264 VAC. Bulk capacitors C5 and C6 are split by inductor L1 and L2 to form the EMI filter as well as to provide energy storage for the remaining DC to DC converter circuit. Thanks to dynamic self supply of NCP1200 (please refer to NCP1200 data sheet), Vcc capacitor C7 is charged to startup voltage 11.4 V and the power MOSFET MTD1N60E starts switching. To reduce power consumption of NCP1200, HV pin (pin 8) is supplied by half wave rectification through a parallel combination of diode D6 and resistor R13. A small signal diode 1N4148 is enough for this function because diode D6 just has to withstand one diode drop during negative half cycle. R13 is to equilibrate the voltages on the 1N4148 when both diodes and high volt current source of NCP1200 are in the off state. R12 is to set the power level at which NCP1200 goes into pulse skipping, please refer to below section for more details. RCD snubber R1, C1 and D3 provides the necessary snubbing function to prevent drain voltage of MTD1N60E to exceed 600 V. Choosing suitable value for the sensing resistor R7 is very important as it limits the primary peak current during power up. If its value is too low, the system cannot deliver enough power during full load low AC input. On the contrary, the transformer may go into saturation and damages Q1 and NCP1200. Information on how to determine value of R7 is elaborated in latter paragraph.

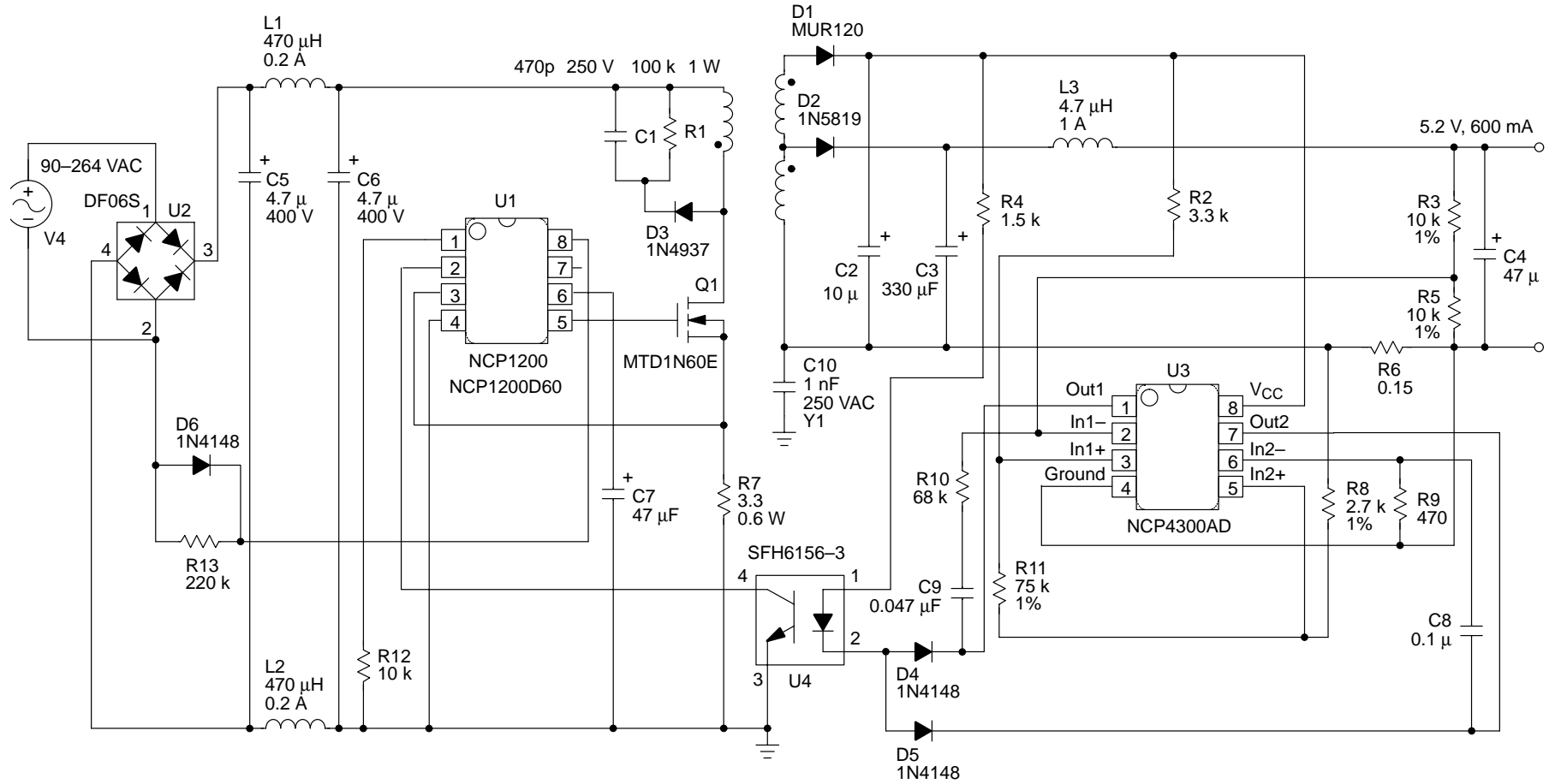

Figure 1. Circuit Description

# AND8042/D

Table 1.

| Reference  | Part                    | Quantity | Manufacturer                              |
|------------|-------------------------|----------|---|
| U1         | NCP1200D60              | 1        | ON Semiconductor                          |
| U2         | DF06S                   | 1        | General Semi or IR                        |
| U3         | NCP4300AD               | 1        | ON Semiconductor                          |
| U4         | SFH6156-3               | 1        | Infineon                                  |
| Q1         | MTD1N60E                | 1        | ON Semiconductor                          |
| C1         | 470 p, 250 V            | 1        |   |
| C2, C7     | 10 $\mu$ F, 25 V        | 2        |   |
| C3         | 330 $\mu$ F, 35 V       | 1        | Panasonic FC Series or Rubycon JXA Series |
| C4         | 47 $\mu$ F, 16 V        | 1        | Panasonic FC Series or Rubycon JXA Series |
| C5, C6     | 4.7 $\mu$ F, 400 V      | 2        |   |
| C8         | 0.1 $\mu$ F             | 1        |   |
| C9         | 0.047 $\mu$ F           | 1        |   |
| R1         | 100 K $\Omega$ , 1.0 W  | 1        |   |
| R2         | 3.3 K                   | 1        |   |
| R3, R5     | 10 K, 1%                | 2        |   |
| R4         | 1.5 K                   | 1        |   |
| R6         | 0.15 W, 0.1 W SMT       | 1        |   |
| R7         | 3.3 $\Omega$ , 0.6 W    | 1        |   |
| R8         | 2.7 K $\Omega$ , 1%     | 1        |   |
| R9         | 470 $\Omega$            | 1        |   |
| R10        | 68 K                    | 1        |   |
| R11        | 75 K $\Omega$ , 1%      | 1        |   |
| R12        | 10 K $\Omega$           | 1        |   |
| R13        | 220 K $\Omega$          | 1        |   |
| D1         | MUR120                  | 1        | ON Semiconductor                          |
| D4, D5, D6 | 1N4148                  | 3        |   |
| D2         | 1N5819                  | 1        | ON Semiconductor                          |
| D3         | 1N4937                  | 1        | ON Semiconductor                          |
| L1, L2     | 470 $\mu$ H, 0.2 A      | 2        |   |
| L3         | 4.7 $\mu$ H, 1.0 A      | 1        |   |
| T1         | Transformer             | 1        |   |
| C10        | 1.0 nF, 250 VAC, Y1 Cap | 1        |   |

The secondary side of the transformer consists of 2 windings, the output winding as well as a higher voltage winding which is used to supply power to NCP4300A. As the output may drop to 0 V during constant current operation, turn ratio of this higher voltage winding must be able to sustain minimum Vcc as specify by NCP4300A. Or else, the system will be lost of feedback and the output is not under control anymore. Figure 2 shows the internal block of NCP4300A. A 2.6 V, 1.0% tolerance voltage reference is connected to the non-inverting terminal of OP1. Thus, OP1 gives voltage feedback when its inverting terminal is connected to the potential divider R3 and R5. Characteristic of the voltage reference is similar to industry standard TL431 and a bias current supplied by R2 is needed to guarantee proper operation. This 2.6 V is also divided down by R11 and R8 to provide reference for output current sensing. Voltage developed at the non-inverting terminal of OP2 is:

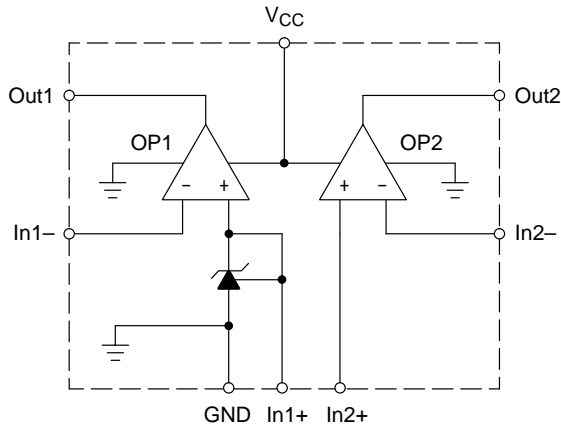

Figure 2.

$$V_{\text{current - reference}} = \left( \frac{2.7 \text{ K}}{2.7 \text{ K} + 75 \text{ K}} \right) \cdot 2.6 = 0.09 \text{ V}$$

Since Out1 and Out2 are wired together by diodes D4 and D5, feedback current through the opto-coupler U4 is dominated by whichever op-amp output that has a lower voltage. Thus feedback is dominated by OP1 until voltage developed across R6 reaches 0.09 V and this is equivalent to 600 mA passing through R6. Thanks to the rail to rail capability of OP2 in NCP4300A, current sensing function is guaranteed although voltage of non-inverting terminal of

OP2 is below ground. Once the output current reaches 600 mA, feedback action is taken over by OP2 and one will see a drop in output voltage if load is further increase but output current remains constant. C9, R10 and C8, R9 provide necessary feedback compensation for voltage and current loop respectively.

**Transformer Design**

Transformer design involves very tedious calculation. An Excel spreadsheet has been specially designed for NCP1200 to facilitate user with a quick determination of transformer parameters. Table 2 and Table 3 display the results of the spreadsheet after keying in system parameters. Although recommended transformer primary inductance is 4.6 mH, 3.2 mH is chosen instead. A lower primary inductance enables us to have a lower flyback voltage added to the drain of the power MOSFET. This in turn allow us to use a less heavy snubber which implies less power dissipated on the snubber. Disadvantage of a lower primary inductance is the increase in MOSFET conduction loss because of higher primary peak current. However, output of this AC adapter is only 3.0 W and typical R<sub>DS(on)</sub> of MTD1N60E is merely 5.9 Ω. Increment in conduction loss is not significant in this case.

After the primary inductance is determined, we have to decide on the ferrite core. It can be seen from the Excel spreadsheet that E16/8/5 core is big enough for this transformer. Primary (N1) and secondary (N2) number of turns needed are 166 and 12 respectively. However, one more winding N3 is required to supply NCP4300A. It is critical that voltage output of N3 must be higher than minimum operating voltage of NCP4300A even when output has dropped to 0 V. Under this condition, output winding loop can be represented by Figure 3.

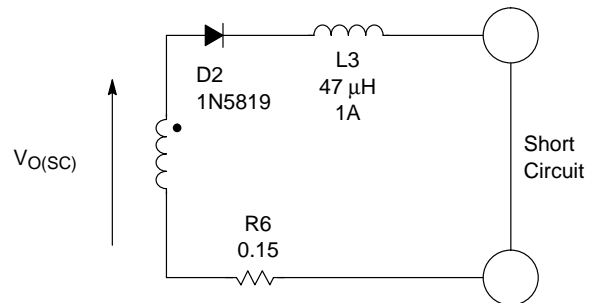

Figure 3.

# AND8042/D

Table 2.

| NCP1200 DISCONTINUOUS MODE DESIGN WORKSHEET |             |  |                        |
|---|-------------|--|------------------------|
| System Parameters                           |             |  |                        |
| $V_{max}$                                   | 264 V       | Maximum AC Input Voltage   | User Input Cells       |
| $V_{min}$                                   | 90 V        | Minimum AC Input Voltage   | Results                |
| $F_{line}$                                  | 50 Hz       | Line Frequency   |                        |
| $V_{min(DC)}$                               | 85.73 V     | Minimum DC Voltage   |                        |
| $F_{s(max)}$                                | 69 KHz      | Maximum Switching Frequency  |                        |
| $F_{s(typ)}$                                | 60 KHz      | Typical Switching Frequency  |                        |
| $F_{s(min)}$                                | 51 KHz      | Minimum Switching Frequency  |                        |
| $V_o$                                       | 5.2 V       | Output Voltage   | <b>Selected Device</b> |
| $I_o$                                       | 0.6 A       | Maximum Output Current   | 60 KHz                 |
| $\eta$                                      | 75%         | Efficiency   |                        |
| $V_{bd}$                                    | 600 V       | Power MOSFET Breakdown Voltage                                       |                        |
| $V_d$                                       | 1 V         | Output Diode Voltage Drop  |                        |
| $P_I$                                       | 4.16 W      | Input Power  |                        |
| $I_{in(pk)}$                                | 0.21 A      | Maximum Primary Peak Current   |                        |
| $V_{o'}$                                    | 85.72 V     | Reflected Output Voltage   |                        |
| $V_{pwr\_sw(max)}$                          | 459.07 V    | Maximum Voltage across the Power Switch Circuit (Less Leakage Spike) |                        |
| $D_{max}$                                   | 0.50        | Maximum Turn On Duty (Full Load, Low Line)                           |                        |
| $I_{in(av)}$                                | 0.05 A      | Maximum Input Average Current  |                        |
| Ratio N1/N2                                 | 13.83       | Turn Ratio Between Primary and Secondary                             |                        |
| Recommended $L_p$                           | 4.650 mH    | Recommended Primary Inductance                                       |                        |
| $L_p$                                       | 3.200 mH    | Primary Inductance   |                        |
| $R_{DS(ON)}$                                | 16 ohm      | Maximum $R_{DS(ON)}$ of Power MOSFET                                 |                        |
| $P_{dls(pwr\_sw)}$                          | 0.12 W      | Maximum Conduction Loss of Power MOSFET                              |                        |
| Input Filter Capacitor                      |             |  |                        |
| Recommended $C_{in}$                        | 14 $\mu$ F  | Recommended Input Filter Capacitance                                 |                        |
| $C_{in}$                                    | 9.4 $\mu$ F | Input Filter Capacitance   |                        |
| Output Diode Selection                      |             |  |                        |
| $I_o(pk)$                                   | 2.40 A      | Output Peak Current  |                        |
| $V_{ro}$                                    | 32.20 V     | Output Maximum Reverse Voltage                                       |                        |

# AND8042/D

Table 2. (continued)

| NCP1200 DISCONTINUOUS MODE DESIGN WORKSHEET            |                          |             |   |             |             |                 |   |
|--|--------------------------|-------------|---|-------------|-------------|-----------------|---|
| <b>Wire Selection</b>                                  |                          |             |   |             |             |                 |   |
| $I_{in(rms)}$  | 0.08 A                   |             | Maximum Input RMS Current   |             |             |                 |   |
| $I_{o(rms)}$   | 0.98 A                   |             | Maximum Output RMS Current  |             |             |                 |   |
| Lay_p  | 1                        |             | Layer of Primary Winding  |             |             |                 |   |
| Lay_s  | 1                        |             | Layer of Secondary Winding  |             |             |                 |   |
| Primary Wire Size                                      | AWG 35                   |             | Maximum Wire Size   |             |             |                 |   |
| Secondary Wire Size                                    | AWG 24                   |             | AWG 24  |             |             |                 |   |
| RMS Current Density                                    | 4.9 (A/mm <sup>2</sup> ) |             |   |             |             |                 |   |
| <b>Core Selection</b>                                  |                          |             |   |             |             |                 |   |
| Flux Density Safety Factor                             | 0.4                      |             |   |             |             |                 |   |
| Bobbin Usage Factor                                    | 0.4                      |             |   |             |             |                 |   |
| Core Type  | Core Type A              | Core Type B | Core Type C   | Core Type D | Core Type E |                 |   |
| Core Name  | E 16/8/5                 | EI28-Z      | E25/13/7  | E 30/15/7   | E32/16/9    |                 |   |
| $A_e$  | 20.1                     | 86          | 52.5  | 60          | 83          | mm <sup>2</sup> | Effective Area                          |
| $B_{sat}$  | 0.5                      | 0.5         | 0.5   | 0.5         | 0.5         | T               | Saturation Magnetic Flux Density        |
| $A_w$  | 22.3                     | 39.4        | 61  | 90          | 108         | mm <sup>2</sup> | Bobbin Winding Window Area              |
| $A_{bob}$  | 8.92                     | 15.76       | 24.4  | 36          | 43.2        | mm <sup>2</sup> | Usable Area of Bobbin for Winding       |
| Gap Length d   | 0.22                     | 0.05        | 0.08  | 0.07        | 0.05        | mm              |   |
| $N_1$  | 166                      | 39          | 63  | 56          | 40          |                 | Primary Number of Turns                 |
| $N_2$  | 12                       | 3           | 5   | 4           | 3           |                 | Secondary Number of Turns               |
| $A_p$  | 0.02                     | 0.02        | 0.02  | 0.02        | 0.02        | mm <sup>2</sup> | Area of Single Turn of Primary Wire     |
| Lay_p  | 1                        | 1           | 1   | 1           | 1           |                 | Layer of Primary Winding                |
| $A_{pri}$  | 3.98                     | 0.93        | 1.52  | 1.33        | 0.96        | mm <sup>2</sup> | Area of Primary Winding                 |
| $A_s$  | 0.26                     | 0.26        | 0.26  | 0.26        | 0.26        | mm <sup>2</sup> | Area of a Single Turn of Secondary Wire |
| Lay_s  | 1                        | 1           | 1   | 1           | 1           |                 | Layer of Secondary Winding              |
| $A_{sec}$  | 3.12                     | 0.73        | 1.19  | 1.04        | 0.75        | mm <sup>2</sup> | Area of Secondary Winding               |
| $A_{sum}$  | 7.09                     | 1.66        | 2.72  | 2.38        | 1.72        | mm <sup>2</sup> | Total Winding Area                      |
| Enough Space?  | OK                       | OK          | OK  | OK          | OK          |                 |   |
| <b>Maximum Peak Current (Sensing Resistor) Setting</b> |                          |             |   |             |             |                 |   |
| $DL_p$   | 10%                      |             | Tolerance of Primary Inductance   |             |             |                 |   |
| $L_{p(min)}$   | 2.880 mH                 |             | Lowest Primary Inductance   |             |             |                 |   |
| $L_{p(max)}$   | 3.520 mH                 |             | Highest Primary Inductance  |             |             |                 |   |
| $I_{p(worst)}$   | 0.24 A                   |             | Worst Case Maximum Primary Peak Current<br>(Lowest Switching Frequency and Lowest Primary Inductance) |             |             |                 |   |
| $R_{sense(max)}$                                       | 4.20 ohm                 |             | Maximum Allowable Sensing Resistance  |             |             |                 |   |
| $R_{sense}$  | 3.30 ohm                 |             | Sensing Resistance  |             |             |                 |   |
| $B_{init}$   | 0.32 T                   |             | Magnetic Flux Density During Startup  |             |             |                 |   |

Table 3.

| Transformer Specification  |             |             |                  |
|----------------------------|-------------|-------------|------------------|
| Primary Inductance         | $L_p$       | 3.200 mH    |                  |
| Core Type                  | =           | E 16/8/5    |                  |
| Primary Wire Size          | =           | AWG 35      |                  |
| Layer of Primary Winding   | =           | 1           | Select Core Type |
| Primary Number of Turns    | $N_1$       | 166         | Core Type A      |
| Secondary Wire Size        | =           | AWG 24      |                  |
| Layer of Secondary Winding | =           | 1           |                  |
| Secondary Number of Turns  | $N_2$       | 12          |                  |
| Gap Length                 | $d$         | 0.22 mm     |                  |
| Enough Space?              | =           | OK          |                  |
| Input Filter Capacitor     |             |             |                  |
| Input Filter Capacitance   | $C_{in}$    | 9.4 $\mu$ F |                  |
| Output Diode               |             |             |                  |
| Maximum Reverse Voltage    | $V_{ro}$    | 32.20 V     |                  |
| Sensing Resistor           |             |             |                  |
| Sensing Resistance         | $R_{sense}$ | 3.30 ohm    |                  |

During flyback cycle, voltage across the output winding  $V_{o(sc)}$  is:

$$V_{o(sc)} = V(D2) + V(L3) + V(R6) + V(\text{PCB trace})$$

$V(D2)$  = forward voltage drop of 1N5819  $\approx$  0.6 V

If resistance of L3 is 0.1  $\Omega$ ,  $V(L3) = 0.1 \Omega \times 0.6 \text{ A} = 0.06 \text{ V}$

$V(R6) = 0.15 \Omega \times 0.6 \text{ A} = 0.09 \text{ V}$

If resistance of PCB trace is 0.15  $\Omega$ ,  $V(\text{PCB trace}) = 0.15 \Omega \times 0.6 \text{ A} = 0.09 \text{ V}$

Therefore  $V_{o(sc)}$  is 0.84 V and volt/turn is  $0.84/12 = 0.07$ .

Minimum operating voltage of NCP4300A is 3.0 V. Its supply winding voltage has to be 0.6 V higher if we assume forward drop on MUR120 is 0.6 V. Minimum number of turns required for this winding is  $3.6/0.07 \approx 52$  turns. As can be seen from the schematic, these 52 turns can be added on top of the output winding. Therefore 40 turns is enough for N3. When output is 5.2 V, supply winding voltage of NCP4300A is approximately 24.5 V. Thanks to its wide operating voltage, 24.5 V is below maximum operating voltage of NC4300A (35 V). The final design of the transformer is shown in Figure 4.

Another important consideration is the value of sensing resistor R7. Value of R7 control maximum primary peak current by the following equation.

$$I_p(\text{max}) = \frac{1.0 \text{ V}}{R7}$$

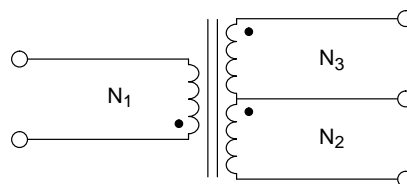

$N_1 = 166\text{T}$ , AWG # 34,  $\phi$  : 0.16 mm  
 $N_2 = 12\text{T}$ , AWG # 24,  $\phi$  : 0.51 mm  
 $N_3 = 40\text{T}$ , AWG # 34,  $\phi$  : 0.16 mm

Core = E16/8/5  
 Magnetic Material = PC40 or N67  
 Air Gap = 0.22 mm (center limb)  
 Primary Inductance (Across  $N_1$ ) = 3.2 mH

Figure 4.

For discontinuous mode operation, maximum power that can be delivered by the system is:

$$P_{\text{max}} = \frac{1}{2} L_p I_{pk}^2(\text{max}) f$$

Where  $L_p$  is the primary inductance which we already decided and  $f$  is the switching frequency. In other words,  $I_{pk}(\text{max})$  must be high enough to give full load power and this implies that R7 cannot be too high. The Excel spreadsheet has calculated for us that R7 must be lower than 4.2  $\Omega$ . 3.3  $\Omega$  is chosen to give some headroom during transient response. Before finalizing on this value, one must make

sure that transformer does not saturate at power up. During power up when output voltage is much lower than rated value, MTD1N60E is switched off not by PWM action. The power MOSFET is switched off because the primary peak current has reached its maximum allowable value,  $I_{p(max)}$ .  $I_{p(max)}$  drives the transformer core up the B–H curve of the magnetic material. B, magnetic flux density must be lower than the saturation value  $B_{sat}$ . For most magnetic material,  $B_{sat}$  equals 0.5 T at room temperature. Nevertheless,  $B_{sat}$  falls as temperature increases and at 120°C,  $B_{sat}$  becomes 0.35 T. Last row in Table 2 shows the magnetic flux density during startup. The value is 0.32 T, thus 3.3 Ω should give us a safe startup.

**Pulse Skipping Mode**

NCP1200 has a pulse skipping standby mode feature and the power level to enter standby mode is adjustable. Figure 5 shows the equivalent circuit of the Adj pin with a 10 K resistor connecting Adj pin to ground. When the voltage at FB pin falls below Adj pin, NCP1200 starts to skip cycle. This voltage  $V_{stby}$  is:

$$V_{stby} = \frac{10\text{ K}/29\text{ K}}{10\text{ K}/29\text{ K} + 75.5\text{ K}} \cdot 5.2\text{ V} = 0.466\text{ V}$$

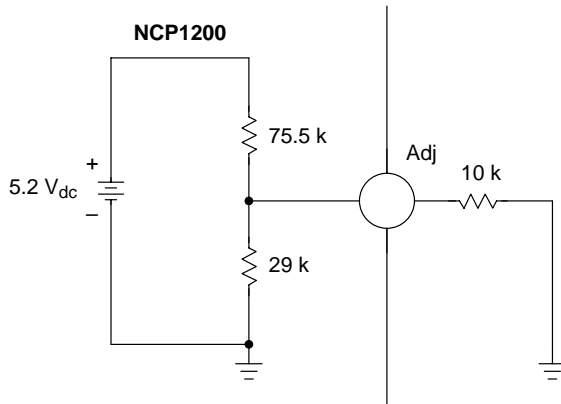

Figure 5.

Since NCP1200 is a current mode device, there is a direct relationship between voltage at the FB pin and the voltage developed by the peak current across the sensing resistor, ie. voltage at CS pin,  $V_{cs}$ . As can be seen from the block diagram of NCP1200 datasheet,  $V_{cs}$  is compared with one fourth of FB pin voltage. Therefore at the verge of entering into pulse skipping mode, we should see a relationship as shown on Figure 6.

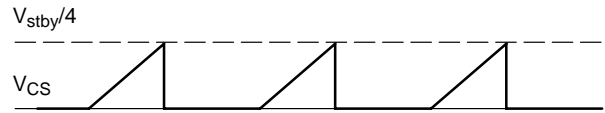

Figure 6.

Therefore the input power level  $P_{stby}$  that enters standby mode is given by the following equation.

$$\begin{aligned} P_{stby} &= \frac{1}{2} L_p \left( \frac{V_{stby}}{4R_7} \right)^2 f \\ &= 0.5 \times 3.2 \text{ E} - 3 \times \left( \frac{0.466}{4 \times 3.3} \right)^2 \times 60000 \\ &= 0.12\text{ W} \end{aligned}$$

At light load condition, efficiency should be lower than that of full load. Assume efficiency is 50% when input power is at 0.12 W, load current  $I_{o(stby)}$  at that time is:

$$I_{o(stby)} = \frac{0.12\text{ W} \times 50\%}{5.2\text{ V}} = 0.01\text{ A}$$

Remember that  $V_o$  drops when  $I_o$  attains 0.6 A. When  $V_o$  drops below certain voltage, NCP1200 will also enters pulse skipping mode. Once again, assume efficiency is 50% when input power is at 0.12 W,  $V_{o(stby)}$  at that time is:

$$V_{o(stby)} = \frac{0.12\text{ W} \times 50\%}{0.6\text{ A}} = 0.1\text{ V}$$

In summary, NCP1200 starts pulse skipping when  $I_o$  is below 0.01 A or  $V_o$  is below 0.1 V.

**Actual Performance**

Figure 7 and Table 4 shows the actual performance of the circuit.

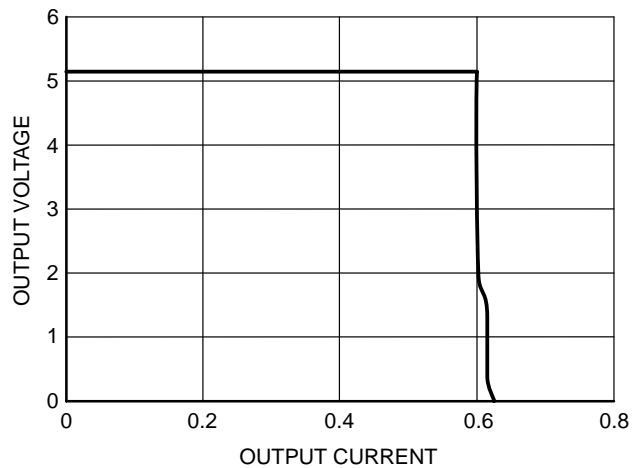

Figure 7.  $V_o$ – $I_o$  Characteristic @ 110 VAC Input

# AND8042/D

Table 4.

| Test            | Conditions   | Results  |
|-----------------|--|--|
| Line Regulation | $V_{in} = 90 \text{ to } 264 \text{ VAC}, I_o = 0.6 \text{ A}$   | $\Delta = 0.5 \text{ mV}$                              |
| Load Regulation | $V_{in} = 110 \text{ VAC}, I_o = 0 \text{ to } 0.6 \text{ A}$<br>$V_{in} = 220 \text{ VAC}, I_o = 0 \text{ to } 0.6 \text{ A}$               | $\Delta = 3.0 \text{ mV}$<br>$\Delta = 3.0 \text{ mV}$ |
| Output Ripple   | $V_{in} = 110 \text{ VAC}, I_o = 0.6 \text{ A}$<br>$V_{in} = 220 \text{ VAC}, I_o = 0.6 \text{ A}$   | 40 mVpp<br>40 mVpp                                     |
| Efficiency      | $V_{in} = 110 \text{ VAC}, V_o = 5.2 \text{ V}, I_o = 0.6 \text{ A}$<br>$V_{in} = 220 \text{ VAC}, V_o = 5.2 \text{ V}, I_o = 0.6 \text{ A}$ | 68%<br>61%   |

## Notes

## Notes

**ON Semiconductor** and  are trademarks of Semiconductor Components Industries, LLC (SCILLC). SCILLC reserves the right to make changes without further notice to any products herein. SCILLC makes no warranty, representation or guarantee regarding the suitability of its products for any particular purpose, nor does SCILLC assume any liability arising out of the application or use of any product or circuit, and specifically disclaims any and all liability, including without limitation special, consequential or incidental damages. "Typical" parameters which may be provided in SCILLC data sheets and/or specifications can and do vary in different applications and actual performance may vary over time. All operating parameters, including "Typicals" must be validated for each customer application by customer's technical experts. SCILLC does not convey any license under its patent rights nor the rights of others. SCILLC products are not designed, intended, or authorized for use as components in systems intended for surgical implant into the body, or other applications intended to support or sustain life, or for any other application in which the failure of the SCILLC product could create a situation where personal injury or death may occur. Should Buyer purchase or use SCILLC products for any such unintended or unauthorized application, Buyer shall indemnify and hold SCILLC and its officers, employees, subsidiaries, affiliates, and distributors harmless against all claims, costs, damages, and expenses, and reasonable attorney fees arising out of, directly or indirectly, any claim of personal injury or death associated with such unintended or unauthorized use, even if such claim alleges that SCILLC was negligent regarding the design or manufacture of the part. SCILLC is an Equal Opportunity/Affirmative Action Employer.

**PUBLICATION ORDERING INFORMATION**

**NORTH AMERICA Literature Fulfillment:**

Literature Distribution Center for ON Semiconductor  
 P.O. Box 5163, Denver, Colorado 80217 USA  
**Phone:** 303-675-2175 or 800-344-3860 Toll Free USA/Canada  
**Fax:** 303-675-2176 or 800-344-3867 Toll Free USA/Canada  
**Email:** ONlit@hibbertco.com  
 Fax Response Line: 303-675-2167 or 800-344-3810 Toll Free USA/Canada

**N. American Technical Support:** 800-282-9855 Toll Free USA/Canada

**EUROPE:** LDC for ON Semiconductor – European Support

**German Phone:** (+1) 303-308-7140 (Mon-Fri 2:30pm to 7:00pm CET)  
**Email:** ONlit-german@hibbertco.com  
**French Phone:** (+1) 303-308-7141 (Mon-Fri 2:00pm to 7:00pm CET)  
**Email:** ONlit-french@hibbertco.com  
**English Phone:** (+1) 303-308-7142 (Mon-Fri 12:00pm to 5:00pm GMT)  
**Email:** ONlit@hibbertco.com

**EUROPEAN TOLL-FREE ACCESS\*: 00-800-4422-3781**

\*Available from Germany, France, Italy, UK, Ireland

**CENTRAL/SOUTH AMERICA:**

**Spanish Phone:** 303-308-7143 (Mon-Fri 8:00am to 5:00pm MST)  
**Email:** ONlit-spanish@hibbertco.com  
**Toll-Free from Mexico:** Dial 01-800-288-2872 for Access –  
 then Dial 866-297-9322

**ASIA/PACIFIC:** LDC for ON Semiconductor – Asia Support

**Phone:** 303-675-2121 (Tue-Fri 9:00am to 1:00pm, Hong Kong Time)  
**Toll Free** from Hong Kong & Singapore:  
**001-800-4422-3781**  
**Email:** ONlit-asia@hibbertco.com

**JAPAN:** ON Semiconductor, Japan Customer Focus Center

4-32-1 Nishi-Gotanda, Shinagawa-ku, Tokyo, Japan 141-0031  
**Phone:** 81-3-5740-2700  
**Email:** r14525@onsemi.com

**ON Semiconductor Website:** <http://onsemi.com>

For additional information, please contact your local Sales Representative.



LittleDiode supplies new, hard to find or obsolete electronic components and semiconductors all over the world.

With over two million different components listed you are sure to find the part you need.

Feel free to visit us today at our online store:

[LittleDiode.com](http://LittleDiode.com)

Looking forward to providing you with the best possible service.