

# N-CHANNEL MOS FIELD EFFECT POWER TRANSISTOR

## 2SK699

**DESCRIPTION** The 2SK699 is N-Channel MOS Field Effect Power Transistor designed for solenoid, motor and lamp driver.

- FEATURES**
- 4 V Gate Drive — Logic level —
  - Low  $R_{DS(on)}$
  - No Second Breakdown

**ABSOLUTE MAXIMUM RATINGS**

- Maximum Temperatures**  
 Storage Temperature . . . . . -55 to +150 °C  
 Junction Temperature . . . . . 150 °C Maximum
- Maximum Power Dissipations**  
 Total Power Dissipation . . . . . 1.3 W  
 Total Power Dissipation ( $T_C = 25\text{ °C}$ ) . . . . . 15 W
- Maximum Voltages and Currents ( $T_A = 25\text{ °C}$ )**  
 $V_{DSS}$  Drain to Source Voltage . . . . . 100 V  
 $V_{GSS}$  Gate to Source Voltage . . . . . ±20 V  
 $I_{D(DC)}$  Drain Current (DC) . . . . . ±2 A  
 $I_{D(pulse)}$  Drain Current (pulse)\* . . . . . ±6 A
- \*  $PW \leq 300\ \mu s$ , Duty Cycle  $\leq 10\%$

**PACKAGE DIMENSIONS**  
in millimeters (inches)

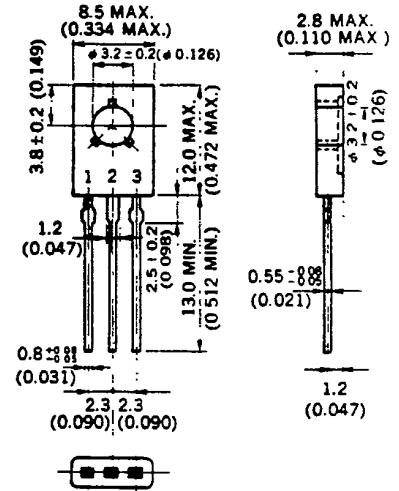

1. Source
2. Drain connected to mounting plane
3. Gate

**ELECTRICAL CHARACTERISTICS ( $T_A = 25\text{ °C}$ )**

SYMBOL	CHARACTERISTIC	MIN.	TYP.	MAX	UNIT	TEST CONDITIONS
$R_{DS(on)}$	Drain to Source On-State Resistance		0.8	1.2	$\Omega$	$V_{GS} = 10\text{ V}$ , $I_D = 1\text{ A}$
$R_{DS(on)}$	Drain to Source On-State Resistance		1.0	1.5	$\Omega$	$V_{GS} = 4\text{ V}$ , $I_D = 1\text{ A}$
$V_{GS(off)}$	Gate to Source Cutoff Voltage	1.0		2.5	V	$V_{DS} = 10\text{ V}$ , $I_D = 1\text{ mA}$
$Y_{fs}$	Forward Transfer Admittance	0.5			S	$V_{DS} = 10\text{ V}$ , $I_D = 1\text{ A}$
$I_{DSS}$	Drain Leakage Current			10	$\mu A$	$V_{DS} = 100\text{ V}$ , $V_{GS} = 0$
$I_{GSS}$	Gate to Source Leakage Current			±100	nA	$V_{GS} = \pm 20\text{ V}$ , $V_{DS} = 0$
$C_{iss}$	Input Capacitance		200		pF	$V_{DS} = 10\text{ V}$
$C_{oss}$	Output Capacitance		70		pF	$V_{GS} = 0$
$C_{rss}$	Reverse Transfer Capacitance		15		pF	$f = 1\text{ MHz}$
$t_{d(on)}$	Turn-On Delay Time		45		ns	$I_D = 1\text{ A}$ , $V_{CC} = 50\text{ V}$ $R_L = 50\ \Omega$ $R_{in} = 10\ \Omega$
$t_r$	Rise Time		40		ns	
$t_{d(off)}$	Turn-Off Delay Time		450		ns	
$t_f$	Fall Time		110		ns	

NEC cannot assume any responsibility for any circuits shown or represent that they are free from patent infringement

2SK699

TYPICAL CHARACTERISTICS ( $T_a = 25^\circ\text{C}$ )

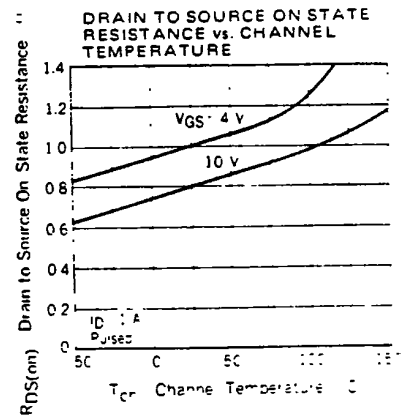
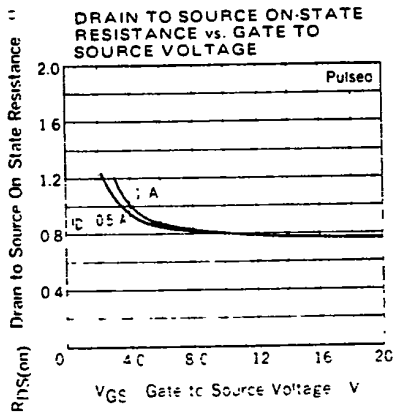
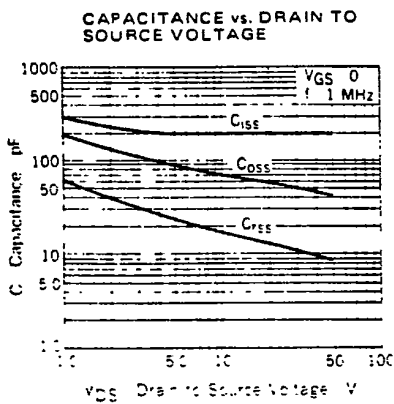
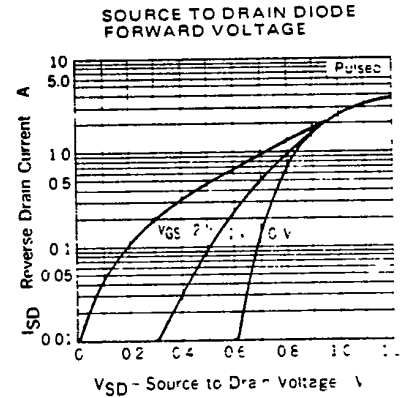
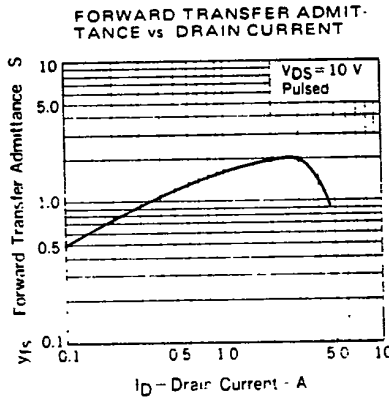
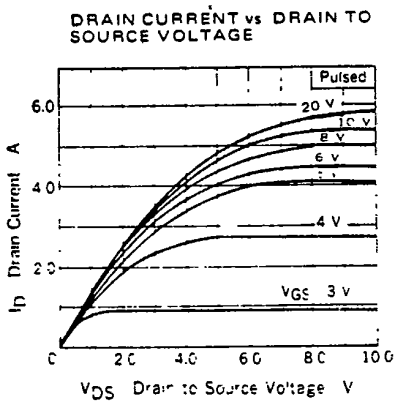
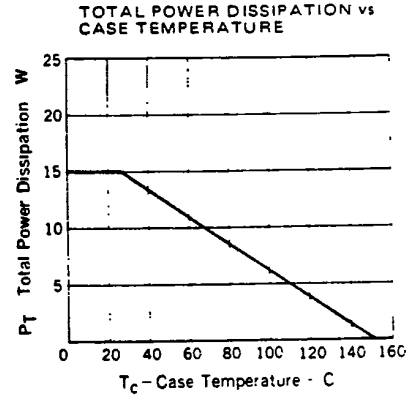
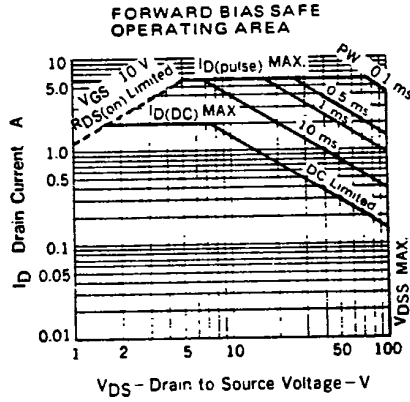
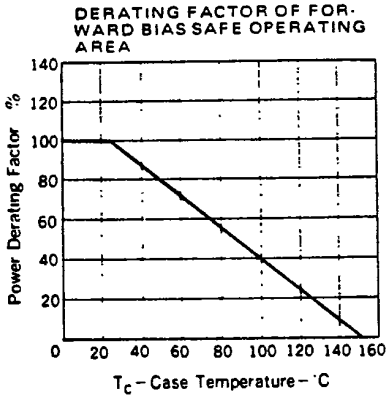

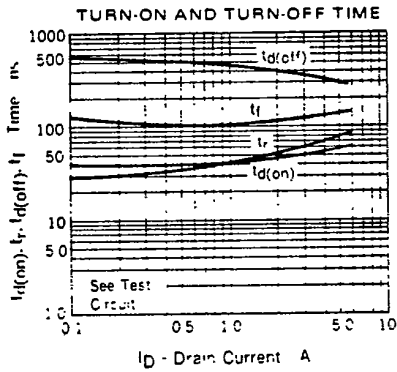
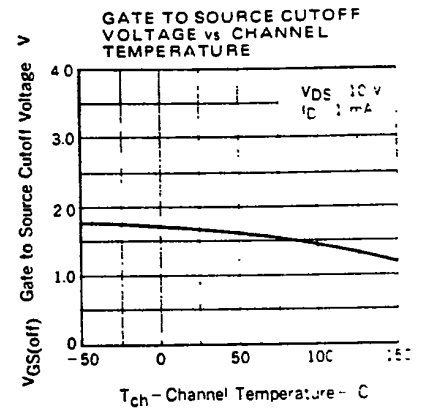
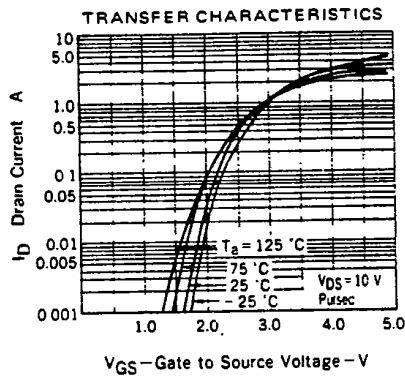
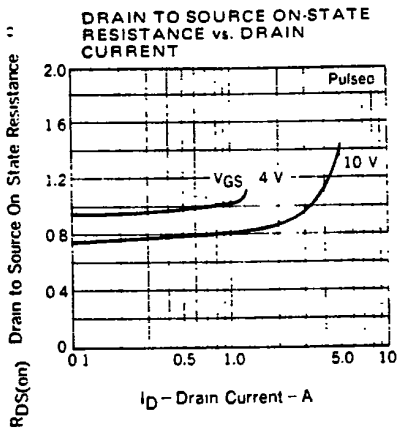

**TURN-ON AND TURN-OFF TIME TEST CIRCUIT**

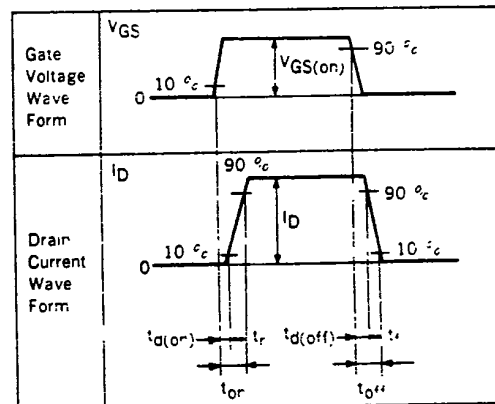
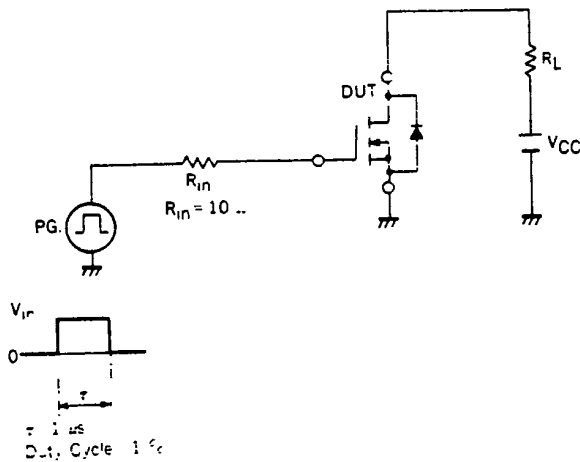

This datasheet has been downloaded from:

[www.DatasheetCatalog.com](http://www.DatasheetCatalog.com)

Datasheets for electronic components.



LittleDiode supplies new, hard to find or obsolete electronic components and semiconductors all over the world.

With over two million different components listed you are sure to find the part you need.

Feel free to visit us today at our online store:

**[LittleDiode.com](http://LittleDiode.com)**

Looking forward to providing you with the best possible service.