

36K, 64K, and 128K Serial EPROM Family

FEATURES

- Operationally equivalent to Xilinx® XC1700 family
- Wide voltage range 3.0 V to 6.0 V
- Maximum read current 10 mA at 5.0 V
- Standby current 100 μ A typical
- Industry standard Synchronous Serial Interface/ 1 bit per rising edge of clock
- Full Static Operation
- Sequential Read/Program
- Cascadable Output Enable
- 10 MHz Maximum Clock Rate @ 5.0 Vdc
- Programmable Polarity on Hardware Reset
- Programming with industry standard EPROM programmers
- Electrostatic discharge protection > 4,000 volts
- 8-pin PDIP/SOIC and 20-pin PLCC packages
- Data Retention > 200 years
- Temperature ranges:
 - Commercial: 0°C to +70°C
 - Industrial: -40°C to +85°C

DESCRIPTION

The Microchip Technology Inc. 37LV36/65/128 is a family of Serial OTP EPROM devices organized internally in a x32 configuration. The family also features a cascadable option for increased memory storage where needed. The 37LV36/65/128 is suitable for many applications in which look-up table information storage is desirable and provides full static operation in the 3.0V to 6.0V VCC range. The devices also support the industry standard serial interface to the popular RAM-based Field Programmable Gate Arrays (FPGA). Advanced CMOS technology makes this an ideal bootstrap solution for today's high speed SRAM-based FPGAs. The 37LV36/65/128 family is available in the standard 8-pin plastic DIP, 8-pin SOIC and 20-pin PLCC packages.

Device	Bits	Programming Word
37LV36	36,288	1134 x 32
37LV65	65,536	2048 x 32
37LV128	131,072	4096 x 32

PACKAGE TYPES

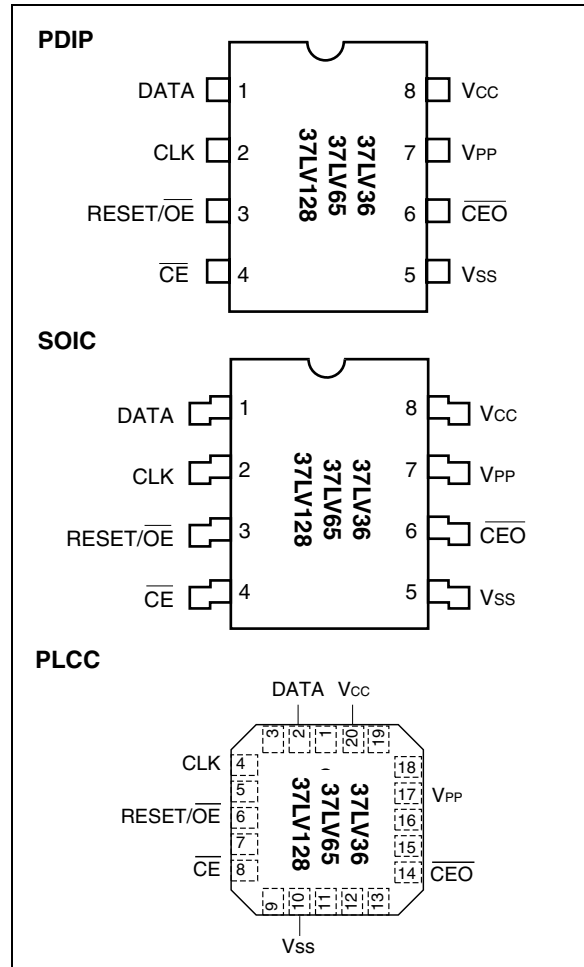

BLOCK DIAGRAM

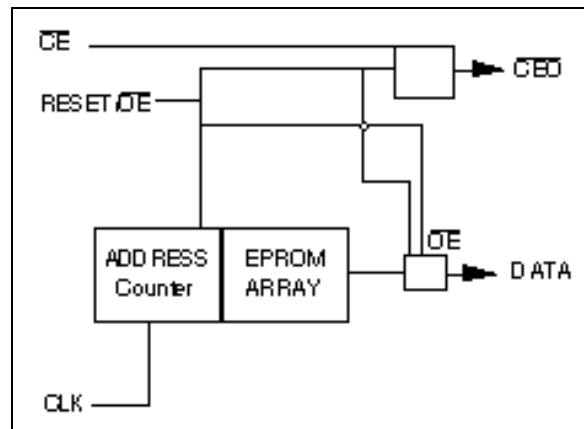

Xilinx is a registered trademark of Xilinx Corporation.

37LV36/65/128

1.0 ELECTRICAL CHARACTERISTICS

1.1 Maximum Ratings*

VCC and input voltages w.r.t. VSS -0.6V to +0.6V

VPP voltage w.r.t. VSS during programming -0.6V to +14.0V

Output voltage w.r.t. VSS -0.6V to VCC +0.6V

Storage temperature -65°C to +150°C

Ambient temp. with power applied..... -65°C to +125°C

Soldering temperature of leads (10 sec.) +300°C

ESD protection on all pins ≥ 4 kV

*Notice: Stresses above those listed under "Maximum Ratings" may cause permanent damage to the device. This is a stress rating only and functional operation of the device at those or any other conditions above those indicated in the operation listings of this specification is not implied. Exposure to maximum rating conditions for extended periods may affect device reliability.

TABLE 1-1: PIN FUNCTION TABLE

Name	Function	8	20
DATA	Data I/O	1	2
CLK	Clock Input	2	4
RESET/OE	Reset Input and Output Enable	3	6
\overline{CE}	Chip Enable Input	4	8
VSS	Ground	5	10
\overline{CEO}	Chip Enable Output	6	14
VPP	Programming Voltage Supply	7	17
VCC	+3.0V to 6.0V Power Supply	8	20
Not Labeled	Not utilized, not connected		

TABLE 1-2: READ OPERATION DC CHARACTERISTICS

VCC = +3.0 to 6.0V Commercial (C): Tamb = 0°C to +70°C Industrial (I): Tamb = -40°C to +85°C					
Parameter	Symbol	Min.	Max.	Units	Conditions
DATA, \overline{CE} , \overline{CEO} and Reset pins:					
High level input voltage	V _{IH}	2.0	V _{CC}	V	
Low level input voltage	V _{IL}	-0.3	0.8	V	
High level output voltage	V _{OH1}	3.86		V	I _{OH} = -4 mA V _{CC} ≥ 4.5V
	V _{OH2}	2.4		V	I _{OH} = -4 mA V _{CC} ≥ 3.0V
Low level output voltage	V _{OL}	—	.32	V	I _{OL} = 4.0 mA
Input Leakage	I _{LI}	-10	10	μA	V _{IN} = .1V to V _{CC}
Output Leakage	I _{LO}	-10	10	μA	V _{OUT} = .1V to V _{CC}
Input Capacitance (all inputs/outputs)	C _{INT}	—	10	pF	Tamb = 25°C; F _{CLK} = 1 MHz (Note 1)
Operating Current	I _{CC Read}	—	10	mA	V _{CC} = 6.0V, CLK = 10 MHz
		—	2	mA	V _{CC} = 3.6V, CLK = 2.5 MHz Outputs open
Standby Current	I _{CCS}	—	100	μA	V _{CC} = 6.0V, CE = 5.8V
			50	μA	V _{CC} = 3.6V, CE = 3.4V

Note 1: This parameter is initially characterized and not 100% tested.

2.0 DATA

2.1 Data I/O

Three-state DATA output for reading and input during programming.

3.0 CLK

3.1 Clock Input

Used to increment the internal address and bit counters for reading and programming.

4.0 RESET/ \overline{OE}

4.1 Reset Input and Output Enable

A LOW level on both the \overline{CE} and RESET/ \overline{OE} inputs enables the data output driver. A HIGH level on RESET/ \overline{OE} resets both the address and bit counters. In the 37LVXXX, the logic polarity of this input is programmable as either RESET/ \overline{OE} or \overline{OE} /RESET. This document describes the pin as RESET/ \overline{OE} although the opposite polarity is also possible. This option is defined and set at device program time.

5.0 \overline{CE}

5.1 Chip Enable Input

\overline{CE} is used for device selection. A LOW level on both \overline{CE} and \overline{OE} enables the data output driver. A HIGH level on \overline{CE} disables both the address and bit counters and forces the device into a low power mode.

6.0 \overline{CEO}

6.1 Chip Enable Output

This signal is asserted LOW on the clock cycle following the last bit read from the memory. It will stay LOW as long as \overline{CE} and \overline{OE} are both LOW. It will then follow \overline{CE} until \overline{OE} goes HIGH. Thereafter, \overline{CEO} will stay HIGH until the entire EPROM is read again. This pin also used to sense the status of RESET polarity when Programming Mode is entered.

7.0 VPP

7.1 Programming Voltage Supply

Used to enter programming mode (+13 volts) and to program the memory (+13 volts). Must be connected directly to Vcc for normal Read operation. No overshoot above +14 volts is permitted.

8.0 CASCADING SERIAL EPROMS

Cascading Serial EPROMs provide additional memory for multiple FPGAs configured as a daisy-chain, or for future applications requiring larger configuration memories.

When the last bit from the first Serial EPROM is read, the next clock signal to the Serial EPROM asserts its \overline{CEO} output LOW and disables its DATA line. The second Serial EPROM recognizes the LOW level on its \overline{CE} input and enables its DATA output.

When configuration is complete, the address counters of all cascaded Serial EPROMs are reset if RESET goes LOW forcing the RESET/ \overline{OE} on each Serial EPROM to go HIGH. If the address counters are not to be reset upon completion, then the RESET/ \overline{OE} inputs can be tied to ground.

Additional logic may be required if cascaded memories are so large that the rippled chip enable is not fast enough to activate successive Serial EPROMs.

9.0 STANDBY MODE

The 37LVXXX enters a low-power Standby Mode whenever \overline{CE} is HIGH. In Standby Mode, the Serial EPROM consumes less than 100 μ A of current. The output will remain in a high-impedance state regardless of the state of the \overline{OE} input.

10.0 PROGRAMMING MODE

Programming Mode is entered by holding VPP HIGH (+13 volts) for two clock edges and then holding VPP = VDD for one clock edge. Programming mode is exited by driving a LOW on both \overline{CE} and \overline{OE} and then removing power from the device. Figures 4 through 7 show the programming algorithm.

11.0 37LVXXX RESET POLARITY

The 37LVXXX lets the user choose the reset polarity as either RESET/ \overline{OE} or \overline{OE} /RESET. Any third-party commercial programmer should prompt the user for the desired reset polarity.

The programming of the overflow word should be handled transparently by the EPROM programmer; it is mentioned here as supplemental information only.

The polarity is programmed into the first overflow word location, maximum address+1. 00000000 in these locations makes the reset active LOW, FFFFFFFF in these locations makes the reset active HIGH. The default condition is RESET active HIGH.

FIGURE 11-1: READ CHARACTERISTICS TIMING

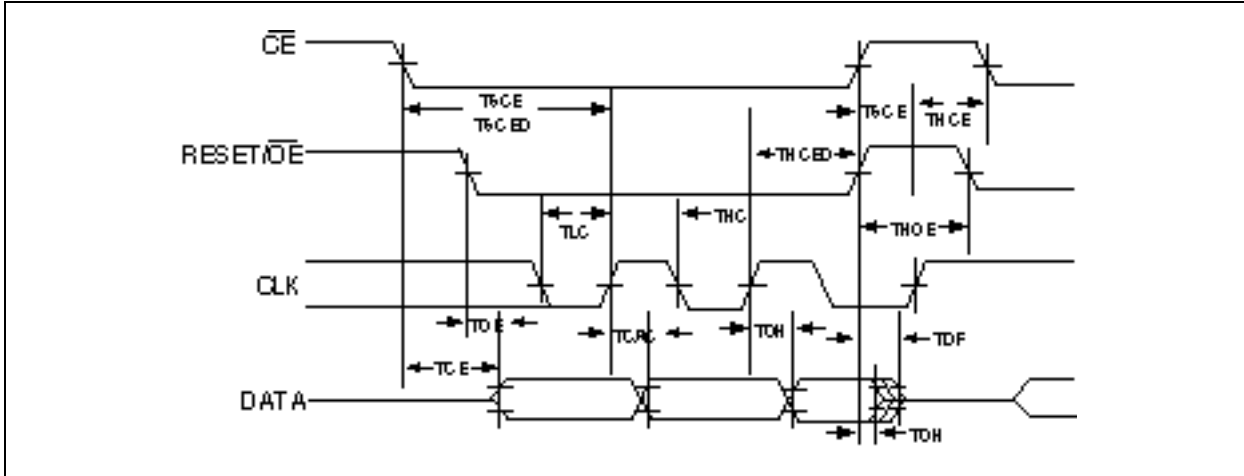

TABLE 11-1: READ CHARACTERISTICS

AC Testing Waveform: $V_{IL} = 0.2V$; $V_{IH} = 3.0V$ AC Test Load: 50 pF $V_{OL} = V_{OL_MAX}$; $V_{OH} = V_{OH_MIN}$							
Symbol	Parameter	Limits $3.0V \leq V_{CC} \leq 6.0V$		Limits $4.5V \leq V_{CC} \leq 6.0V$		Units	Conditions
		Min.	Max.	Min.	Max.		
TOE	\overline{OE} to Data Delay	—	45	—	45	ns	
TCE	\overline{CE} to Data Delay	—	60	—	50	ns	
TCAC	CLK to Data Delay	—	200	—	60	ns	
TOH	Data Hold from \overline{CE} , \overline{OE} or CLK	0	—	0	—	ns	
TDF	\overline{CE} or \overline{OE} to Data Float Delay	—	50	—	50	ns	Notes 1, 2
TLC	CLK Low Time	100	—	25	—	ns	
THC	CLK High Time	100	—	25	—	ns	
TSCE	\overline{CE} Set up Time to CLK (to guarantee proper counting)	40	—	25	—	ns	Note 1
TSCED	\overline{CE} setup time to CLK (to guarantee proper DATA read)	100	—	80	—	ns	
THCE	\overline{CE} Hold Time to CLK (to guarantee proper counting)	0	—	0	—	ns	Note 1
THCED	\overline{CE} hold time to CLK (to guarantee proper DATA read)	50	—	0	—	ns	
THOE	\overline{OE} High Time (Guarantees counters are Reset)	100	—	20	—	ns	
CLK max	Clock Frequency	—	2.5	—	10	MHz	

Note 1: This parameter is periodically sampled and not 100% tested.

2: Float delays are measured with output pulled through 1kΩ to $V_{LOAD} = V_{CC}/2$.

FIGURE 11-2: READ CHARACTERISTICS AT END OF ARRAY TIMING

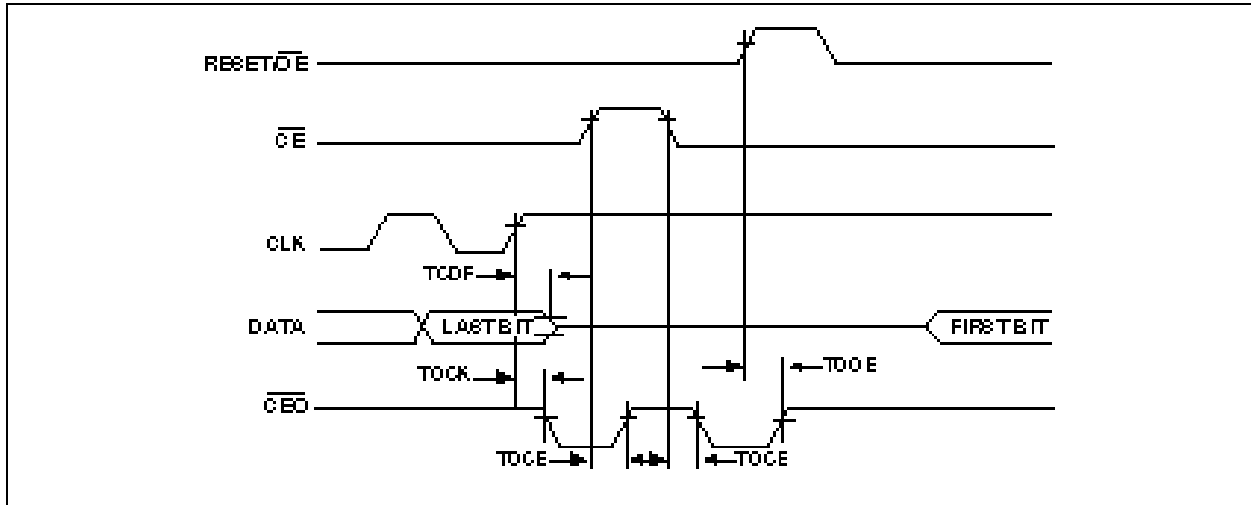

TABLE 11-2: READ CHARACTERISTICS AT END OF ARRAY

AC Testing Waveform: $V_{\text{IL}} = 0.2\text{V}$; $V_{\text{IH}} = 3.0\text{V}$ AC Test Load: 50 pF $V_{\text{OL}} = V_{\text{OL_MAX}}$; $V_{\text{OH}} = V_{\text{OH_MIN}}$							
Symbol	Parameter	Limits $3.0\text{V} \leq V_{\text{CC}} \leq 6.0\text{V}$		Limits $4.5\text{V} \leq V_{\text{CC}} \leq 6.0\text{V}$		Units	Conditions
		Min.	Max.	Min.	Max.		
T_{CDF}	CLK to Data Float Delay	—	50	—	50	ns	Notes 1, 2
T_{Ock}	CLK to $\overline{\text{CEO}}$ Delay	—	65	—	40	ns	
T_{Oce}	$\overline{\text{CE}}$ to $\overline{\text{CEO}}$ Delay	—	45	—	40	ns	
T_{Ooe}	$\overline{\text{RESET}}/\overline{\text{OE}}$ to $\overline{\text{CEO}}$ Delay	—	45	—	40	ns	

Note 1: This parameter is periodically sampled and not 100% tested.

Note 2: Float delays are measured with output pulled through $1\text{k}\Omega$ to $V_{\text{LOAD}} = V_{\text{CC}}/2$.

37LV36/65/128

TABLE 11-3: PIN ASSIGNMENTS IN THE PROGRAMMING MODE

DIP/SOIC Pin	PLCC Pin	Name	I/O	Description
1	2	DATA	I/O	The rising edge of the clock shifts a data word in or out of the EPROM one bit at a time.
2	4	CLK	I	Clock Input. Used to increment the internal address/word counter for reading and programming operation.
3	6	RESET/ \overline{OE}	I	The rising edge of CLK shifts a data word into the EPROM when \overline{CE} and \overline{OE} are HIGH; it shifts a data word out of the EPROM when \overline{CE} is LOW and \overline{OE} is HIGH. The address/word counter is incremented on the rising edge of CLK while \overline{CE} is held HIGH and \overline{OE} is held LOW. Note 1: Any modified polarity of the RESET/ \overline{OE} pin is ignored in the programming mode.
4	8	\overline{CE}	I	The rising edge of CLK shifts a data word into the EPROM when \overline{CE} and \overline{OE} are HIGH; it shifts a data word out of the EPROM when \overline{CE} is LOW and \overline{OE} is HIGH. The address/word counter is incremented on the rising edge of CLK while \overline{CE} is held HIGH and \overline{OE} is held LOW.
5	10	Vss		Ground pin.
6	14	\overline{CEO}	O	The polarity of the RESET/ \overline{OE} pin can be read by sensing the \overline{CEO} pin. Note 1: The polarity of the RESET/ \overline{OE} pin is ignored while in the Programming Mode. In final verification, this pin must be monitored to go LOW one clock cycle after the last data bit has been read.
7	17	VPP		Programming Voltage Supply. Programming Mode is entered by holding \overline{CE} and \overline{OE} HIGH and VPP at VPP1 for two rising clock edges and then lowering VPP to VPP2 for one more rising clock edge. A word is programmed by strobing the device with VPP for the duration TPGM. VPP must be tied to VCC for normal read operation.
8	20	VCC		+5 V power supply input.

TABLE 11-4: DC PROGRAMMING SPECIFICATIONS

Symbol	Parameter	Limits		Units
		Min.	Max.	
VCCP	Supply voltage during programming	5.0	6.0	V
VIL	Low-level input voltage	0.0	0.5	V
VIH	High-level input voltage	2.4	VCC	V
VOL	Low-level output voltage	—	0.4	V
VOH	High-level output voltage	3.7	—	V
VPP1	Programming voltage*	12.5	13.5	V
VPP2	Programming Mode access voltage	VCCP	VCCP+1	V
IPPP	Supply current in Programming Mode	—	100	mA
IL	Input or output leakage current	-10	10	μA
VCCL	First pass Low-level supply voltage for final verification	2.8	3.0	V
VCCH	Second pass High-level supply voltage for final verification	6.4	6.6	V

* No overshoot is permitted on this signal. VPP must not be allowed to exceed 14 volts.

TABLE 11-5: AC PROGRAMMING SPECIFICATIONS (SEE NOTE 2)

Symbol	Parameter	Limits		Units	Conditions
		Min.	Max.		
TRPP	10% to 90% Rise Time of VPP	1		μs	Note 1
TFPP	90% to 10% Fall Time of VPP	1		μs	Note 1
TPGM	VPP Programming Pulse Width	.50	1.05	ms	
TSVC	VPP Setup to CLK for Entering Programming Mode	100		ns	Note 1
TSVCE	\overline{CE} Setup to CLK for Entering Programming Mode	100		ns	Note 1
TSVOE	\overline{OE} Setup to CLK for Entering Programming Mode	100		ns	Note 1
THVC	VPP Hold from CLK for Entering Programming Mode	300		ns	Note 1
TSDP	Data Setup to CLK for Programming	50		ns	
THDP	Data Hold from CLK for Programming	0		ns	
TLCE	\overline{CE} Low time to clear data latches	100		ns	
TSCC	\overline{CE} Setup to CLK for Programming/Verifying	100		ns	
TSIC	\overline{OE} Setup to CLK for Incrementing Address Counter	100		ns	
THIC	\overline{OE} Hold from CLK for Incrementing Address Counter	0		ns	
THOV	\overline{OE} Hold from VPP	200		ns	Note 1
TPCAC	CLK to Data Valid		400	ns	
TPOH	Data Hold from CLK	0		ns	
TPCE	\overline{CE} Low to Data Valid		250	ns	

Note 1: This parameter is periodically sampled and not 100% tested.

Note 2: While in Programming Mode, \overline{CE} should only be changed while \overline{OE} is HIGH and has been HIGH for 200 ns, and \overline{OE} should only be changed while \overline{CE} is HIGH and has been HIGH for 200 ns.

FIGURE 11-6: READ MANUFACTURER AND DEVICE ID OVERVIEW

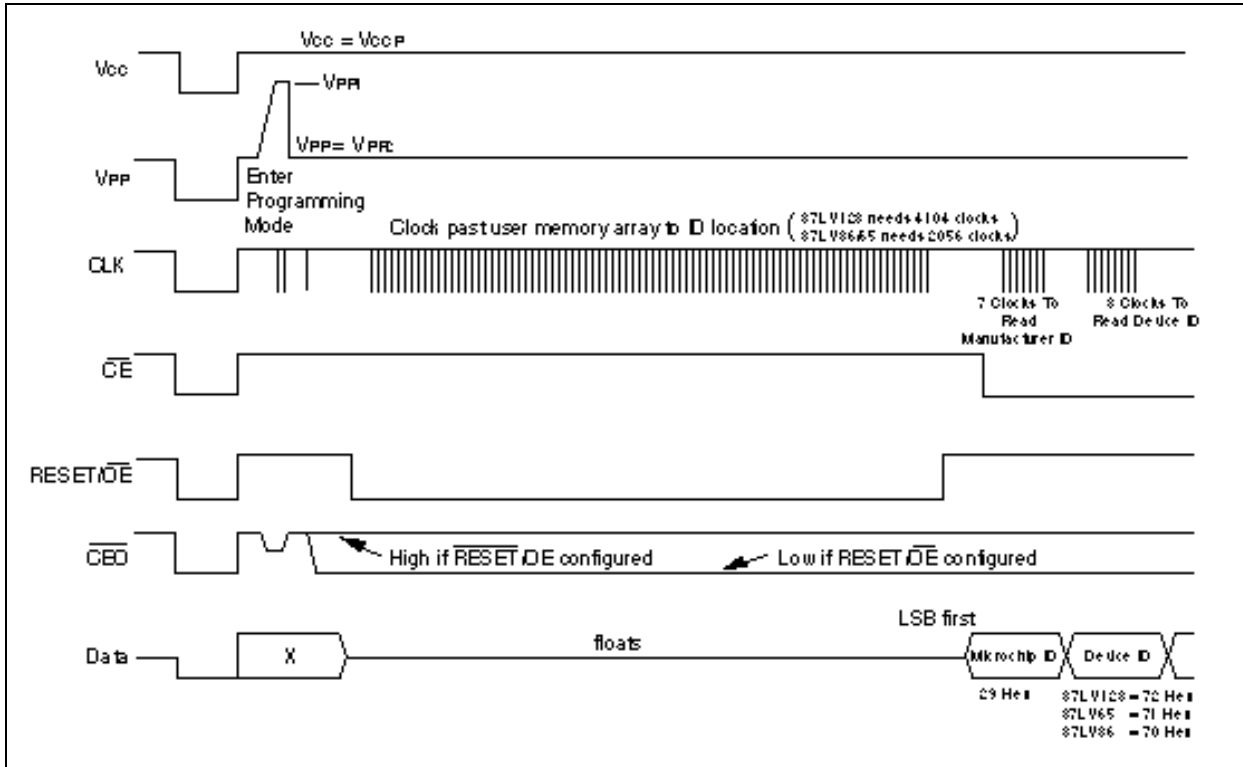

FIGURE 11-7: DETAILS OF READ MANUFACTURER AND DEVICE ID

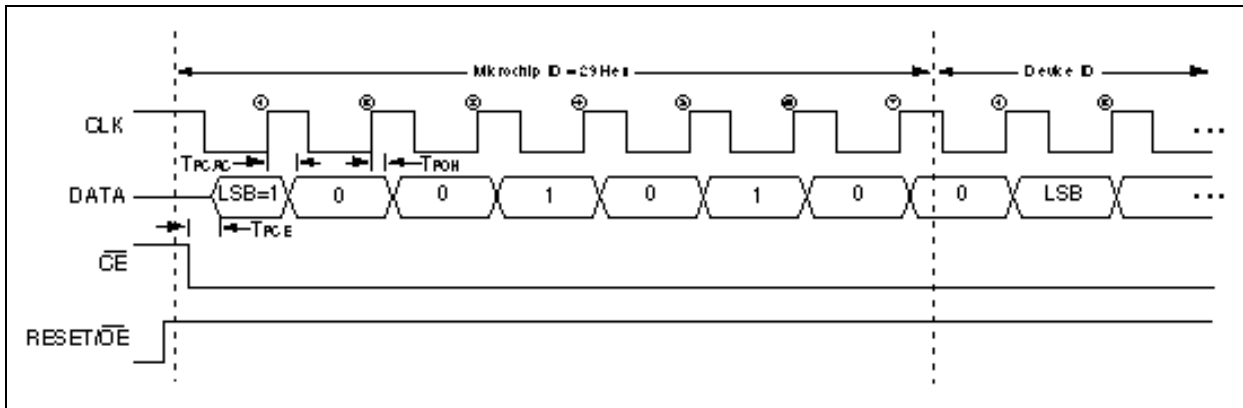
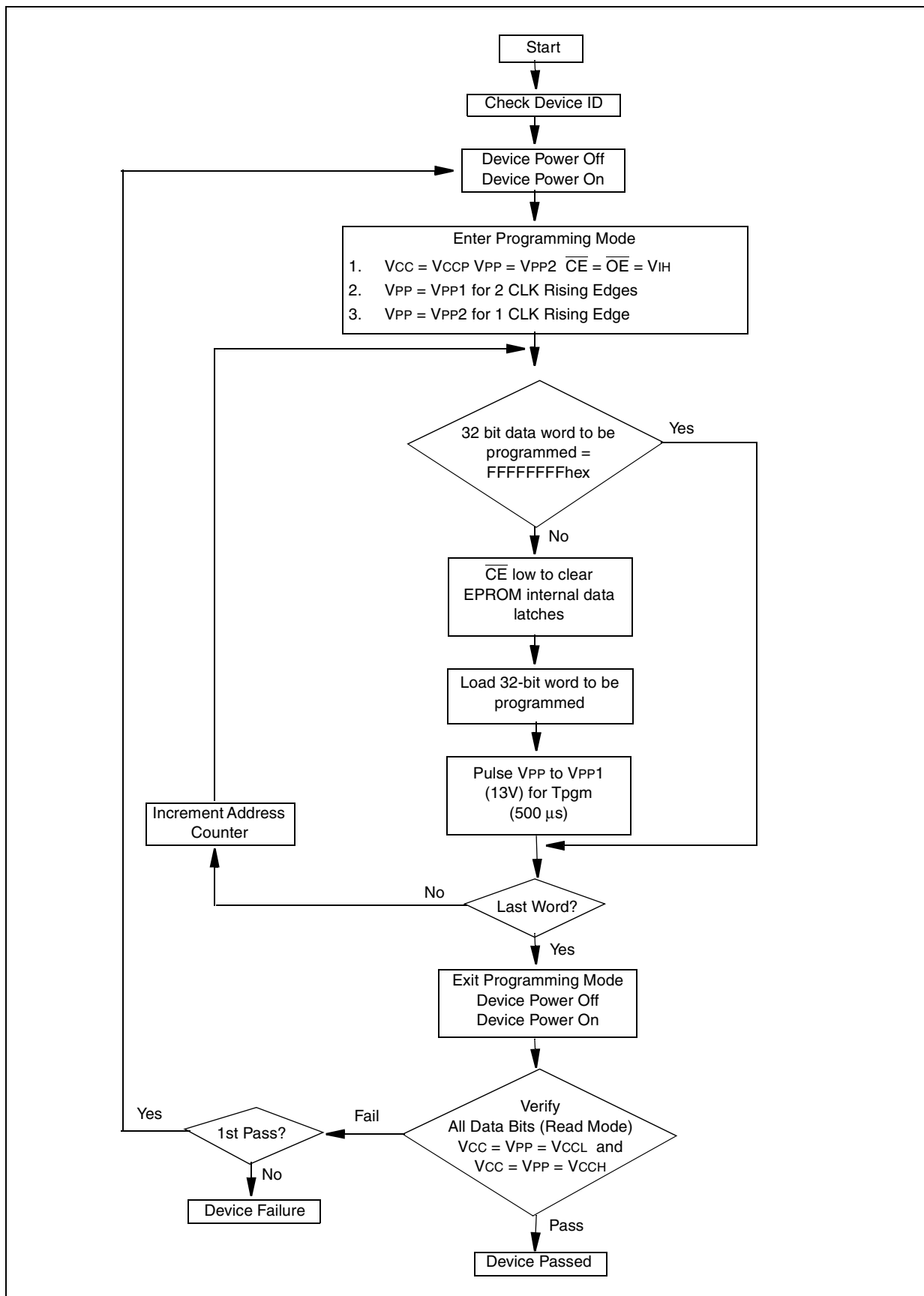
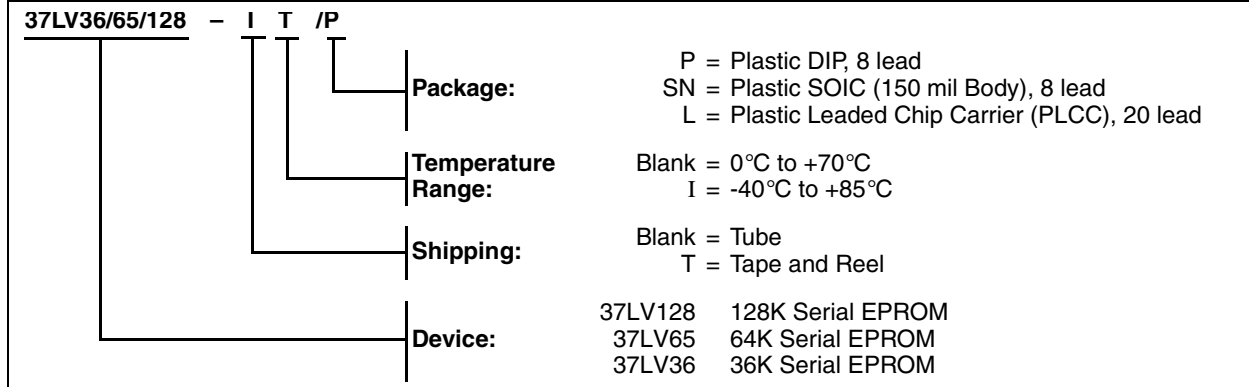

FIGURE 11-8: 37LVXXX PROGRAMMING SPECIFICATIONS



37LV36/65/128 Product Identification System

To order or to obtain information, e.g., on pricing or delivery, please use the listed part numbers, and refer to the factory or the listed sales offices.



Note the following details of the code protection feature on PICmicro® MCUs.

- The PICmicro family meets the specifications contained in the Microchip Data Sheet.
- Microchip believes that its family of PICmicro microcontrollers is one of the most secure products of its kind on the market today, when used in the intended manner and under normal conditions.
- There are dishonest and possibly illegal methods used to breach the code protection feature. All of these methods, to our knowledge, require using the PICmicro microcontroller in a manner outside the operating specifications contained in the data sheet. The person doing so may be engaged in theft of intellectual property.
- Microchip is willing to work with the customer who is concerned about the integrity of their code.
- Neither Microchip nor any other semiconductor manufacturer can guarantee the security of their code. Code protection does not mean that we are guaranteeing the product as “unbreakable”.
- Code protection is constantly evolving. We at Microchip are committed to continuously improving the code protection features of our product.

If you have any further questions about this matter, please contact the local sales office nearest to you.

Information contained in this publication regarding device applications and the like is intended through suggestion only and may be superseded by updates. It is your responsibility to ensure that your application meets with your specifications. No representation or warranty is given and no liability is assumed by Microchip Technology Incorporated with respect to the accuracy or use of such information, or infringement of patents or other intellectual property rights arising from such use or otherwise. Use of Microchip's products as critical components in life support systems is not authorized except with express written approval by Microchip. No licenses are conveyed, implicitly or otherwise, under any intellectual property rights.

Trademarks

The Microchip name and logo, the Microchip logo, FilterLab, KEELOQ, microID, MPLAB, PIC, PICmicro, PICMASTER, PICSTART, PRO MATE, SEEVAL and The Embedded Control Solutions Company are registered trademarks of Microchip Technology Incorporated in the U.S.A. and other countries.

dsPIC, ECONOMONITOR, FanSense, FlexROM, fuzzyLAB, In-Circuit Serial Programming, ICSP, ICEPIC, microPort, Migratable Memory, MPASM, MPLIB, MPLINK, MPSIM, MXDEV, PICC, PICDEM, PICDEM.net, rPIC, Select Mode and Total Endurance are trademarks of Microchip Technology Incorporated in the U.S.A.

Serialized Quick Turn Programming (SQTP) is a service mark of Microchip Technology Incorporated in the U.S.A.

All other trademarks mentioned herein are property of their respective companies.

© 2002, Microchip Technology Incorporated, Printed in the U.S.A., All Rights Reserved.

 Printed on recycled paper.

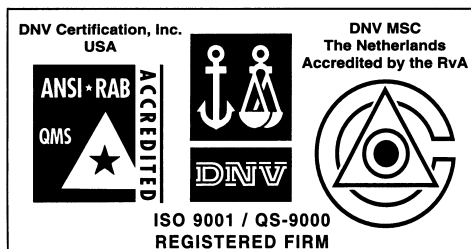

Microchip received QS-9000 quality system certification for its worldwide headquarters, design and wafer fabrication facilities in Chandler and Tempe, Arizona in July 1999. The Company's quality system processes and procedures are QS-9000 compliant for its PICmicro® 8-bit MCUs, KEELOQ® code hopping devices, Serial EEPROMs and microperipheral products. In addition, Microchip's quality system for the design and manufacture of development systems is ISO 9001 certified.



MICROCHIP

WORLDWIDE SALES AND SERVICE

AMERICAS

Corporate Office

2355 West Chandler Blvd.
Chandler, AZ 85224-6199
Tel: 480-792-7200 Fax: 480-792-7277
Technical Support: 480-792-7627
Web Address: <http://www.microchip.com>

Rocky Mountain

2355 West Chandler Blvd.
Chandler, AZ 85224-6199
Tel: 480-792-7966 Fax: 480-792-7456

Atlanta

500 Sugar Mill Road, Suite 200B
Atlanta, GA 30350
Tel: 770-640-0034 Fax: 770-640-0307

Boston

2 Lan Drive, Suite 120
Westford, MA 01886
Tel: 978-692-3848 Fax: 978-692-3821

Chicago

333 Pierce Road, Suite 180
Itasca, IL 60143
Tel: 630-285-0071 Fax: 630-285-0075

Dallas

4570 Westgrove Drive, Suite 160
Addison, TX 75001
Tel: 972-818-7423 Fax: 972-818-2924

Detroit

Tri-Atria Office Building
32255 Northwestern Highway, Suite 190
Farmington Hills, MI 48334
Tel: 248-538-2250 Fax: 248-538-2260

Kokomo

2767 S. Albright Road
Kokomo, Indiana 46902
Tel: 765-864-8360 Fax: 765-864-8387

Los Angeles

18201 Von Karman, Suite 1090
Irvine, CA 92612
Tel: 949-263-1888 Fax: 949-263-1338

New York

150 Motor Parkway, Suite 202
Hauppauge, NY 11788
Tel: 631-273-5305 Fax: 631-273-5335

San Jose

Microchip Technology Inc.
2107 North First Street, Suite 590
San Jose, CA 95131
Tel: 408-436-7950 Fax: 408-436-7955

Toronto

6285 Northam Drive, Suite 108
Mississauga, Ontario L4V 1X5, Canada
Tel: 905-673-0699 Fax: 905-673-6509

ASIA/PACIFIC

Australia

Microchip Technology Australia Pty Ltd
Suite 22, 41 Rawson Street
Epping 2121, NSW
Australia
Tel: 61-2-9868-6733 Fax: 61-2-9868-6755

China - Beijing

Microchip Technology Consulting (Shanghai)
Co., Ltd., Beijing Liaison Office
Unit 915
Bei Hai Wan Tai Bldg.
No. 6 Chaoyangmen Beidajie
Beijing, 100027, No. China
Tel: 86-10-85282100 Fax: 86-10-85282104

China - Chengdu

Microchip Technology Consulting (Shanghai)
Co., Ltd., Chengdu Liaison Office
Rm. 2401, 24th Floor,
Ming Xing Financial Tower
No. 88 TIDU Street
Chengdu 610016, China
Tel: 86-28-6766200 Fax: 86-28-6766599

China - Fuzhou

Microchip Technology Consulting (Shanghai)
Co., Ltd., Fuzhou Liaison Office
Unit 28F, World Trade Plaza
No. 71 Wusi Road
Fuzhou 350001, China
Tel: 86-591-7503506 Fax: 86-591-7503521

China - Shanghai

Microchip Technology Consulting (Shanghai)
Co., Ltd.
Room 701, Bldg. B
Far East International Plaza
No. 317 Xian Xia Road
Shanghai, 200051
Tel: 86-21-6275-5700 Fax: 86-21-6275-5060

China - Shenzhen

Microchip Technology Consulting (Shanghai)
Co., Ltd., Shenzhen Liaison Office
Rm. 1315, 13/F, Shenzhen Kerry Centre,
Renminnan Lu
Shenzhen 518001, China
Tel: 86-755-2350361 Fax: 86-755-2366086

Hong Kong

Microchip Technology Hongkong Ltd.
Unit 901-6, Tower 2, Metroplaza
223 Hing Fong Road
Kwai Fong, N.T., Hong Kong
Tel: 852-2401-1200 Fax: 852-2401-3431

India

Microchip Technology Inc.
India Liaison Office
Divyasree Chambers
1 Floor, Wing A (A3/A4)
No. 11, O'Shaugnessey Road
Bangalore, 560 025, India
Tel: 91-80-2290061 Fax: 91-80-2290062

Japan

Microchip Technology Japan K.K.
Benex S-1 6F
3-18-20, Shinyokohama
Kohoku-Ku, Yokohama-shi
Kanagawa, 222-0033, Japan
Tel: 81-45-471-6166 Fax: 81-45-471-6122

Korea

Microchip Technology Korea
168-1, Youngbo Bldg. 3 Floor
Samsung-Dong, Kangnam-Ku
Seoul, Korea 135-882
Tel: 82-2-554-7200 Fax: 82-2-558-5934

Singapore

Microchip Technology Singapore Pte Ltd.
200 Middle Road
#07-02 Prime Centre
Singapore, 188980
Tel: 65-334-8870 Fax: 65-334-8850

Taiwan

Microchip Technology Taiwan
11F-3, No. 207
Tung Hua North Road
Taipei, 105, Taiwan
Tel: 886-2-2717-7175 Fax: 886-2-2545-0139

EUROPE

Denmark

Microchip Technology Nordic ApS
Regus Business Centre
Lautrup hof 1-3
Ballerup DK-2750 Denmark
Tel: 45 4420 9895 Fax: 45 4420 9910

France

Microchip Technology SARL
Parc d'Activite du Moulin de Massy
43 Rue du Saule Trapu
Batiment A - 1er Etage
91300 Massy, France
Tel: 33-1-69-53-63-20 Fax: 33-1-69-30-90-79

Germany

Microchip Technology GmbH
Gustav-Heinemann Ring 125
D-81739 Munich, Germany
Tel: 49-89-627-144 0 Fax: 49-89-627-144-44

Italy

Microchip Technology SRL
Centro Direzionale Colleoni
Palazzo Taurus 1 V. Le Colleoni 1
20041 Agrate Brianza
Milan, Italy
Tel: 39-039-65791-1 Fax: 39-039-6899883

United Kingdom

Arizona Microchip Technology Ltd.
505 Eskdale Road
Winnersh Triangle
Wokingham
Berkshire, England RG41 5TU
Tel: 44 118 921 5869 Fax: 44-118 921-5820

01/18/02



LittleDiode supplies new, hard to find or obsolete electronic components and semiconductors all over the world.

With over two million different components listed you are sure to find the part you need.

Feel free to visit us today at our online store:

LittleDiode.com

Looking forward to providing you with the best possible service.