

54FCT/74FCT240 Inverting Octal Buffer/Line Driver with TRI-STATE® Outputs

General Description

The FCT240 is an inverting octal buffer and line driver designed to be employed as a memory address driver, clock driver and bus oriented transmitter or receiver which provides improved PC board density.

FACT™ FCT utilizes NSC quiet series technology to provide improved quiet output switching and dynamic threshold performance.

FACT FCT features GTO™ output control and undershoot corrector in addition to a split ground bus for superior performance.

Features

- I_{CC} and I_{OZ} reduced to 40.0 μA and $\pm 2.5 \mu A$ respectively
- NSC 54FCT/74FCT240 is pin and functionally equivalent to IDT 54FCT/74FCT240
- Inverting TRI-STATE outputs
- Input clamp diodes to limit bus reflections
- TTL/CMOS input and output level compatible
- $I_{OL} = 64 \text{ mA}$ (commercial), 48 mA (military)
- CMOS power levels
- ESD immunity $\geq 4 \text{ kV}$ typ
- Military product compliant to MIL-STD 883 and standard military drawing #5962-87655

Logic Symbol

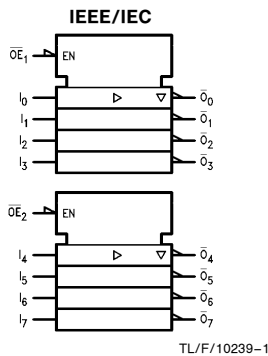

Connection Diagrams

Pin Assignment for DIP, Flatpak and SOIC

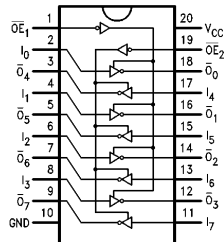

Pin Assignment for LCC

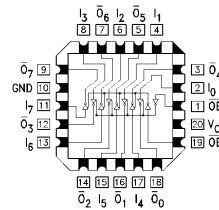

Pin Names	Description
$\overline{OE}_1, \overline{OE}_2$	TRI-STATE Output Enable Inputs
I_0-I_7	Inputs
O_0-O_7	Outputs

Truth Table

Inputs		Outputs (Pins 12, 14, 16, 18)
\overline{OE}_1	I	
L	L	H
L	H	L
H	X	Z

Inputs		Outputs (Pins 3, 5, 7, 9)
\overline{OE}_2	I	
L	L	H
L	H	L
H	X	Z

H = HIGH Voltage Level
L = LOW Voltage Level
X = Immaterial
Z = High Impedance

TRI-STATE® is a registered trademark of National Semiconductor Corporation.
FACT™ and GTO™ are trademarks of National Semiconductor Corporation.

Absolute Maximum Ratings (Note 1)

If Military/Aerospace specified devices are required, please contact the National Semiconductor Sales Office/Distributors for availability and specifications.

Terminal Voltage with Respect to GND (V_{TERM})		
74FCT	-0.5V to +7.0V	
54FCT	-0.5V to +7.0V	
Temperature under Bias (T_{BIAS})		
74FCT	-55°C to +125°C	
54FCT	-65°C to +135°C	
Storage Temperature (T_{STG})		
74FCT	-55°C to +125°C	
54FCT	-65°C to +150°C	
DC Output Current (I_{OUT})		120 mA

Note 1: Absolute maximum ratings are those values beyond which damage to the device may occur. Exposure to absolute maximum rating conditions for extended periods may affect reliability. The databook specifications should be met, without exception, to ensure that the system design is reliable over its power supply, temperature, and output/input loading variables.

Recommended Operating Conditions

Supply Voltage (V_{CC})		4.5V to 5.5V
54FCT		4.75V to 5.25V
74FCT		4.75V to 5.25V
Input Voltage		0V to V_{CC}
Output Voltage		0V to V_{CC}
Operating Temperature (T_A)		-55°C to +125°C
54FCT		-55°C to +125°C
74FCT		-0°C to +70°C
Junction Temperature (T_J)		
CDIP		175°C
PDIP		140°C

Note: All commercial packaging is not recommended for applications requiring greater than 2000 temperature cycles from -40°C to +125°C.

DC Characteristics for 'FCT Family Devices

Typical values are at $V_{CC} = 5.0V$, 25°C ambient and maximum loading. For test conditions shown as Max, use the value specified for the appropriate device type: Com: $V_{CC} = 5.0V \pm 5\%$, $T_A = 0^\circ C$ to $+70^\circ C$; Mil: $V_{CC} = 5.0V \pm 10\%$, $T_A = -55^\circ C$ to $+125^\circ C$, $V_{HC} = V_{CC} - 0.2V$.

Symbol	Parameter	54FCT/74FCT			Units	Conditions	
		Min	Typ	Max			
V_{IH}	Minimum High Level Input Voltage	2.0			V		
V_{IL}	Maximum Low Level Input Voltage			0.8	V		
I_{IH}	Input High Current			5.0 5.0	μA	$V_{CC} = \text{Max}$	$V_I = V_{CC}$ $V_I = 2.7V$ (Note 2)
I_{IL}	Input Low Current			-5.0 -5.0	μA	$V_{CC} = \text{Max}$	$V_I = 0.5V$ (Note 2) $V_I = \text{GND}$
I_{OZ}	Maximum TRI-STATE Current			2.5 2.5 -2.5 -2.5	μA	$V_{CC} = \text{Max}$	$V_O = V_{CC}$ $V_O = 2.7V$ (Note 2) $V_O = 0.5V$ (Note 2) $V_O = \text{GND}$
V_{IK}	Clamp Diode Voltage			-0.7 -1.2	V	$V_{CC} = \text{Min}; I_N = -18 \text{ mA}$	
I_{OS}	Short Circuit Current	-60	-120		mA	$V_{CC} = \text{Max}$ (Note 1); $V_O = \text{GND}$	
V_{OH}	Minimum High Level Output Voltage	2.8 V_{HC} 2.4 2.4	3.0 V_{CC} 4.3 4.3		V	$V_{CC} = 3V; V_{IN} = 0.2V$ or $V_{HC}; I_{OH} = -32 \mu A$	$I_{OH} = -300 \mu A$ $I_{OH} = -12 \text{ mA}$ (Mil) $I_{OH} = -15 \text{ mA}$ (Com)
V_{OL}	Maximum Low Level Output Voltage		GND 0.2 0.3 0.3	0.2 0.2 0.55 0.55	V	$V_{CC} = 3V; V_{IN} = 0.2V$ or $V_{HC}; I_{OL} = 300 \mu A$	$I_{OL} = 300 \mu A$ $I_{OL} = 48 \text{ mA}$ (Mil) $I_{OL} = 64 \text{ mA}$ (Com)
I_{CC}	Maximum Quiescent Supply Current		1.0	40.0	μA	$V_{CC} = \text{Max}$ $V_{IN} \geq V_{HC}, V_{IN} \leq 0.2V$ $f_i = 0$	
ΔI_{CC}	Quiescent Supply Current; TTL Inputs HIGH		0.5	2.0	mA	$V_{CC} = \text{Max}$ $V_{IN} = 3.4V$ (Note 3)	

DC Characteristics for 'FCT Family Devices (Continued)

Typical values are at $V_{CC} = 5.0V$, $25^{\circ}C$ ambient and maximum loading. For test conditions shown as Max, use the value specified for the appropriate device type: Com: $V_{CC} = 5.0V \pm 5\%$, $T_A = 0^{\circ}C$ to $+70^{\circ}C$; Mil: $V_{CC} = 5.0V \pm 10\%$, $T_A = -55^{\circ}C$ to $+125^{\circ}C$, $V_{HC} = V_{CC} - 0.2V$.

Symbol	Parameter	74FCT			Units	Conditions	
		Min	Typ	Max			
I_{CCD}	Dynamic Power Supply Current (Note 4)		0.25	0.55	mA/MHz	$V_{CC} = \text{Max}$ Outputs Open $\overline{OE}_1 = \overline{OE}_2 = \text{GND}$ One Input Toggling 50% Duty Cycle	$V_{IN} \geq V_{HC}$ $V_{IN} \leq 0.2V$
I_C	Total Power Supply Current (Note 6)		1.5	5.0	mA	$V_{CC} = \text{Max}$ Outputs Open $\overline{OE}_1 = \overline{OE}_2 = \text{GND}$ $f_i = 10 \text{ MHz}$ One Bit Toggling 50% Duty Cycle	$V_{IN} \geq V_{HC}$ $V_{IN} \leq 0.2V$
			1.8	6.0		$V_{IN} = 3.4V$ $V_{IN} = \text{GND}$	
			3.0	8.0		(Note 5) $V_{CC} = \text{Max}$ Outputs Open $\overline{OE}_1 = \overline{OE}_2 = \text{GND}$ $f_i = 2.5 \text{ MHz}$ Eight Bits Toggling 50% Duty Cycle	$V_{IN} \geq V_{HC}$ $V_{IN} \leq 0.2V$
			5.0	14.5		$V_{IN} = 3.4V$ $V_{IN} = \text{GND}$	

Note 1: Maximum test duration not to exceed one second, not more than one output shorted at one time.

Note 2: This parameter guaranteed but not tested.

Note 3: Per TTL driven input ($V_{IN} = 3.4V$); all other inputs at V_{CC} or GND.

Note 4: This parameter is not directly testable, but is derived for use in Total Power Supply calculations.

Note 5: Values for these conditions are examples of the I_{CC} formula. These limits are guaranteed but not tested.

Note 6: $I_C = I_{QUIESCENT} + I_{INPUTS} + I_{DYNAMIC}$

$$I_C = I_{CC} + \Delta I_{CC} D_H N_T + I_{CCD} (f_{CP}/2 + f_i N_i)$$

I_{CC} = Quiescent Current

ΔI_{CC} = Power Supply Current for a TTL High Input ($V_{IN} = 3.4V$)

D_H = Duty Cycle for TTL Inputs High

N_T = Number of Inputs at D_H

I_{CCD} = Dynamic Current Caused by an Input Transition Pair (HLH or LHL)

f_{CP} = Clock Frequency for Register Devices (Zero for Non-Register Devices)

f_i = Input Frequency

N_i = Number of Inputs at f_i

All currents are milliamps and all frequencies are in megahertz.

Note 7: For 54FCT, $I_{CCD} = 0.40 \text{ mA/MHz}$.

Refer to applicable standard military drawing or NSC Table I for test conditions and I_C/I_{CC} limits.

AC Electrical Characteristics

Symbol	Parameter	54FCT/74FCT	74FCT		54FCT		Units
		$T_A = +25^\circ\text{C}$ $V_{CC} = 5.0\text{V}$	$T_A, V_{CC} = \text{Com}$ $R_L = 500\Omega$ $C_L = 50\text{pF}$		$T_A, V_{CC} = \text{Mil}$ $R_L = 500\Omega$ $C_L = 50\text{pF}$		
		Typ	Min (Note 1)	Max	Min	Max	
t_{PLH} t_{PHL}	Propagation Delay D_n to O_n	5.0	1.5	8.0	1.5	9.0	ns
t_{PZH} t_{PZL}	Output Enable Time	7.0	1.5	10.0	1.5	10.5	ns
t_{PHZ} t_{PLZ}	Output Disable Time	6.0	1.5	9.5	1.5	12.5	ns

Note 1: Minimum limits are guaranteed but not tested on propagation delays.

Capacitance $T_A = +25^\circ\text{C}, f = 1.0\text{MHz}$

Symbol	Parameter (Note)	Typ	Max	Units	Condition
C_{IN}	Input Capacitance	6	10	pF	$V_{IN} = 0\text{V}$
C_{OUT}	Output Capacitance	8	12	pF	$V_{OUT} = 0\text{V}$

Note: This parameter is measured at characterization but not tested.
 C_{OUT} for 74FCT only.

Ordering Information

The device number is used to form part of a simplified purchasing code where the package type and temperature range are defined as follows:

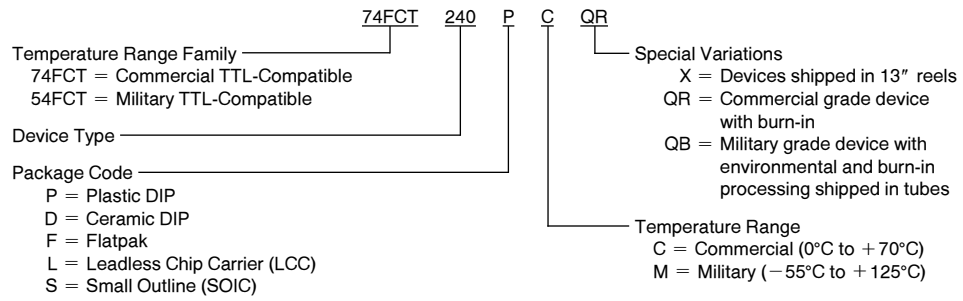

Physical Dimensions inches (millimeters)

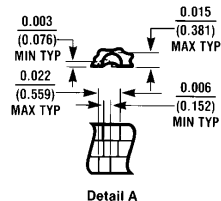
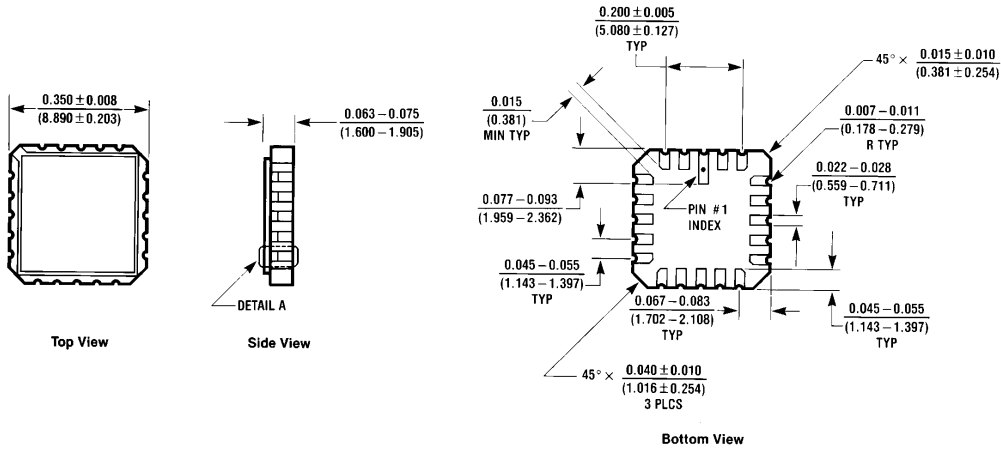

20-Terminal Ceramic Leadless Chip Carrier (L)
NS Package Number E20A

E20A (REV D)

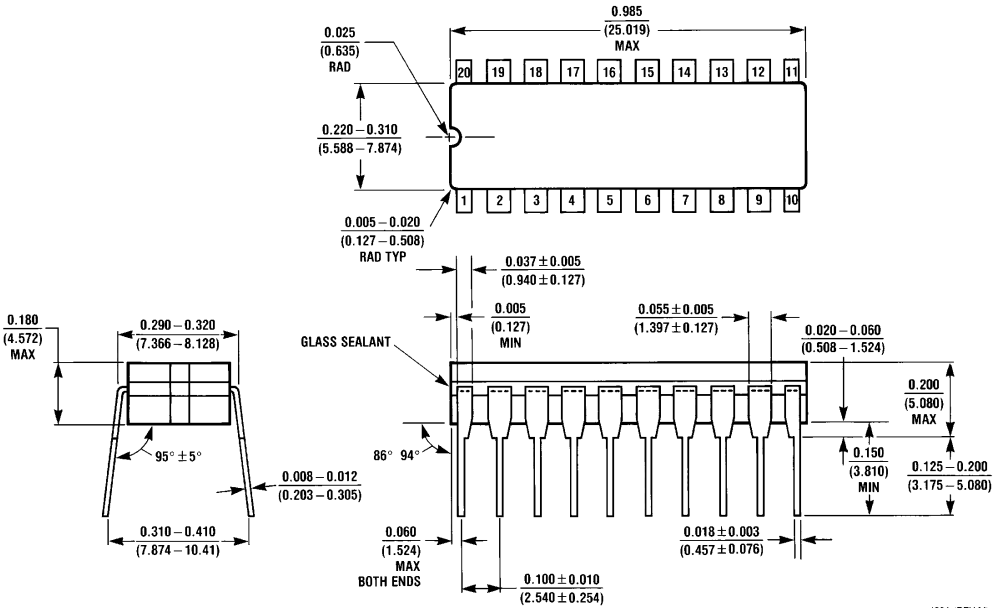

20-Lead Ceramic Dual-In-Line Package (D)
NS Package Number J20A

J20A (REV M)

Physical Dimensions inches (millimeters) (Continued)

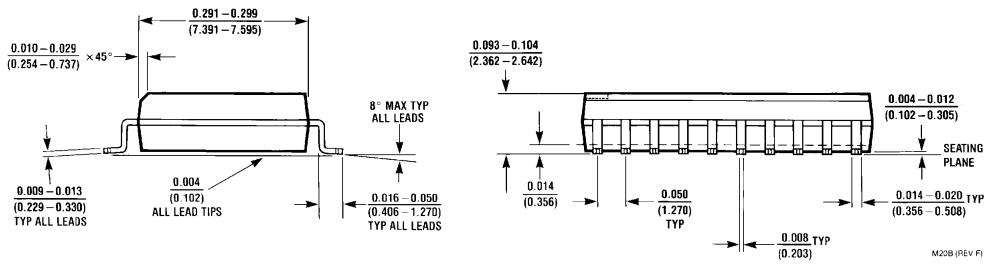
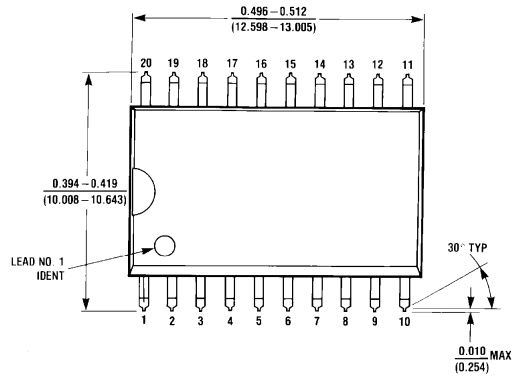

20-Lead Small Outline Integrated Circuit (S)
NS Package Number M20B

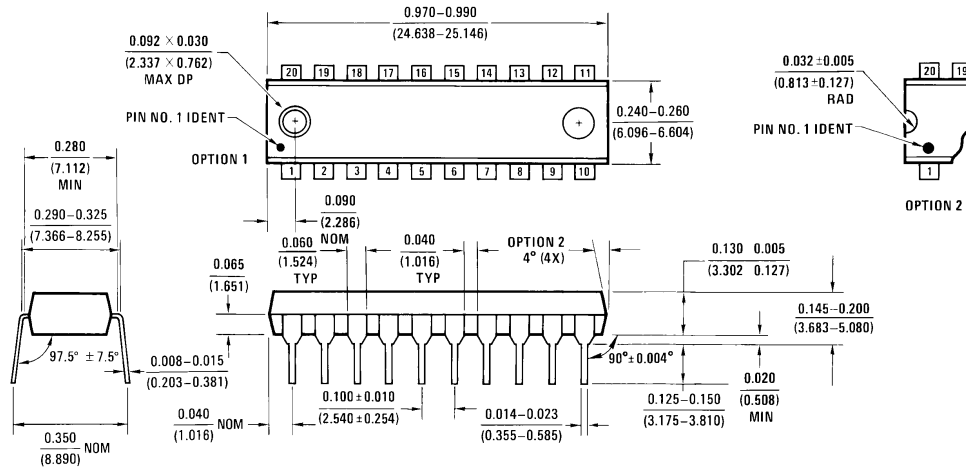

20-Lead Plastic Dual-In-Line Package (P)
NS Package Number N20B

Physical Dimensions inches (millimeters) (Continued)

Lit. # 114695

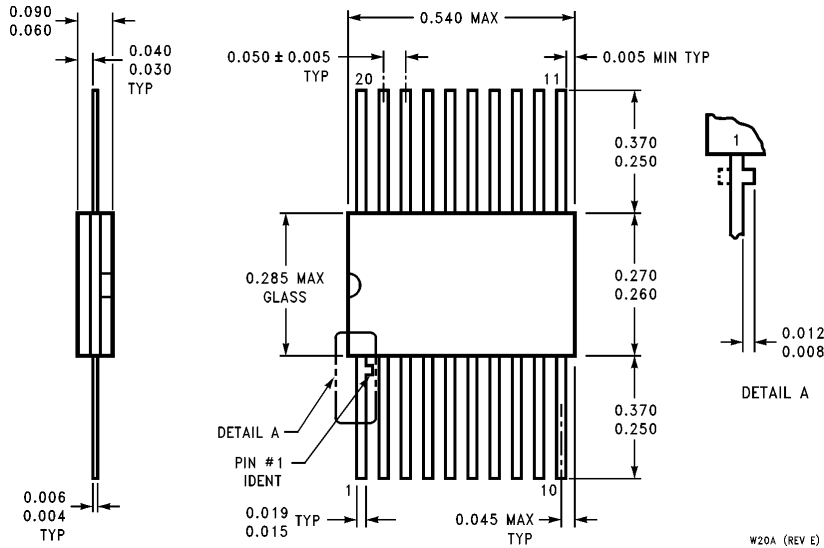

**20-Lead Ceramic Flatpak (F)
NS Package Number W20A**

W20A (REV E)

LIFE SUPPORT POLICY

NATIONAL'S PRODUCTS ARE NOT AUTHORIZED FOR USE AS CRITICAL COMPONENTS IN LIFE SUPPORT DEVICES OR SYSTEMS WITHOUT THE EXPRESS WRITTEN APPROVAL OF THE PRESIDENT OF NATIONAL SEMICONDUCTOR CORPORATION. As used herein:

1. Life support devices or systems are devices or systems which, (a) are intended for surgical implant into the body, or (b) support or sustain life, and whose failure to perform, when properly used in accordance with instructions for use provided in the labeling, can be reasonably expected to result in a significant injury to the user.
2. A critical component is any component of a life support device or system whose failure to perform can be reasonably expected to cause the failure of the life support device or system, or to affect its safety or effectiveness.



National Semiconductor Corporation
1111 West Bardin Road
Arlington, TX 76017
Tel: 1(800) 272-9959
Fax: 1(800) 737-7018

National Semiconductor Europe
Fax: (+49) 0-180-530 85 86
Email: cnjwge@tevm2.nsc.com
Deutsch Tel: (+49) 0-180-530 85 85
English Tel: (+49) 0-180-532 78 32
Français Tel: (+49) 0-180-532 93 58
Italiano Tel: (+49) 0-180-534 16 80

National Semiconductor Hong Kong Ltd.
19th Floor, Straight Block,
Ocean Centre, 5 Canton Rd.
Tsimshatsui, Kowloon
Hong Kong
Tel: (852) 2737-1600
Fax: (852) 2736-9960

National Semiconductor Japan Ltd.
Tel: 81-043-299-2309
Fax: 81-043-299-2408

National does not assume any responsibility for use of any circuitry described, no circuit patent licenses are implied and National reserves the right at any time without notice to change said circuitry and specifications.

National Semiconductor was acquired by Texas Instruments.

http://www.ti.com/corp/docs/investor_relations/pr_09_23_2011_national_semiconductor.html

This file is the datasheet for the following electronic components:

54FCT240 - <http://www.ti.com/product/54fct240?HQS=TI-null-null-dscatalog-df-pf-null-wwe>

74FCT240 - <http://www.ti.com/product/74fct240?HQS=TI-null-null-dscatalog-df-pf-null-wwe>



LittleDiode supplies new, hard to find or obsolete electronic components and semiconductors all over the world.

With over two million different components listed you are sure to find the part you need.

Feel free to visit us today at our online store:

LittleDiode.com

Looking forward to providing you with the best possible service.