

## 54LS85/DM54LS85/DM74LS85 4-Bit Magnitude Comparators

### General Description

These 4-bit magnitude comparators perform comparison of straight binary or BCD codes. Three fully-decoded decisions about two, 4-bit words (A, B) are made and are externally available at three outputs. These devices are fully expandable to any number of bits without external gates. Words of greater length may be compared by connecting comparators in cascade. The  $A > B$ ,  $A < B$ , and  $A = B$  outputs of a stage handling less-significant bits are connected to the corresponding inputs of the next stage handling more-significant bits. The stage handling the least-significant bits must

have a high-level voltage applied to the  $A = B$  input. The cascading path is implemented with only a two-gate-level delay to reduce overall comparison times for long words.

### Features

- Typical power dissipation 52 mW
- Typical delay (4-bit words) 24 ns
- Alternate Military/Aerospace device (54LS85) is available. Contact a National Semiconductor Sales Office/Distributor for specifications.

### Connection Diagram

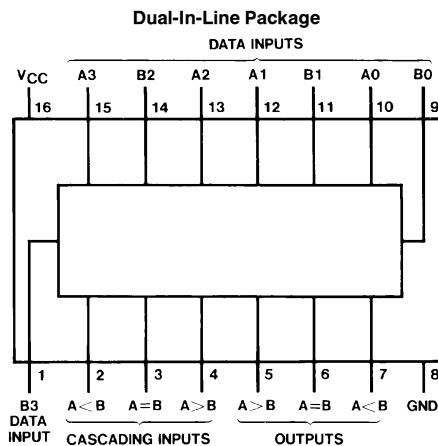

Order Number 54LS85DMQB,  
54LS85FMQB, 54LS85LMQB,  
DM54LS85J, DM54LS85W,  
DM74LS85M or DM74LS85N  
See NS Package Number E20A,  
J16A, M16A, N16E or W16A

TL/F/6379-1

### Function Table

Comparing Inputs				Cascading Inputs			Outputs		
A3, B3	A2, B2	A1, B1	A0, B0	A > B	A < B	A = B	A > B	A < B	A = B
A3 > B3	X	X	X	X	X	X	H	L	L
A3 < B3	X	X	X	X	X	X	L	H	L
A3 = B3	A2 > B2	X	X	X	X	X	H	L	L
A3 = B3	A2 < B2	X	X	X	X	X	L	H	L
A3 = B3	A2 = B2	A1 > B1	X	X	X	X	H	L	L
A3 = B3	A2 = B2	A1 < B1	X	X	X	X	L	H	L
A3 = B3	A2 = B2	A1 = B1	A0 > B0	X	X	X	H	L	L
A3 = B3	A2 = B2	A1 = B1	A0 < B0	X	X	X	L	H	L
A3 = B3	A2 = B2	A1 = B1	A0 = B0	H	L	L	H	L	L
A3 = B3	A2 = B2	A1 = B1	A0 = B0	L	H	L	L	H	L
A3 = B3	A2 = B2	A1 = B1	A0 = B0	L	L	H	L	L	H
A3 = B3	A2 = B2	A1 = B1	A0 = B0	X	X	H	L	L	H
A3 = B3	A2 = B2	A1 = B1	A0 = B0	H	H	L	L	L	L
A3 = B3	A2 = B2	A1 = B1	A0 = B0	L	L	L	H	H	L

H = High Level, L = Low Level, X = Don't Care

## Absolute Maximum Ratings (Note)

If Military/Aerospace specified devices are required, please contact the National Semiconductor Sales Office/Distributors for availability and specifications.

Supply Voltage	7V
Input Voltage	7V
Operating Free Air Temperature Range	
DM54LS and 54LS	−55°C to +125°C
DM74LS	0°C to +70°C
Storage Temperature Range	−65°C to +150°C

Note: The "Absolute Maximum Ratings" are those values beyond which the safety of the device cannot be guaranteed. The device should not be operated at these limits. The parametric values defined in the "Electrical Characteristics" table are not guaranteed at the absolute maximum ratings. The "Recommended Operating Conditions" table will define the conditions for actual device operation.

## Recommended Operating Conditions

Symbol	Parameter	DM54LS85			DM74LS85			Units
		Min	Nom	Max	Min	Nom	Max	
V <sub>CC</sub>	Supply Voltage	4.5	5	5.5	4.75	5	5.25	V
V <sub>IH</sub>	High Level Input Voltage	2			2			V
V <sub>IL</sub>	Low Level Input Voltage			0.7			0.8	V
I <sub>OH</sub>	High Level Output Current			−0.4			−0.4	mA
I <sub>OL</sub>	Low Level Output Current			4			8	mA
T <sub>A</sub>	Free Air Operating Temperature	−55		125	0		70	°C

## Electrical Characteristics over recommended operating free air temperature range (unless otherwise noted)

Symbol	Parameter	Conditions	Min	Typ (Note 1)	Max	Units
V <sub>I</sub>	Input Clamp Voltage	V <sub>CC</sub> = Min, I <sub>I</sub> = −18 mA			−1.5	V
V <sub>OH</sub>	High Level Output Voltage	V <sub>CC</sub> = Min, I <sub>OH</sub> = Max V <sub>IL</sub> = Max, V <sub>IH</sub> = Min	DM54 2.5	3.4		V
V <sub>OL</sub>	Low Level Output Voltage	V <sub>CC</sub> = Min, I <sub>OL</sub> = Max V <sub>IL</sub> = Max, V <sub>IH</sub> = Min	DM54	0.25	0.4	V
		I <sub>OL</sub> = 4 mA, V <sub>CC</sub> = Min	DM74	0.35	0.5	
I <sub>I</sub>	Input Current @ Max Input Voltage	V <sub>CC</sub> = Max V <sub>I</sub> = 7V	A < B		0.1	mA
			A > B		0.1	
			Others		0.3	
I <sub>IH</sub>	High Level Input Current	V <sub>CC</sub> = Max V <sub>I</sub> = 2.7V	A < B		20	μA
			A > B		20	
			Others		60	
I <sub>IL</sub>	Low Level Input Current	V <sub>CC</sub> = Max V <sub>I</sub> = 0.4V	A < B		−0.4	mA
			A > B		−0.4	
			Others		−1.2	
I <sub>OS</sub>	Short Circuit Output Current	V <sub>CC</sub> = Max (Note 2)	DM54	−20	−100	mA
			DM74	−20	−100	
I <sub>CC</sub>	Supply Current	V <sub>CC</sub> = Max (Note 3)		10	20	mA

Note 1: All typicals are at V<sub>CC</sub> = 5V, T<sub>A</sub> = 25°C.

Note 2: Not more than one output should be shorted at a time, and the duration should not exceed one second.

Note 3: I<sub>CC</sub> is measured with all outputs open, A = B grounded and all other inputs at 4.5V.

**Switching Characteristics** at  $V_{CC} = 5V$  and  $T_A = 25^\circ C$  (See Section 1 for Test Waveforms and Output Load)

Symbol	Parameter	From Input	To Output	Number of Gate Levels	$R_L = 2\text{ k}\Omega$				Units
					$C_L = 15\text{ pF}$		$C_L = 50\text{ pF}$		
					Min	Max	Min	Max	
$t_{PLH}$	Propagation Delay Time Low-to-High Level Output	Any A or B Data Input	A < B, A > B	3		36		42	ns
			A = B	4		40		40	
$t_{PHL}$	Propagation Delay Time High-to-Low Level Output	Any A or B Data Input	A < B, A > B	3		30		40	ns
			A = B	4		30		40	
$t_{PLH}$	Propagation Delay Time Low-to-High Level Output	A < B or A = B	A > B	1		22		26	ns
$t_{PHL}$	Propagation Delay Time High-to-Low Level Output	A < B or A = B	A > B	1		17		26	ns
$t_{PLH}$	Propagation Delay Time Low-to-High Level Output	A = B	A = B	2		20		25	ns
$t_{PHL}$	Propagation Delay Time High-to-Low Level Output	A = B	A = B	2		17		26	ns
$t_{PLH}$	Propagation Delay Time Low-to-High Level Output	A > B or A = B	A < B	1		22		26	ns
$t_{PHL}$	Propagation Delay Time High-to-Low Level Output	A > B or A = B	A < B	1		17		26	ns

**Logic Diagram**

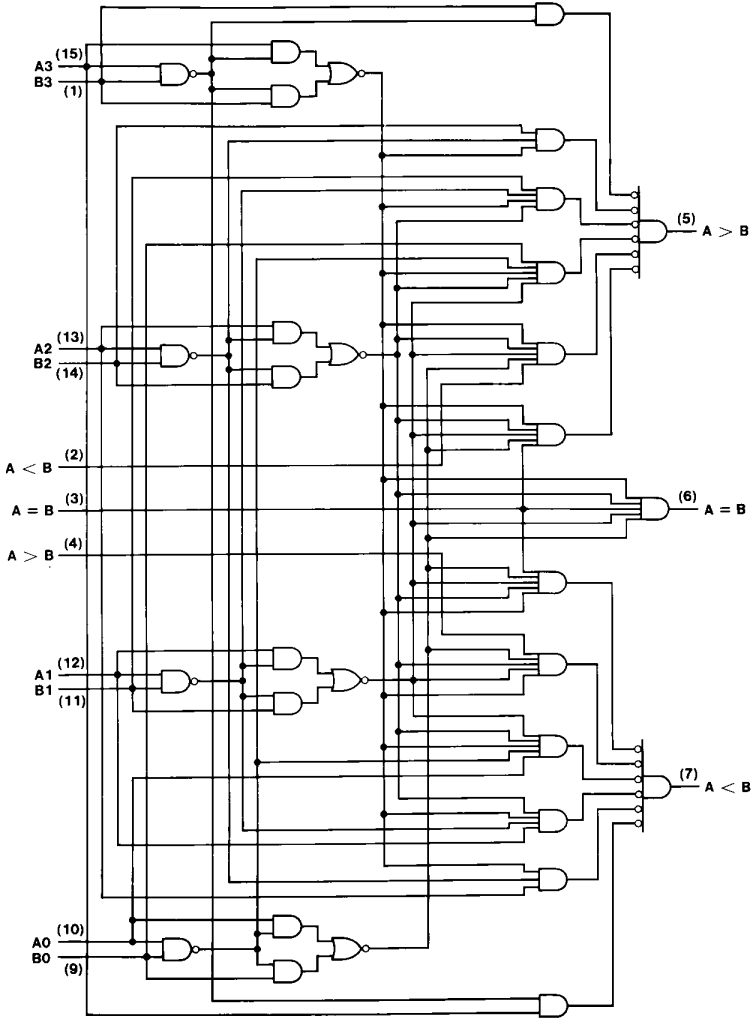

TL/F/6379-2

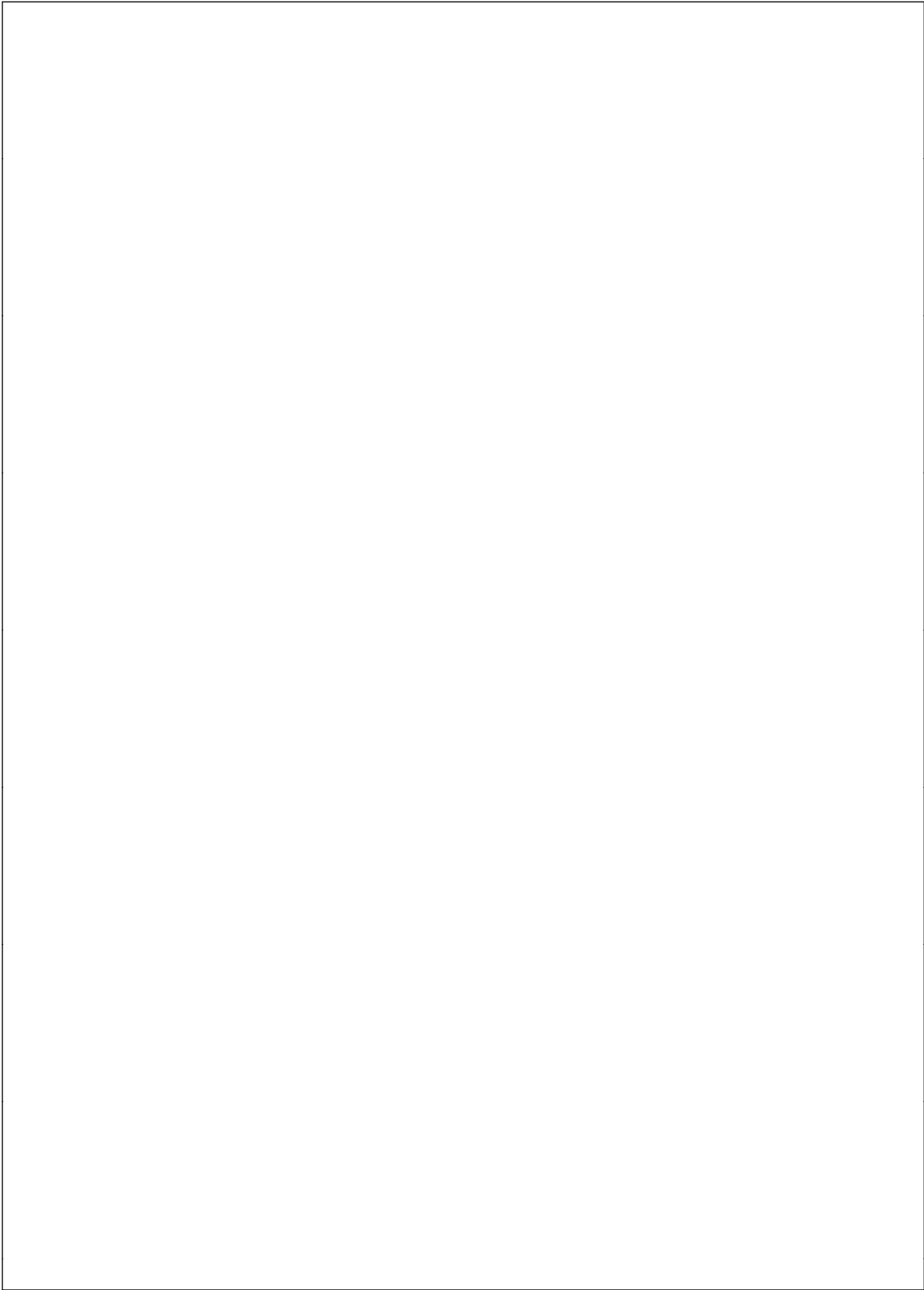

**Physical Dimensions** inches (millimeters)

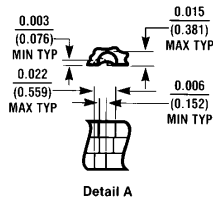
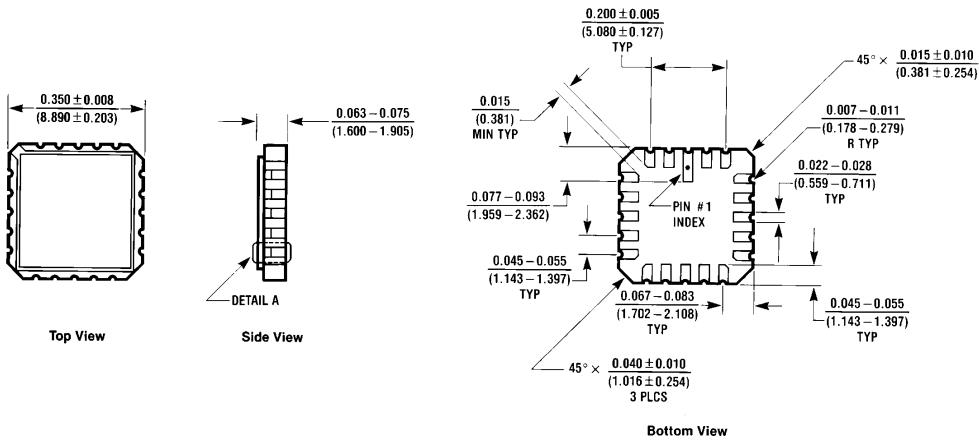

**Chip Carrier Package (E)**  
**Order Number 54LS85MQB**  
**NS Package Number E20A**

E20A (REV D)

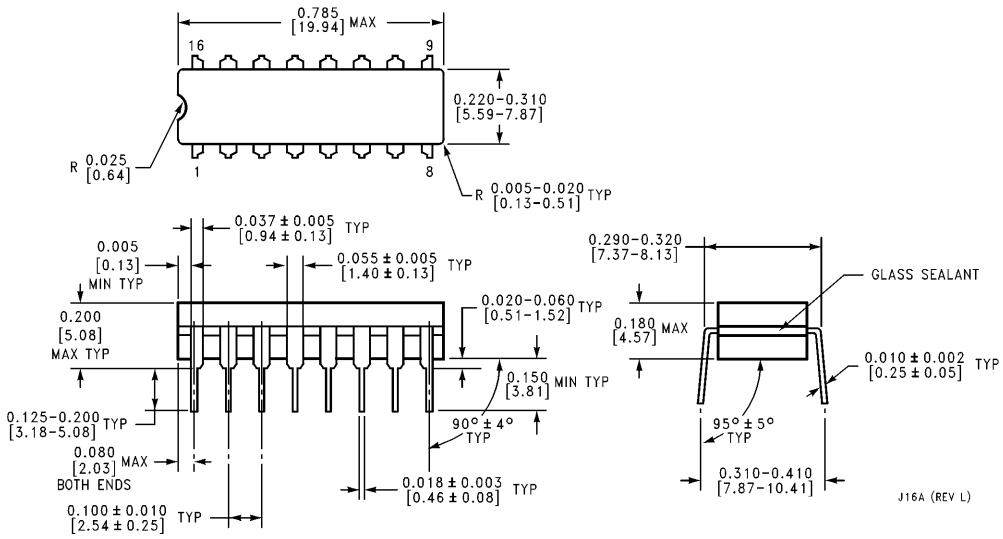

**16-Lead Ceramic Dual-In-Line Package (J)**  
**Order Number 54LS85DMQB or DM54LS85J**  
**NS Package Number J16A**

J16A (REV L)

**Physical Dimensions** inches (millimeters) (Continued)

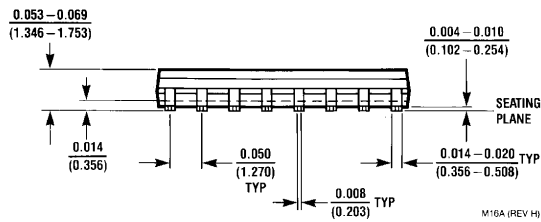
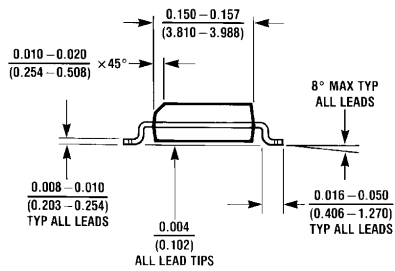
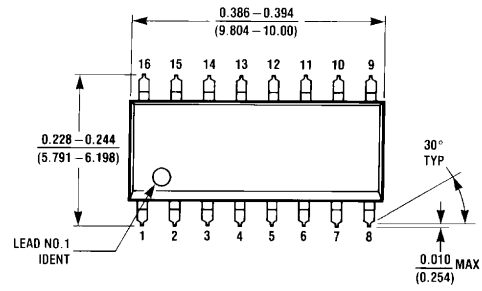

M16A (REV H)

**16-Lead Small Outline Molded Package (M)**  
**Order Number DM74LS85M**  
**NS Package Number M16A**

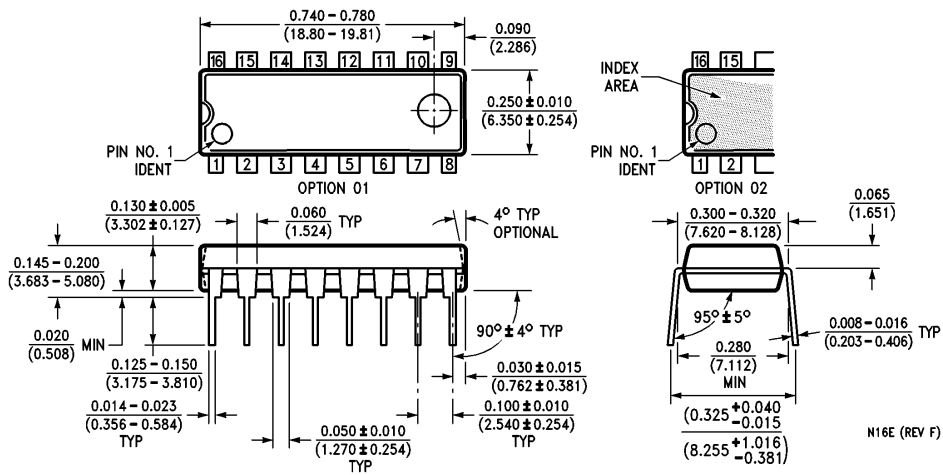

N16E (REV F)

**16-Lead Molded Dual-In-Line Package (N)**  
**Order Number DM74LS85N**  
**NS Package Number N16E**

**Physical Dimensions** inches (millimeters) (Continued)

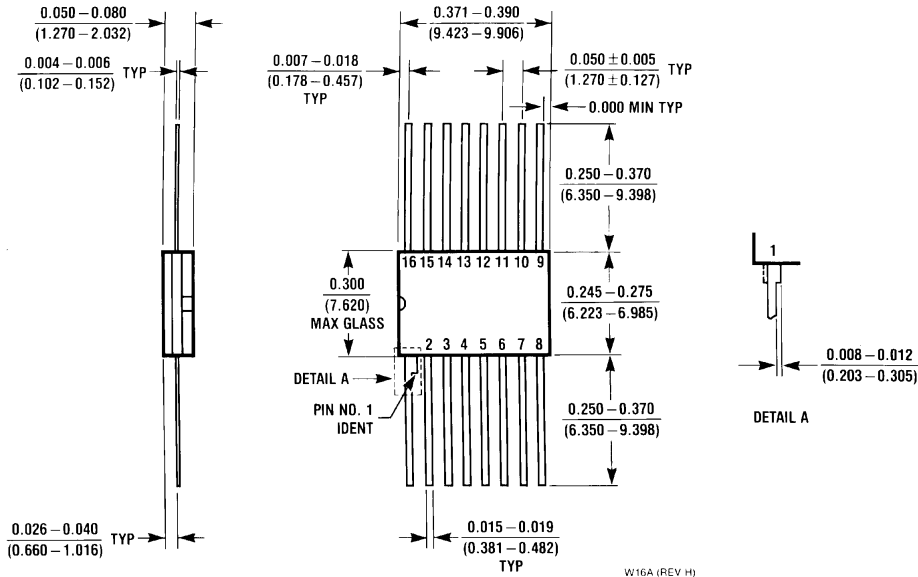

**16-Lead Ceramic Flat Package (W)**  
**Order Number 54LS85FMQB or DM54LS85W**  
**NS Package Number W16A**

**LIFE SUPPORT POLICY**

NATIONAL'S PRODUCTS ARE NOT AUTHORIZED FOR USE AS CRITICAL COMPONENTS IN LIFE SUPPORT DEVICES OR SYSTEMS WITHOUT THE EXPRESS WRITTEN APPROVAL OF THE PRESIDENT OF NATIONAL SEMICONDUCTOR CORPORATION. As used herein:

1. Life support devices or systems are devices or systems which, (a) are intended for surgical implant into the body, or (b) support or sustain life, and whose failure to perform, when properly used in accordance with instructions for use provided in the labeling, can be reasonably expected to result in a significant injury to the user.
2. A critical component is any component of a life support device or system whose failure to perform can be reasonably expected to cause the failure of the life support device or system, or to affect its safety or effectiveness.



**National Semiconductor Corporation**  
 1111 West Bardin Road  
 Arlington, TX 76017  
 Tel: 1(800) 272-9959  
 Fax: 1(800) 737-7018

**National Semiconductor Europe**  
 Fax: (+49) 0-180-530 85 86  
 Email: cnjwge@tevm2.nsc.com  
 Deutsch Tel: (+49) 0-180-530 85 85  
 English Tel: (+49) 0-180-532 78 32  
 Français Tel: (+49) 0-180-532 93 58  
 Italiano Tel: (+49) 0-180-534 16 80

**National Semiconductor Hong Kong Ltd.**  
 19th Floor, Straight Block,  
 Ocean Centre, 5 Canton Rd.  
 Tsimshatsui, Kowloon  
 Hong Kong  
 Tel: (852) 2737-1600  
 Fax: (852) 2736-9960

**National Semiconductor Japan Ltd.**  
 Tel: 81-043-299-2309  
 Fax: 81-043-299-2408

National does not assume any responsibility for use of any circuitry described, no circuit patent licenses are implied and National reserves the right at any time without notice to change said circuitry and specifications.

# National Semiconductor was acquired by Texas Instruments.

[http://www.ti.com/corp/docs/investor\\_relations/pr\\_09\\_23\\_2011\\_national\\_semiconductor.html](http://www.ti.com/corp/docs/investor_relations/pr_09_23_2011_national_semiconductor.html)

This file is the datasheet for the following electronic components:

54LS85 - <http://www.ti.com/product/54ls85?HQS=TI-null-null-dscatalog-df-pf-null-ww>

DM54LS85 - <http://www.ti.com/product/dm54ls85?HQS=TI-null-null-dscatalog-df-pf-null-ww>

DM74LS85 - <http://www.ti.com/product/dm74ls85?HQS=TI-null-null-dscatalog-df-pf-null-ww>



LittleDiode supplies new, hard to find or obsolete electronic components and semiconductors all over the world.

With over two million different components listed you are sure to find the part you need.

Feel free to visit us today at our online store:

[LittleDiode.com](http://LittleDiode.com)

Looking forward to providing you with the best possible service.