



MILITARY DATA SHEET

MNDS26LS32-X REV 2B0

Original Creation Date: 10/17/95
 Last Update Date: 10/21/96
 Last Major Revision Date: 04/08/96

QUAD DIFFERENTIAL LINE RECEIVERS

General Description

The DS26LS32 and DS26LS32A are quad differential line receivers designed to meet the RS-422, RS-423 and Federal Standards 1020 and 1030 for balanced and unbalanced digital data transmission.

The DS26LS32 and DS26LS32A have an input sensitivity of 200 mV over the input voltage range of $\pm 7V$ and the DS26LS33 and DS26LS33A have an input sensitivity of 500 mV over the input voltage range of $\pm 15V$.

Both the DS26LS32A and DS26LS33A differ in function from the popular DS26LS32 and DS26LS33 in that input pull-up and pull-down resistors are included which prevent output oscillation on unused channels.

Each version provides an enable and disable function common to all four receivers and features TRI-STATE outputs with 8mA sink capability. Constructed using low power Schottky processing, these devices are available over the full military and commercial operating temperature ranges.

Industry Part Number

DS26LS32

NS Part Numbers

DS26LS32ME/883
 DS26LS32MJ/883
 DS26LS32MW/883

Prime Die

DS26LS32

Controlling Document

5962-7802006QEA,QFA,Q2A

Processing

MIL-STD-883, Method 5004

Quality Conformance Inspection

MIL-STD-883, Method 5005

| Subgrp | Description | Temp (°C) |
|--------|---------------------|------------|
| 1 | Static tests at | +25 |
| 2 | Static tests at | +125 |
| 3 | Static tests at | -55 |
| 4 | Dynamic tests at | +25 |
| 5 | Dynamic tests at | +125 |
| 6 | Dynamic tests at | -55 |
| 7 | Functional tests at | +25 |
| 8A | Functional tests at | +125 |
| 8B | Functional tests at | -55 |
| 9 | Switching tests at | +25 |
| 10 | Switching tests at | +125 |
| 11 | Switching tests at | -55 |

Features

- High differential or common-mode input voltage ranges of $\pm 7V$ on the DS26LS32
- ± 0.2 sensitivity over the input voltage range on the DS26LS32
- Input fail-safe circuitry on the DS26LS32A.
- DS26LS32 meet all requirements of RS-422 and RS-423
- 6k minimum input impedance
- 100 mV input hysteresis on the DS26LS32
- Operation from a single 5V supply
- TRI-STATE drive, with choice of complementary output enables for receiving directly onto a data bus

(Absolute Maximum Ratings)

(Note 1)

| | |
|--|---------------|
| Supply Voltage | 7V |
| Common-Mode Range | $\pm 25V$ |
| Differential Input Voltage | $\pm 25V$ |
| Enable Voltage | 7V |
| Output Sink Current | 50 mA |
| Maximum Power Dissipation at 25C (Note 2) | |
| J package | 1666.5 mW |
| E package | 1875 mW |
| W package | 967.74 mW |
| Storage Temperature Range | -65C to +165C |
| Lead Temperature (Soldering, 4 Seconds) | 260C |

Note 1: "Absolute Maximum Rating" are those values beyond which the safety of the device cannot be guaranteed. They are not meant to imply that the device should be operated at these limits. The table of "Electrical Characteristics" provide conditions for actual device operation.

Note 2: Derate J package 11.11 mW/C above 25C; derate E package 12.5 mW/C above 25C. Derate W package: 6.4516 mW/C above 25C.

Recommended Operating Conditions

| | |
|-----------------------|----------------|
| Supply Voltage, (Vcc) | 4.50V to 5.50V |
| Temperature, (Ta) | -55C TO +125C |

Electrical Characteristics

DC PARAMETERS

(The following conditions apply to all the following parameters, unless otherwise specified.)
DC: VCC = 5V

| SYMBOL | PARAMETER | CONDITIONS | NOTES | PIN-NAME | MIN | MAX | UNIT | SUB-GROUPS |
|----------|------------------------------------|--|-------|----------|------|------|------|------------|
| IIN | Input Current | VCC=5.5V, VIN=15V (Pin under test), other inputs $-15V \leq VIN \leq +15V$ | 2 | | | 2.3 | mA | 1, 2, 3 |
| | | VCC=5.5V, VIN=-15V(Pin under test), other inputs $-15V \leq VIN \leq +15V$ | 2 | | | -2.8 | mA | 1, 2, 3 |
| IIL | Logical "0" ENABLE Current | VCC=5.5V, VIN= 0.4V | 2 | | | -360 | uA | 1, 2, 3 |
| IIH | Logical "1" ENABLE Current | VCC=5.5V, VIN=2.7V | 2 | | | 20 | uA | 1, 2, 3 |
| II | Logical "1" ENABLE Current | VCC=5.5V, VIN=5.5V | 2 | | | 100 | uA | 1, 2, 3 |
| VIC | Input Clamp Voltage (ENABLE) | VCC=4.5V, IIN=-18mA | 2 | | | -1.5 | V | 1, 2, 3 |
| VOH | Logical "1" Output Voltage | VCC=4.5V, IOH=-440uA, DELTA VIN = 1V, VENABLE = 0.8V | 2 | | 2.5 | | V | 1, 2, 3 |
| VOL | Logical "0" Output Voltage | VCC=4.5V, IOL= 4mA, DELTA VIN = -1V, VENABLE = 0.8V | 2 | | | .4 | V | 1, 2, 3 |
| | | VCC=4.5V, IOL= 8mA, DELTA VIN = -1V, VENABLE = 0.8V | 2 | | | .45 | V | 1, 2, 3 |
| IOS(MIN) | Output Short Circuit Current | VCC = 5.5V, VO=0V, DELTA VIN = 1V | 2 | | -15 | | mA | 1, 2, 3 |
| IOS(MAX) | Output Short Circuit Current | VCC = 5.5V, VO=0V, DELTA VIN = 1V | 2 | | | -85 | mA | 1, 2, 3 |
| ICC | Supply Current | VCC = 5.5V, All VIN = GND, Outputs Disabled | 2 | | | 70 | mA | 1, 2, 3 |
| IOFF | Off-State Output Current | VCC = 5.5V, VO= 0.4V | 2 | | | -20 | uA | 1, 2, 3 |
| | | VCC = 5.5V, VO= 2.4V | 2 | | | 20 | uA | 1, 2, 3 |
| VTH | Differential Input Voltage | $-7V \leq VCM \leq 7V$ | 1, 2 | | -0.2 | 0.2 | V | 1, 2, 3 |
| RIN | Input Resistance | $-15V \leq VCM \leq 15V$ | 2 | | 6 | | kohm | 1, 2, 3 |
| VIL | Logical "0" Input Voltage (ENABLE) | VCC= 4.5V | 1, 2 | | | 0.8 | V | 1, 2, 3 |
| VIH | Logical "1" Input Voltage (ENABLE) | VCC= 4.5V | 1, 2 | | 2 | | V | 1, 2, 3 |

Electrical Characteristics

AC PARAMETERS PROPAGATION DELAY TIME:

(The following conditions apply to all the following parameters, unless otherwise specified.)
AC: VCC=5V

| SYMBOL | PARAMETER | CONDITIONS | NOTES | PIN-NAME | MIN | MAX | UNIT | SUB-GROUPS |
|--------|------------------------|------------------------------------|-------|----------|-----|-----|------|------------|
| tPLH | Propagation Delay Time | Cl=15pF | 3 | | | 30 | nS | 9, 11 |
| | | | 3 | | | 120 | nS | 10 |
| tPHL | Propagation Delay Time | Cl=15pF | 3 | | | 30 | nS | 9, 11 |
| | | | 3 | | | 120 | nS | 10 |
| tLZ | Enable Time | $\overline{\text{ENABLE}}$ Cl=5pF | 3 | | | 34 | nS | 9 |
| | | $\overline{\text{ENABLE}}$ Cl=5pF | 3 | | | 64 | nS | 10 |
| | | $\overline{\text{ENABLE}}$ Cl=5pF | 3 | | | 27 | nS | 11 |
| tHZ | Enable Time | $\overline{\text{ENABLE}}$ Cl=5pF | 3 | | | 32 | nS | 9, 11 |
| | | $\overline{\text{ENABLE}}$ Cl=5pF | 3 | | | 35 | nS | 10 |
| tZL | Disable Time | $\overline{\text{ENABLE}}$ Cl=15pF | 3 | | | 34 | nS | 9 |
| | | $\overline{\text{ENABLE}}$ Cl=15pF | 3 | | | 65 | nS | 10 |
| | | $\overline{\text{ENABLE}}$ Cl=15pF | 3 | | | 27 | nS | 11 |
| tZH | Disable Time | $\overline{\text{ENABLE}}$ Cl=15pF | 3 | | | 35 | nS | 9 |
| | | $\overline{\text{ENABLE}}$ Cl=15pF | 3 | | | 65 | nS | 10 |
| | | $\overline{\text{ENABLE}}$ Cl=15pF | 3 | | | 27 | nS | 11 |

Note 1: Parameter tested go-no-go only.

Note 2: For Subgroups 1 and 2: Power dissipation must be externally controlled at elevated temperatures.

Note 3: Tested at 25C, guaranteed but not tested at +125C & -55C.

Graphics and Diagrams

| GRAPHICS# | DESCRIPTION |
|-----------|--|
| E20ARE | LDLESS CHIP CARRIER, TYPE C 20 TERMINAL(P/P DWG) |
| J16ARL | CERDIP (J), 16 LEAD (P/P DWG) |
| W16ARL | CERPAC (W), 16 LEAD (P/P DWG) |

See attached graphics following this page.

| REVISIONS | | | |
|-----------|-------------------|--------|---------------|
| LTR | DESCRIPTION | E.C.N. | DATE |
| E | REVISE AND REDRAW | 10005 | 02/10/94 DEG/ |

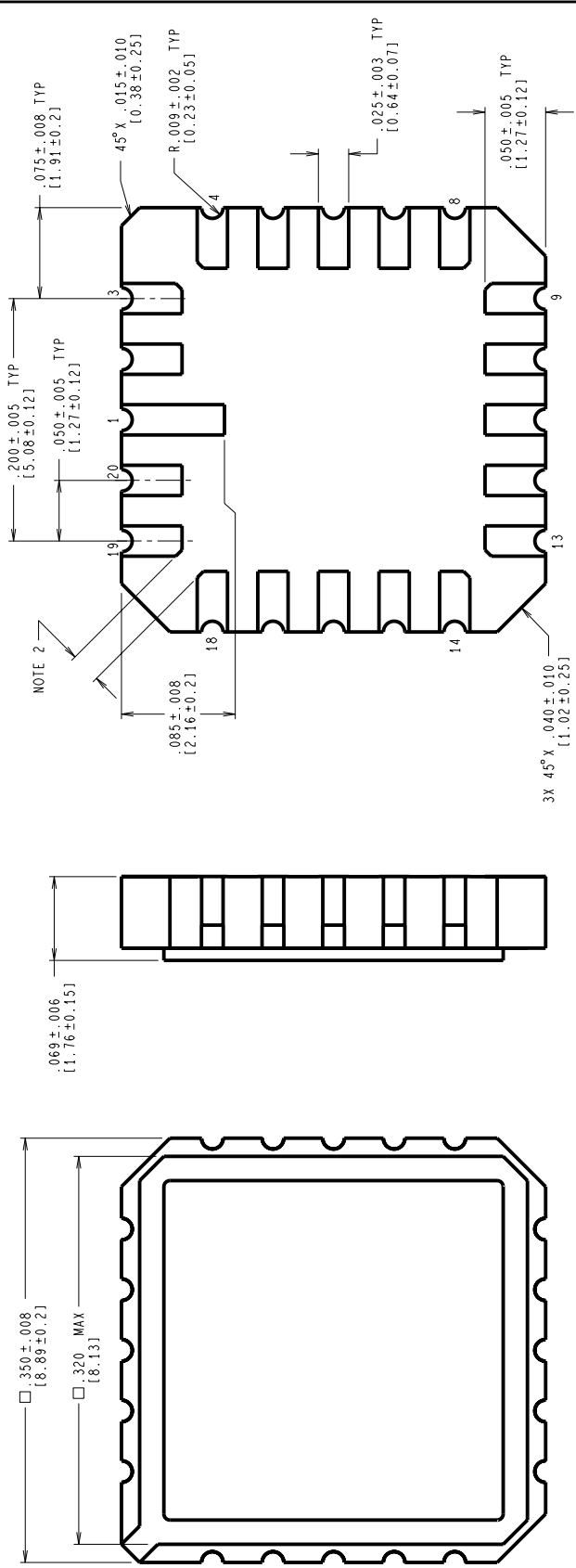

- NOTES: UNLESS OTHERWISE SPECIFIED.
- LEAD FINISH TO BE ONE OF THE FOLLOWING:
 - 50 MICRONS/12.7 MICROMETERS MINIMUM GOLD PLATING OVER 50-350 MICRONS/1.27-8.89 MICROMETERS NICKEL.
 - SOLDER DIP.
 - SOLDER THICKNESS PER LATEST REVISION OF MIL-STD-1835.
 - CORNER PADS MAY HAVE A 45° X 0.20 IN/ 0.51 mm MAXIMUM CHAMFER TO ACCOMPLISH THE 0.015 IN/ 0.38 mm DIMENSION.
 - REFERENCE JEDEC REGISTRATION MS-004, VARIATION CB, DATED 7/90.

CONTROLLING DIMENSION IS INCH
VALUES IN [] ARE MILLIMETERS

| | |
|---|----------|
| MIL/AERO CONFIGURATION CONTROL | |
| NATIONAL SEMICONDUCTOR CORPORATION 2300 Semiconductor Drive, Santa Clara, Ca. 95052-8090 | |
| APPROVALS | DATE |
| DRN: <i>Deane Gedy</i> | 02/10/94 |
| DFTG: CHK. | |
| ENGR: CHK. | |
| APPROVAL | |
| LEADLESS CHIP CARRIER, TYPE C, 20 TERMINAL | |
| SCALE | SIZE |
| N/A | C |
| DRAWING NUMBER | |
| MKT-E20A | |
| REV | E |
| DO NOT SCALE DRAWING SHEET 1 of 1 | |

| R E V I S I O N S | | | |
|-------------------|--------------------------------|----------|----------|
| LTR | DESCRIPTION | E. C. N. | DATE |
| L | REVISE PER CURRENT STD; REDRAW | 09996 | 09/15/93 |
| | | | TL/ |

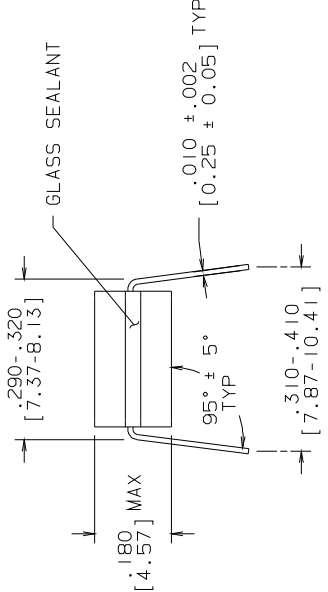
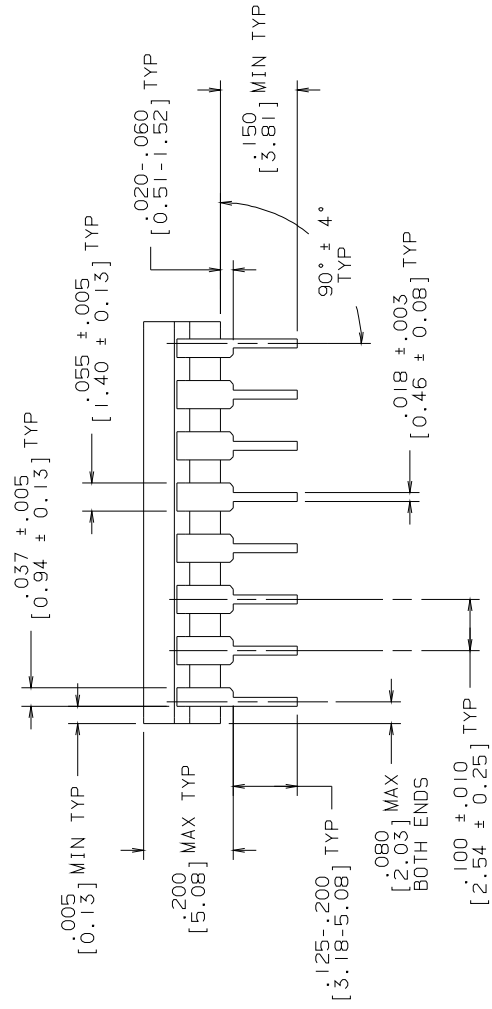
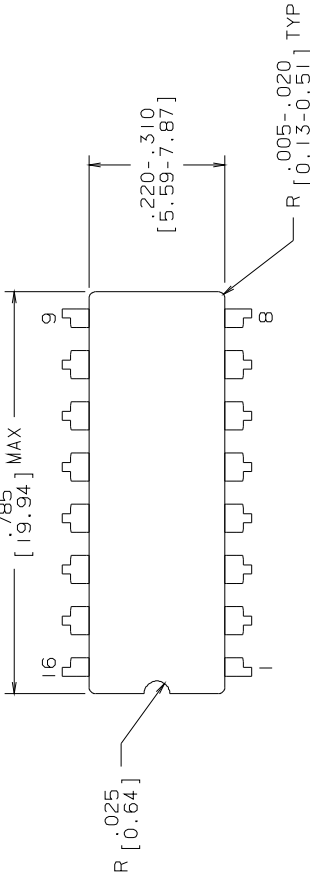

MIL/AERO CONFIGURATION CONTROL MIL-M-38510
 CONFIGURATION CONTROL CONFIGURATION CONTROL

| CONTROLLING DIMENSION: INCH | |
|-----------------------------|--------------|
| APPROVALS | DATE |
| DRAWN T. LEQUANG | 09/15/93 |
| DFTG. CHK. | |
| ENGR. CHK. | |
| APPROVAL | |
| | |
| SCALE | N/A |
| SIZE | B |
| DRAWING NUMBER | MKT-J16A |
| REV | L |
| DO NOT SCALE DRAWING | SHEET 1 OF 1 |

NATIONAL SEMICONDUCTOR CORPORATION
 2900 Semiconductor Drive, Santa Clara, CA 95052-8090

CERDIP (J),
 16 LEAD

- NOTES: UNLESS OTHERWISE SPECIFIED
- LEAD FINISH TO BE 200 MICROMETERS / 5.08 MICROMETERS MINIMUM SOLDER MEASURED AT THE CREST OF THE MAJOR FLATS.
 - JEDEC REGISTRATION MO-036, VARIATION AD, DATED 04/1981.

| REVISIONS | | | |
|-----------|-------------------------------------|--------|----------|
| LTR | DESCRIPTION | E.C.N. | DATE |
| K | REVISE AND REDRAW PER NEW STANDARD. | 10514 | 07/28/94 |
| L | .017±.002 WAS .017±.020. | 10656 | 10/21/94 |

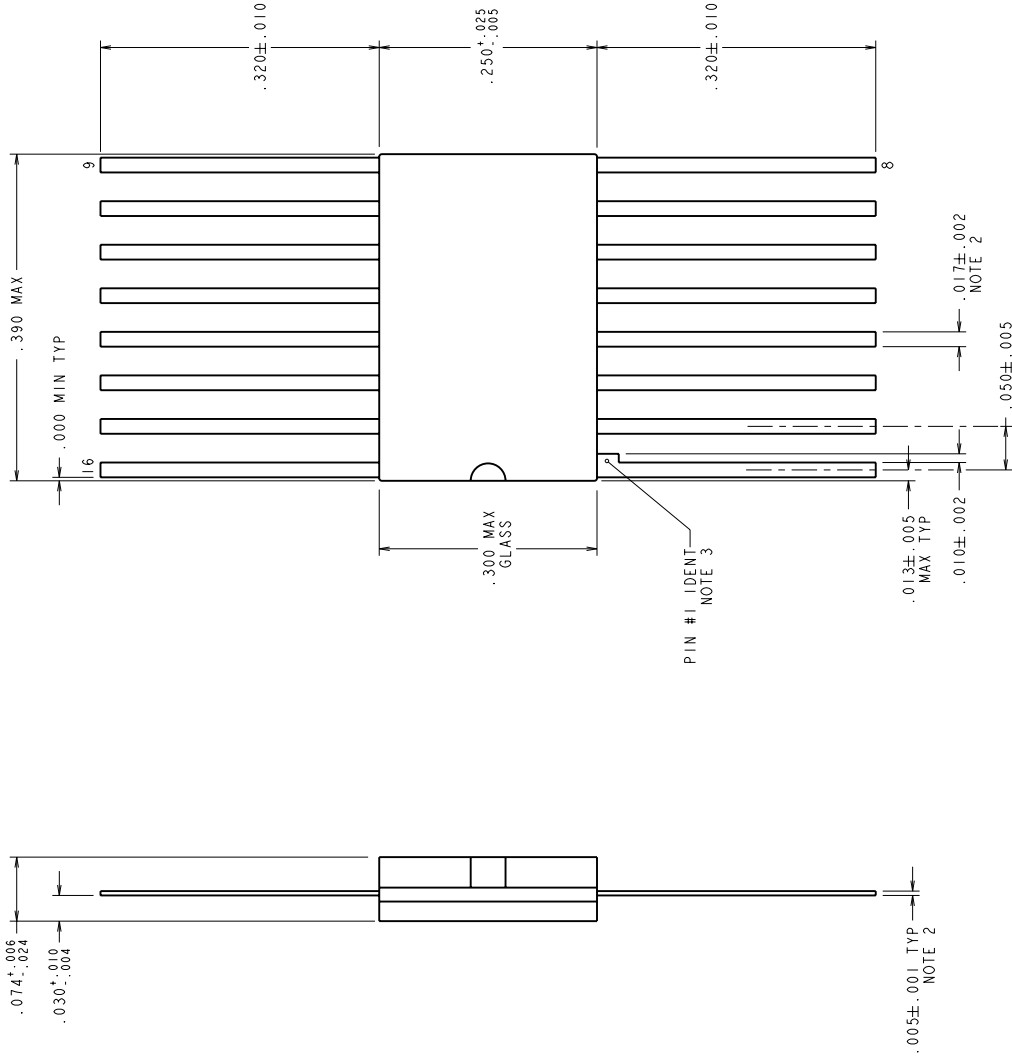

MIL/AERO
CONFIGURATION CONTROL

MIL-M-38510
CONFIGURATION CONTROL

| APPROVALS | | DATE |
|------------|--------------------|----------|
| DRWN | <i>D. F. Grady</i> | 07/28/94 |
| DTG. CHK. | | |
| ENGR. CHK. | | |

| | | | | | |
|------------|--|-------|------|----------------|-----|
| PROJECTION | | SCALE | SIZE | DRAWING NUMBER | REV |
| | | N/A | C | MKT-W16A | L |

DO NOT SCALE DRAWING SHEET 1 of 1

National Semiconductor
2800 Semiconductor dr., Santa Clara, CA 95052-8090

CERPACK, 16 LEAD

National Semiconductor was acquired by Texas Instruments.

http://www.ti.com/corp/docs/investor_relations/pr_09_23_2011_national_semiconductor.html

This file is the datasheet for the following electronic components:

5962-7802006Q2A - <http://www.ti.com/product/5962-7802006q2a?HQS=TI-null-null-dscatalog-df-pf-null-wwe>

5962-7802006QEA - <http://www.ti.com/product/5962-7802006qea?HQS=TI-null-null-dscatalog-df-pf-null-wwe>

5962-7802006QFA - <http://www.ti.com/product/5962-7802006qfa?HQS=TI-null-null-dscatalog-df-pf-null-wwe>

DS26LS32MJ-MLS - <http://www.ti.com/product/ds26ls32mj-mls?HQS=TI-null-null-dscatalog-df-pf-null-wwe>

DS26LS32MW-MLS - <http://www.ti.com/product/ds26ls32mw-mls?HQS=TI-null-null-dscatalog-df-pf-null-wwe>



LittleDiode supplies new, hard to find or obsolete electronic components and semiconductors all over the world.

With over two million different components listed you are sure to find the part you need.

Feel free to visit us today at our online store:

LittleDiode.com

Looking forward to providing you with the best possible service.