

DS26F31M

Quad High Speed Differential Line Drivers

General Description

The DS26F31 is a quad differential line driver designed for digital data transmission over balanced lines. The DS26F31 meets all the requirements of EIA Standard RS-422 and Federal Standard 1020. It is designed to provide unipolar differential drive to twisted-pair or parallel-wire transmission lines.

The DS26F31 offers improved performance due to the use of state-of-the-art L-FAST bipolar technology. The L-FAST technology allows for higher speeds and lower currents by utilizing extremely short gate delay times. Thus, the DS26F31 features lower power, extended temperature range, and improved specifications.

The circuit provides an enable and disable function common to all four drivers. The DS26F31M features TRI-STATE® outputs and logical OR-ed complementary enable inputs. The inputs are all LS compatible and are all one unit load.

The DS26F31M offers optimum performance when used with the DS26F32 Quad Differential Line Receiver.

Features

- Military temperature range
- Output skew—2.0 ns typical
- Input to output delay—10 ns
- Operation from single +5.0V supply
- 16-lead ceramic DIP Package
- Outputs won't load line when $V_{CC} = 0V$
- Output short circuit protection
- Meets the requirements of EIA standard RS-422
- High output drive capability for 100Ω terminated transmission lines

Connection and Logic Diagrams

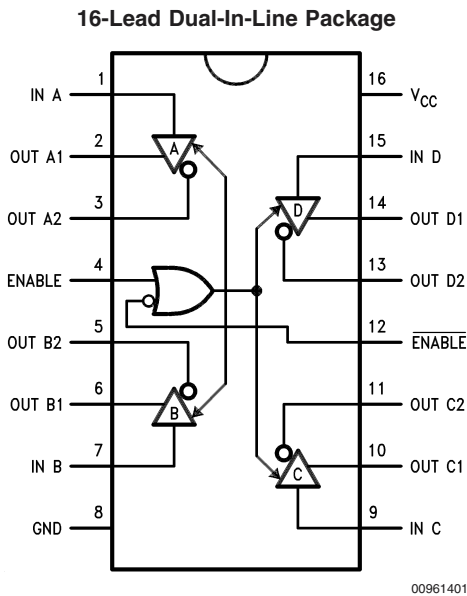

Top View

For Complete Military Product Specifications, refer to the appropriate SMD or MDS.
Order Number DS26F31ME/883, DS26F31MJ/883, or DS26F31MW/883
See NS Package Numbers E20A, J16A, or W16A

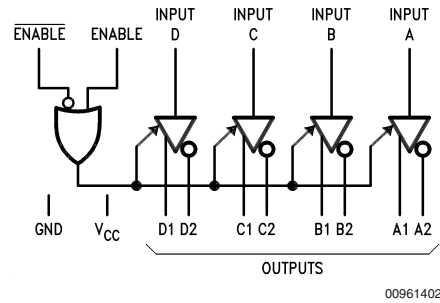
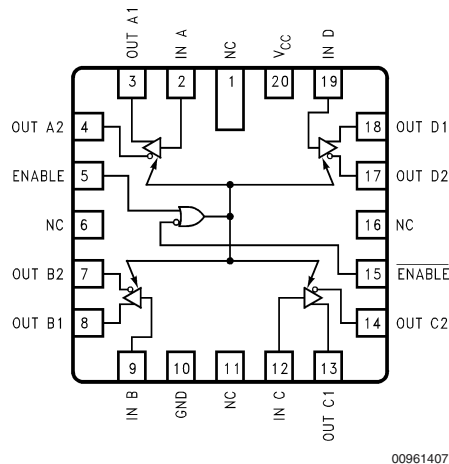

FIGURE 1. Logic Symbol

20-Lead Ceramic Leadless Chip Carrier (E)



TRI-STATE® is a registered trademark of National Semiconductor Corporation.

Absolute Maximum Ratings (Note 2)

If Military/Aerospace specified devices are required, please contact the National Semiconductor Sales Office/Distributors for availability and specifications.

Storage Temperature Range	
Ceramic DIP	–65°C to +175°C
Lead Temperature	
Ceramic DIP (Soldering, 60 sec.)	300°C
Maximum Power (Note 1) Dissipation at 25°C	
Cavity Package	1500 mW

Supply Voltage	7.0V
Input Voltage	7.0V
Output Voltage	5.5V

Operating Range

DS26F31M	
Temperature	–55°C to +125°C
Supply Voltage	4.5V to 5.5V

Note 1: Derate cavity package 10 mW/°C above 25°C.

Electrical Characteristics (Notes 3, 4)

over operating range, unless otherwise specified

Symbol	Parameter	Conditions	Min	Typ	Max	Units
V _{OH}	Output Voltage HIGH	V _{CC} = Min, I _{OH} = –20 mA	2.5	3.2		V
V _{OL}	Output Voltage LOW	V _{CC} = Min, I _{OL} = 20 mA		0.32	0.5	V
V _{IH}	Input Voltage HIGH	V _{CC} = Min	2.0			V
V _{IL}	Input Voltage LOW	V _{CC} = Max			0.8	V
I _{IL}	Input Current LOW	V _{CC} = Max, V _I = 0.4V		–0.10	–0.20	mA
I _{IH}	Input Current HIGH	V _{CC} = Max, V _I = 2.7V		0.5	20	μA
I _{IR}	Input Reverse Current	V _{CC} = Max, V _I = 7.0V		0.001	0.1	mA
I _{OZ}	Off State (High Impedance) Output Current	V _{CC} = Max		0.5	20	μA
				0.5	–20	
V _{IC}	Input Clamp Voltage	V _{CC} = Min, I _I = –18 mA		–0.8	–1.5	V
I _{OS}	Output Short Circuit	V _{CC} = Max (Note 5)	–30	–60	–150	mA
I _{CCX}	Supply Current	V _{CC} = Max, All Outputs Disabled			50	mA
I _{CC}		V _{CC} = Max, All Outputs Enabled			40	mA
t _{PLH}	Input to Output	V _{CC} = 5.0V, T _A = 25°C, Load = (Notes 6, 7)		10	15	ns
t _{PHL}	Input to Output	V _{CC} = 5.0V, T _A = 25°C, Load = (Note 6)		10	15	ns
SKEW	Output to Output	V _{CC} = 5.0V, T _A = 25°C, Load = (Notes 6, 7)		2.0	4.5	ns
t _{LZ}	Enable to Output	V _{CC} = 5.0V, T _A = 25°C, C _L = 10 pF		23	32	ns
t _{HZ}	Enable to Output	V _{CC} = 5.0V, T _A = 25°C, C _L = 10 pF		15	25	ns
t _{ZL}	Enable to Output	V _{CC} = 5.0V, T _A = 25°C, Load = (Note 6)		20	30	ns
t _{ZH}	Enable to Output	V _{CC} = 5.0V, T _A = 25°C, Load = (Note 6)		23	32	ns

Note 2: “Absolute Maximum Ratings” are those values beyond which the safety of the device cannot be guaranteed. They are not meant to imply that the devices should be operated at these limits. The tables of “Electrical Characteristics” provide conditions for actual device operation.

Note 3: Unless otherwise specified min/max limits apply across the –55°C to +125°C temperature range for the DS26F31M and across the 0°C to +70°C range for the DS26F31C. All typicals are given for V_{CC} = 5V and T_A = 25°C.

Note 4: All currents into the device pins are positive; all currents out of the device pins are negative. All voltages are referenced to ground unless otherwise specified.

Note 5: Only one output at a time should be shorted.

Note 6: C_L = 30 pF, V_I = 1.3V to V_O = 1.3V, V_{PULSE} = 0V to +3V (See AC Load Test Circuit for TRI-STATE Outputs).

Note 7: Skew is defined as the difference in propagation delays between complementary outputs at the 50% point.

Test Circuit and Timing Waveforms

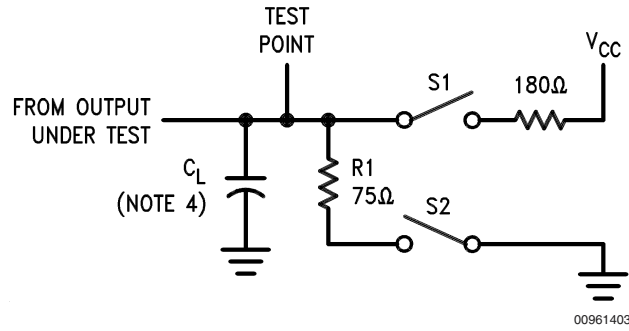

FIGURE 2. AC Load Test Circuit for TRI-STATE Outputs

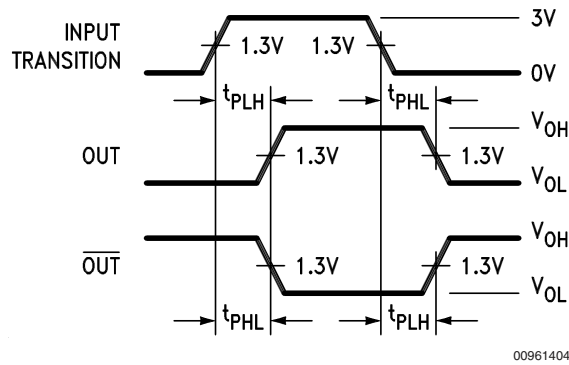

FIGURE 3. Propagation Delay (Notes 2, 4)

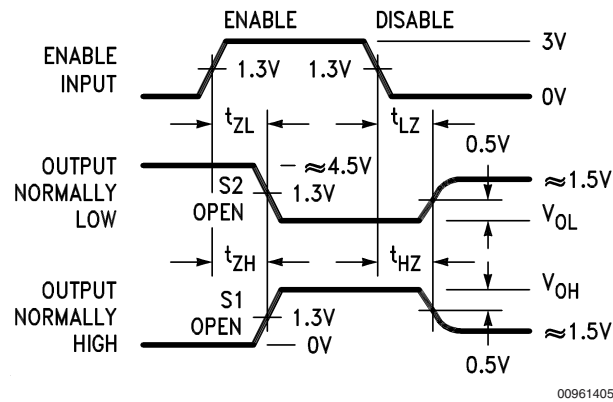

FIGURE 4. Enable and Disable Times (Notes 3, 4)

Note 8: Diagram shown for Enable Low. Switches S1 and S2 open.

Note 9: S1 and S2 of Load Circuit are closed except where shown.

Note 10: Pulse Generator for all Pulses: Rate \leq 1.0 MHz, $Z_O = 50\Omega$, $t_r \leq 6.0$ ns, $t_f \leq 6.0$ ns.

Note 11: C_L includes probe and jig capacitance.

Typical Application

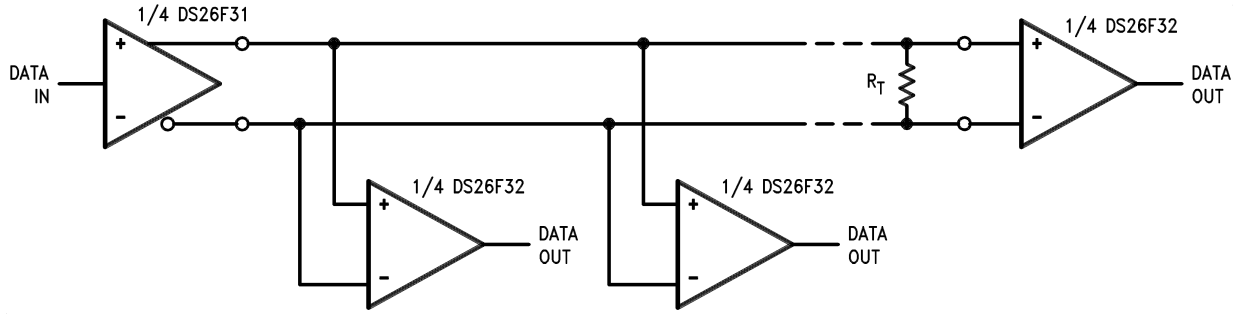

00961406

FIGURE 5. Typical Application

Physical Dimensions inches (millimeters) unless otherwise noted (Continued)

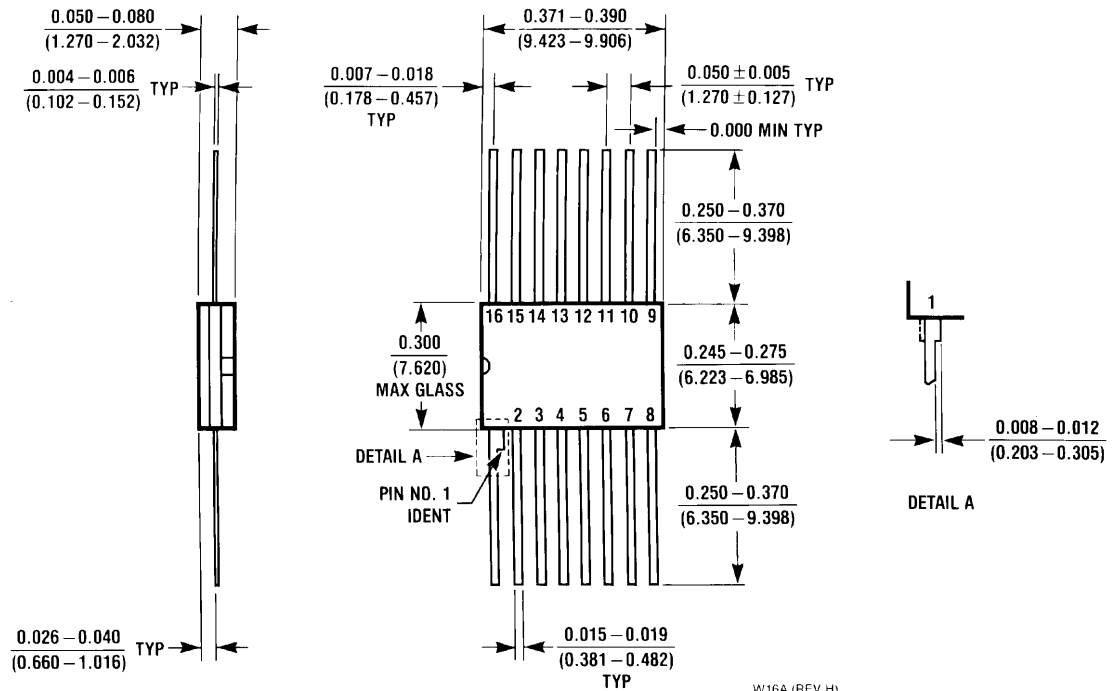

16-Lead Ceramic Flatpak (W)
DS26F31MW/883
NS Package Number W16A

W16A (REV H)

LIFE SUPPORT POLICY

NATIONAL'S PRODUCTS ARE NOT AUTHORIZED FOR USE AS CRITICAL COMPONENTS IN LIFE SUPPORT DEVICES OR SYSTEMS WITHOUT THE EXPRESS WRITTEN APPROVAL OF THE PRESIDENT AND GENERAL COUNSEL OF NATIONAL SEMICONDUCTOR CORPORATION. As used herein:

1. Life support devices or systems are devices or systems which, (a) are intended for surgical implant into the body, or (b) support or sustain life, and whose failure to perform when properly used in accordance with instructions for use provided in the labeling, can be reasonably expected to result in a significant injury to the user.
2. A critical component is any component of a life support device or system whose failure to perform can be reasonably expected to cause the failure of the life support device or system, or to affect its safety or effectiveness.

BANNED SUBSTANCE COMPLIANCE

National Semiconductor certifies that the products and packing materials meet the provisions of the Customer Products Stewardship Specification (CSP-9-111C2) and the Banned Substances and Materials of Interest Specification (CSP-9-111S2) and contain no "Banned Substances" as defined in CSP-9-111S2.



National Semiconductor
Americas Customer
Support Center
 Email: new.feedback@nsc.com
 Tel: 1-800-272-9959

National Semiconductor
Europe Customer Support Center
 Fax: +49 (0) 180-530 85 86
 Email: europe.support@nsc.com
 Deutsch Tel: +49 (0) 69 9508 6208
 English Tel: +44 (0) 870 24 0 2171
 Français Tel: +33 (0) 1 41 91 8790

National Semiconductor
Asia Pacific Customer
Support Center
 Email: ap.support@nsc.com

National Semiconductor
Japan Customer Support Center
 Fax: 81-3-5639-7507
 Email: jpn.feedback@nsc.com
 Tel: 81-3-5639-7560

www.national.com

National Semiconductor was acquired by Texas Instruments.

http://www.ti.com/corp/docs/investor_relations/pr_09_23_2011_national_semiconductor.html

This file is the datasheet for the following electronic components:

5962-7802302M2A - <http://www.ti.com/product/5962-7802302m2a?HQS=TI-null-null-dscatalog-df-pf-null-wwe>

5962-7802302MEA - <http://www.ti.com/product/5962-7802302mea?HQS=TI-null-null-dscatalog-df-pf-null-wwe>

5962-7802302MFA - <http://www.ti.com/product/5962-7802302mfa?HQS=TI-null-null-dscatalog-df-pf-null-wwe>

5962-7802302MZA - <http://www.ti.com/product/5962-7802302mza?HQS=TI-null-null-dscatalog-df-pf-null-wwe>

5962-7802302VEA - <http://www.ti.com/product/5962-7802302vea?HQS=TI-null-null-dscatalog-df-pf-null-wwe>

5962-7802302VFA - <http://www.ti.com/product/5962-7802302vfa?HQS=TI-null-null-dscatalog-df-pf-null-wwe>

DS26F31M MD8 - http://www.ti.com/product/ds26f31m_md8?HQS=TI-null-null-dscatalog-df-pf-null-wwe

5962F7802302VEA - <http://www.ti.com/product/5962f7802302vea?HQS=TI-null-null-dscatalog-df-pf-null-wwe>

5962F7802302VFA - <http://www.ti.com/product/5962f7802302vfa?HQS=TI-null-null-dscatalog-df-pf-null-wwe>

5962F7802302VZA - <http://www.ti.com/product/5962f7802302vza?HQS=TI-null-null-dscatalog-df-pf-null-wwe>



LittleDiode supplies new, hard to find or obsolete electronic components and semiconductors all over the world.

With over two million different components listed you are sure to find the part you need.

Feel free to visit us today at our online store:

LittleDiode.com

Looking forward to providing you with the best possible service.