

MNLM185B-X REV 0B0

 Original Creation Date: 08/15/95
 Last Update Date: 02/25/03
 Last Major Revision Date: 08/15/95

ADJUSTABLE MICROPOWER VOLTAGE REFERENCE
General Description

The LM185B is a micropower 3-terminal adjustable band-gap voltage reference diode. Operating from 1.24 to 5.3V and over a 10 uA to 20 mA current range, it features exceptionally low dynamic impedance and good temperature stability. On-chip trimming is used to provide tight voltage tolerance. Since the LM185B band-gap reference uses only transistors and resistors, low noise and good long-term stability result.

Careful design of the LM185B has made the device tolerant of capacitive loading, making it easy to use in almost any reference application. The wide dynamic operating range allows its use with widely varying supplies with excellent regulation.

The extremely low power drain of the LM185B makes it useful for micropower circuitry. This voltage reference can be used to make portable meters, regulators or general purpose analog circuitry with battery life approaching shelf life. Further, the wide operating current allows it to replace older references with a tighter tolerance part.

Industry Part Number

LM185B

NS Part Numbers

 LM185BE/883
 LM185BH/883

Prime Die

LM185

Processing

MIL-STD-883, Method 5004

Quality Conformance Inspection

MIL-STD-883, Method 5005

Subgrp	Description	Temp (°C)
1	Static tests at	+25
2	Static tests at	+125
3	Static tests at	-55
4	Dynamic tests at	+25
5	Dynamic tests at	+125
6	Dynamic tests at	-55
7	Functional tests at	+25
8A	Functional tests at	+125
8B	Functional tests at	-55
9	Switching tests at	+25
10	Switching tests at	+125
11	Switching tests at	-55

Features

- Adjustable from 1.24V to 5.30V.
- Operating current of 10 uA to 20 mA.
- 1% and 2% initial tolerance.
- 1 Ohm dynamic impedance.
- Low temperature coefficient.

(Absolute Maximum Ratings)

(Note 1)

Reverse Current	30mA
Forward Current	10mA
Operating Temperature Range	-55 C to +125 C
Maximum Junction Temperature	150 C
Storage Temperature	-55 C to +150 C
Lead Temperature (Soldering, 10 seconds)	300 C
Thermal Resistance	
ThetaJA	
E-Pkg (Still Air)	100 C/W
E-Pkg (500LF/Min Air flow)	73 C/W
H-Pkg (Still Air)	300 C/W
H-Pkg (500LF/Min Air flow)	139 C/W
ThetaJC	
E-Pkg	25 C/W
H-Pkg	57 C/W
Package Weight (Typical)	
E-Pkg	TBD
H-Pkg	TBD
ESD Tolerance (Note 2)	500V

Note 1: Absolute Maximum Ratings indicate limits beyond which damage to the device may occur. Operating Ratings indicate conditions for which the device is functional, but do not guarantee specific performance limits. For guaranteed specifications and test conditions, see the Electrical Characteristics. The guaranteed specifications apply only for the test conditions listed. Some performance characteristics may degrade when the device is not operated under the listed test conditions.

Note 2: Human body model, 1.5k Ohms in series with 100pF

Electrical Characteristics

DC PARAMETERS

SYMBOL	PARAMETER	CONDITIONS	NOTES	PIN-NAME	MIN	MAX	UNIT	SUB-GROUPS
Vref	Reference Voltage	Ir = 100uA			1.228	1.252	V	1
					1.215	1.255	V	2, 3
		Ir = 9uA			1.228	1.252	V	1
					1.215	1.255	V	2, 3
		Ir = 10uA			1.228	1.252	V	1
					1.215	1.255	V	2, 3
		Ir = 1mA			1.228	1.252	V	1
					1.215	1.255	V	2, 3
		Ir = 20mA			1.228	1.252	V	1
					1.215	1.255	V	2, 3
		Vr = 5.3V, Ir = 100uA			1.228	1.252	V	1
					1.215	1.255	V	2, 3
		Vr = 5.3V, Ir = 45uA			1.288	1.252	V	1
					1.215	1.255	V	2, 3
Vr = 5.3V, Ir = 50uA			1.288	1.252	V	1		
			1.215	1.255	V	2, 3		
Vr = 5.3V, Ir = 1.0mA			1.288	1.252	V	1		
			1.215	1.255	V	2, 3		
Vr = 5.3V, Ir = 20mA			1.288	1.252	V	1		
			1.215	1.255	V	2, 3		
Delta Vref/Delta Ir	Reference Voltage Change with Current	9uA ≤ Ir ≤ 1mA			1	mV	1	
		10uA ≤ Ir ≤ 1mA			1.5	mV	2, 3	
		1mA ≤ Ir ≤ 20mA			10	mV	1	
					20	mV	2, 3	
		Vr = 5.3V, 45uA ≤ Ir ≤ 1mA			1	mV	1	
		Vr = 5.3V, 50uA ≤ Ir ≤ 1mA			1.5	mV	2, 3	
Vr = 5.3V, 1mA ≤ Ir ≤ 20mA			10	mV	1			
			20	mV	2, 3			
Delta Vref/Delta Vo	Reference Voltage Change with Output Voltage	Vr = 5.3V, Ir = 100uA			3	mV	1	
					6	mV	2, 3	

Electrical Characteristics

DC PARAMETERS (Continued)

SYMBOL	PARAMETER	CONDITIONS	NOTES	PIN-NAME	MIN	MAX	UNIT	SUB-GROUPS
If	Feedback Current	Ir = 9uA				20	nA	1
		Ir = 10uA				25	nA	2, 3
		Ir = 20mA				20	nA	1
						25	nA	2, 3
		Vr = 5.3V, Ir = 45uA				20	nA	1
		Vr = 5.3V, Ir = 50uA				25	nA	2, 3
Ic	Minimum Operating Current	Vr = Vref	1		9		uA	1
			1		10		uA	2, 3
		Vr = 5.3V	1		45		uA	1
			1		50		uA	2, 3

Note 1: Functional Test.

Graphics and Diagrams

GRAPHICS#	DESCRIPTION
05886HRB2	METAL CAN (H), TO-39, 3LD, .200 DIA P.C. (B/I CKT)
06175HRB2	LCC (E), TYPE C, 20 TERMINAL (B/I CKT)
E20ARE	LCC (E), TYPE C, 20 TERMINAL(P/P DWG)
H02ARE	METAL CAN, TO-46,2LD, .100 DIA P.C. (P/P DWG)
P000188A	METAL CAN (H), TO-39, 3LD, .200 DIA P.C. (PIN OUT)
P000366B	LCC (E), 20 LEAD (PINOUT)

See attached graphics following this page.

SE
L1
LE
BO

REVISIONS			
LTR	DESCRIPTION	E.C.N.	DATE
E	REVISE AND REDRAW	10005	02/10/94 DEG/

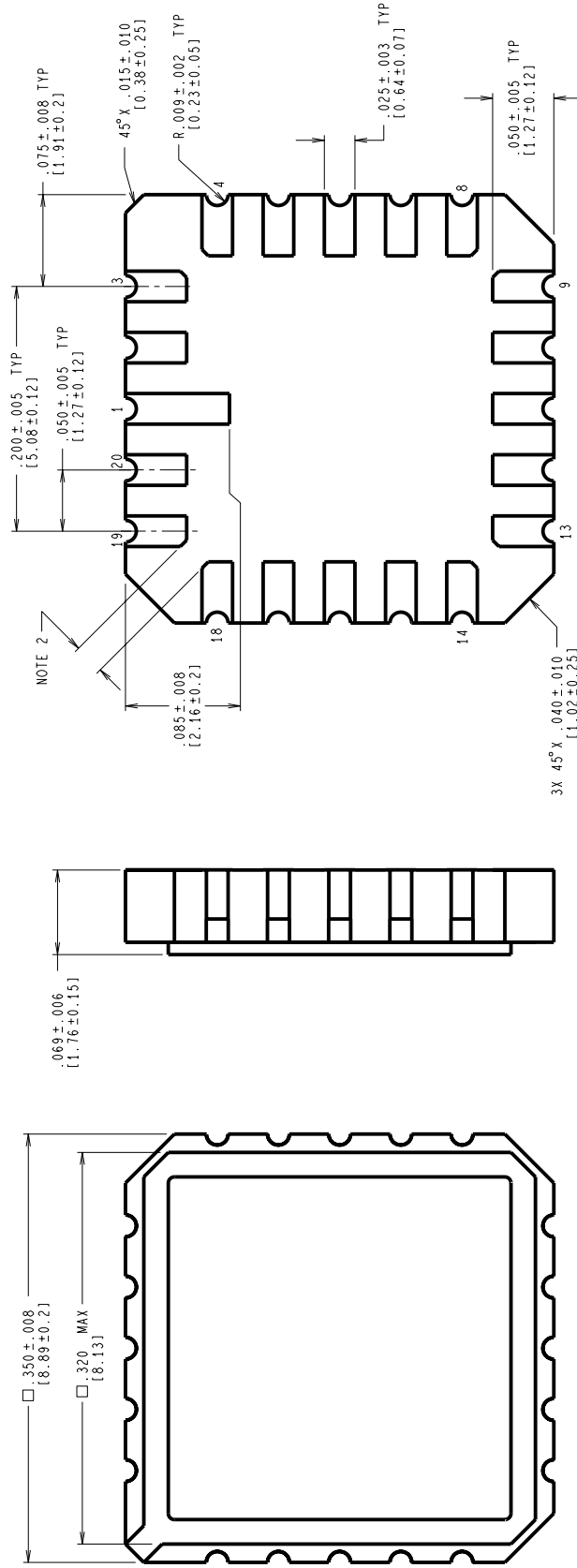

CONTROLLING DIMENSION IS INCH
VALUES IN [] ARE MILLIMETERS

NOTES: UNLESS OTHERWISE SPECIFIED.

- LEAD FINISH TO BE ONE OF THE FOLLOWING:
 - 50 MICRONS/12.7 MICROMETERS MINIMUM GOLD PLATING OVER 50-350 MICRONS/1.27-8.89 MICROMETERS NICKEL.
 - SOLDER DIP.
 - SOLDER THICKNESS PER LATEST REVISION OF MIL-STD-1835.
- CORNER PADS MAY HAVE A 45° X .020 IN/0.51mm MAXIMUM CHAMFER TO ACCOMPLISH THE .015 IN/0.38mm DIMENSION.
- REFERENCE JEDEC REGISTRATION MS-004, VARIATION CB, DATED 7/90.

MIL/AERO
CONFIGURATION CONTROL

APPROVALS		DATE
DRN	<i>Deane Gedy</i>	02/10/94
DTG - CHK.		
ENGR - CHK.		
APPROVAL		

SCALE	N/A
SIZE	C
DRAWING NUMBER	MKT-E20A
REV	E

2300 Semiconductor Drive, Santa Clara, Ca. 95052-8000	
LEADLESS CHIP CARRIER, TYPE C, 20 TERMINAL	

DO NOT SCALE DRAWING SHEET 1 of 1

REVISIONS

LTR	DESCRIPTION	E.C.N.	DATE	BY/APP'D
D	REVISE & REDRAW PER NEW STANDARD	10402	05/04/1994	TL/GY
E	UPDATE TITLE & MIL/AERO STAMP. CHANGE DWG SIZE FORMAT FROM B TO C.	12131	11/17/1998	MS/

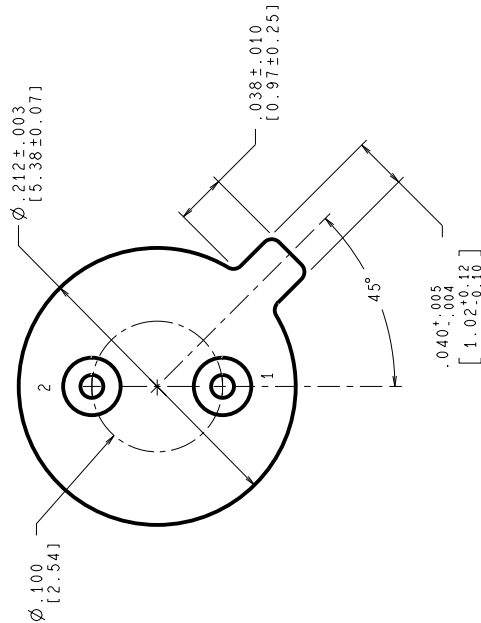
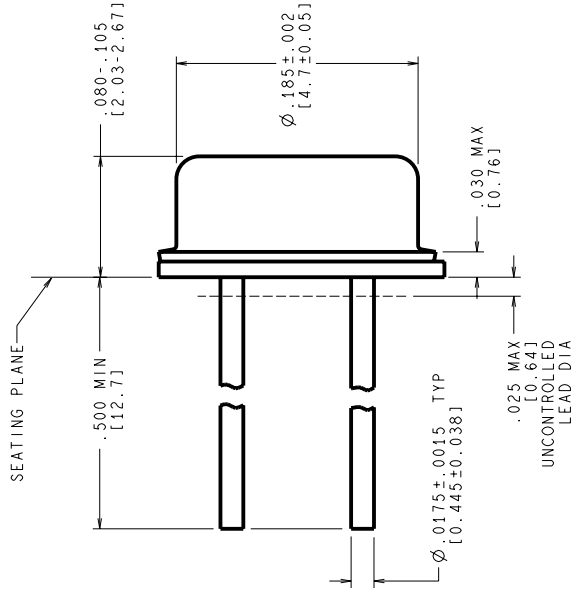

CONTROLLING DIMENSION IS INCH
VALUES IN () ARE MILLIMETERS

MIL-PRF-38535
CONFIGURATION CONTROL

NOTES: UNLESS OTHERWISE SPECIFIED

- LEADS TO BE LOCATED WITHIN .007 IN/ 0.18 mm OF THEIR TRUE POSITIONS RELATIVE TO A MAXIMUM WIDTH TAB.
- STANDARD METAL CAN TYPE: SOLID BASE.
- APPLIES TO MIL-AERO AND LINEAR PRODUCTS.
- REFERENCE JEDEC REGISTRATION TO-46, JEDEC PUBLICATION No. 95.

APPROVALS	DATE	BY
DRW: T. LEQUANG	05/04/1994	
ENGR. CHK:		
ENGR. CHK:		
PROJECTION		
SCALE	SIZE	DRAWING NUMBER
N/A	C	(SC)MKT-H02A
REV		E
DO NOT SCALE DRAWING		SHEET 1 of 1

National Semiconductor
2800 Semiconductor Dr., Santa Clara, CA 95052-8090

METAL CAN
TO-46, 2 LEAD,
.100 DIA P.C.

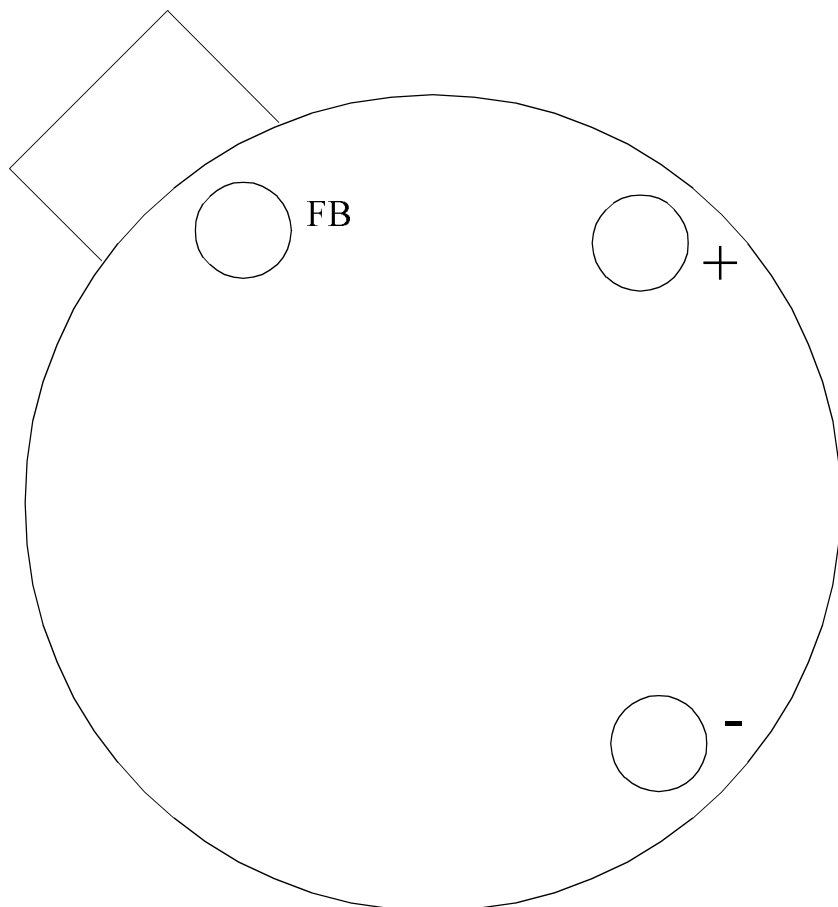

LM185H
3 - LEAD TO-46
CONNECTION DIAGRAM
BOTTOM VIEW
P000188A



National Semiconductor™
MIL/AEROSPACE OPERATIONS
2900 SEMICONDUCTOR DRIVE
SANTA CLARA, CA 95050

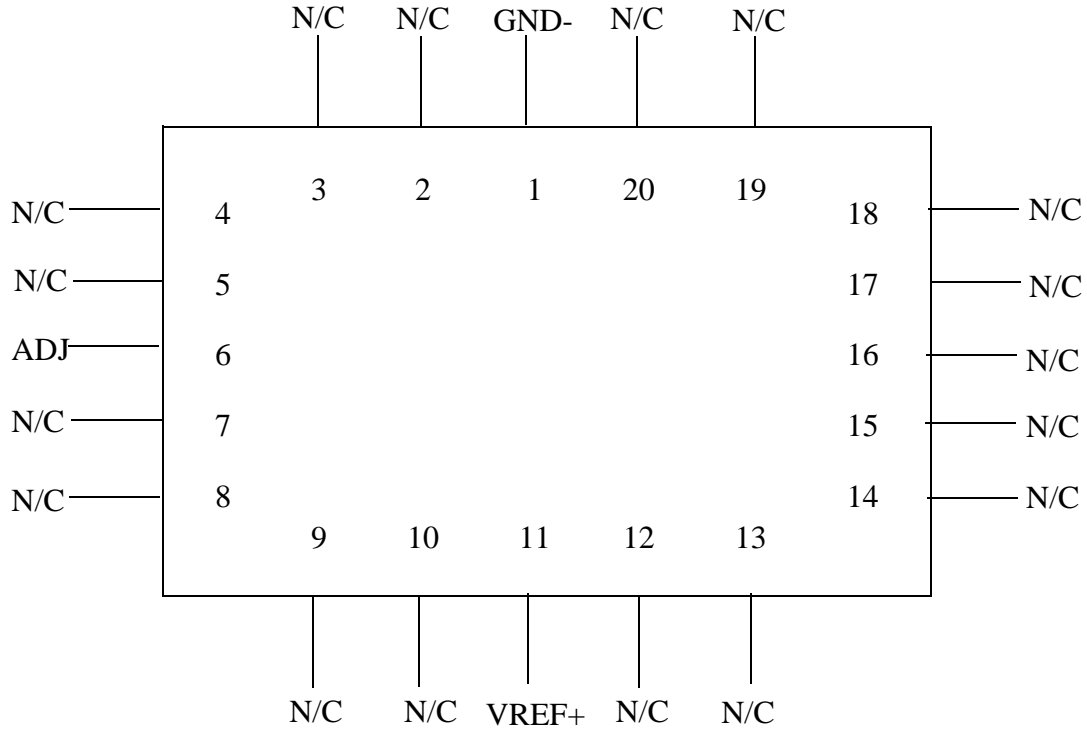

LM185E
20 - LEAD LCC
CONNECTION DIAGRAM
TOP VIEW
P000366B



National Semiconductor™

MIL/AEROSPACE OPERATIONS
 2900 SEMICONDUCTOR DRIVE
 SANTA CLARA, CA 95050

Revision History

Rev	ECN #	Rel Date	Originator	Changes
0A0	M0003059	02/25/03	Rose Malone	Archive RETS185BX, Rev. 0A. Update MDS: MNL185B-X, Rev. 0AL to MNL185B-X, Rev. 0A0, Fully Released MDS. Updated Discription, Features and Absolute section. Verified NSID.
0B0	M0004116	02/25/03	Rose Malone	Update MDS: MCLM185B-X, Rev. 0A0 to MCLM185B-X, Rev. 0B0. Added ESD Level to Absolute Maximum Ratings Section.

National Semiconductor was acquired by Texas Instruments.

http://www.ti.com/corp/docs/investor_relations/pr_09_23_2011_national_semiconductor.html

This file is the datasheet for the following electronic components:

LM185BWG-MLS - <http://www.ti.com/product/lm185bwg-mls?HQS=TI-null-null-dscatalog-df-pf-null-wwe>

LM185BH/883 - <http://www.ti.com/product/lm185bh/883?HQS=TI-null-null-dscatalog-df-pf-null-wwe>

LM185BH - <http://www.ti.com/product/lm185bh?HQS=TI-null-null-dscatalog-df-pf-null-wwe>

LM185BYH/883 - <http://www.ti.com/product/lm185byh/883?HQS=TI-null-null-dscatalog-df-pf-null-wwe>

LM185BYH-MLS - <http://www.ti.com/product/lm185byh-mls?HQS=TI-null-null-dscatalog-df-pf-null-wwe>

LM185H-2.5 - <http://www.ti.com/product/lm185h-2.5?HQS=TI-null-null-dscatalog-df-pf-null-wwe>

LM185BE/883 - <http://www.ti.com/product/lm185be/883?HQS=TI-null-null-dscatalog-df-pf-null-wwe>

5962-9091401MXA - <http://www.ti.com/product/5962-9091401mxa?HQS=TI-null-null-dscatalog-df-pf-null-wwe>

LM185BYH - <http://www.ti.com/product/lm185byh?HQS=TI-null-null-dscatalog-df-pf-null-wwe>



LittleDiode supplies new, hard to find or obsolete electronic components and semiconductors all over the world.

With over two million different components listed you are sure to find the part you need.

Feel free to visit us today at our online store:

LittleDiode.com

Looking forward to providing you with the best possible service.