

## 74ABT16244

### 16-Bit Buffer/Line Driver with 3-STATE Outputs

#### General Description

The ABT16244 contains sixteen non-inverting buffers with 3-STATE outputs designed to be employed as a memory and address driver, clock driver, or bus oriented transmitter/receiver. The device is nibble controlled. Individual 3-STATE control inputs can be shorted together for 8-bit or 16-bit operation.

#### Features

- Separate control logic for each nibble
- 16-bit version of the ABT244
- Outputs sink capability of 64 mA, source capability of 32 mA
- Guaranteed output skew
- Guaranteed multiple output switching specifications
- Output switching specified for both 50 pF and 250 pF loads
- Guaranteed simultaneous switching noise level and dynamic threshold performance
- Guaranteed latchup protection
- High impedance glitch free bus loading during entire power up and power down cycle
- Non-destructive hot insertion capability

#### Ordering Code:

Order Number	Package Number	Package Description
74ABT16244CSSC	MS48A	48-Lead Small Shrink Outline Package (SSOP), JEDEC MO-118, 0.300" Wide
74ABT16244CMD	MTD48	48-Lead Thin Shrink Small Outline Package (TSSOP), JEDEC MO-153, 6.1mm Wide

Devices are also available in Tape and Reel. Specify by appending the suffix letter "X" to the ordering code.

#### Logic Symbol

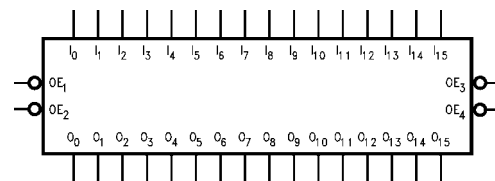

#### Connection Diagram

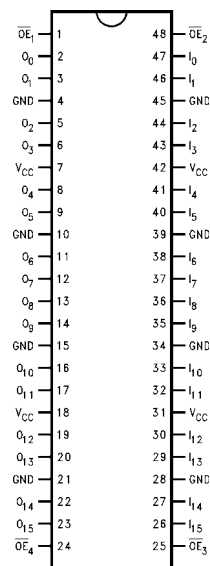

#### Pin Descriptions

Pin Names	Description
$\overline{OE}_n$	Output Enable Inputs (Active LOW)
$I_0-I_{15}$	Inputs
$O_0-O_{15}$	Outputs

### Truth Tables

Inputs		Outputs
$\overline{OE}_1$	I <sub>0-13</sub>	O <sub>0-03</sub>
L	L	L
L	H	H
H	X	Z

Inputs		Outputs
$\overline{OE}_2$	I <sub>4-17</sub>	O <sub>4-07</sub>
L	L	L
L	H	H
H	X	Z

Inputs		Outputs
$\overline{OE}_3$	I <sub>8-11</sub>	O <sub>8-011</sub>
L	L	L
L	H	H
H	X	Z

Inputs		Outputs
$\overline{OE}_4$	I <sub>12-15</sub>	O <sub>12-015</sub>
L	L	L
L	H	H
H	X	Z

H = HIGH Voltage Level  
 L = LOW Voltage Level  
 X = Immaterial  
 Z = High Impedance

### Functional Description

The ABT16244 contains sixteen non-inverting buffers with 3-STATE outputs. The device is nibble (4 bits) controlled with each nibble functioning identically, but independent of the other. The control pins can be shorted together to obtain full 16-bit operation.

### Logic Diagram

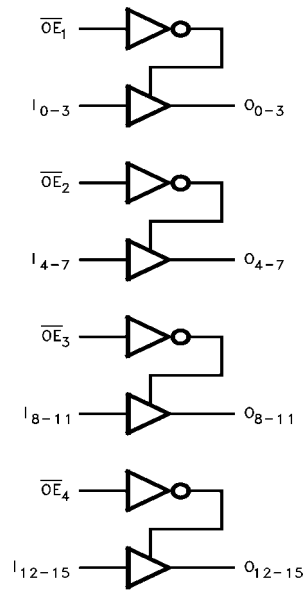

**Absolute Maximum Ratings**(Note 1)

Storage Temperature	-65°C to +150°C
Ambient Temperature under Bias	-55°C to +125°C
Junction Temperature under Bias	-55°C to +150°C
V <sub>CC</sub> Pin Potential to Ground Pin	-0.5V to +7.0V
Input Voltage (Note 2)	-0.5V to +7.0V
Input Current (Note 2)	-30 mA to +5.0 mA
Voltage Applied to Any Output in the Disabled or Power-Off State	-0.5V to 5.5V
in the HIGH State	-0.5V to V <sub>CC</sub>
Current Applied to Output in LOW State (Max)	twice the rated I <sub>OL</sub> (mA)
DC Latchup Source Current	-500 mA
Over Voltage Latchup (I/O)	10V

**Recommended Operating Conditions**

Free Air Ambient Temperature	-40°C to +85°C
Supply Voltage	+4.5V to +5.5V
Minimum Input Edge Rate ( $\Delta V/\Delta t$ )	
Data Input	50 mV/ns
Enable Input	20 mV/ns

**Note 1:** Absolute maximum ratings are values beyond which the device may be damaged or have its useful life impaired. Functional operation under these conditions is not implied.

**Note 2:** Either voltage limit or current limit is sufficient to protect inputs.

**DC Electrical Characteristics**

Symbol	Parameter	Min	Typ	Max	Units	V <sub>CC</sub>	Conditions
V <sub>IH</sub>	Input HIGH Voltage	2.0			V		Recognized HIGH Signal
V <sub>IL</sub>	Input LOW Voltage			0.8	V		Recognized LOW Signal
V <sub>CD</sub>	Input Clamp Diode Voltage			-1.2	V	Min	I <sub>IN</sub> = -18 mA
V <sub>OH</sub>	Output HIGH Voltage	2.5			V	Min	I <sub>OH</sub> = -3 mA
		2.0			V	Min	I <sub>OH</sub> = -32 mA
V <sub>OL</sub>	Output LOW Voltage			0.55	V	Min	I <sub>OL</sub> = 64 mA
I <sub>IH</sub>	Input HIGH Current			1	μA	Max	V <sub>IN</sub> = 2.7V (Note 3) V <sub>IN</sub> = V <sub>CC</sub>
				1	μA		
I <sub>BVI</sub>	Input HIGH Current Breakdown Test			7	μA	Max	V <sub>IN</sub> = 7.0V
I <sub>IL</sub>	Input LOW Current			-1	μA	Max	V <sub>IN</sub> = 0.5V (Note 3) V <sub>IN</sub> = 0.0V
				-1	μA		
V <sub>ID</sub>	Input Leakage Test	4.75			V	0.0	I <sub>ID</sub> = 1.9 μA All Other Pins Grounded
I <sub>OZH</sub>	Output Leakage Current			10	μA	0 - 5.5V	V <sub>OUT</sub> = 2.7V; $\overline{OE}_n = 2.0V$
I <sub>OZL</sub>	Output Leakage Current			-10	μA	0 - 5.5V	V <sub>OUT</sub> = 0.5V; $\overline{OE}_n = 2.0V$
I <sub>OS</sub>	Output Short-Circuit Current	-100		-275	mA	Max	V <sub>OUT</sub> = 0.0V
I <sub>CEx</sub>	Output HIGH Leakage Current			50	μA	Max	V <sub>OUT</sub> = V <sub>CC</sub>
I <sub>ZZ</sub>	Bus Drainage Test			100	μA	0.0	V <sub>OUT</sub> = 5.5V All Other Pins GND
I <sub>CCH</sub>	Power Supply Current			2.0	mA	Max	All Outputs HIGH
I <sub>CCL</sub>	Power Supply Current			60	mA	Max	All Outputs LOW
I <sub>CCZ</sub>	Power Supply Current			2.0	mA	Max	$\overline{OE}_n = V_{CC}$ All Others at V <sub>CC</sub> or GND
I <sub>CCT</sub>	Additional I <sub>CC</sub> /Input			2.5	mA		V <sub>I</sub> = V <sub>CC</sub> - 2.1V
	Outputs Enabled			2.5	mA	Max	Enable Input V <sub>I</sub> = V <sub>CC</sub> - 2.1V
	Outputs 3-STATE			2.5	mA		Data Input V <sub>I</sub> = V <sub>CC</sub> - 2.1V
	Outputs 3-STATE			50	μA		All Others at V <sub>CC</sub> or GND
I <sub>CCD</sub>	Dynamic I <sub>CC</sub>				mA/ MHz	Max	Outputs Open, $\overline{OE}_n = GND$ One Bit Toggling, 50% Duty Cycle
	(Note 3)			0.1			

**Note 3:** Guaranteed but not tested.

## DC Electrical Characteristics

Symbol	Parameter	Min	Typ	Max	Units	V <sub>CC</sub>	Conditions C <sub>L</sub> = 50 pF, R <sub>L</sub> = 500Ω
V <sub>OLP</sub>	Quiet Output Maximum Dynamic V <sub>OL</sub>		0.4	0.7	V	5.0	T <sub>A</sub> = 25°C (Note 4)
V <sub>OLV</sub>	Quiet Output Minimum Dynamic V <sub>OL</sub>	-1.3	-1.0		V	5.0	T <sub>A</sub> = 25°C (Note 4)
V <sub>OHV</sub>	Minimum HIGH Level Dynamic Output Voltage	2.7	3.0		V	5.0	T <sub>A</sub> = 25°C (Note 5)
V <sub>IHD</sub>	Minimum HIGH Level Dynamic Input Voltage	2.0	1.4		V	5.0	T <sub>A</sub> = 25°C (Note 6)
V <sub>ILD</sub>	Maximum LOW Level Dynamic Input Voltage		1.2	0.8	V	5.0	T <sub>A</sub> = 25°C (Note 6)

**Note 4:** Max number of outputs defined as (n). n-1 data inputs are driven 0V to 3V. One output at LOW. Guaranteed, but not tested.

**Note 5:** Max number of outputs defined as (n). n – 1 data inputs are driven 0V to 3V. One output HIGH. Guaranteed, but not tested.

**Note 6:** Max number of data inputs (n) switching. n-1 inputs switching 0V to 3V. Input-under-test switching: 3V to threshold (V<sub>ILD</sub>), 0V to threshold (V<sub>IHD</sub>). Guaranteed, but not tested.

## AC Electrical Characteristics

Symbol	Parameter	T <sub>A</sub> = +25°C V <sub>CC</sub> = +5V C <sub>L</sub> = 50 pF			T <sub>A</sub> = -40°C to +85°C V <sub>CC</sub> = 4.5V–5.5V C <sub>L</sub> = 50 pF		Units
		Min	Typ	Max	Min	Max	
t <sub>PLH</sub>	Propagation Delay Data to Outputs	1.0	2.3	3.9	1.0	3.9	ns
t <sub>PHL</sub>		1.0	2.7	3.9	1.0	3.9	
t <sub>PZH</sub>	Output Enable Time	1.5	3.5	6.3	1.5	6.3	ns
t <sub>PZL</sub>		1.5	3.5	6.3	1.5	6.3	
t <sub>PHZ</sub>	Output Disable Time	1.0	4.2	6.7	1.0	6.7	ns
t <sub>PLZ</sub>		1.0	3.2	6.7	1.0	6.7	

## Extended AC Electrical Characteristics

Symbol	Parameter	-40°C to +85°C V <sub>CC</sub> = 4.5V–5.5V C <sub>L</sub> = 50 pF 16 Outputs Switching (Note 7)			T <sub>A</sub> = -40°C to +85°C V <sub>CC</sub> = 4.5V–5.5V C <sub>L</sub> = 250 pF 1 Output Switching (Note 8)		T <sub>A</sub> = -40°C to +85°C V <sub>CC</sub> = 4.5V–5.5V C <sub>L</sub> = 250 pF 16 Outputs Switching (Note 9)		Units
		Min	Typ	Max	Min	Max	Min	Max	
f <sub>TOGGLE</sub>	Max Toggle Frequency		100						MHz
t <sub>PLH</sub>	Propagation Delay Data to Outputs	1.5		5.0	1.5	6.0	2.5	8.0	ns
t <sub>PHL</sub>		1.5		5.3	1.5	6.0	2.5	8.0	
t <sub>PZH</sub>	Output Enable Time	1.5		6.5	2.5	7.8	2.5	9.5	ns
t <sub>PZL</sub>		1.5		6.5	2.5	7.8	2.5	8.5	
t <sub>PHZ</sub>	Output Disable Time	1.0		6.7					ns
t <sub>PLZ</sub>		1.0		6.7		(Note 10)		(Note 10)	

**Note 7:** This specification is guaranteed but not tested. The limits apply to propagation delays for all paths described switching in phase (i.e., all LOW-to-HIGH, HIGH-to-LOW, etc.).

**Note 8:** This specification is guaranteed but not tested. The limits represent propagation delay with 250 pF load capacitors in place of the 50 pF load capacitors in the standard AC load. This specification pertains to single output switching only.

**Note 9:** This specification is guaranteed but not tested. The limits represent propagation delays for all paths described switching in phase (i.e., all LOW-to-HIGH, HIGH-to-LOW, etc.) with 250 pF load capacitors in place of the 50 pF load capacitors in the standard AC load.

**Note 10:** The 3-STATE delay times are dominated by the RC network (500Ω, 250 pF) on the output and have been excluded from the datasheet.

<b>Skew</b>				
Symbol	Parameter	$T_A = -40^\circ\text{C to }+85^\circ\text{C}$ $V_{CC} = 4.5\text{V}-5.5\text{V}$ $C_L = 50\text{ pF}$ 16 Outputs Switching (Note 11)	$T_A = -40^\circ\text{C to }+85^\circ\text{C}$ $V_{CC} = 4.5\text{V}-5.5\text{V}$ $C_L = 250\text{ pF}$ 16 Outputs Switching (Note 12)	Units
		Max	Max	
$t_{OSHL}$ (Note 13)	Pin to Pin Skew HL Transitions	1.0	1.5	ns
$t_{OSLH}$ (Note 13)	Pin to Pin Skew LH Transitions	1.0	1.5	ns
$t_{PS}$ (Note 14)	Duty Cycle LH-HL Skew	1.5	1.5	ns
$t_{OST}$ (Note 13)	Pin to Pin Skew LH/HL Transitions	1.7	2.0	ns
$t_{PV}$ (Note 15)	Device to Device Skew LH/HL Transitions	2.0	2.5	ns
<p><b>Note 11:</b> This specification is guaranteed but not tested. The limits apply to propagation delays for all paths described switching in phase (i.e., all LOW-to-HIGH, HIGH-to-LOW, etc.)</p> <p><b>Note 12:</b> These specifications guaranteed but not tested. The limits represent propagation delays with 250 pF load capacitors in place of the 50 pF load capacitors in the standard AC load.</p> <p><b>Note 13:</b> Skew is defined as the absolute value of the difference between the actual propagation delays for any two separate outputs of the same device. The specification applies to any outputs switching HIGH to LOW (<math>t_{OSHL}</math>), LOW-to-HIGH (<math>t_{OSLH}</math>), or any combination switching LOW-to-HIGH and/or HIGH-to-LOW (<math>t_{OST}</math>). The specification is guaranteed but not tested.</p> <p><b>Note 14:</b> This describes the difference between the delay of the LOW-to-HIGH and the HIGH-to-LOW transition on the same pin. It is measured across all the outputs (drivers) on the same chip, the worst (largest delta) number is the guaranteed specification. This specification is guaranteed but not tested.</p> <p><b>Note 15:</b> Propagation delay variation for a given set of conditions (i.e., temperature and <math>V_{CC}</math>) from device to device. This specification is guaranteed but not tested.</p>				
<b>Capacitance</b>				
Symbol	Parameter	Typ	Units	Conditions $T_A = 25^\circ\text{C}$
$C_{IN}$	Input Capacitance	5.0	pF	$V_{CC} = 5.0\text{V}$
$C_{OUT}$ (Note 16)	Output Capacitance	9.0	pF	$V_{CC} = 5.0\text{V}$
<p><b>Note 16:</b> <math>C_{OUT}</math> is measured at frequency <math>f = 1\text{ MHz}</math>; per MIL STD-883, Method 3012.</p>				

### AC Loading

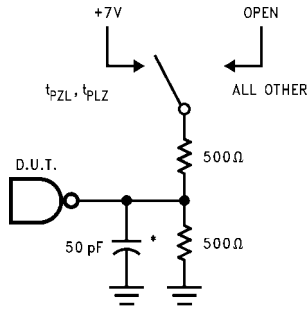

\*Includes jig and probe capacitance

FIGURE 1. Standard AC Test Load

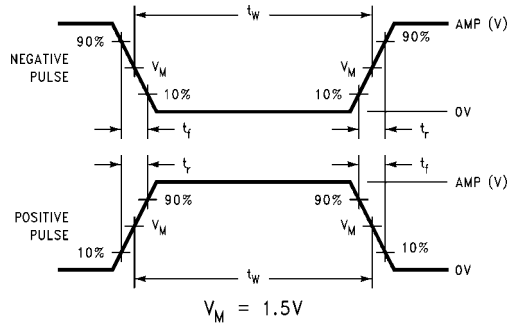

FIGURE 2. Test Input Pulse Requirements

Amplitude	Rep Rate	$t_w$	$t_r$	$t_f$
3.0V	1 MHz	500 ns	2.5 ns	2.5 ns

FIGURE 3. Test Input Signal Requirements

### AC Waveforms

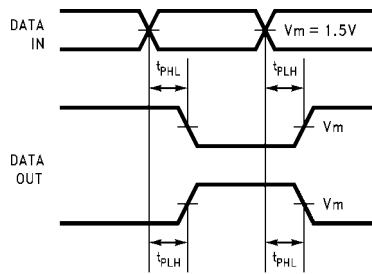

FIGURE 4. Propagation Delay Waveforms for Inverting and Non-Inverting Functions

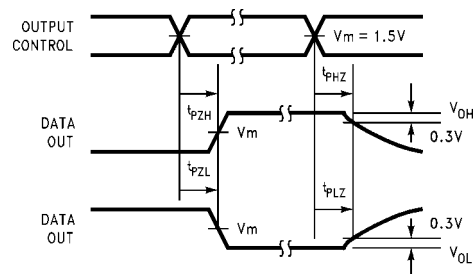

FIGURE 6. 3-STATE Output HIGH and LOW Enable and Disable Times

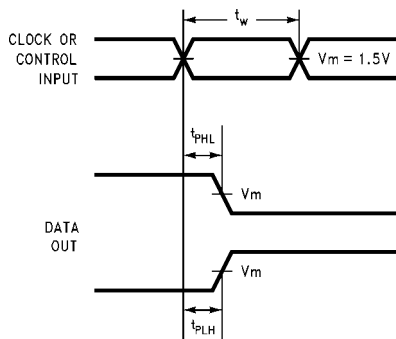

FIGURE 5. Propagation Delay, Pulse Width Waveforms

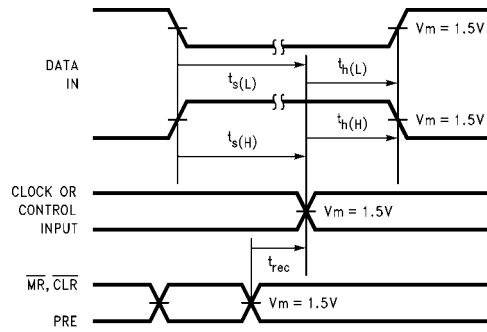
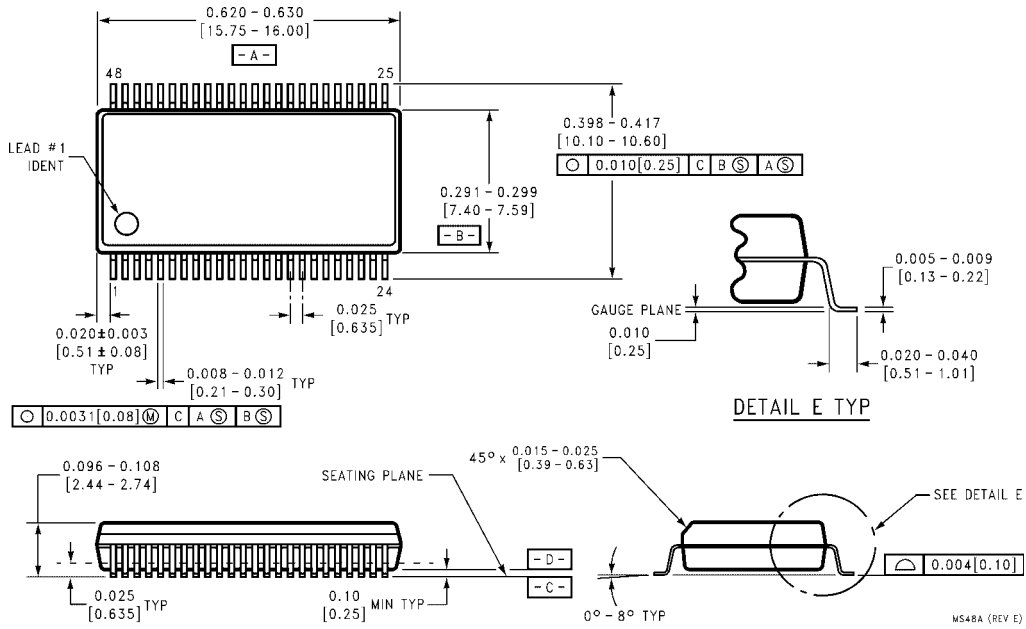

FIGURE 7. Setup Time, Hold Time and Recovery Time Waveforms

**Physical Dimensions** inches (millimeters) unless otherwise noted



**48-Lead Small Shrink Outline Package (SSOP), JEDEC MO-118, 0.300" Wide  
Package Number MS48A**

MS48A (REV E)

**Physical Dimensions** inches (millimeters) unless otherwise noted (Continued)

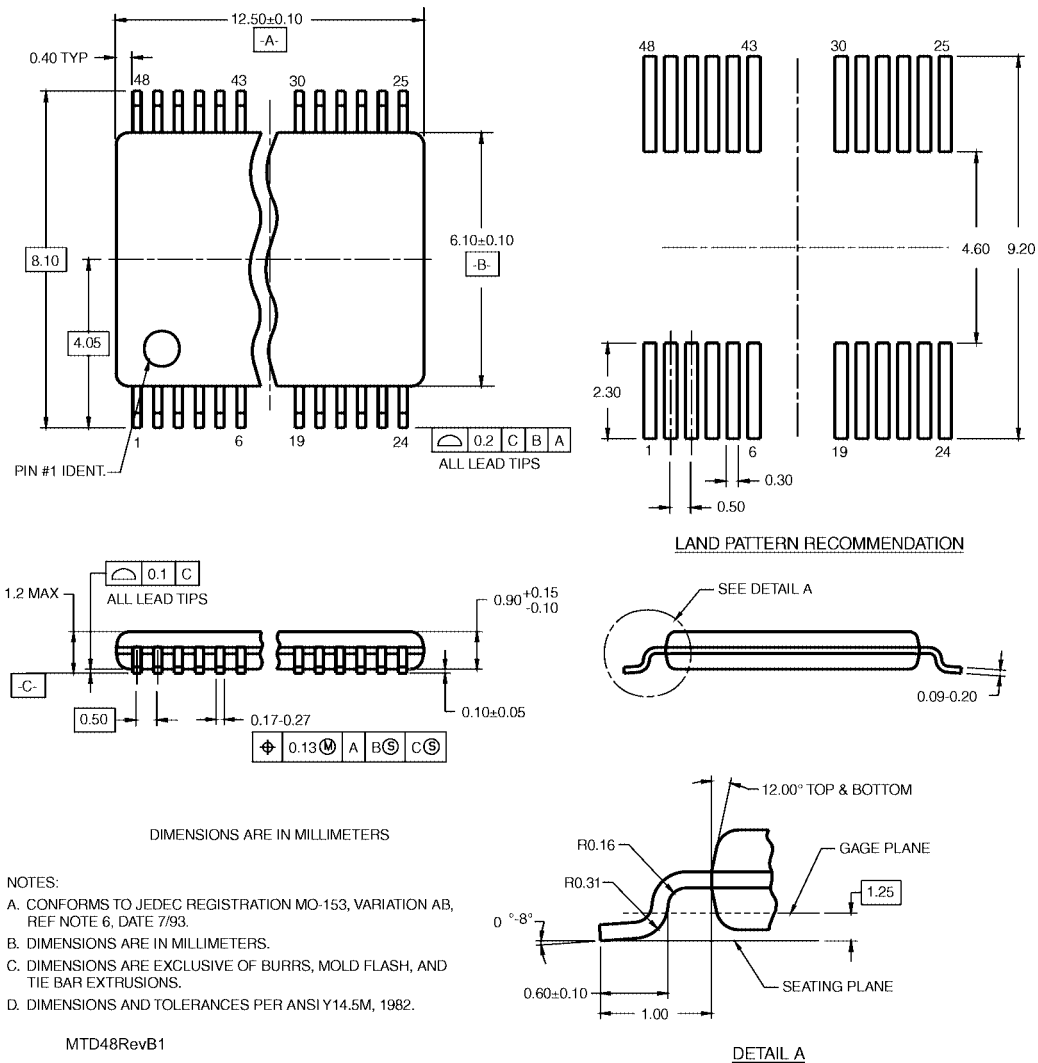

Fairchild does not assume any responsibility for use of any circuitry described, no circuit patent licenses are implied and Fairchild reserves the right at any time without notice to change said circuitry and specifications.

**LIFE SUPPORT POLICY**

FAIRCHILD'S PRODUCTS ARE NOT AUTHORIZED FOR USE AS CRITICAL COMPONENTS IN LIFE SUPPORT DEVICES OR SYSTEMS WITHOUT THE EXPRESS WRITTEN APPROVAL OF THE PRESIDENT OF FAIRCHILD SEMICONDUCTOR CORPORATION. As used herein:

1. Life support devices or systems are devices or systems which, (a) are intended for surgical implant into the body, or (b) support or sustain life, and (c) whose failure to perform when properly used in accordance with instructions for use provided in the labeling, can be reasonably expected to result in a significant injury to the user.
2. A critical component in any component of a life support device or system whose failure to perform can be reasonably expected to cause the failure of the life support device or system, or to affect its safety or effectiveness.

[www.fairchildsemi.com](http://www.fairchildsemi.com)



LittleDiode supplies new, hard to find or obsolete electronic components and semiconductors all over the world.

With over two million different components listed you are sure to find the part you need.

Feel free to visit us today at our online store:

[LittleDiode.com](http://LittleDiode.com)

Looking forward to providing you with the best possible service.