

DATA SHEET

74ABT16373B

74ABTH16373B

16-bit transparent latch (3-State)

Product specification
Supersedes data of 1995 Aug 03
IC23 Data Handbook

1998 Feb 27

16-bit transparent latch (3-State)

74ABT16373B 74ABTH16373B

FEATURES

- 16-bit transparent latch
- Multiple V_{CC} and GND pins minimize switching noise
- Power-up 3-State
- Live insertion/extraction permitted
- Power-up reset
- 3-State output buffers
- 74ABTH16373B incorporates bus-hold data inputs which eliminate the need for external pull-up resistors to hold unused inputs
- Output capability: +64mA/−32mA
- I_{CCL} −19 mA maximum
- Latch-up protection exceeds 500mA per JEDEC Std 17
- ESD protection exceeds 2000V per MIL STD 883 Method 3015 and 200V per Machine Model

DESCRIPTION

The 74ABT16373B high-performance BiCMOS device combines low static and dynamic power dissipation with high speed and high output drive.

The 74ABT16373B device is a dual octal transparent latch coupled to two sets of eight 3-State output buffers. The two sections of the device are controlled independently by Enable (nE) and Output Enable (nOE) control gates.

The data on each set of D inputs are transferred to the latch outputs when the Latch Enable (nE) input is High. The latch remains transparent to the data inputs while nE is High, and stores the data that is present one setup time before the High-to-Low enable transition.

The 3-State output buffers are designed to drive heavily loaded 3-State buses, MOS memories, or MOS microprocessors. Each active-Low Output Enable (nOE) controls eight 3-State buffers independent of the latch operation.

When nOE is Low, the latched or transparent data appears at the outputs. When nOE is High, the outputs are in the High-impedance "OFF" state, which means they will neither drive nor load the bus.

Two options are available, 74ABT16373B which does not have the bus-hold feature and 74ABTH16373B which incorporates the bus-hold feature.

PIN CONFIGURATION

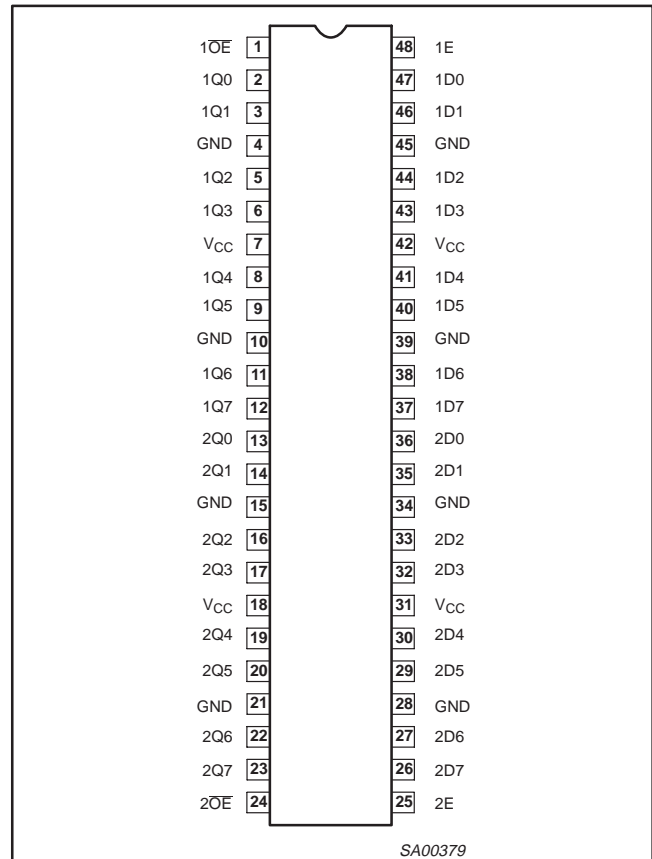

QUICK REFERENCE DATA

SYMBOL	PARAMETER	CONDITIONS $T_{amb} = 25^{\circ}\text{C}; \text{GND} = 0\text{V}$	TYPICAL	UNIT
t_{PLH} t_{PHL}	Propagation delay Dn to Qn	$C_L = 50\text{pF}; V_{CC} = 5\text{V}$	2.5 2.0	ns
C_{IN}	Input capacitance	$V_I = 0\text{V}$ or V_{CC}	4	pF
C_{OUT}	Output capacitance	$V_O = 0\text{V}$ or V_{CC} ; 3-State	7	pF
I_{CCZ}	Quiescent supply current	Outputs disabled; $V_{CC} = 5.5\text{V}$	500	μA
I_{CCL}		Outputs low; $V_{CC} = 5.5\text{V}$	8	mA

ORDERING INFORMATION

PACKAGES	TEMPERATURE RANGE	OUTSIDE NORTH AMERICA	NORTH AMERICA	DWG NUMBER
48-Pin SSOP type III	−40°C to +85°C	74ABT16373B DL	BT16373B DL	SOT370-1
48-Pin TSSOP type II	−40°C to +85°C	74ABT16373B DGG	BT16373B DGG	SOT362-1
48-Pin SSOP type III	−40°C to +85°C	74ABTH16373B DL	BH16373B DL	SOT370-1
48-Pin TSSOP type II	−40°C to +85°C	74ABTH16373B DGG	BH16373B DGG	SOT362-1

16-bit transparent latch (3-State)

74ABT16373B
74ABTH16373B

PIN DESCRIPTION

PIN NUMBER	SYMBOL	FUNCTION
47, 46, 44, 43, 41, 40, 38, 37, 36, 35, 33, 32, 30, 29, 27, 26	1D0 – 1D7 2D0 – 2D7	Data inputs
2, 3, 5, 6, 8, 9, 11, 12, 13, 14, 16, 17, 19, 20, 22, 23	1Q0 – 1Q7 2Q0 – 2Q7	Data outputs
1, 24	1OE, 2OE	Output enable inputs (active-Low)
48, 25	1E, 2E	Enable inputs (active-High)
4, 10, 15, 21, 28, 34, 39, 45	GND	Ground (0V)
7, 18, 31, 42	V _{CC}	Positive supply voltage

LOGIC SYMBOL (IEEE/IEC)

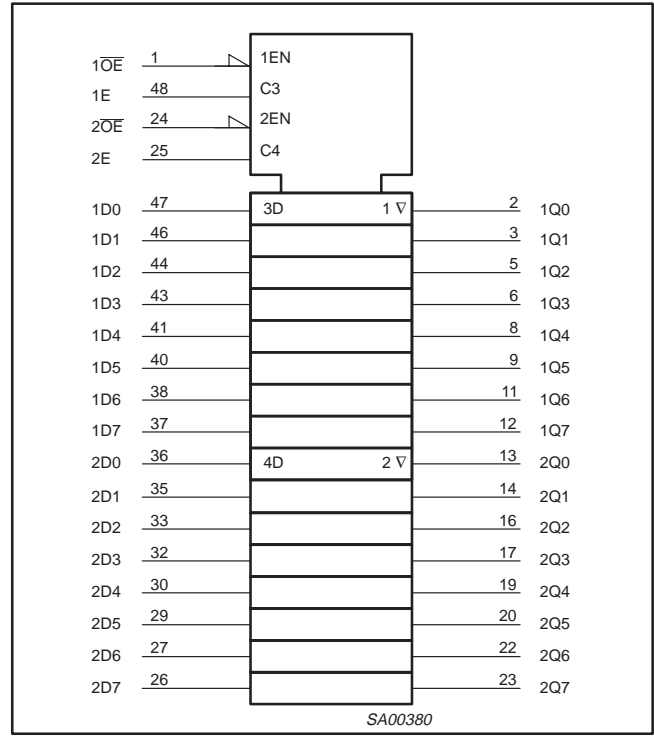

LOGIC SYMBOL

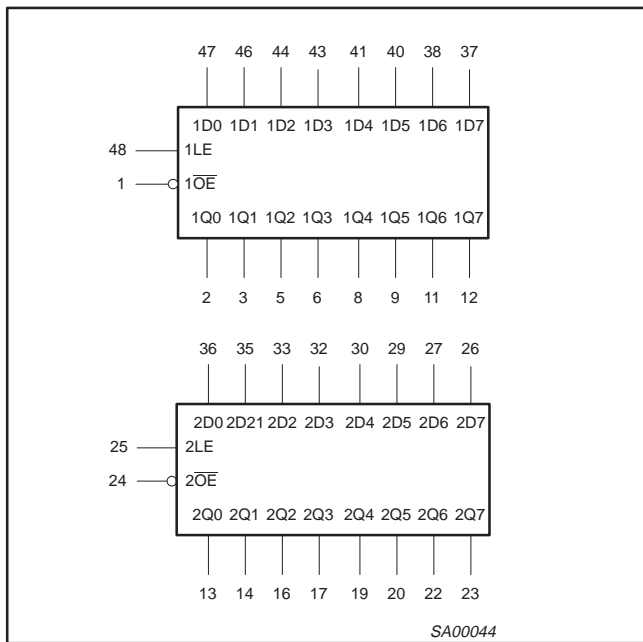

LOGIC DIAGRAM

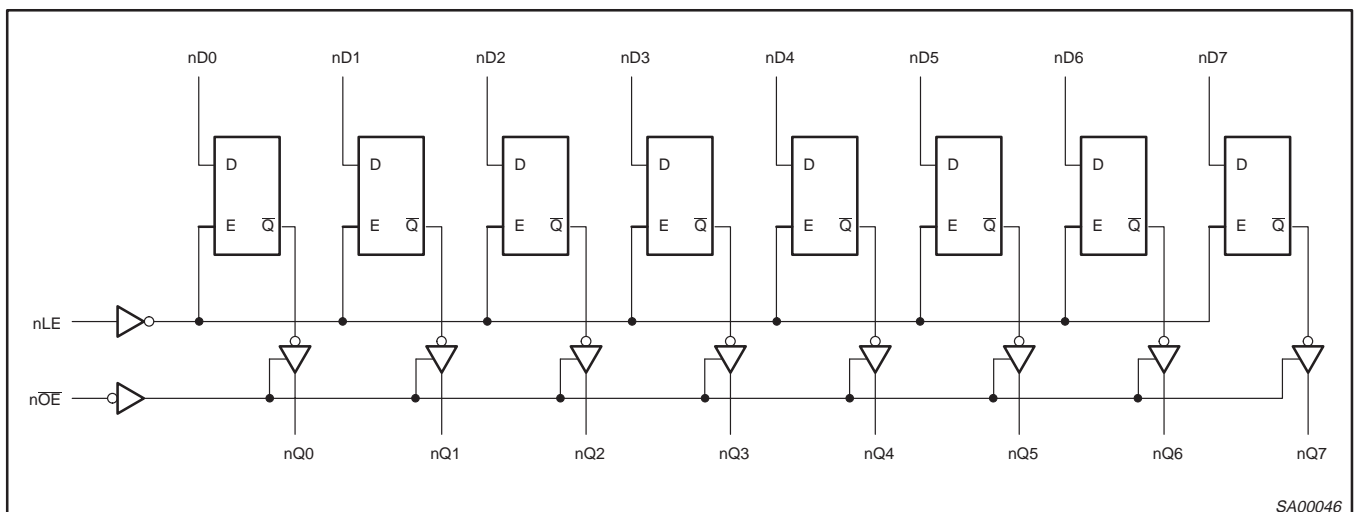

16-bit transparent latch (3-State)

74ABT16373B
74ABTH16373B

FUNCTION TABLE

INPUTS			INTERNAL REGISTER	OUTPUTS	OPERATING MODE
nOE	nE	nDx		nQ0 – nQ7	
L L	H H	L H	L H	L H	Enable and read register
L L	↓ ↓	i h	L H	L H	Latch and read register
L	L	X	NC	NC	Hold
H H	L H	X Dn	NC Dn	Z Z	Disable outputs

H = High voltage level

h = High voltage level one set-up time prior to the High-to-Low E transition

L = Low voltage level

l = Low voltage level one set-up time prior to the High-to-Low E transition

NC= No change

X = Don't care

Z = High impedance "off" state

↓ = High-to-Low E transition

ABSOLUTE MAXIMUM RATINGS^{1, 2}

SYMBOL	PARAMETER	CONDITIONS	RATING	UNIT
V _{CC}	DC supply voltage		-0.5 to +7.0	V
I _{IK}	DC input diode current	V _I < 0	-18	mA
V _I	DC input voltage ³		-1.2 to +7.0	V
I _{OK}	DC output diode current	V _O < 0	-50	mA
V _{OUT}	DC output voltage ³	output in Off or High state	-0.5 to +5.5	V
I _{OUT}	DC output current	output in Low state	128	mA
		output in High state	-64	
T _{stg}	Storage temperature range		-65 to 150	°C

NOTES:

- Stresses beyond those listed may cause permanent damage to the device. These are stress ratings only and functional operation of the device at these or any other conditions beyond those indicated under "recommended operating conditions" is not implied. Exposure to absolute-maximum-rated conditions for extended periods may affect device reliability.
- The performance capability of a high-performance integrated circuit in conjunction with its thermal environment can create junction temperatures which are detrimental to reliability. The maximum junction temperature of this integrated circuit should not exceed 150°C.
- The input and output voltage ratings may be exceeded if the input and output current ratings are observed.

RECOMMENDED OPERATING CONDITIONS

SYMBOL	PARAMETER	LIMITS		UNIT
		MIN	MAX	
V _{CC}	DC supply voltage	4.5	5.5	V
V _I	Input voltage	0	V _{CC}	V
V _{IH}	High-level input voltage	2.0		V
V _{IL}	Low-level Input voltage		0.8	V
I _{OH}	High-level output current		-32	mA
I _{OL}	Low-level output current		64	mA
Δt/Δv	Input transition rise or fall rate	0	10	ns/V
T _{amb}	Operating free-air temperature range	-40	+85	°C

16-bit transparent latch (3-State)

74ABT16373B
74ABTH16373B

DC ELECTRICAL CHARACTERISTICS

SYMBOL	PARAMETER	TEST CONDITIONS	LIMITS					UNIT	
			T _{amb} = +25°C			T _{amb} = -40°C to +85°C			
			MIN	TYP	MAX	MIN	MAX		
V _{IK}	Input clamp voltage	V _{CC} = 4.5V; I _{IK} = -18mA		-0.9	-1.2		-1.2	V	
V _{OH}	High-level output voltage	V _{CC} = 4.5V; I _{OH} = -3mA; V _I = V _{IL} or V _{IH}	2.5	2.9		2.5		V	
		V _{CC} = 5.0V; I _{OH} = -3mA; V _I = V _{IL} or V _{IH}	3.0	3.4		3.0		V	
		V _{CC} = 4.5V; I _{OH} = -32mA; V _I = V _{IL} or V _{IH}	2.0	2.4		2.0		V	
V _{OL}	Low-level output voltage	V _{CC} = 4.5V; I _{OL} = 64mA; V _I = V _{IL} or V _{IH}		0.42	0.55		0.55	V	
V _{RST}	Power-up output voltage ³	V _{CC} = 5.5V; I _O = 1mA; V _I = GND or V _{CC}		0.13	0.55		0.55	V	
I _I	Input leakage current 74ABT16373B	V _{CC} = 5.5V; V _I = V _{CC} or GND		±0.01	±1		±1	µA	
I _I	Input leakage current 74ABTH16373B	V _{CC} = 5.5V; V _I = V _{CC} or GND	Control pins	±0.01	±1		±1	µA	
		V _{CC} = 5.5V; V _I = V _{CC}	Data pins ⁵	0.01	1		1	µA	
		V _{CC} = 5.5V; V _I = 0		-1	-3		-5	µA	
I _{HOLD}	Bus Hold current A inputs ⁶ 74ABTH16373B	V _{CC} = 4.5V; V _I = 0.8V		50		50		µA	
		V _{CC} = 4.5V; V _I = 2.0V		-75		-75			
		V _{CC} = 5.5V; V _I = 0 to 5.5V		±800					
I _{OFF}	Power-off leakage current	V _{CC} = 0.0V; V _O or V _I ≤ 4.5V		±5.0	±100		±100	µA	
I _{PU} /I _{PD}	Power-up/down 3-State output current ⁴	V _{CC} = 2.1V; V _O = 0.5V; V _I = GND or V _{CC} ; V _{OE} = GND		±5.0	±50		±50	µA	
I _{OZH}	3-State output High current	V _{CC} = 5.5V; V _O = 5.5V; V _I = V _{IL} or V _{IH}		0.5	10		10	µA	
I _{OZL}	3-State output Low current	V _{CC} = 5.5V; V _O = 0.0V; V _I = V _{IL} or V _{IH}		-0.5	-10		-10	µA	
I _O	Output current ¹	V _{CC} = 5.5V; V _O = 2.5V		-50	-70	-180	-50	-180	mA
I _{CEX}	Output High leakage current	V _{CC} = 5.5V; V _O = 5.5V; V _I = GND or V _{CC}		0.1	50		50	µA	
I _{CCH}	Quiescent supply current	V _{CC} = 5.5V; Outputs High, V _I = GND or V _{CC}		0.5	2		2	mA	
I _{CCL}		V _{CC} = 5.5V; Outputs Low, V _I = GND or V _{CC}		8	19		19	mA	
I _{CCZ}		V _{CC} = 5.5V; Outputs 3-State; V _I = GND or V _{CC}		0.5	2		2	mA	
ΔI _{CC}	Additional supply current per input pin ² 74ABT16373B	V _{CC} = 5.5V; one input at 3.4V, other inputs at V _{CC} or GND		5	100		100	µA	
ΔI _{CC}	Additional supply current per input pin ² 74ABTH16373B	V _{CC} = 5.5V; one input at 3.4V, other inputs at V _{CC} or GND		0.5	1.5		1.5	mA	

NOTES:

- Not more than one output should be tested at a time, and the duration of the test should not exceed one second.
- This is the increase in supply current for each input at 3.4V.
- For valid test results, data must not be loaded into the flip-flops (or latches) after applying the power.
- This parameter is valid for any V_{CC} between 0V and 2.1V, with a transition time of up to 10msec. From V_{CC} = 2.1 to V_{CC} = 5V ± 10% a transition time of up to 100µsec is permitted.
- Unused pins at V_{CC} or GND.
- This is the bus hold overdrive current required to force the input to the opposite logic state.

16-bit transparent latch (3-State)

74ABT16373B
74ABTH16373B

AC CHARACTERISTICS

GND = 0V, $t_R = t_F = 2.5\text{ns}$, $C_L = 50\text{pF}$, $R_L = 500\Omega$

SYMBOL	PARAMETER	WAVEFORM	LIMITS					UNIT
			$T_{\text{amb}} = +25^\circ\text{C}$ $V_{\text{CC}} = +5.0\text{V}$			$T_{\text{amb}} = -40 \text{ to } +85^\circ\text{C}$ $V_{\text{CC}} = +5.0\text{V} \pm 0.5\text{V}$		
			MIN	TYP	MAX	MIN	MAX	
t_{PLH} t_{PHL}	Propagation delay nDx to nQx	2	1.5 1.1	2.5 2.0	3.8 3.1	1.5 1.1	4.4 3.8	ns
t_{PLH} t_{PHL}	Propagation delay nE to nQx	1	1.6 1.3	2.5 2.1	3.8 3.1	1.6 1.3	4.4 3.6	ns
t_{PZH} t_{PZL}	Output enable time to High and Low level	4 5	1.2 1.3	2.3 2.3	3.5 3.5	1.2 1.3	4.6 4.5	ns
t_{PHZ} t_{PLZ}	Output disable time from High and Low level	4 5	1.9 1.7	3.1 2.6	4.5 3.8	1.9 1.7	5.3 4.2	ns

AC SETUP REQUIREMENTS

GND = 0V, $t_R = t_F = 2.5\text{ns}$, $C_L = 50\text{pF}$, $R_L = 500\Omega$

SYMBOL	PARAMETER	WAVEFORM	LIMITS			UNIT
			$T_{\text{amb}} = +25^\circ\text{C}$ $V_{\text{CC}} = +5.0\text{V}$		$T_{\text{amb}} = -40 \text{ to } +85^\circ\text{C}$ $V_{\text{CC}} = +5.0\text{V} \pm 0.5\text{V}$	
			MIN	TYP	MIN	
$t_s(\text{H})$ $t_s(\text{L})$	Setup time, High or Low nDx to nE	3	1.0 1.0	0.0 0.3	1.0 1.0	ns
$t_h(\text{H})$ $t_h(\text{L})$	Hold time, High or Low nDx to nE	3	0.5 0.5	-0.2 0.0	0.5 0.5	ns
$t_w(\text{H})$	Enable pulse width High	1	2.5	1.0	2.5	ns

AC WAVEFORMS

For all waveforms, $V_M = 1.5\text{V}$.

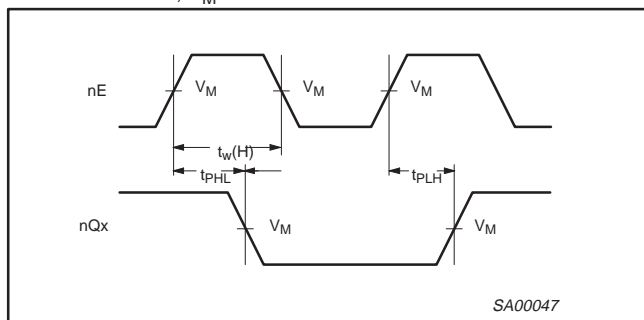

Waveform 1. Propagation Delay, Enable to Output, and Enable Pulse Width

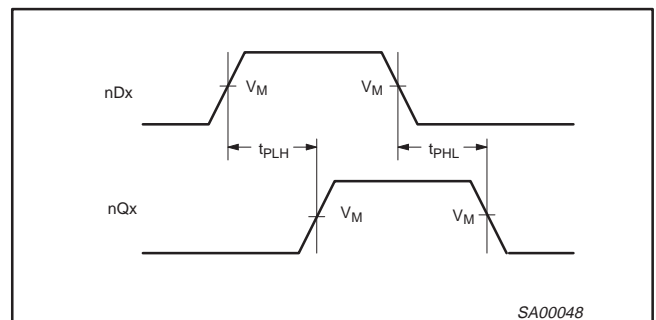

Waveform 2. Propagation Delay for Data to Outputs

16-bit transparent latch (3-State)

74ABT16373B
74ABTH16373B

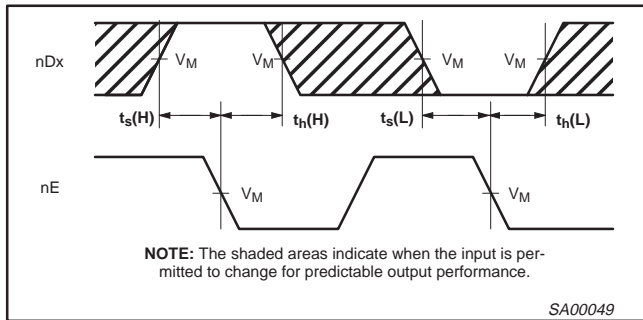

Waveform 3. Data Setup and Hold Times

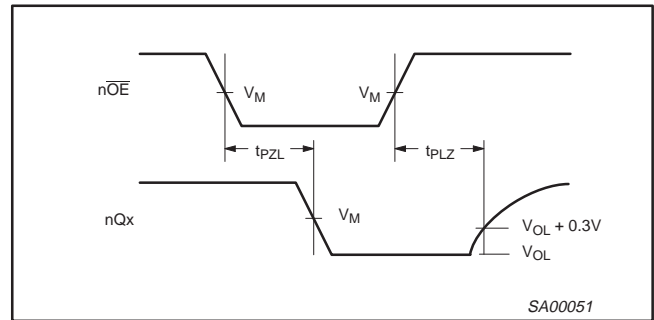

Waveform 5. 3-State Output Enable Time to Low Level and Output Disable Time from Low Level

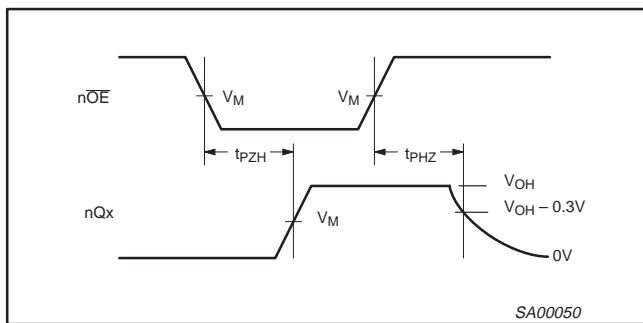

Waveform 4. 3-State Output Enable Time to High Level and Output Disable Time from High Level

TEST CIRCUIT AND WAVEFORM

Test Circuit for 3-State Outputs

Input Pulse Definition

$V_M = 1.5V$

SWITCH POSITION

TEST	SWITCH
t_{pLZ}	closed
t_{pZL}	closed
All other	open

DEFINITIONS

R_L = Load resistor; see AC CHARACTERISTICS for value.

C_L = Load capacitance includes jig and probe capacitance; see AC CHARACTERISTICS for value.

R_T = Termination resistance should be equal to Z_{OUT} of pulse generators.

SA00018

FAMILY	INPUT PULSE REQUIREMENTS				
	Amplitude	Rep. Rate	t_W	t_R	t_F
74ABT/H16	3.0V	1MHz	500ns	2.5ns	2.5ns

16-bit transparent latch (3-State)

74ABT16373B
74ABTH16373B

SSOP48: plastic shrink small outline package; 48 leads; body width 7.5 mm

SOT370-1

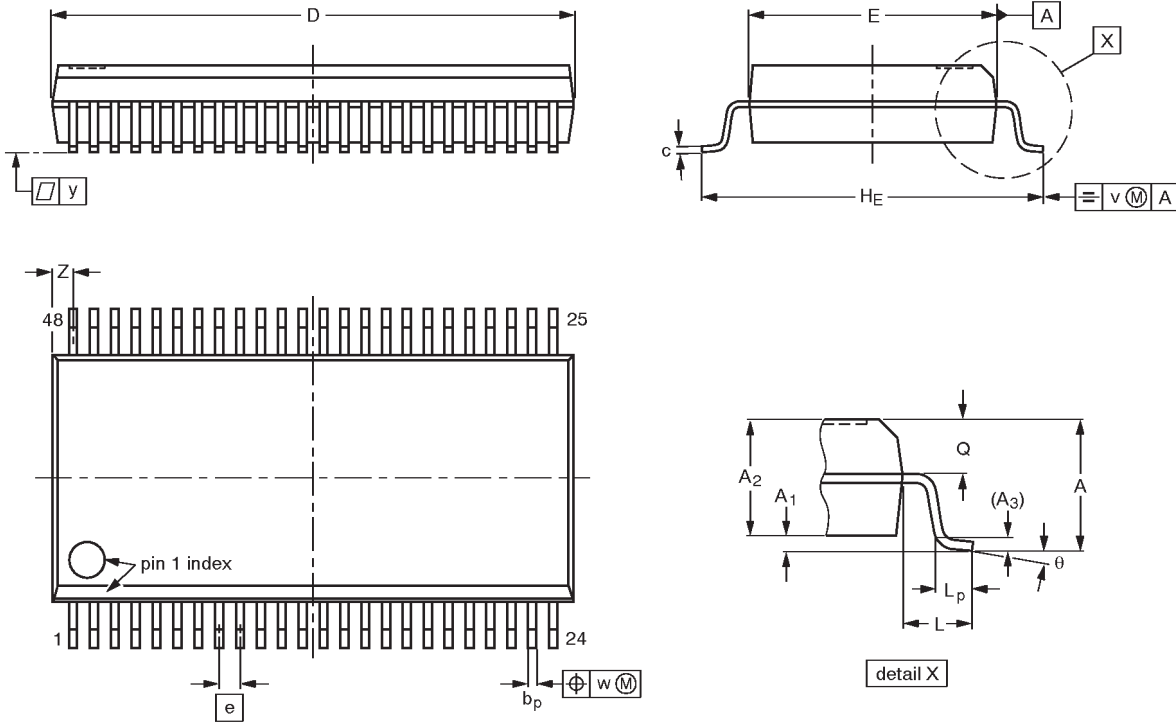

DIMENSIONS (mm are the original dimensions)

UNIT	A max.	A ₁	A ₂	A ₃	b _p	c	D ⁽¹⁾	E ⁽¹⁾	e	H _E	L	L _p	Q	v	w	y	Z ⁽¹⁾	θ
mm	2.8	0.4 0.2	2.35 2.20	0.25	0.3 0.2	0.22 0.13	16.00 15.75	7.6 7.4	0.635	10.4 10.1	1.4	1.0 0.6	1.2 1.0	0.25	0.18	0.1	0.85 0.40	8° 0°

Note

1. Plastic or metal protrusions of 0.25 mm maximum per side are not included.

OUTLINE VERSION	REFERENCES				EUROPEAN PROJECTION	ISSUE DATE
	IEC	JEDEC	EIAJ			
SOT370-1		MO-118AA				-93-11-02- 95-02-04

16-bit transparent latch (3-State)

74ABT16373B
74ABTH16373B

TSSOP48: plastic thin shrink small outline package; 48 leads; body width 6.1mm

SOT362-1

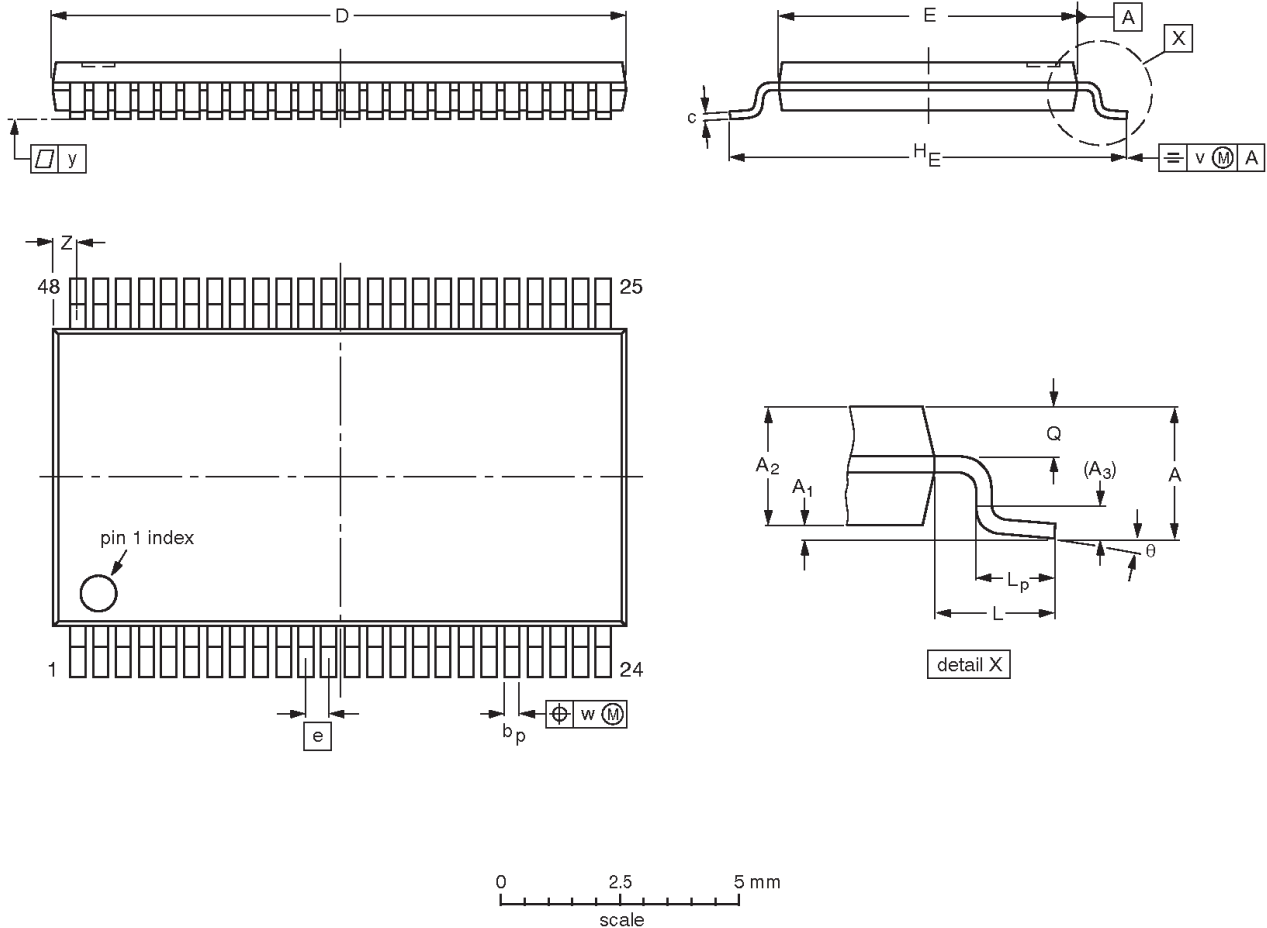

DIMENSIONS (mm are the original dimensions).

UNIT	A max.	A ₁	A ₂	A ₃	b _p	c	D ⁽¹⁾	E ⁽²⁾	e	H _E	L	L _p	Q	v	w	y	Z	θ
mm	1.2	0.15 0.05	1.05 0.85	0.25	0.28 0.17	0.2 0.1	12.6 12.4	6.2 6.0	0.5	8.3 7.9	1	0.8 0.4	0.50 0.35	0.25	0.08	0.1	0.8 0.4	8° 0°

Notes

1. Plastic or metal protrusions of 0.15 mm maximum per side are not included.
2. Plastic interlead protrusions of 0.25 mm maximum per side are not included.

OUTLINE VERSION	REFERENCES				EUROPEAN PROJECTION	ISSUE DATE
	IEC	JEDEC	EIAJ			
SOT362-1		MO-153ED				93-02-09 95-02-10

16-bit transparent latch (3-State)

74ABT16373B
74ABTH16373B

Data sheet status

Data sheet status	Product status	Definition [1]
Objective specification	Development	This data sheet contains the design target or goal specifications for product development. Specification may change in any manner without notice.
Preliminary specification	Qualification	This data sheet contains preliminary data, and supplementary data will be published at a later date. Philips Semiconductors reserves the right to make changes at any time without notice in order to improve design and supply the best possible product.
Product specification	Production	This data sheet contains final specifications. Philips Semiconductors reserves the right to make changes at any time without notice in order to improve design and supply the best possible product.

[1] Please consult the most recently issued datasheet before initiating or completing a design.

Definitions

Short-form specification — The data in a short-form specification is extracted from a full data sheet with the same type number and title. For detailed information see the relevant data sheet or data handbook.

Limiting values definition — Limiting values given are in accordance with the Absolute Maximum Rating System (IEC 134). Stress above one or more of the limiting values may cause permanent damage to the device. These are stress ratings only and operation of the device at these or at any other conditions above those given in the Characteristics sections of the specification is not implied. Exposure to limiting values for extended periods may affect device reliability.

Application information — Applications that are described herein for any of these products are for illustrative purposes only. Philips Semiconductors make no representation or warranty that such applications will be suitable for the specified use without further testing or modification.

Disclaimers

Life support — These products are not designed for use in life support appliances, devices or systems where malfunction of these products can reasonably be expected to result in personal injury. Philips Semiconductors customers using or selling these products for use in such applications do so at their own risk and agree to fully indemnify Philips Semiconductors for any damages resulting from such application.

Right to make changes — Philips Semiconductors reserves the right to make changes, without notice, in the products, including circuits, standard cells, and/or software, described or contained herein in order to improve design and/or performance. Philips Semiconductors assumes no responsibility or liability for the use of any of these products, conveys no license or title under any patent, copyright, or mask work right to these products, and makes no representations or warranties that these products are free from patent, copyright, or mask work right infringement, unless otherwise specified.

Philips Semiconductors
811 East Arques Avenue
P.O. Box 3409
Sunnyvale, California 94088-3409
Telephone 800-234-7381

© Copyright Philips Electronics North America Corporation 1998
All rights reserved. Printed in U.S.A.

print code

Date of release: 05-96

Document order number:

9397-750-03491

Let's make things better.



LittleDiode supplies new, hard to find or obsolete electronic components and semiconductors all over the world.

With over two million different components listed you are sure to find the part you need.

Feel free to visit us today at our online store:

LittleDiode.com

Looking forward to providing you with the best possible service.