

74ABT273 Octal D-Type Flip-Flop

General Description

The ABT273 has eight edge-triggered D-type flip-flops with individual D inputs and Q outputs. The common buffered Clock (CP) and Master Reset (\overline{MR}) inputs load and reset (clear) all flip-flops simultaneously.

The register is fully edge-triggered. The state of each D input, one setup time before the LOW-to-HIGH clock transition, is transferred to the corresponding flip-flop's Q output.

All outputs will be forced LOW independently of Clock or Data inputs by a LOW voltage level on the \overline{MR} input. The device is useful for applications where the true output only is required and the Clock and Master Reset are common to all storage elements.

Features

- Eight edge-triggered D-type flip-flops
- Buffered common clock
- Buffered, asynchronous Master Reset
- See ABT377 for clock enable version
- See ABT373 for transparent latch version
- See ABT374 for 3-STATE version
- Output sink capability of 64 mA, source capability of 32 mA
- Guaranteed latching protection
- High impedance glitch free bus loading during entire power up and power down cycle
- Non-destructive hot insertion capability
- Disable time less than enable time to avoid bus contention

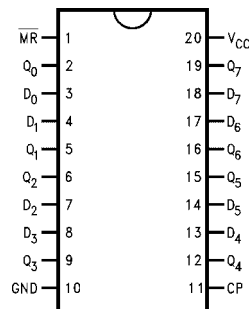
Ordering Code:

Order Number	Package Number	Package Description
74ABT273CSC	M20B	20-Lead Small Outline Integrated Circuit (SOIC), JEDEC MS-013, 0.300" Wide
74ABT273CSJ	M20D	Pb-Free 20-Lead Small Outline Package (SOP), EIAJ TYPE II, 5.3mm Wide
74ABT273CMSA	MSA20	20-Lead Shrink Small Outline Package (SSOP), JEDEC MO-150, 5.3mm Wide
74ABT273CMTC	MTC20	20-Lead Thin Shrink Small Outline Package (TSSOP), JEDEC MO-153, 4.4mm Wide
74ABT273CMTCX_NL (Note 1)	MTC20	Pb-Free 20-Lead Thin Shrink Small Outline Package (TSSOP), JEDEC MO-153, 4.4mm Wide

Device also available in Tape and Reel. Specify by appending suffix letter "X" to the ordering code.
Pb-Free package per JEDEC J-STD-020B.

Note 1: "_NL" indicates Pb-Free package (per JEDEC J-STD-020B). Device available in Tape and Reel only.

Connection Diagram



Pin Descriptions

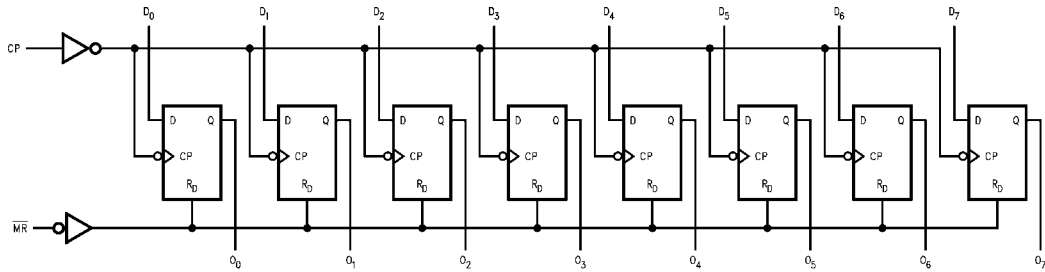
Pin Names	Description
D_0 - D_7	Data Inputs
\overline{MR}	Master Reset (Active LOW)
CP	Clock Pulse Input (Active Rising Edge)
Q_0 - Q_7	Data Outputs

Truth Table

Operating Mode	Inputs			Output
	\overline{MR}	CP	D_n	Q_n
Reset (Clear)	L	X	X	L
Load "1"	H	↗	h	H
Load "0"	H	↗	l	L

H = HIGH Voltage Level steady state
h = HIGH Voltage Level one setup time prior to the LOW-to-HIGH clock transition
L = LOW Voltage Level steady state
l = LOW Voltage Level one setup time prior to the LOW-to-HIGH clock transition
X = Immaterial
↗ = LOW-to-HIGH clock transition

Logic Diagram



Please note that this diagram is provided only for the understanding of logic operations and should not be used to estimate propagation delays.

Absolute Maximum Ratings (Note 2)

Storage Temperature	-65°C to +150°C
Ambient Temperature under Bias	-55°C to +125°C
Junction Temperature under Bias	-55°C to +150°C
V _{CC} Pin Potential to Ground Pin	-0.5V to +7.0V
Input Voltage (Note 3)	-0.5V to +7.0V
Input Current (Note 3)	-30 mA to +5.0 mA
Voltage Applied to Any Output in the Disabled or Power-Off State	-0.5V to +4.75V
in the HIGH State	-0.5V to V _{CC}
Current Applied to Output in LOW State (Max)	twice the rated I _{OL} (mA)
DC Latchup Source Current (Across Comm Operating Range)	-500 mA
Over Voltage Latchup	V _{CC} + 4.5V

Recommended Operating Conditions

Free Air Ambient Temperature	-40°C to +85°C
Supply Voltage	+4.5V to +5.5V
Minimum Input Edge Rate ($\Delta V/\Delta t$)	
Data Input	50 mV/ns
Enable Input	20 mV/ns

Note 2: Absolute maximum ratings are values beyond which the device may be damaged or have its useful life impaired. Functional operation under these conditions is not implied.

Note 3: Either voltage limit or current limit is sufficient to protect inputs.

DC Electrical Characteristics

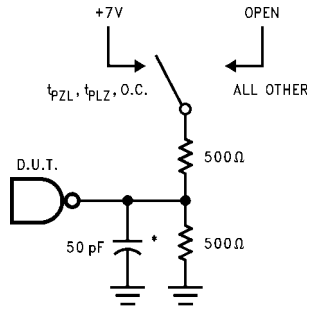
Symbol	Parameter	Min	Typ	Max	Units	V _{CC}	Conditions
V _{IH}	Input HIGH Voltage	2.0			V		Recognized HIGH Signal
V _{IL}	Input LOW Voltage			0.8	V		Recognized LOW Signal
V _{CD}	Input Clamp Diode Voltage			-1.2	V	Min	I _{IN} = -18 mA
V _{OH}	Output HIGH Voltage	2.5			V	Min	I _{OH} = -3 mA I _{OH} = -32 mA
V _{OL}	Output LOW Voltage			0.55	V	Min	I _{OL} = 64 mA
I _{IH}	Input HIGH Current			1	μA	Max	V _{IN} = 2.7V (Note 4) V _{IN} = V _{CC}
I _{BVI}	Input HIGH Current Breakdown Test			7	μA	Max	V _{IN} = 7.0V
I _{IL}	Input LOW Current			-1	μA	Max	V _{IN} = 0.5V (Note 4) V _{IN} = 0.0V
V _{ID}	Input Leakage Test	4.75			V	0.0	I _{ID} = 1.9 μA All Other Pins Grounded
I _{OS}	Output Short-Circuit Current	-100		-275	mA	Max	V _{OUT} = 0.0V
I _{CEX}	Output HIGH Leakage Current			50	μA	Max	V _{OUT} = V _{CC}
I _{CCH}	Power Supply Current			50	μA	Max	All Outputs HIGH
I _{CCL}	Power Supply Current			30	mA	Max	All Outputs LOW
I _{CCT}	Maximum I _{CC} /Input Outputs Enabled			1.5	mA	Max	V _I = V _{CC} - 2.1V Data Input V _I = V _{CC} - 2.1V All Others at V _{CC} or GND
I _{CCD}	Dynamic I _{CC} No Load			0.3	mA/ MHz	Max	Outputs Open (Note 5) One Bit Toggling, 50% Duty Cycle

Note 4: Guaranteed but not tested.

Note 5: For 8 bits toggling, I_{CCD} < 0.5 mA/MHz.

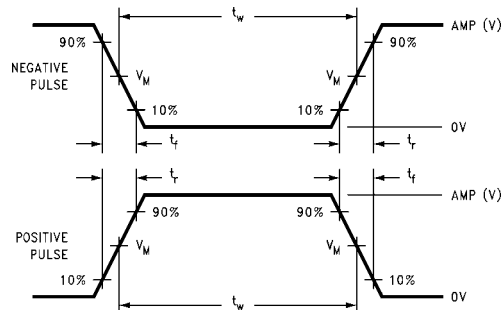
AC Electrical Characteristics									
(SSOIC package)									
Symbol	Parameter	T _A = +25°C V _{CC} = +5.0V C _L = 50 pF			T _A = -55°C to +125°C V _{CC} = 4.5V to 5.5V C _L = 50 pF		T _A = -40°C to +85°C V _{CC} = 4.5V to 5.5V C _L = 50 pF		Units
		Min	Typ	Max	Min	Max	Min	Max	
f _{MAX}	Maximum Clock Frequency	150	200		150		150		MHz
t _{PLH}	Propagation Delay	2.0		6.0	1.0	7.0	2.0	6.0	ns
t _{PHL}	CP to O _n	2.8		6.8	1.0	7.5	2.8	6.8	
t _{PHL}	Propagation Delay MR to O _n	2.5		7.4	1.0	8.2	2.5	7.4	ns
AC Operating Requirements									
Symbol	Parameter	T _A = +25°C V _{CC} = +5.0V C _L = 50 pF		T _A = -55°C to +125°C V _{CC} = 4.5V to 5.5V C _L = 50 pF		T _A = -40°C to +85°C V _{CC} = 4.5V to 5.5V C _L = 50 pF		Units	
		Min	Max	Min	Max	Min	Max		
t _S (H)	Setup Time, HIGH	2.0		2.0		2.0		ns	
t _S (L)	or LOW D _n to CP	2.5		2.5		2.5			
t _H (H)	Hold Time, HIGH	1.2		1.4		1.2		ns	
t _H (L)	or LOW D _n to CP	1.2		1.4		1.2			
t _W (H)	Pulse Width, CP,	3.3		3.3		3.3		ns	
t _W (L)	HIGH or LOW	3.3		3.3		3.3			
t _W (L)	Master Reset Pulse Width, LOW	3.3		3.3		3.3		ns	
t _{REC}	Recovery Time MR to CP	2.0		2.0		2.0		ns	
Capacitance									
(SOIC package)									
Symbol	Parameter	Typ	Units	Conditions T _A = 25°C					
C _{IN}	Input Capacitance	5	pF	V _{CC} = 0V					
C _{OUT} (Note 6)	Output Capacitance	9	pF	V _{CC} = 5.0V					
Note 6: C _{OUT} is measured at frequency f = 1 MHz, per MIL-STD-833, Method 3012.									

AC Loading



*Includes jig and probe capacitance

FIGURE 1. Standard AC Test Load

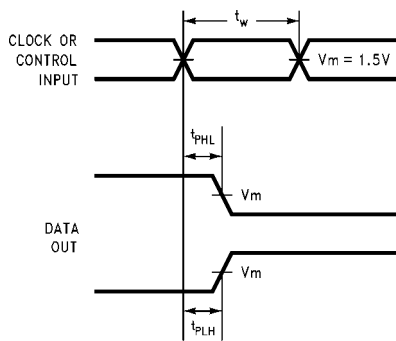


**FIGURE 2. $V_M = 1.5V$
Input Pulse Requirements**

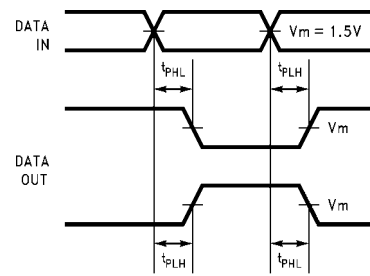
Amplitude	Rep. Rate	t_w	t_r	t_f
3.0V	1 MHz	500 ns	2.5 ns	2.5 ns

FIGURE 3. Test Input Signal Requirements

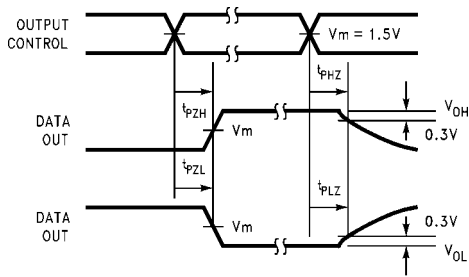
AC Waveforms



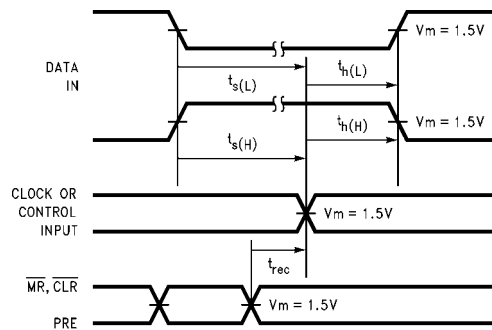
**FIGURE 4. Propagation Delay,
Pulse Width Waveforms**



**FIGURE 6. Propagation Delay Waveforms for
Inverting and Non-Inverting Functions**

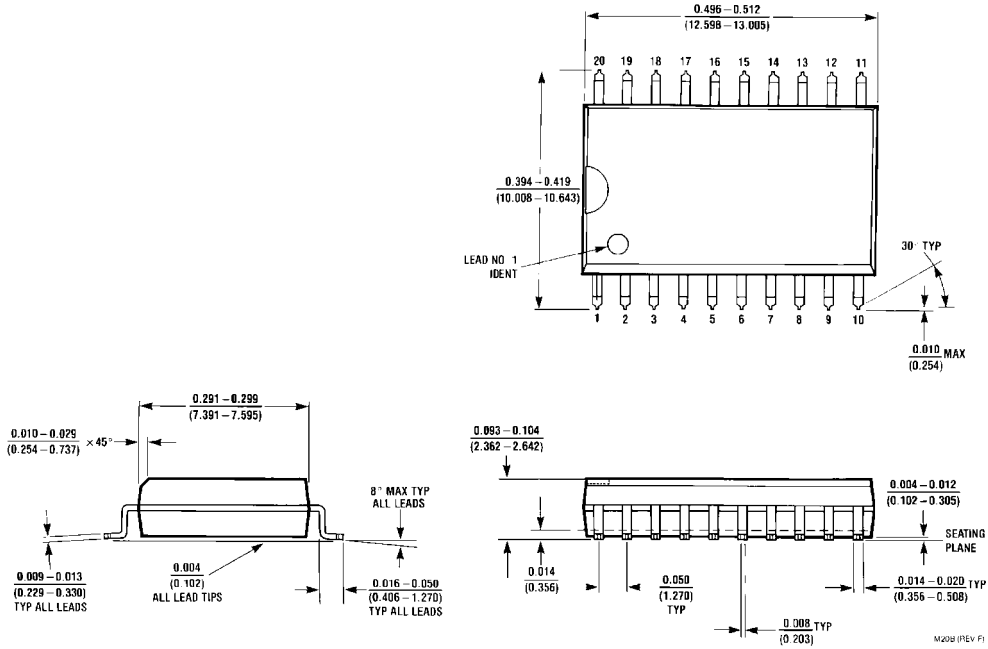


**FIGURE 5. 3-STATE Output HIGH
and LOW Enable and Disable Times**



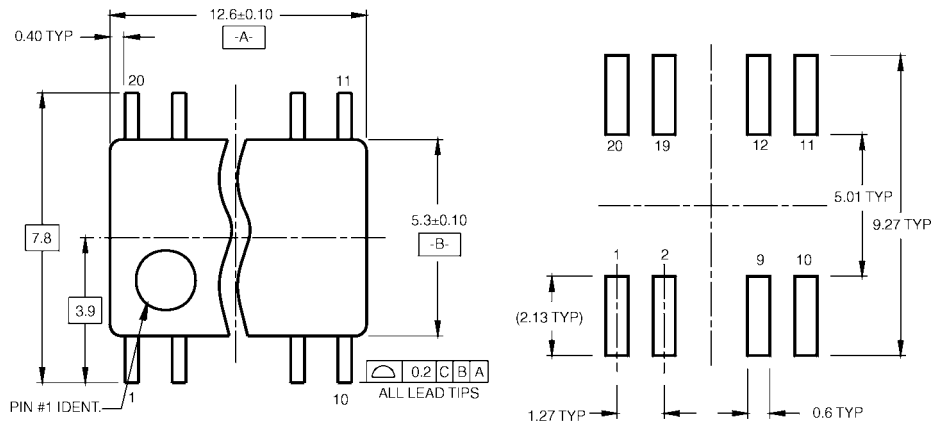
**FIGURE 7. Setup Time, Hold Time
and Recovery Time Waveforms**

Physical Dimensions inches (millimeters) unless otherwise noted

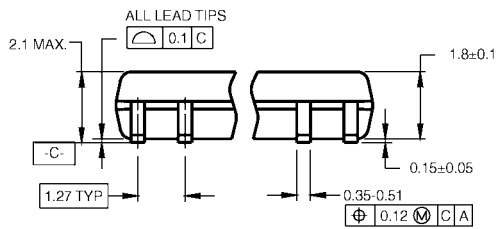


**20-Lead Small Outline Integrated Circuit (SOIC), JEDEC MS-013, 0.300" Wide
Package Number M20B**

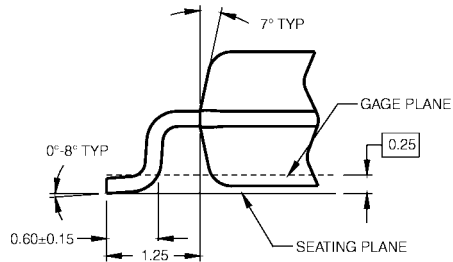
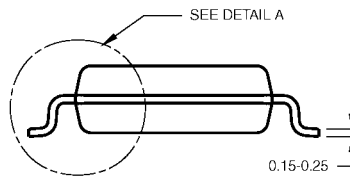
Physical Dimensions inches (millimeters) unless otherwise noted (Continued)



LAND PATTERN RECOMMENDATION



DIMENSIONS ARE IN MILLIMETERS



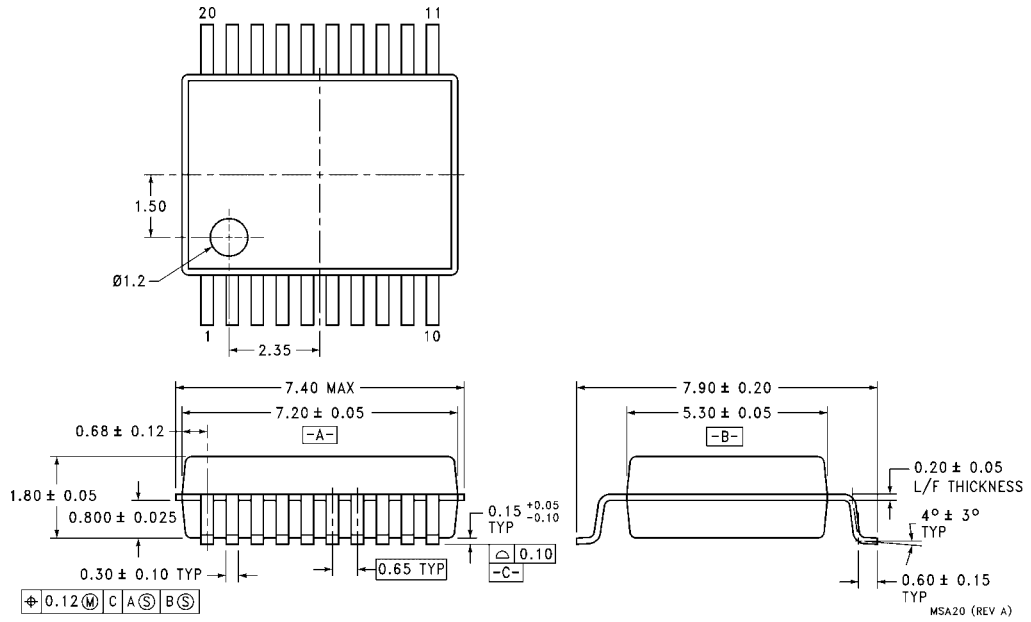
DETAIL A

- NOTES:
- A. CONFORMS TO EIAJ EDR-7320 REGISTRATION, ESTABLISHED IN DECEMBER, 1998.
 - B. DIMENSIONS ARE IN MILLIMETERS.
 - C. DIMENSIONS ARE EXCLUSIVE OF BURRS, MOLD FLASH, AND TIE BAR EXTRUSIONS.

M20DRevB1

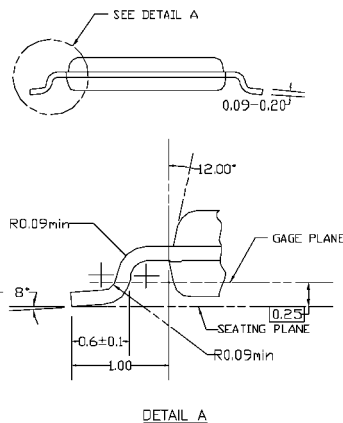
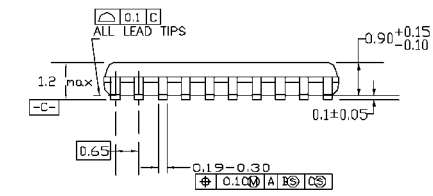
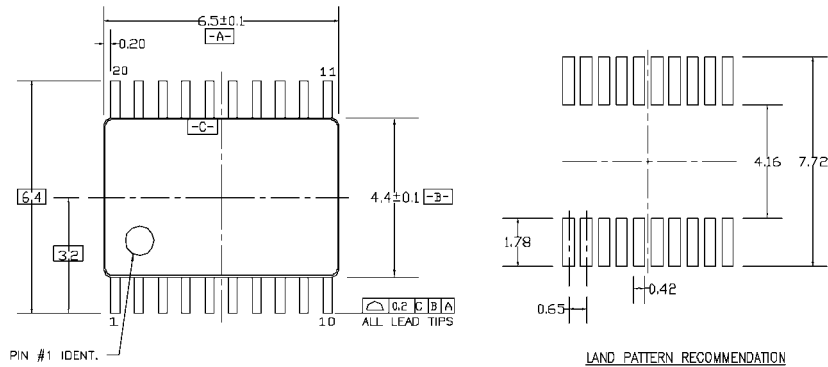
**Pb-Free 20-Lead Small Outline Package (SOP), EIAJ TYPE II, 5.3mm Wide
Package Number M20D**

Physical Dimensions inches (millimeters) unless otherwise noted (Continued)



**20-Lead Shrink Small Outline Package (SSOP), JEDEC MO-150, 5.3mm Wide
Package Number MSA20**

Physical Dimensions inches (millimeters) unless otherwise noted (Continued)



DIMENSIONS ARE IN MILLIMETERS

NOTES:

- A. CONFORMS TO JEDEC REGISTRATION MO-153, VARIATION AC, REF NOTE 6, DATE 7/93.
- B. DIMENSIONS ARE IN MILLIMETERS.
- C. DIMENSIONS ARE EXCLUSIVE OF BURRS, MOLDS FLASH, AND TIE BAR EXTRUSIONS.
- D. DIMENSIONS AND TOLERANCES PER ANSI Y14.5M, 1982.

MTC20REVD1

20-Lead Thin Shrink Small Outline Package (TSSOP), JEDEC MO-153, 4.4mm Wide Package Number MTC20

Fairchild does not assume any responsibility for use of any circuitry described, no circuit patent licenses are implied and Fairchild reserves the right at any time without notice to change said circuitry and specifications.

LIFE SUPPORT POLICY

FAIRCHILD'S PRODUCTS ARE NOT AUTHORIZED FOR USE AS CRITICAL COMPONENTS IN LIFE SUPPORT DEVICES OR SYSTEMS WITHOUT THE EXPRESS WRITTEN APPROVAL OF THE PRESIDENT OF FAIRCHILD SEMICONDUCTOR CORPORATION. As used herein:

1. Life support devices or systems are devices or systems which, (a) are intended for surgical implant into the body, or (b) support or sustain life, and (c) whose failure to perform when properly used in accordance with instructions for use provided in the labeling, can be reasonably expected to result in a significant injury to the user.
2. A critical component in any component of a life support device or system whose failure to perform can be reasonably expected to cause the failure of the life support device or system, or to affect its safety or effectiveness.

www.fairchildsemi.com



LittleDiode supplies new, hard to find or obsolete electronic components and semiconductors all over the world.

With over two million different components listed you are sure to find the part you need.

Feel free to visit us today at our online store:

LittleDiode.com

Looking forward to providing you with the best possible service.