

DATA SHEET

74ALS109A

Dual J- \bar{K} positive edge-triggered flip-flop
with set and reset

Product specification

1991 Feb 08

IC05 Data Handbook

Dual J-K̄ positive edge triggered flip-flop with set and reset

74ALS109A

DESCRIPTION

The 74ALS109A is a dual positive edge-triggered JK-type flip-flop featuring individual J, K̄, clock, set, and reset inputs; also true and complementary outputs. Set (\overline{SD}) and reset (\overline{RD}) are asynchronous active-Low inputs and operate independently of the clock (CP) input. The J and K̄ are edge-triggered inputs which control the state changes of the flip-flops as described in the function table. Clock triggering occurs at a voltage level and is not directly related to the transition time of the positive-going pulse. The J and K̄ inputs must be stable just one setup time prior to the Low-to-High transition of the clock for predictable operation. The JK̄ design allows operation as a D flip-flop by tying J and K̄ inputs together. Although the clock input is level sensitive, the positive transition of the clock pulse between the 0.8V and 2.0V levels should be equal to or less than the clock to output delay time for reliable operation.

PIN CONFIGURATION

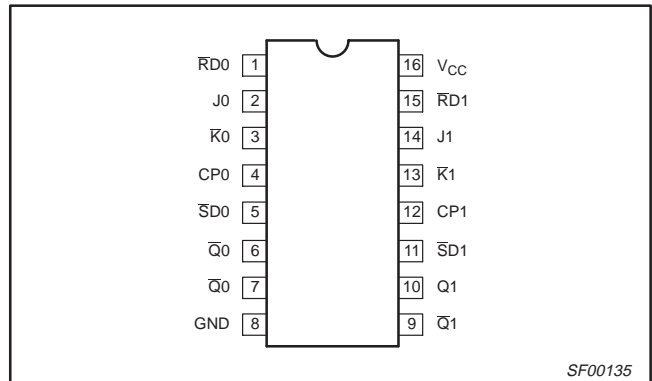

TYPE	TYPICAL f_{MAX}	TYPICAL SUPPLY CURRENT (TOTAL)
74ALS109A	150MHz	3.0mA

ORDERING INFORMATION

DESCRIPTION	ORDER CODE	DRAWING NUMBER
	COMMERCIAL RANGE $V_{CC} = 5V \pm 10\%$, $T_{amb} = 0^{\circ}C$ to $+70^{\circ}C$	
16-pin plastic DIP	74ALS109AN	SOT38-4
16-pin plastic SO	74ALS109AD	SOT109-1

INPUT AND OUTPUT LOADING AND FAN-OUT TABLE

PINS	DESCRIPTION	74ALS (U.L.) HIGH/LOW	LOAD VALUE HIGH/LOW
J0, J1	J inputs	1.0/2.0	20 μ A/0.2mA
K0, K1	K̄ inputs	1.0/2.0	20 μ A/0.2mA
CP0, CP1	Clock inputs (active rising edge)	1.0/2.0	20 μ A/0.2mA
SD0, SD1	Set inputs (active-Low)	1.0/4.0	20 μ A/0.4mA
RD0, RD1	Reset inputs (active-Low)	1.0/4.0	20 μ A/0.4mA
Q0, Q1, Q0, Q1	Data outputs	20/80	0.4mA/8mA

NOTE: One (1.0) ALS unit load is defined as: 20 μ A in the High state and 0.1mA in the Low state.

LOGIC SYMBOL

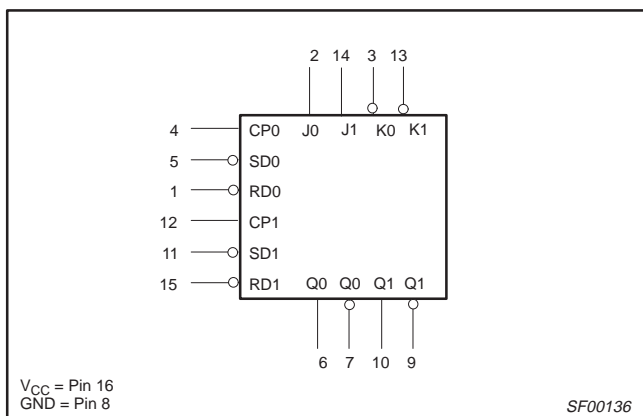

IEC/IEEE SYMBOL

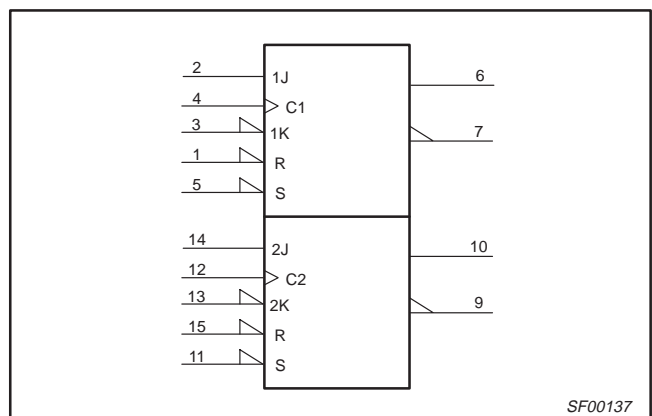

Dual J-K positive edge triggered flip-flop with set and reset

74ALS109A

LOGIC DIAGRAM

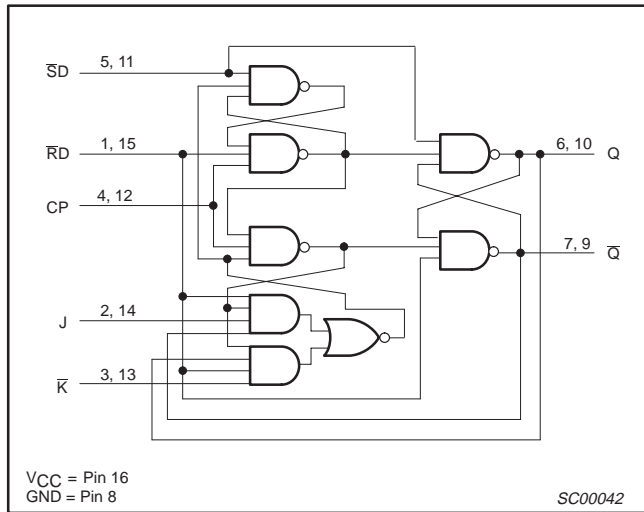

FUNCTION TABLE

INPUTS					OUTPUTS		OPERATING MODE
SD	RD	CP	J	K	Q	Q̄	
L	H	X	X	X	H	L	Asynchronous set
H	L	X	X	X	L	H	Asynchronous reset
L	L	X	X	X	H*	H*	Undetermined*
H	H	↑	h	l	q̄	q	Toggle
H	H	↑	l	l	L	H	Load "0"
H	H	↑	h	h	H	L	Load "1"
H	H	↑	l	h	q	q̄	Hold "no change"
H	H	L	l	h	q	q̄	Hold "no change"

- H = High voltage level
- h = High state must be present one setup time prior to Low-to-High clock transition
- L = Low voltage level
- l = Low state must be present one setup time prior to Low-to-High clock transition
- q = Lower case indicate the state of the referenced output prior to the Low-to-High clock transition
- X = Don't care
- ↑ = Low-to-High clock transition
- * = The output levels in this configuration are not guaranteed to meet the minimum levels for V_{OH} if the set and reset are near V_{IN} maximum. Furthermore, this configuration is nonstable; that is, it will not remain when either set or reset returns to its inactive (High) level.

ABSOLUTE MAXIMUM RATINGS

(Operation beyond the limit set forth in this table may impair the useful life of the device. Unless otherwise noted these limits are over the operating free-air temperature range.)

SYMBOL	PARAMETER	RATING	UNIT
V_{CC}	Supply voltage	-0.5 to +7.0	V
V_{IN}	Input voltage	-0.5 to +7.0	V
I_{IN}	Input current	-30 to +5	mA
V_{OUT}	Voltage applied to output in high output state	-0.5 to V_{CC}	V
I_{OUT}	Current applied to output in Low output state	16	mA
T_{amb}	Operating free-air temperature range	0 to +70	°C
T_{stg}	Storage temperature range	-65 to +150	°C

RECOMMENDED OPERATING CONDITIONS

SYMBOL	PARAMETER	LIMITS			UNIT
		MIN	NOM	MAX	
V_{CC}	Supply voltage	4.5	5.0	5.5	V
V_{IH}	High-level input voltage	2.0			V
V_{IL}	Low-level input voltage			0.8	V
I_{IK}	Input clamp current			-18	mA
I_{OH}	High-level output current			-0.4	mA
I_{OL}	Low-level output current			8	mA
T_{amb}	Operating free-air temperature range	0		+70	°C

Dual J- \bar{K} positive edge triggered flip-flop with set and reset

74ALS109A

DC ELECTRICAL CHARACTERISTICS

(Over recommended operating free-air temperature range unless otherwise noted.)

SYMBOL	PARAMETER	TEST CONDITIONS ¹	LIMITS			UNIT
			MIN	TYP ²	MAX	
V _{OH}	High-level output voltage	V _{CC} = ±10%, V _{IL} = MAX, V _{IH} = MIN I _{OH} = -0.4mA	V _{CC} - 2			V
V _{OL}	Low-level output voltage	V _{CC} = MIN, V _{IL} = MAX, V _{IH} = MIN	I _{OL} = 4mA	0.25	0.40	V
			I _{OL} = 8mA	0.35	0.50	V
V _{IK}	Input clamp voltage	V _{CC} = MIN, I _I = I _{IK}		-0.73	-1.5	V
I _I	Input current at maximum input voltage	Jn, \bar{K} n, CPn \bar{S} Dn, \bar{R} Dn	V _{CC} = MAX, V _I = 7.0V		0.1	mA
					0.2	mA
I _{IH}	High-level input current	Jn, \bar{K} n, CPn \bar{S} Dn, \bar{R} Dn	V _{CC} = MAX, V _I = 2.7V		20	μA
					40	μA
I _{IL}	Low-level input current	Jn, \bar{K} n, CPn \bar{S} Dn, \bar{R} Dn	V _{CC} = MAX, V _I = 0.4V		-0.2	mA
					-0.4	mA
I _O	Output current ³	V _{CC} = MAX, V _O = 2.25V	-30		-112	mA
I _{CC}	Supply current (total) ⁴	V _{CC} = MAX		3.0	4.0	mA

NOTES:

- For conditions shown as MIN or MAX, use the appropriate value specified under recommended operating conditions for the applicable type.
- All typical values are at V_{CC} = 5V, T_{amb} = 25°C.
- The output conditions have been chosen to produce a current that closely approximates one half of the true short-circuit output current, I_{OS}.
- Measure I_{CC} with the clock input grounded and all outputs open, then with Q and \bar{Q} outputs High in turn.

AC ELECTRICAL CHARACTERISTICS

SYMBOL	PARAMETER	TEST CONDITION	LIMITS		UNIT
			T _{amb} = 0°C to +70°C V _{CC} = +5.0V ± 10% C _L = 50pF, R _L = 500Ω		
			MIN	MAX	
f _{MAX}	Maximum clock frequency	Waveform 1	80		MHz
t _{PLH} t _{PHL}	Propagation delay CPn to Qn or \bar{Q} n	Waveform 1	3.0	14.0	ns
			3.0	14.0	
t _{PLH} t _{PHL}	Propagation delay \bar{S} Dn or \bar{R} Dn to Qn or \bar{Q} n	Waveform 2, 3	1.0	8.0	ns
			3.0	10.0	

AC SETUP REQUIREMENTS

SYMBOL	PARAMETER	TEST CONDITION	LIMITS		UNIT
			T _{amb} = 0°C to +70°C V _{CC} = +5.0V ± 10% C _L = 50pF, R _L = 500Ω		
			MIN	MAX	
t _{su} (H) t _{su} (L)	Setup time, High or Low Jn, \bar{K} n to CPn	Waveform 1	6.0		ns
			6.0		
t _h (H) t _h (L)	Hold time, High or Low Jn, \bar{K} n to CPn	Waveform 1	0.0		ns
			0.0		
t _w (H) t _w (L)	CPn Pulse width High or Low	Waveform 1	6.0		ns
			6.0		
t _w (L)	\bar{S} Dn or \bar{R} Dn Pulse width Low	Waveform 2, 3	6.0		ns
t _{rec}	Recovery time, \bar{S} Dn or \bar{R} Dn to CPn	Waveform 2, 3	6.0		ns

Dual J-K positive edge triggered flip-flop with set and reset

74ALS109A

AC WAVEFORMS

For all waveforms, $V_M = 1.3V$.

The shaded areas indicate when the input is permitted to change for predictable output performance.

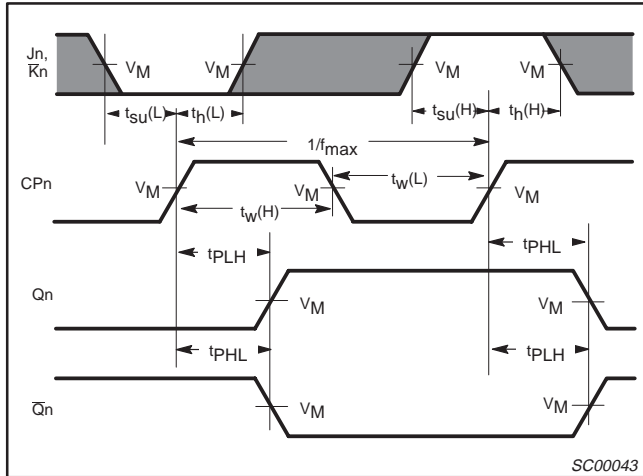

Waveform 1. Propagation Delay for Data to Output, Data Setup Time and Hold Times, Clock Width, and Maximum Clock Frequency

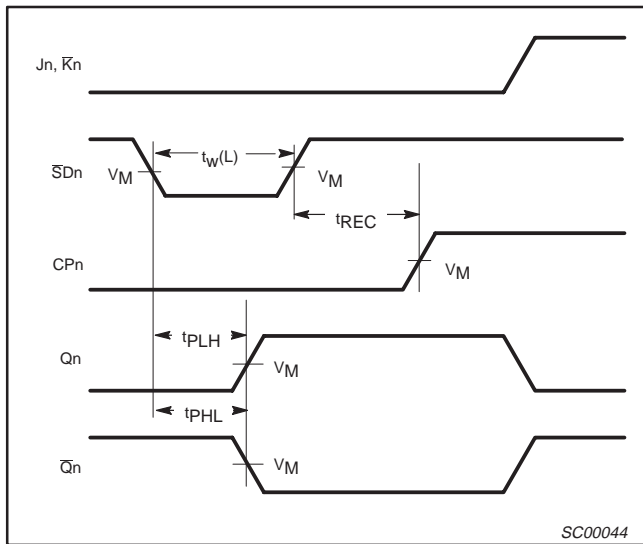

Waveform 2. Propagation Delay for Set to Output, Set Pulse Width and Recovery Time for Set to Clock

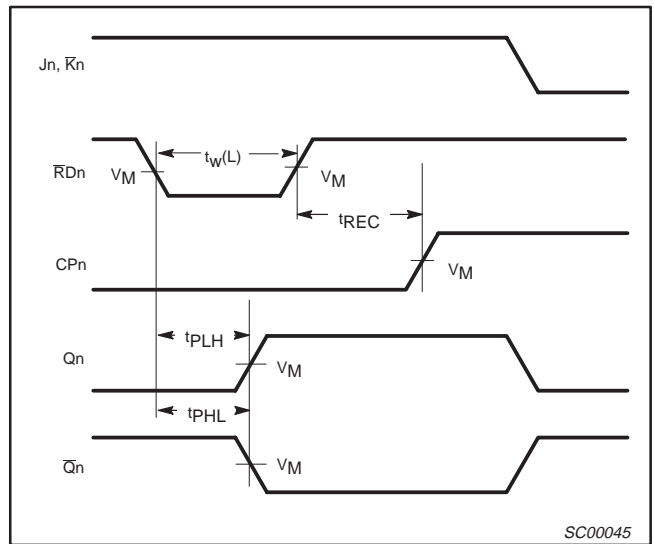

Waveform 3. Propagation Delay for Reset to Output, Reset Pulse Width and Recovery Time for Reset to Clock

Dual J-K positive edge triggered flip-flop with set and reset

74ALS109A

TEST CIRCUIT AND WAVEFORMS

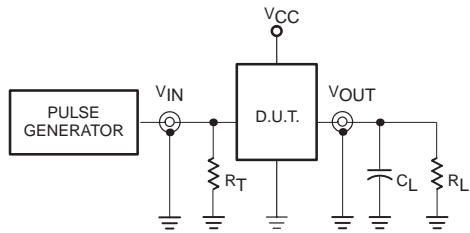

Test Circuit for Totem-pole Outputs

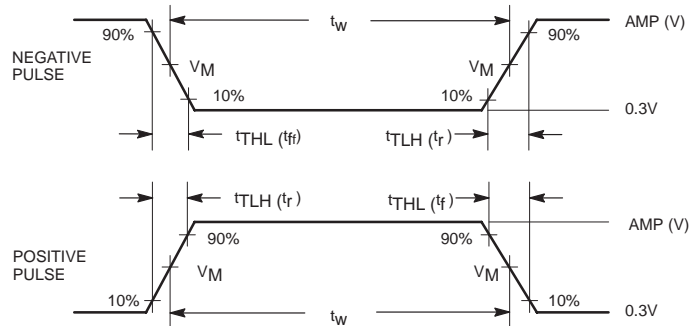

Input Pulse Definition

DEFINITIONS:

- R_L = Load resistor; see AC electrical characteristics for value.
- C_L = Load capacitance includes jig and probe capacitance; see AC electrical characteristics for value.
- R_T = Termination resistance should be equal to Z_{OUT} of pulse generators.

Family	INPUT PULSE REQUIREMENTS					
	Amplitude	V_M	Rep.Rate	t_w	t_{TLH}	t_{THL}
74ALS	3.5V	1.3V	1MHz	500ns	2.0ns	2.0ns

SC00005

Dual J-K positive edge-triggered flip-flop with set and reset

74ALS109A

DIP16: plastic dual in-line package; 16 leads (300 mil)

SOT38-4

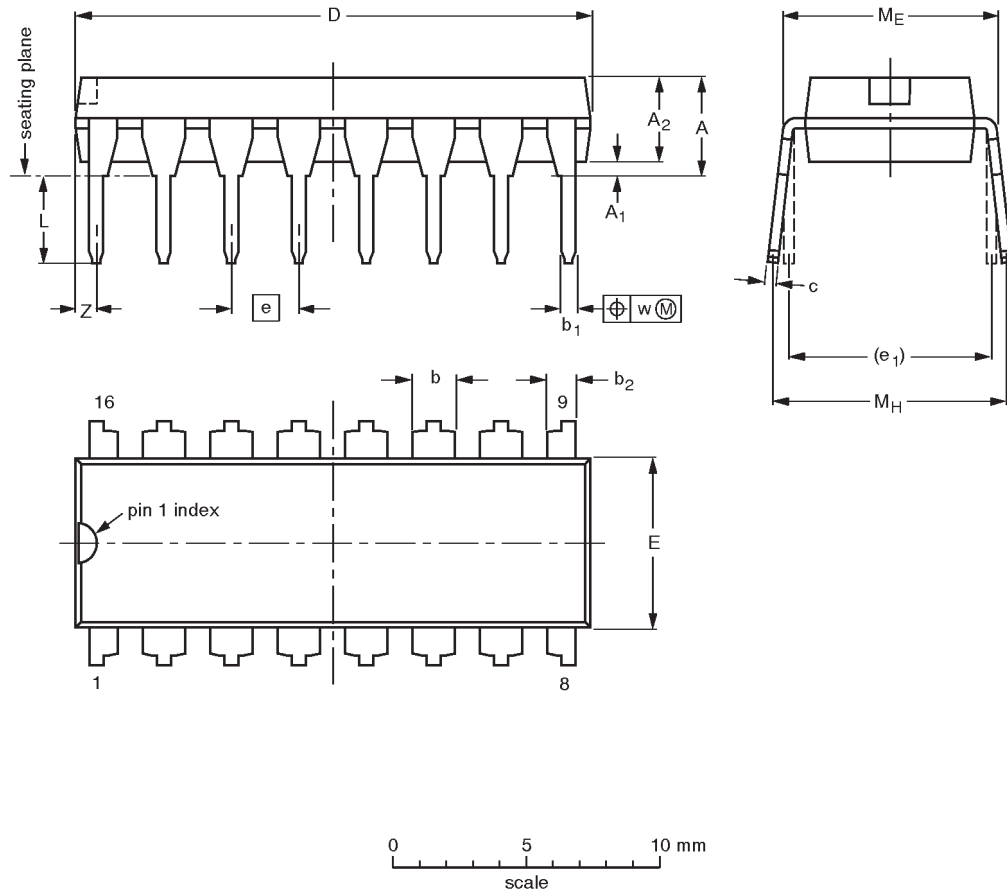

DIMENSIONS (inch dimensions are derived from the original mm dimensions)

UNIT	A max.	A ₁ min.	A ₂ max.	b	b ₁	b ₂	c	D ⁽¹⁾	E ⁽¹⁾	e	e ₁	L	M _E	M _H	w	Z ⁽¹⁾ max.
mm	4.2	0.51	3.2	1.73 1.30	0.53 0.38	1.25 0.85	0.36 0.23	19.50 18.55	6.48 6.20	2.54	7.62	3.60 3.05	8.25 7.80	10.0 8.3	0.254	0.76
inches	0.17	0.020	0.13	0.068 0.051	0.021 0.015	0.049 0.033	0.014 0.009	0.77 0.73	0.26 0.24	0.10	0.30	0.14 0.12	0.32 0.31	0.39 0.33	0.01	0.030

Note

1. Plastic or metal protrusions of 0.25 mm maximum per side are not included.

OUTLINE VERSION	REFERENCES				EUROPEAN PROJECTION	ISSUE DATE
	IEC	JEDEC	EIAJ			
SOT38-4						92-11-17 95-01-14

Dual J-K positive edge-triggered flip-flop with set and reset

74ALS109A

SO16: plastic small outline package; 16 leads; body width 3.9 mm

SOT109-1

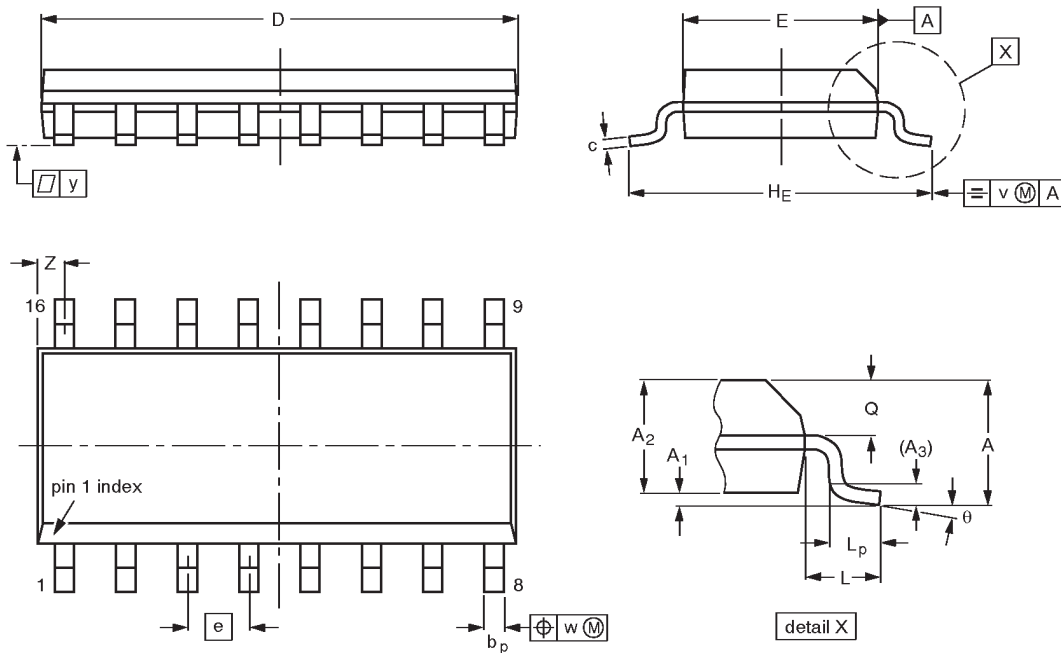

DIMENSIONS (inch dimensions are derived from the original mm dimensions)

UNIT	A max.	A ₁	A ₂	A ₃	b _p	c	D ⁽¹⁾	E ⁽¹⁾	e	H _E	L	L _p	Q	v	w	y	z ⁽¹⁾	θ
mm	1.75	0.25 0.10	1.45 1.25	0.25	0.49 0.36	0.25 0.19	10.0 9.8	4.0 3.8	1.27	6.2 5.8	1.05	1.0 0.4	0.7 0.6	0.25	0.25	0.1	0.7 0.3	8° 0°
inches	0.069	0.0098 0.0039	0.057 0.049	0.01	0.019 0.014	0.0098 0.0075	0.39 0.38	0.16 0.15	0.050	0.24 0.23	0.041	0.039 0.016	0.028 0.020	0.01	0.01	0.004	0.028 0.012	

Note

1. Plastic or metal protrusions of 0.15 mm maximum per side are not included.

OUTLINE VERSION	REFERENCES				EUROPEAN PROJECTION	ISSUE DATE
	IEC	JEDEC	EIAJ			
SOT109-1	076E07S	MS-012AC				91-08-13 95-01-23

Dual J-K positive edge-triggered flip-flop with set and reset

74ALS109A

DEFINITIONS

Data Sheet Identification	Product Status	Definition
<i>Objective Specification</i>	Formative or in Design	This data sheet contains the design target or goal specifications for product development. Specifications may change in any manner without notice.
<i>Preliminary Specification</i>	Preproduction Product	This data sheet contains preliminary data, and supplementary data will be published at a later date. Philips Semiconductors reserves the right to make changes at any time without notice in order to improve design and supply the best possible product.
<i>Product Specification</i>	Full Production	This data sheet contains Final Specifications. Philips Semiconductors reserves the right to make changes at any time without notice, in order to improve design and supply the best possible product.

Philips Semiconductors and Philips Electronics North America Corporation reserve the right to make changes, without notice, in the products, including circuits, standard cells, and/or software, described or contained herein in order to improve design and/or performance. Philips Semiconductors assumes no responsibility or liability for the use of any of these products, conveys no license or title under any patent, copyright, or mask work right to these products, and makes no representations or warranties that these products are free from patent, copyright, or mask work right infringement, unless otherwise specified. Applications that are described herein for any of these products are for illustrative purposes only. Philips Semiconductors makes no representation or warranty that such applications will be suitable for the specified use without further testing or modification.

LIFE SUPPORT APPLICATIONS

Philips Semiconductors and Philips Electronics North America Corporation Products are not designed for use in life support appliances, devices, or systems where malfunction of a Philips Semiconductors and Philips Electronics North America Corporation Product can reasonably be expected to result in a personal injury. Philips Semiconductors and Philips Electronics North America Corporation customers using or selling Philips Semiconductors and Philips Electronics North America Corporation Products for use in such applications do so at their own risk and agree to fully indemnify Philips Semiconductors and Philips Electronics North America Corporation for any damages resulting from such improper use or sale.

Philips Semiconductors
811 East Arques Avenue
P.O. Box 3409
Sunnyvale, California 94088-3409
Telephone 800-234-7381

© Copyright Philips Electronics North America Corporation 1997
All rights reserved. Printed in U.S.A.

Let's make things better.



LittleDiode supplies new, hard to find or obsolete electronic components and semiconductors all over the world.

With over two million different components listed you are sure to find the part you need.

Feel free to visit us today at our online store:

LittleDiode.com

Looking forward to providing you with the best possible service.