

DATA SHEET

74F1604

Latch

Product specification

1990 Oct 04

IC15 Data Handbook

Latch

74F1604

FEATURES

- High impedance NPN base inputs for reduced loading (20µA in high and low state)
- Stores 16-bit wide data inputs, multiplexed 8-bit outputs
- Propagation delay 7.0ns typical
- Power supply current 70mA typical

DESCRIPTION

The 74F1604 is a dual octal transparent latch. Organized as 8-bit A and B latches, the latch outputs are connected by pairs to eight 2-input multiplexers. A select (SELECT A/B) input determines whether the A or B latch contents are multiplexed to the eight outputs. Data from the B inputs are selected when SELECT A/B is low; data from the A inputs are selected when SELECT A/B is high. Data enters the latch on the falling edge of the latch enable (LE) input. The latch remains transparent to the data inputs while LE is low, and stores the data that is present one setup time before the low-to-high latch enable transition.

TYPE	TYPICAL PROPAGATION DELAY	TYPICAL SUPPLY CURRENT (TOTAL)
74F1604	7.0ns	70mA

ORDERING INFORMATION

DESCRIPTION	ORDER CODE	PKG DWG #
	COMMERCIAL RANGE	
	$V_{CC} = 5V \pm 10\%$, $T_{amb} = 0^{\circ}C \text{ to } +70^{\circ}C$	
28-pin plastic DIP	N74F1604N	SOT117-2
28-pin plastic SOL	N74F1604D	SOT136-1

INPUT AND OUTPUT LOADING AND FAN OUT TABLE

PINS	DESCRIPTION	74F (U.L.) HIGH/LOW	LOAD VALUE HIGH/LOW
A0 – A7	Data inputs	1.0/0.033	20µA/20µA
B0 – B7	Data inputs	1.0/0.033	20µA/20µA
SELECT A/B	Select input	1.0/0.033	20µA/20µA
LE	Latch enable input (active low)	1.0/0.033	20µA/20µA
Q0 – Q7	Data outputs	50/33	1.0mA/20mA

Note to input and output loading and fan out table
 One (1.0) FAST unit load is defined as: 20µA in the high state and 0.6mA in the low state.

PIN CONFIGURATION

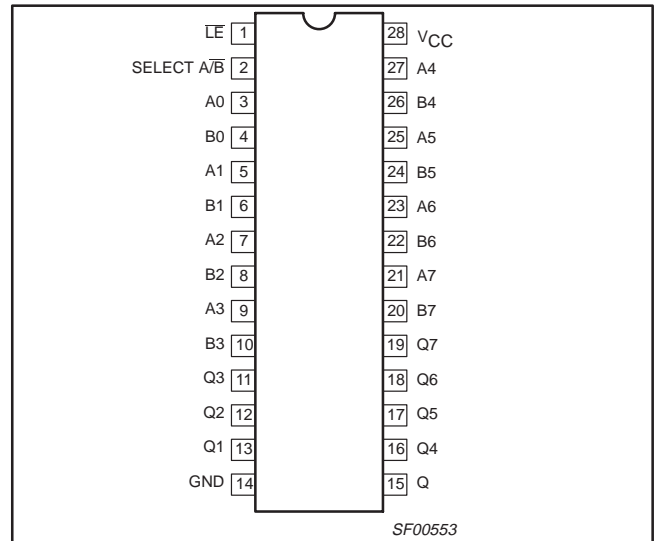

LOGIC SYMBOL

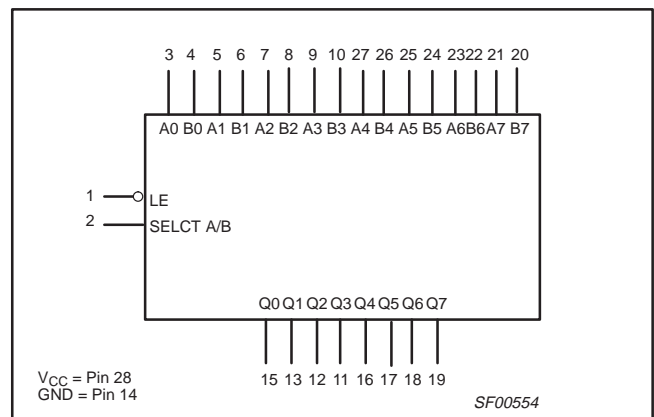

IEC/IEEE SYMBOL

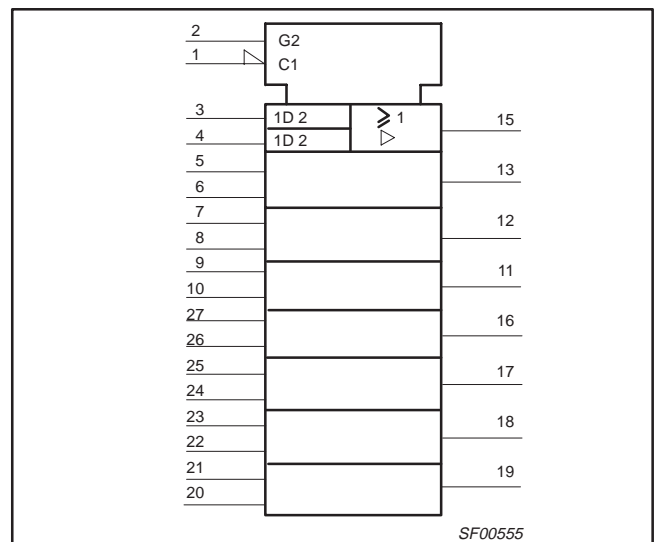

Latch

74F1604

LOGIC DIAGRAM

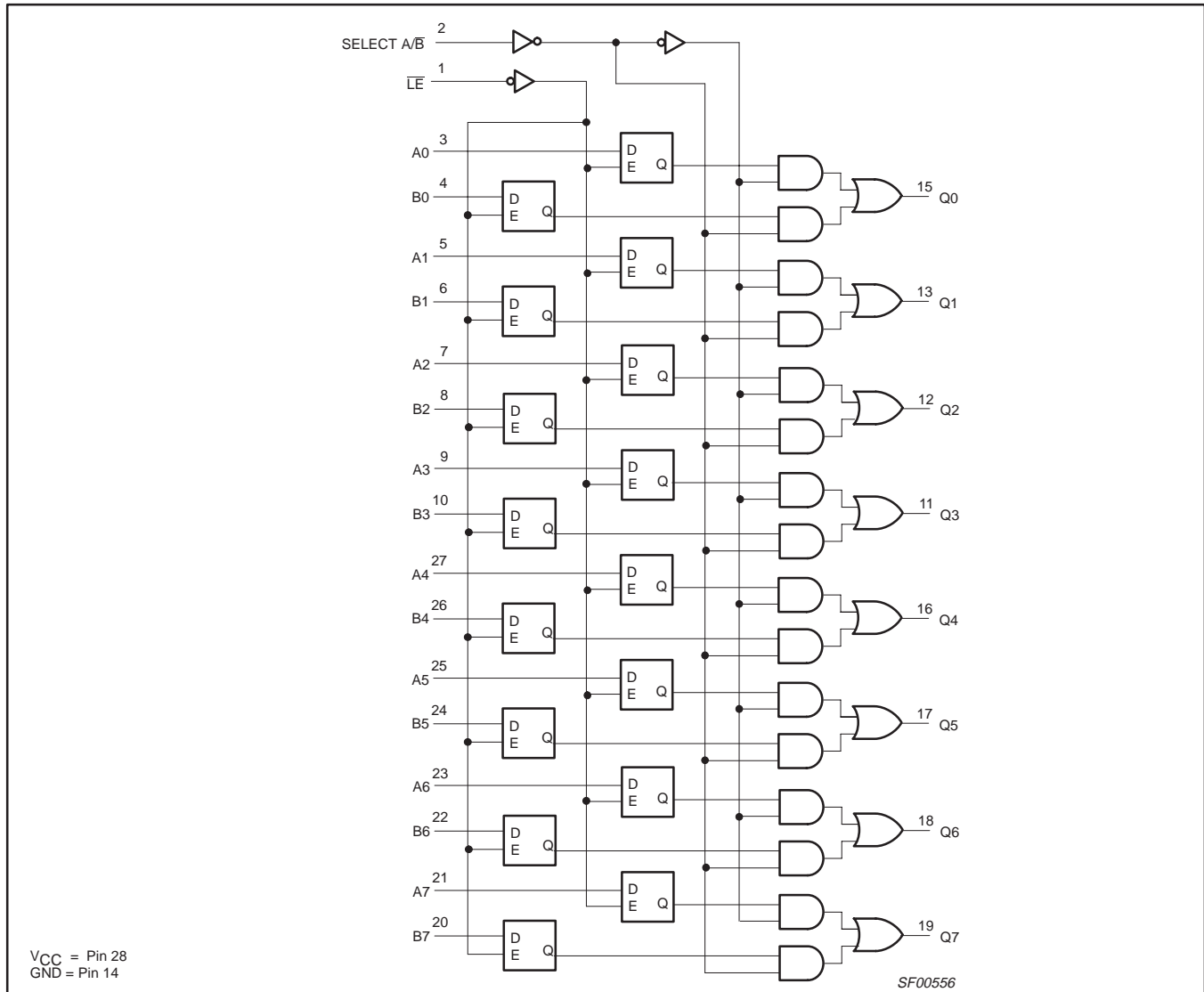

FUNCTION TABLE

INPUTS				OUTPUTS	OUTPUTS
OPERATING MODE	A0 – A7	B0 – B7	SELECT A/B	Q0 – Q7	
	A data	B data	L	B data	Enable and read register
	A data	B data	H	A data	
	X	X	X	NC	Hold
	A data	B data	l	B data	Latch and read register
	A data	B data	h	A data	

Notes to function table

- H = High-voltage level
- h = High-voltage level one setup time before the low-to-high latch enable transition
- L = Low-voltage level
- l = Low-voltage level one setup time before the low-to-high latch enable transition
- NC = No change (If SELECT A/B is toggled and the A latched data is different from B latched data then the output will change accordingly.)
- X = Don't care
- ↑ = Low-to-high latch enable transition

Latch

74F1604

ABSOLUTE MAXIMUM RATINGS

(Operation beyond the limit set forth in this table may impair the useful life of the device.
Unless otherwise noted these limits are over the operating free air temperature range.)

SYMBOL	PARAMETER	RATING	UNIT
V _{CC}	Supply voltage	-0.5 to +7.0	V
V _{IN}	Input voltage	-0.5 to +7.0	V
I _{IN}	Input current	-30 to +5	mA
V _{OUT}	Voltage applied to output in high output state	-0.5 to V _{CC}	V
I _{OUT}	Current applied to output in low output state	40	mA
T _{amb}	Operating free air temperature range	0 to +70	°C
T _{stg}	Storage temperature range	-65 to +150	°C

RECOMMENDED OPERATING CONDITIONS

SYMBOL	PARAMETER	LIMITS			UNIT
		MIN	NOM	MAX	
V _{CC}	Supply voltage	4.5	5.0	5.5	V
V _{IH}	High-level input voltage	2.0			V
V _{IL}	Low-level input voltage			0.8	V
I _{IK}	Input clamp current			-18	mA
I _{OH}	High-level output current			-1	mA
I _{OL}	Low-level output current			20	mA
T _{amb}	Operating free air temperature range	0		+70	°C

DC ELECTRICAL CHARACTERISTICS

(Over recommended operating free-air temperature range unless otherwise noted.)

SYMBOL	PARAMETER	TEST CONDITIONS ¹	LIMITS			UNIT		
			MIN	TYP ²	MAX			
V _{OH}	High-level output voltage	V _{CC} = MIN, V _{IL} = MAX, V _{IH} = MIN	I _{OH} = -1mA	±10%V _{CC}	2.5		V	
				±5%V _{CC}	2.7	3.4	V	
			I _{OH} = -3mA	±10%V _{CC}	2.4		V	
				±5%V _{CC}	2.7	3.3	V	
V _{OL}	Low-level output voltage	V _{CC} = MIN, V _{IL} = MAX, V _{IH} = MIN	I _{OL} = MAX	±10%V _{CC}		0.30	0.50	V
				±5%V _{CC}		0.30	0.50	V
V _{IK}	Input clamp voltage	V _{CC} = MIN, I _I = I _{IK}			-0.73	-1.2	V	
I _I	Input current at maximum input voltage	V _{CC} = MAX, V _I = 7.0V				100	μA	
I _{IH}	High-level input current	V _{CC} = MAX, V _I = 2.7V				20	μA	
I _{IL}	Low-level input current	V _{CC} = MAX, V _I = 0.5V				-20	μA	
I _{OS}	Short-circuit output current ³	V _{CC} = MAX			-60	-150	mA	
I _{CC}	Supply current (total)	I _{CCH} I _{CCL}	V _{CC} = MAX			60	80	mA
						75	100	mA

Notes to DC electrical characteristics

- For conditions shown as MIN or MAX, use the appropriate value specified under recommended operating conditions for the applicable type.
- All typical values are at V_{CC} = 5V, T_{amb} = 25°C.
- Not more than one output should be shorted at a time. For testing I_{OS}, the use of high-speed test apparatus and/or sample-and-hold techniques are preferable in order to minimize internal heating and more accurately reflect operational values. Otherwise, prolonged shorting of a high output may raise the chip temperature well above normal and thereby cause invalid readings in other parameter tests. In any sequence of parameter tests, I_{OS} tests should be performed last.

Latch

74F1604

AC ELECTRICAL CHARACTERISTICS

SYMBOL	PARAMETER	TEST CONDITION	LIMITS					UNIT
			T _{amb} = +25°C V _{CC} = +5.0V C _L = 50pF, R _L = 500Ω			T _{amb} = 0°C to +70°C V _{CC} = +5.0V ± 10% C _L = 50pF, R = 500Ω		
			MIN	TYP	MAX	MIN	MAX	
t _{PLH} t _{PHL}	Propagation delay SELECT A/B̄ to Qn (non-inverting)	Waveform 2	3.0 3.5	5.5 6.5	8.5 10.0	2.5 3.0	9.0 11.5	ns
t _{PLH} t _{PHL}	Propagation delay SELECT A/B̄ to Qn (inverting)	Waveform 1	4.0 2.5	7.0 4.5	10.5 7.5	3.5 2.0	12.0 8.0	ns
t _{PLH} t _{PHL}	Propagation delay LĒ to Qn	Waveform 3	6.5 6.0	9.5 9.0	13.0 12.5	5.5 5.0	15.0 14.0	ns
t _{PLH} t _{PHL}	Propagation delay An or Bn to Qn	Waveform 1, 2	4.0 4.0	6.5 7.0	9.5 10.5	3.5 3.5	10.5 12.5	ns

AC SETUP REQUIREMENTS

SYMBOL	PARAMETER	TEST CONDITION	LIMITS					UNIT
			T _{amb} = +25°C V _{CC} = +5.0V C _D = 50pF, R _L = 500Ω			T _{amb} = 0°C to +70°C V _{CC} = +5.0V ± 10% C _D = 50pF, R _L = 500Ω		
			MIN	TYP	MAX	MIN	MAX	
t _{su} (H) t _{su} (L)	Setup time, high or low An, Bn to LĒ	Waveform 4	0.0 1.0			0.0 3.5		ns
t _h (H) t _h (L)	Hold time, high or low An, Bn to LĒ	Waveform 4	1.5 3.0			2.0 3.5		ns
t _w (L)	LĒ Pulse width, low	Waveform 4	6.5			7.5		ns

AC WAVEFORMS

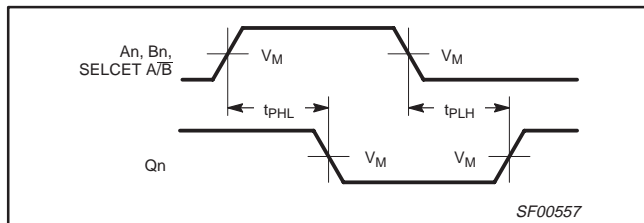

Waveform 1. Propagation delay for SELECT A/B̄ to output (A register stored data = low) or An, Bn to output

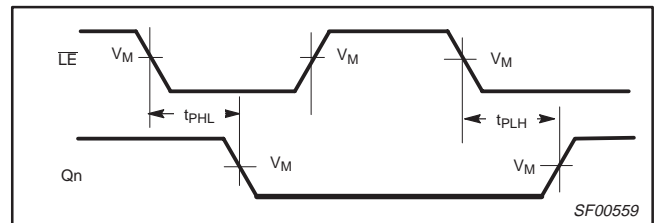

Waveform 3. Propagation delay for latch enable to output

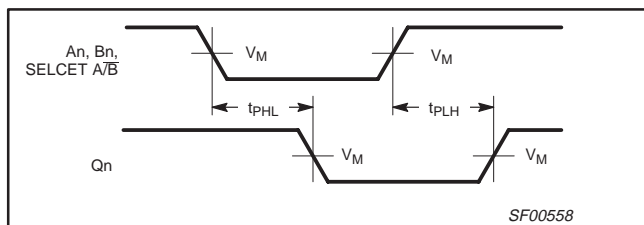

Waveform 2. Propagation delay for SELECT A/B̄ to output (A register stored data = low) or An, Bn to output

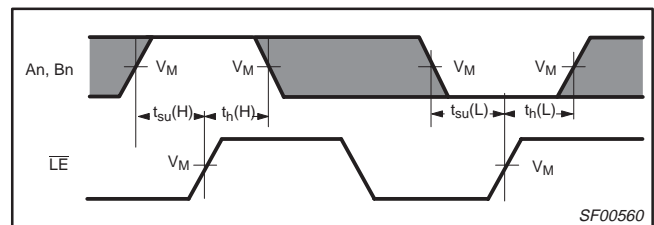

Waveform 4. Setup time and hold times and LĒ pulse width

Note to AC waveforms

For all waveforms, V_M = 1.5V.

The shaded areas indicate when the input is permitted to change for predictable output performance.

Latch

74F1604

TEST CIRCUIT AND WAVEFORMS

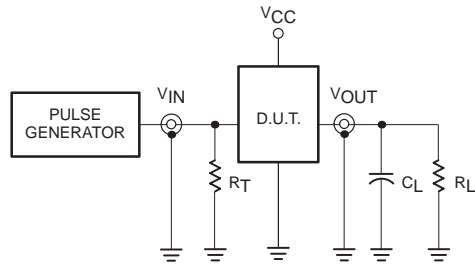

Test Circuit for Totem-Pole Outputs

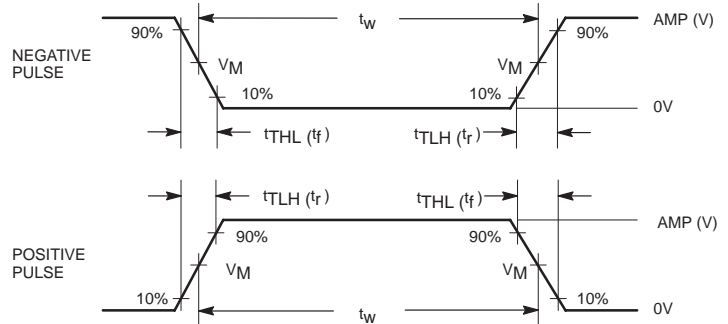

Input Pulse Definition

DEFINITIONS:

- R_L = Load resistor; see AC ELECTRICAL CHARACTERISTICS for value.
- C_L = Load capacitance includes jig and probe capacitance; see AC ELECTRICAL CHARACTERISTICS for value.
- R_T = Termination resistance should be equal to Z_{OUT} of pulse generators.

family	INPUT PULSE REQUIREMENTS					
	amplitude	V_M	rep. rate	t_w	t_{TLH}	t_{THL}
74F	3.0V	1.5V	1MHz	500ns	2.5ns	2.5ns

SF00006

Latch

74F1604

DIP28: plastic dual in-line package; 28 leads (600 mil); long body

SOT117-2

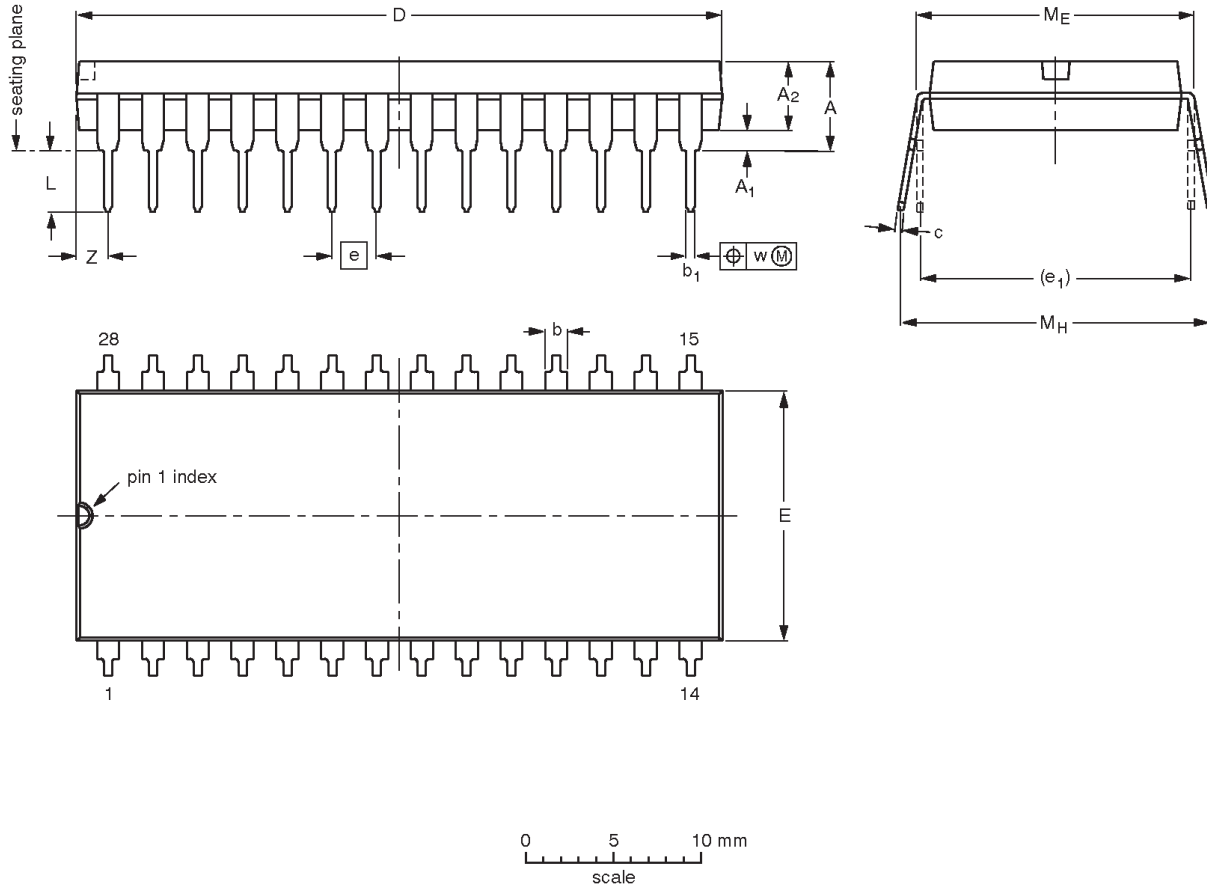

DIMENSIONS (millimetre dimensions are derived from the original inch dimensions)

UNIT	A max.	A ₁ min.	A ₂ max.	b	b ₁	c	D ⁽¹⁾	E ⁽¹⁾	e	e ₁	L	M _E	M _H	w	Z ⁽¹⁾ max.
mm	5.08	0.51	3.94	1.63 1.14	0.56 0.43	0.38 0.25	37.08 35.94	14.22 13.84	2.54	15.24	3.51 3.05	15.75 15.24	17.65 15.24	0.25	2.10
inches	0.200	0.020	0.155	0.064 0.045	0.022 0.017	0.015 0.010	1.460 1.415	0.560 0.545	0.100	0.600	0.138 0.120	0.62 0.60	0.695 0.600	0.01	0.083

Note

1. Plastic or metal protrusions of 0.01 inches maximum per side are not included.

OUTLINE VERSION	REFERENCES				EUROPEAN PROJECTION	ISSUE DATE
	IEC	JEDEC	EIAJ			
SOT117-2		MS-011AB				95-03-11

Latch

74F1604

SO28: plastic small outline package; 28 leads; body width 7.5mm

SOT136-1

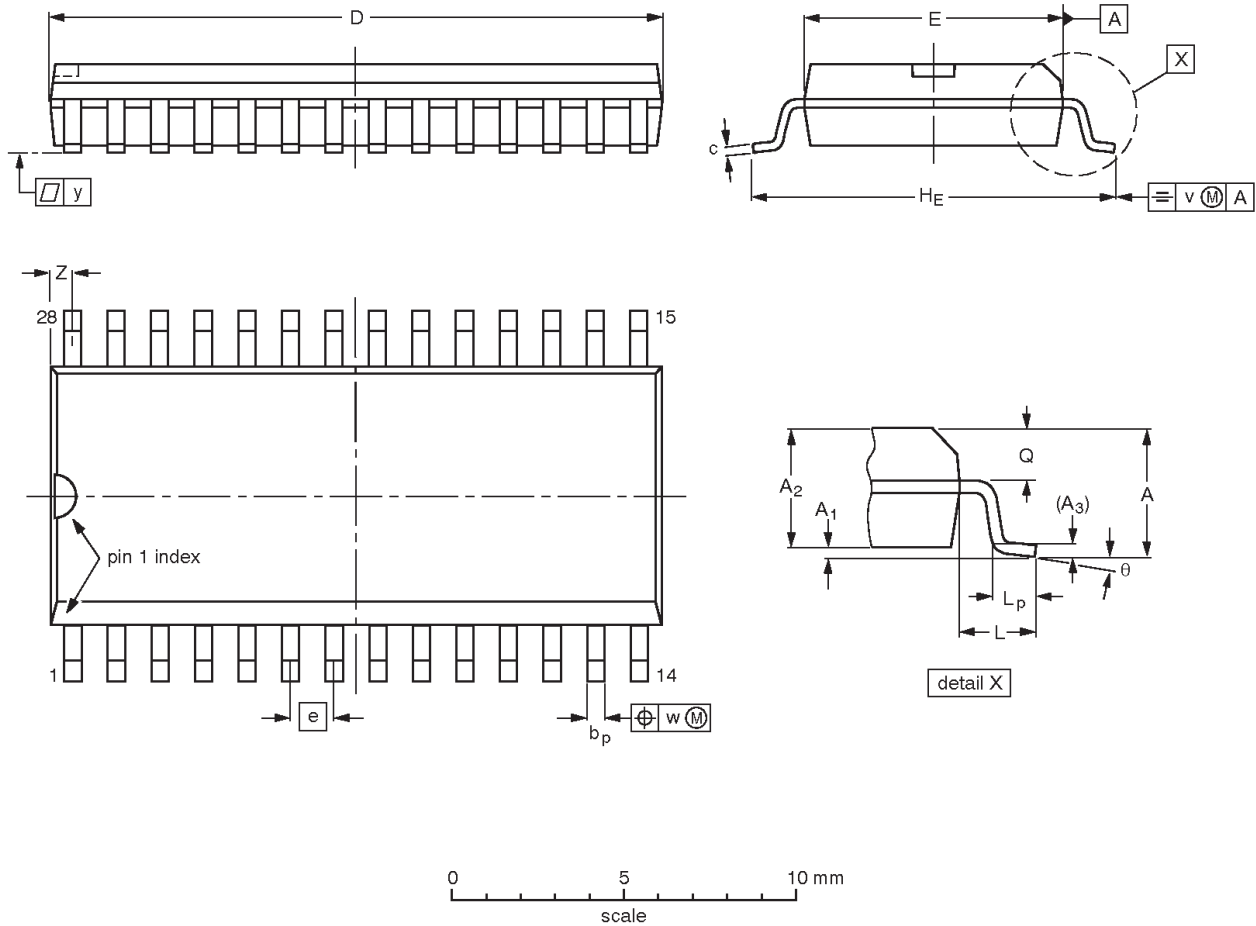

DIMENSIONS (inch dimensions are derived from the original mm dimensions)

UNIT	A max.	A ₁	A ₂	A ₃	b _p	c	D ⁽¹⁾	E ⁽¹⁾	e	H _E	L	L _p	Q	v	w	y	z ⁽¹⁾	θ
mm	2.65	0.30 0.10	2.45 2.25	0.25	0.49 0.36	0.32 0.23	18.1 17.7	7.6 7.4	1.27	10.65 10.00	1.4	1.1 0.4	1.1 1.0	0.25	0.25	0.1	0.9 0.4	8° 0°
inches	0.10	0.012 0.004	0.096 0.089	0.01	0.019 0.014	0.013 0.009	0.71 0.69	0.30 0.29	0.050	0.419 0.394	0.055	0.043 0.016	0.043 0.039	0.01	0.01	0.004	0.035 0.016	

Note

1. Plastic or metal protrusions of 0.15 mm maximum per side are not included.

OUTLINE VERSION	REFERENCES				EUROPEAN PROJECTION	ISSUE DATE
	IEC	JEDEC	EIAJ			
SOT136-1	075E06	MS-013AE				95-01-24 97-05-22

Latch

74F1604

NOTES

Latch

74F1604

Data sheet status

Data sheet status	Product status	Definition [1]
Objective specification	Development	This data sheet contains the design target or goal specifications for product development. Specification may change in any manner without notice.
Preliminary specification	Qualification	This data sheet contains preliminary data, and supplementary data will be published at a later date. Philips Semiconductors reserves the right to make changes at any time without notice in order to improve design and supply the best possible product.
Product specification	Production	This data sheet contains final specifications. Philips Semiconductors reserves the right to make changes at any time without notice in order to improve design and supply the best possible product.

[1] Please consult the most recently issued datasheet before initiating or completing a design.

Definitions

Short-form specification — The data in a short-form specification is extracted from a full data sheet with the same type number and title. For detailed information see the relevant data sheet or data handbook.

Limiting values definition — Limiting values given are in accordance with the Absolute Maximum Rating System (IEC 134). Stress above one or more of the limiting values may cause permanent damage to the device. These are stress ratings only and operation of the device at these or at any other conditions above those given in the Characteristics sections of the specification is not implied. Exposure to limiting values for extended periods may affect device reliability.

Application information — Applications that are described herein for any of these products are for illustrative purposes only. Philips Semiconductors make no representation or warranty that such applications will be suitable for the specified use without further testing or modification.

Disclaimers

Life support — These products are not designed for use in life support appliances, devices or systems where malfunction of these products can reasonably be expected to result in personal injury. Philips Semiconductors customers using or selling these products for use in such applications do so at their own risk and agree to fully indemnify Philips Semiconductors for any damages resulting from such application.

Right to make changes — Philips Semiconductors reserves the right to make changes, without notice, in the products, including circuits, standard cells, and/or software, described or contained herein in order to improve design and/or performance. Philips Semiconductors assumes no responsibility or liability for the use of any of these products, conveys no license or title under any patent, copyright, or mask work right to these products, and makes no representations or warranties that these products are free from patent, copyright, or mask work right infringement, unless otherwise specified.

Philips Semiconductors
811 East Arques Avenue
P.O. Box 3409
Sunnyvale, California 94088-3409
Telephone 800-234-7381

© Copyright Philips Electronics North America Corporation 1998
All rights reserved. Printed in U.S.A.

print code

Date of release: 10-98

Document order number:

9397-750-05194

Let's make things better.



LittleDiode supplies new, hard to find or obsolete electronic components and semiconductors all over the world.

With over two million different components listed you are sure to find the part you need.

Feel free to visit us today at our online store:

LittleDiode.com

Looking forward to providing you with the best possible service.