

DATA SHEET

74F30244

Octal 30Ω line driver with enable,
non-inverting (open collector)

Product specification
Supersedes data of 1999 Jan 08
IC15 Data Handbook

2000 Jun 30

Octal 30Ω line driver with enable, non-inverting (open collector)

74F30244

FEATURES

- Ideal for driving transmission lines or backplanes. 160mA I_{OL} ideal for applications with impedance as low as 30Ω
- Guaranteed threshold voltages on the incident wave while driving line as low as 30Ω
- High impedance NPN base inputs for reduced loading (20μA in High and Low states)
- Ideal for applications which require high output drive and minimal bus loading
- Octal interface
- Non-inverting
- Open-Collector outputs sink 160mA
- Multiple side pins are used for V_{CC} and GND to reduce lead inductance (improves speed and noise immunity)
- Available in 24-pin standard slim DIP (300mil) plastic or SOL

DESCRIPTION

The 74F30244 is a high current open collector octal buffer composed of eight inverters. The 74F30244 has non-inverting paths. The device has eight inverters with two Output Enables ($\overline{OE}0$, $\overline{OE}1$), each controlling four outputs. The driver is designed to deal with the low-impedance transmission line effects found on printed circuit boards when fast edge rates are used. The 160mA I_{OL} provides ample power to achieve TTL switching voltages on the incident wave.

TYPE	TYPICAL PROPAGATION DELAY	TYPICAL SUPPLY CURRENT (TOTAL)
74F30244	10.5ns	69mA

ORDERING INFORMATION

DESCRIPTION	COMMERCIAL RANGE $V_{CC} = 5V \pm 10\%$, $T_{amb} = 0^{\circ}C$ to $+70^{\circ}C$	PACKAGE DRAWING NUMBER
24-pin Plastic Slim DIP (300mil)	N74F30244N	SOT222-1
24-pin Plastic SOL ¹	N74F30244D	SOT137-1

NOTE:

1. Because of the high current sinking capability of these parts, the SOL package should only be used under the following conditions:
 - a. 50% duty cycle,
 AND
 - b. 3/5 of remaining 50% driving $\leq 100mA$ (leaving the remaining 2/5 of the drive $\leq 160mA$)
 OR
 - c. use ≤ 450 linear feet per minute forced air or other thermal mounting techniques.

INPUT AND OUTPUT LOADING AND FAN-OUT TABLE

PINS	DESCRIPTION	74F(U.L.) HIGH/LOW	LOAD VALUE HIGH/LOW
D0–D7	Data inputs	1.0/0.033	20μA/20μA
$\overline{OE}0$ – $\overline{OE}1$	Output Enable inputs (Active Low)	1.0/0.033	20μA/20μA
Q0–Q7	Data outputs (OC)	OC/266.7	OC/160mA

NOTE: One (1.0) FAST unit load is defined as: 20μA in the High state and 0.6mA in the Low state. OC = Open Collector.

Octal 30Ω line driver with enable, non-inverting (open collector)

74F30244

PIN CONFIGURATION

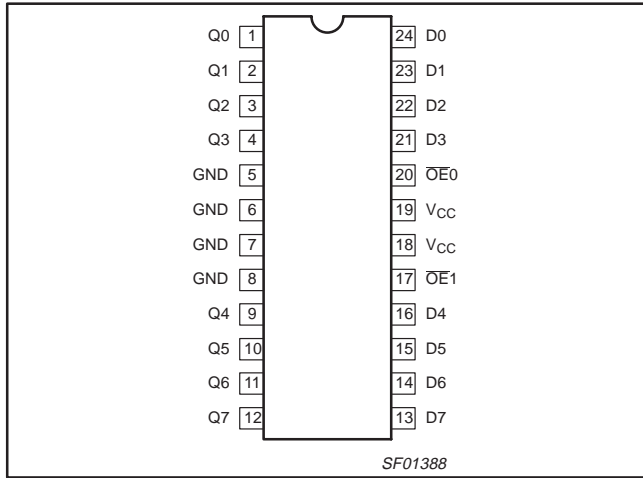

LOGIC DIAGRAM

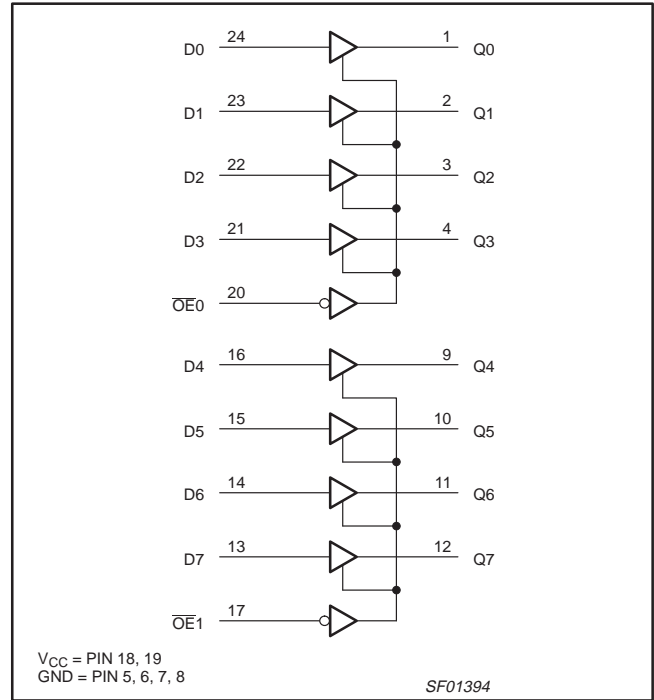

LOGIC SYMBOL

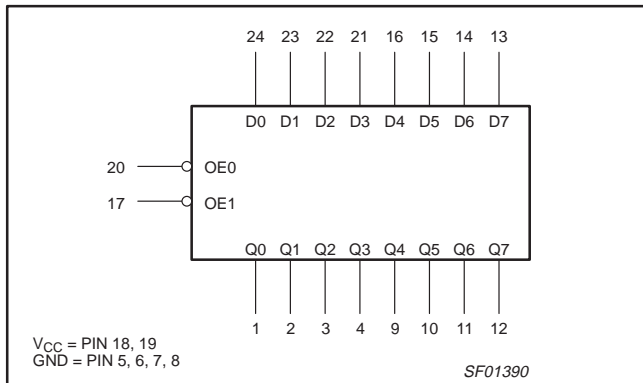

IEC/IEEE SYMBOL

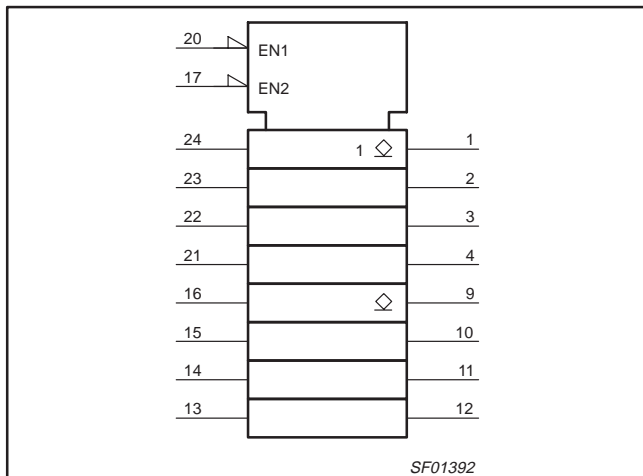

Octal 30Ω line driver with enable, non-inverting (open collector)

74F30244

FUNCTION TABLE

INPUTS		OUTPUTS
\overline{OEn}	Dn	Qn
L	L	L
L	H	H
H	X	OFF

H = High voltage level

L = Low voltage level

X = Don't care

OFF = Pulled up through resistor (Open Collector)

ABSOLUTE MAXIMUM RATINGS

(Operation beyond the limits set forth in this table may impair the useful life of the device.

Unless otherwise noted these limits are over the operating free-air temperature range.)

SYMBOL	PARAMETER	RATING	UNIT
V_{CC}	Supply voltage	-0.5 to +7.0	V
V_{IN}	Input voltage	-0.5 to +7.0	V
I_{IN}	Input current	-30 to +5	mA
V_{OUT}	Voltage applied to output in High output state	-0.5 to V_{CC}	V
I_{OUT}	Current applied to output in Low output state	320	mA
T_{amb}	Operating free-air temperature range	0 to +70	°C
T_{stg}	Storage temperature range	-65 to +150	°C

RECOMMENDED OPERATING CONDITIONS

SYMBOL	PARAMETER	LIMITS			UNIT
		MIN	NOM	MAX	
V_{CC}	Supply voltage	4.5	5.0	5.5	V
V_{IH}	High-level input voltage	2.0			V
V_{IL}	Low-level input voltage			0.8	V
I_{IK}	Input clamp current			-18	mA
V_{OH}	High-level output voltage			4.5	V
I_{OL}	Low-level output current			160	mA
T_{amb}	Operating free-air temperature range	0		+70	°C

Octal 30Ω line driver with enable, non-inverting (open collector)

74F30244

DC ELECTRICAL CHARACTERISTICS

(Over recommended operating free-air temperature range unless otherwise noted.)

SYMBOL	PARAMETER		TEST CONDITIONS ¹		LIMITS			UNIT	
					MIN	TYP ²	MAX		
I _{OH}	High-level output current		V _{CC} = MIN, V _{IL} = MAX, V _{IH} = MIN, V _{OH} = MAX				250	μA	
V _{OL}	Low-level output current		V _{CC} = MIN, V _{IL} = MAX, V _{IH} = MIN	I _{OL} = 100mA	±10% V _{CC}		0.42	0.55	V
				I _{OL} = 160mA ³	±5% V _{CC}			0.80	V
V _{IK}	Input clamp voltage		V _{CC} = MIN, I _I = I _{IK}			-0.73	-1.2	V	
I _I	Input current at maximum input voltage		V _{CC} = 0.0V, V _I = 7.0V				100	μA	
I _{IH}	High-level input current		V _{CC} = MAX, V _I = 2.7V				20	μA	
I _{IL}	Low-level input current		V _{CC} = MAX, V _I = 0.5V				-20	μA	
I _{CC}	Supply current (total)	74F30244	V _{CC} = MAX		I _{CCH}		19	27	mA
					I _{CCL}		70	100	mA

NOTES:

- For conditions shown as MIN or MAX, use the appropriate value specified under recommended operating conditions for the applicable type.
- All typical values are at V_{CC} = 5V, T_{amb} = 25°C.
- I_{OL1} is the current necessary to guarantee the High-to-Low transition in a 30Ω transmission line on the incident wave.

AC ELECTRICAL CHARACTERISTICS

SYMBOL	PARAMETER	TEST CONDITION	LIMITS					UNIT
			T _{amb} = +25°C V _{CC} = +5.0V C _L = 50pF, R _L = 500Ω			T _{amb} = 0°C to +70°C V _{CC} = +5.0V ± 10% C _L = 50pF, R _L = 500Ω		
			MIN	TYP	MAX	MIN	MAX	
t _{PLH} t _{PHL}	Propagation delay Dn to Qn	Waveform 1	4.0 3.0	10.5 5.5	14.5 9.0	4.0 3.0	15.0 9.5	ns
t _{PLH} t _{PHL}	Propagation delay OEn to Qn	Waveform 1, 2	4.0 3.5	9.5 6.0	14.0 9.0	4.0 3.5	14.5 10.5	ns

AC WAVEFORMS

For all waveforms, V_M = 1.5V.

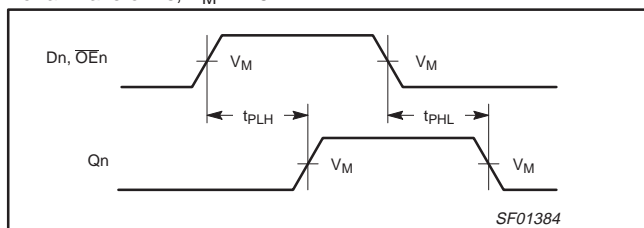

Waveform 1. Propagation Delay for Data to Output

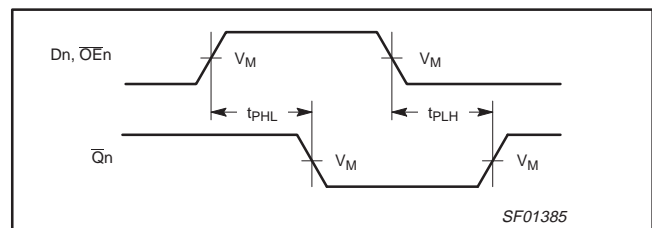

Waveform 2. Propagation Delay for Data to Output

Octal 30Ω line driver with enable, non-inverting (open collector)

74F30244

TYPICAL PROPAGATION DELAYS VERSUS LOAD FOR OPEN COLLECTOR OUTPUTS

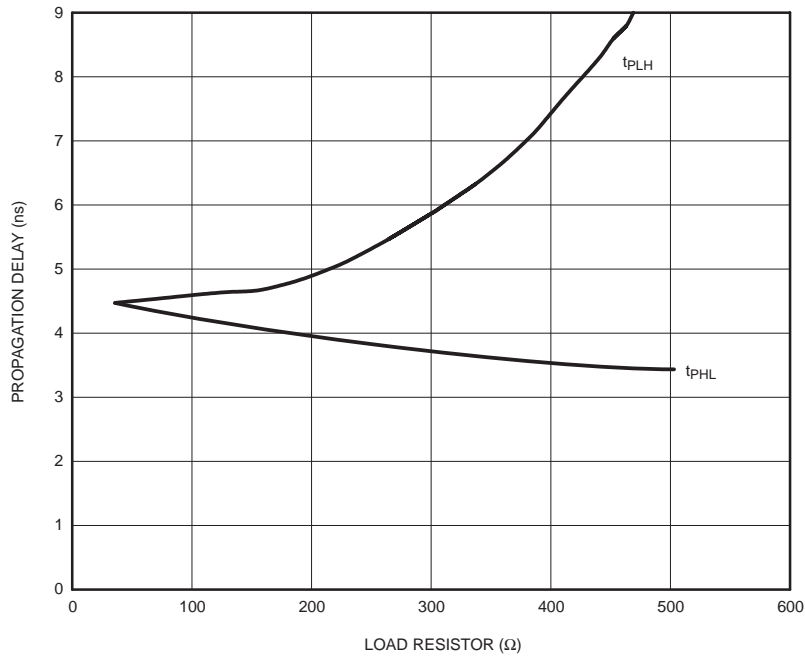

NOTE:

When using Open-Collector parts, the value of the pull-up resistor greatly affects the value of the t_{PLH}. For example, changing the specified pull-up resistor value from 500Ω to 100Ω will improve the t_{PLH} up to 50% with only a slight increase in the t_{PHL}. However, if the value of the pull-up resistor is changed, the user must make certain that the total I_{OL} current through the resistor and the total I_{IL}s of the receivers does not exceed the I_{OL} maximum specification.

SF01386

TEST CIRCUIT AND WAVEFORMS

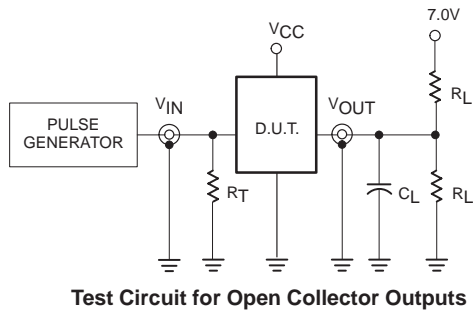

Test Circuit for Open Collector Outputs

DEFINITIONS:

- R_L = Load resistor; see AC electrical characteristics for value.
- C_L = Load capacitance includes jig and probe capacitance; see AC electrical characteristics for value.
- R_T = Termination resistance should be equal to Z_{OUT} of pulse generators.

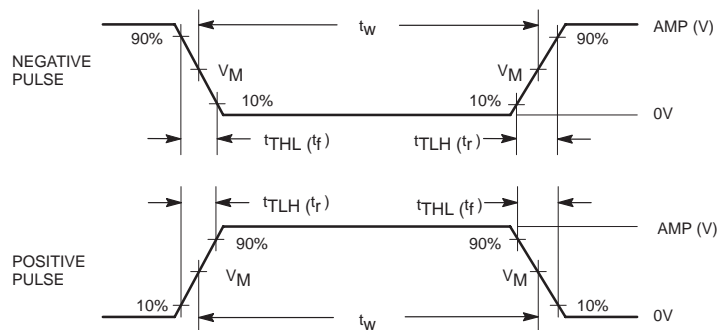

Input Pulse Definition

family	INPUT PULSE REQUIREMENTS					
	amplitude	V _M	rep. rate	t _w	t _{TLH}	t _{THL}
74F	3.0V	1.5V	1MHz	500ns	2.5ns	2.5ns

SF00027

Octal 30Ω line driver with enable, non-inverting (open collector)

74F30244

SO24: plastic small outline package; 24 leads; body width 7.5 mm

SOT137-1

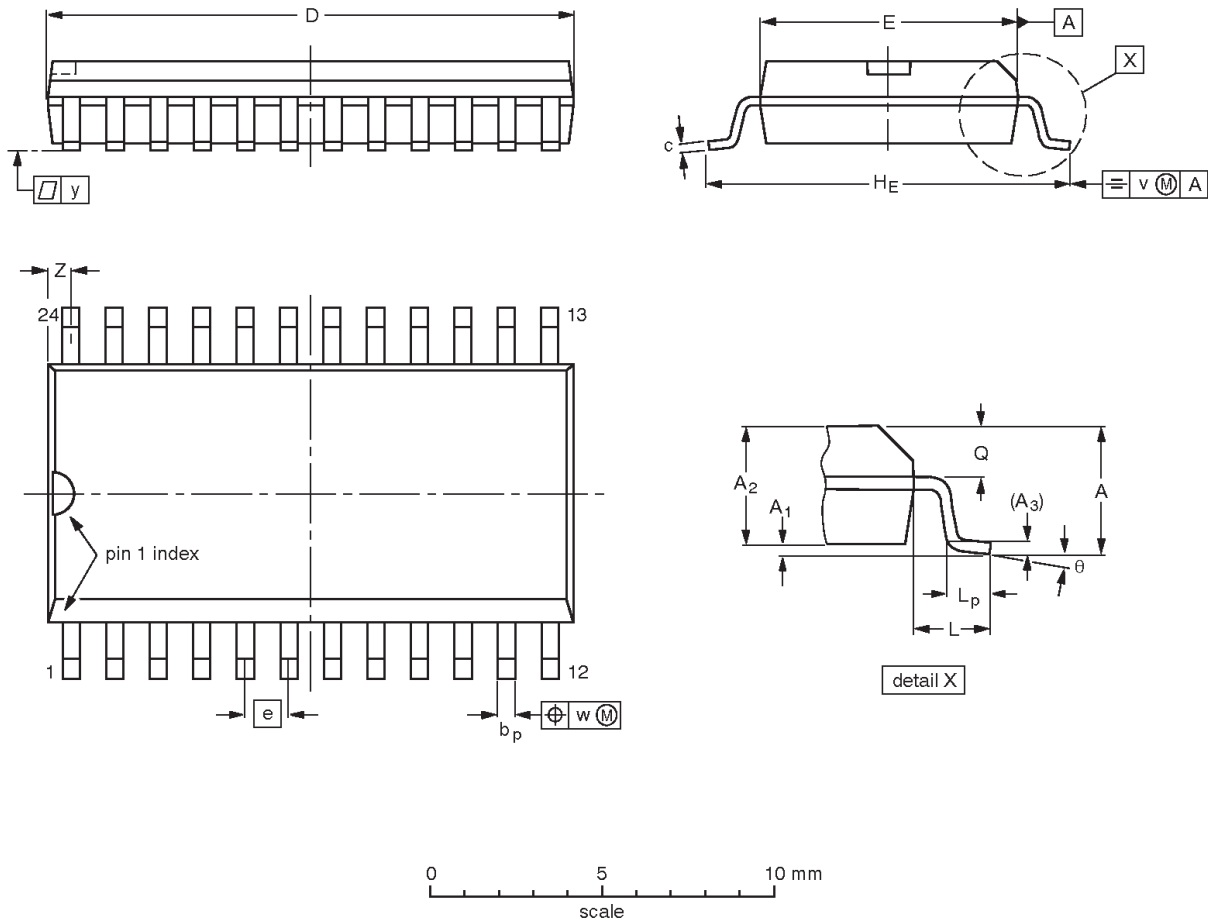

DIMENSIONS (inch dimensions are derived from the original mm dimensions)

UNIT	A max.	A ₁	A ₂	A ₃	b _p	c	D ⁽¹⁾	E ⁽¹⁾	e	H _E	L	L _p	Q	v	w	y	z ⁽¹⁾	θ
mm	2.65	0.30 0.10	2.45 2.25	0.25	0.49 0.36	0.32 0.23	15.6 15.2	7.6 7.4	1.27	10.65 10.00	1.4	1.1 0.4	1.1 1.0	0.25	0.25	0.1	0.9 0.4	8° 0°
inches	0.10	0.012 0.004	0.096 0.089	0.01	0.019 0.014	0.013 0.009	0.61 0.60	0.30 0.29	0.050	0.419 0.394	0.055	0.043 0.016	0.043 0.039	0.01	0.01	0.004	0.035 0.016	

Note

1. Plastic or metal protrusions of 0.15 mm maximum per side are not included.

OUTLINE VERSION	REFERENCES				EUROPEAN PROJECTION	ISSUE DATE
	IEC	JEDEC	EIAJ			
SOT137-1	075E05	MS-013AD				95-01-24 97-05-22

Octal 30Ω line driver with enable, non-inverting
(open collector)

74F30244

NOTES

Octal 30Ω line driver with enable, non-inverting (open collector)

74F30244

Data sheet status

Data sheet status	Product status	Definition [1]
Objective specification	Development	This data sheet contains the design target or goal specifications for product development. Specification may change in any manner without notice.
Preliminary specification	Qualification	This data sheet contains preliminary data, and supplementary data will be published at a later date. Philips Semiconductors reserves the right to make changes at any time without notice in order to improve design and supply the best possible product.
Product specification	Production	This data sheet contains final specifications. Philips Semiconductors reserves the right to make changes at any time without notice in order to improve design and supply the best possible product.

[1] Please consult the most recently issued datasheet before initiating or completing a design.

Definitions

Short-form specification — The data in a short-form specification is extracted from a full data sheet with the same type number and title. For detailed information see the relevant data sheet or data handbook.

Limiting values definition — Limiting values given are in accordance with the Absolute Maximum Rating System (IEC 134). Stress above one or more of the limiting values may cause permanent damage to the device. These are stress ratings only and operation of the device at these or at any other conditions above those given in the Characteristics sections of the specification is not implied. Exposure to limiting values for extended periods may affect device reliability.

Application information — Applications that are described herein for any of these products are for illustrative purposes only. Philips Semiconductors make no representation or warranty that such applications will be suitable for the specified use without further testing or modification.

Disclaimers

Life support — These products are not designed for use in life support appliances, devices or systems where malfunction of these products can reasonably be expected to result in personal injury. Philips Semiconductors customers using or selling these products for use in such applications do so at their own risk and agree to fully indemnify Philips Semiconductors for any damages resulting from such application.

Right to make changes — Philips Semiconductors reserves the right to make changes, without notice, in the products, including circuits, standard cells, and/or software, described or contained herein in order to improve design and/or performance. Philips Semiconductors assumes no responsibility or liability for the use of any of these products, conveys no license or title under any patent, copyright, or mask work right to these products, and makes no representations or warranties that these products are free from patent, copyright, or mask work right infringement, unless otherwise specified.

Philips Semiconductors
811 East Arques Avenue
P.O. Box 3409
Sunnyvale, California 94088-3409
Telephone 800-234-7381

© Copyright Philips Electronics North America Corporation 2000
All rights reserved. Printed in U.S.A.

Date of release: 06-00

Document order number:

9397-750 07281

Let's make things better.



LittleDiode supplies new, hard to find or obsolete electronic components and semiconductors all over the world.

With over two million different components listed you are sure to find the part you need.

Feel free to visit us today at our online store:

LittleDiode.com

Looking forward to providing you with the best possible service.