

DATA SHEET

74F5302

Fiber optic dual LED/clock driver

Product specification

1990 Jul 24

IC15 Data Handbook

Fiber optic dual LED/clock driver

74F5302

FEATURES

- TTL inputs
- Output enable control
- High current source and sink capability
- Matched propagation delay times (t_{PLH} , t_{PHL})
- Symmetrical rise and fall times
- ESD protection greater than 2000 volts
- Single +5V supply
- Surface mount package

APPLICATIONS

- High speed serial data communication
- Fiber optic data links
- Local area and metropolitan area networks
- Digital Television
- PBX systems

ASSOCIATED PRODUCTS

- NE5210/11/12 transimpedance amplifiers
- NE5214/5217 postamplifiers with link status indicator
- 74F5300 fiber optic LED driver

TYPE	TYPICAL PROPAGATION DELAY	TYPICAL SUPPLY CURRENT(TOTAL)
74F5302	2.5ns	8mA

ORDERING INFORMATION

DESCRIPTION	ORDER CODE	
	COMMERCIAL RANGE $V_{CC} = 5V \pm 10\%$, $T_{amb} = 0^{\circ}C$ to $+70^{\circ}C$	PKG DWG #
14-pin plastic DIP	N74F5302N	SOT27-1
14-pin plastic SO	N74F5302D	SOT108-1

INPUT AND OUTPUT LOADING AND FAN OUT TABLE

PINS	DESCRIPTION	74F (U.L.) HIGH/LOW	LOAD VALUE HIGH/LOW
Dn	Data inputs	1.0/1.0	20 μ A/0.6mA
En	Enable inputs	1.0/1.0	20 μ A/0.6mA
Qn	Current driver output	8000/266.6	160mA/160mA

NOTE: One (1.0) FAST unit load is defined as: 20 μ A in the high state and 0.6mA in the low state.

PIN CONFIGURATION

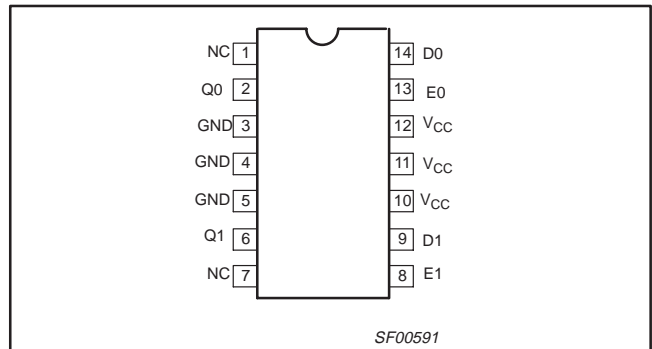

LOGIC DIAGRAM (ONE DRIVER)

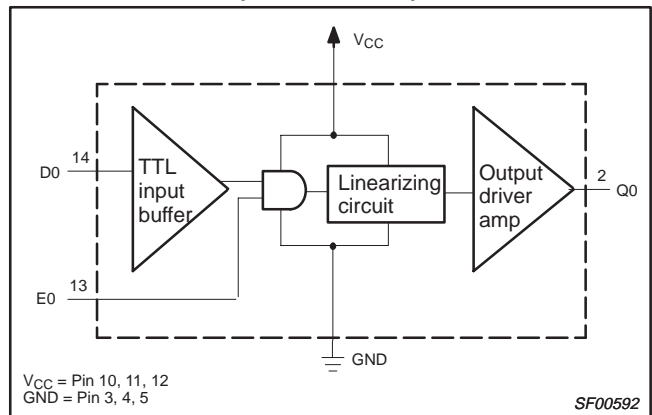

DESCRIPTION

The 74F5302 is a dual LED/clock driver designed for use in fiber optic links. The 74F5302 is ideally suited for use in high speed optical high transmitter systems. It is also ideal for use as a clock driver.

The TTL input buffer accepts TTL data. The linearizing circuits ensures a constant propagation delay for t_{PLH} and t_{PHL} , and controls the rise and fall times. The output driver amplifier is capable of sourcing more than 160mA and sinking more than 160mA at low impedances. The high current output driver has been designed to deal with transmission line effects of high speed switching systems with fast rising and falling edges. The performance of the system can be enhanced by matching impedance at the output for proper termination. It exhibits closely matched propagation delays (t_{PLH} and t_{PHL}) and symmetrical rise and fall times. The resulting optical waveform has minimal duty cycle distortion (DCD). When used with the external pre-bias and pre-charging circuits, the response can be tailored to a specific LED to eliminate any overshoot and to minimize the long fall response.

Additionally, this part can be used as the transmitter in a complete fiber optic system when combined with any of the NE5210/5211/5212 preamplifiers and NE5214/5217 postamplifiers for the optical receiver. Please refer to applications note AN1121 in the Philips Semiconductors Fiber Optic Communication Data Book for more specific applications information.

Fiber optic dual LED/clock driver

74F5302

APPLICATION FOR 50Mb/s OPTICAL TRANSMITTER

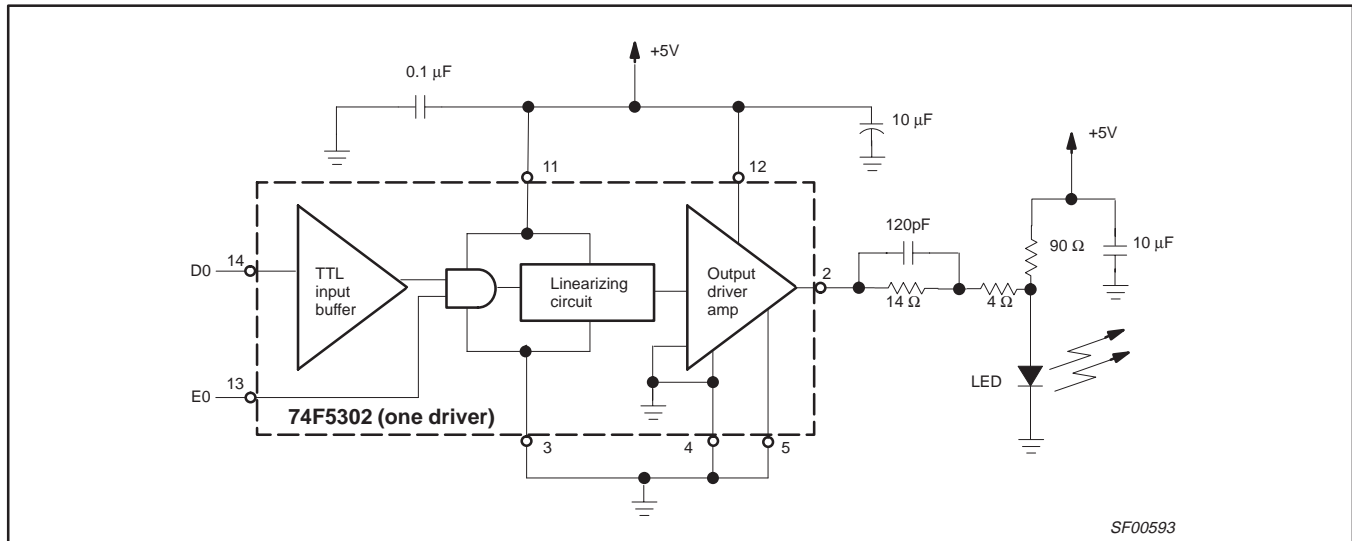

ABSOLUTE MAXIMUM RATINGS

(Operation beyond the limit set forth in this table may impair the useful life of the device. Unless otherwise noted these limits are over the operating free air temperature range.)

SYMBOL	PARAMETER	RATING	UNIT
V _{CC}	Supply voltage	-0.5 to +7.0	V
V _{IN}	Input voltage	-0.5 to +7.0	V
I _{IN}	Input current	-30 to +5	mA
V _{OUT}	Voltage applied to output in high output state	-0.5 to V _{CC}	V
I _{OUT}	Current applied to output in low output state	240	mA
T _{amb}	Operating free air temperature range	0 to +70	°C
T _{stg}	Storage temperature range	-65 to +150	°C

RECOMMENDED OPERATING CONDITIONS

SYMBOL	PARAMETER	LIMITS			T _A = -40 to +85°C
		MIN	NOM	MAX	UNIT
V _{CC}	Supply voltage	4.5	5.0	5.5	V
V _{IH}	High-level input voltage	2.0			V
V _{IL}	Low-level input voltage			0.8	V
I _{Ik}	Input clamp current			-18	mA
I _{OH}	High-level output current			-160	mA
I _{OL}	Low-level output current			160	mA
T _{amb}	Operating free air temperature range	0		+70	°C

Fiber optic dual LED/clock driver

74F5302

DC ELECTRICAL CHARACTERISTICS

(Over recommended operating free-air temperature range unless otherwise noted.)

SYMBOL	PARAMETER	TEST CONDITIONS ¹			LIMITS			UNIT	
					MIN	TYP ²	MAX		
V _{OH}	High-level output voltage	V _{CC} = MIN, V _{IL} = MAX, V _{IH} = MIN	I _{OH} = -80mA	±10%V _{CC}	2.5			V	
				±5%V _{CC}	2.8	3.3	3.9	V	
				V _{CC} = 5V	3.0	3.3	3.6	V	
			I _{OH} = -160mA	±10%V _{CC}	2.0			V	
V _{OL}	Low-level output voltage	V _{CC} = MIN, V _{IL} = MAX, V _{IH} = MIN	I _{OL} = 100mA	±10%V _{CC}		0.42	0.55	V	
			I _{OL} = 120mA	±10%V _{CC}		0.45	0.60	V	
			I _{OL} = 160mA	±10%V _{CC}		0.55	0.80	V	
V _{IK}	Input clamp voltage	V _{CC} = MIN, I _I = I _{IK}				-0.73	-1.2	V	
I _I	Input current at maximum input voltage	V _{CC} = MAX, V _I = 7.0V					100	μA	
I _{IH}	High-level input current	V _{CC} = MAX, V _I = 2.7V					20	μA	
I _{IL}	Low-level input current	V _{CC} = MAX, V _I = 0.5V					-0.6	mA	
I _{CC}	Supply current (total)	I _{CCH}	V _{CC} = MAX				5.0	12	mA
		I _{CCL}	V _{CC} = MAX				18	25	mA

NOTES:

1. For conditions shown as MIN or MAX, use the appropriate value specified under recommended operating conditions for the applicable type.
2. All typical values are at V_{CC} = 5V, T_{amb} = 25°C.
3. The device is not short circuit protected.

AC ELECTRICAL CHARACTERISTICS

SYMBOL	PARAMETER	TEST CONDITION	LIMITS					UNIT
			T _{amb} = +25°C V _{CC} = +5.0V C _L = 50pF, R _L = 100Ω			T _{amb} = 0°C to +70°C V _{CC} = +5.0V ± 10% C _L = 50pF, R _L = 100Ω		
			MIN	TYP	MAX	MIN	MAX	
t _{PLH} t _{PHL}	Propagation delay D _n , E _n to Q _n	Waveform 1	1.0 1.0	2.0 2.5	4.5 5.0	1.0 1.0	4.5 5.0	ns
D _{tpw}	Pulse width distortion ¹	Frequency = 10MHz		0.8	1.2		1.8	ns
t _{RFS}	Rise and fall time skew ^{3, 4}			0.3	1.5		2.0	ns
t _{sk (0)}	Output skew ^{2, 4}	Waveform 2		0.9	1.3		1.6	ns
t _{THL} t _{TLH}	Fall time 90% to 10% Rise time 10% to 90%	Test circuits and Waveforms	1.0 1.0	1.5 1.8	3.0 3.0	0.5 0.5	4.0 4.5	ns

NOTES:

1. D_{tpw} is defined as the difference between input pulse width and output pulse width (0 to 3 volt swing and 50% duty cycle).
2. |t_{pN} actual - t_{pM} actual| for any output compared to any other output where N and M are either LH or HL.
3. |t_{TLH} actual - t_{THL} actual|.
4. Skew times are valid only under same test conditions (temperature, V_{CC}, loading, etc.).

AC WAVEFORMS

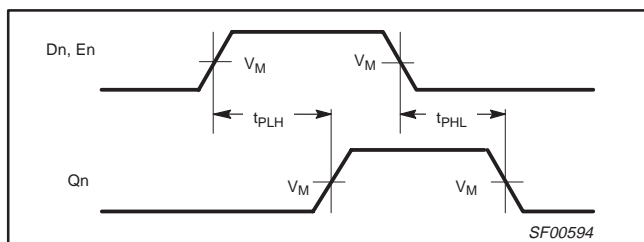

Waveform 1. Propagation delay for input to output

NOTE: For all waveforms, V_M = 1.5V.

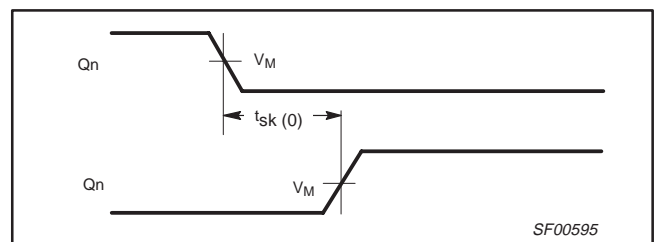

Waveform 2. Output skew

Fiber optic dual LED/clock driver

74F5302

TYPICAL ($V_{CC} = 5.0V$) V_{OL} VERSUS I_{OL} FOR VARIOUS TEMPERATURES

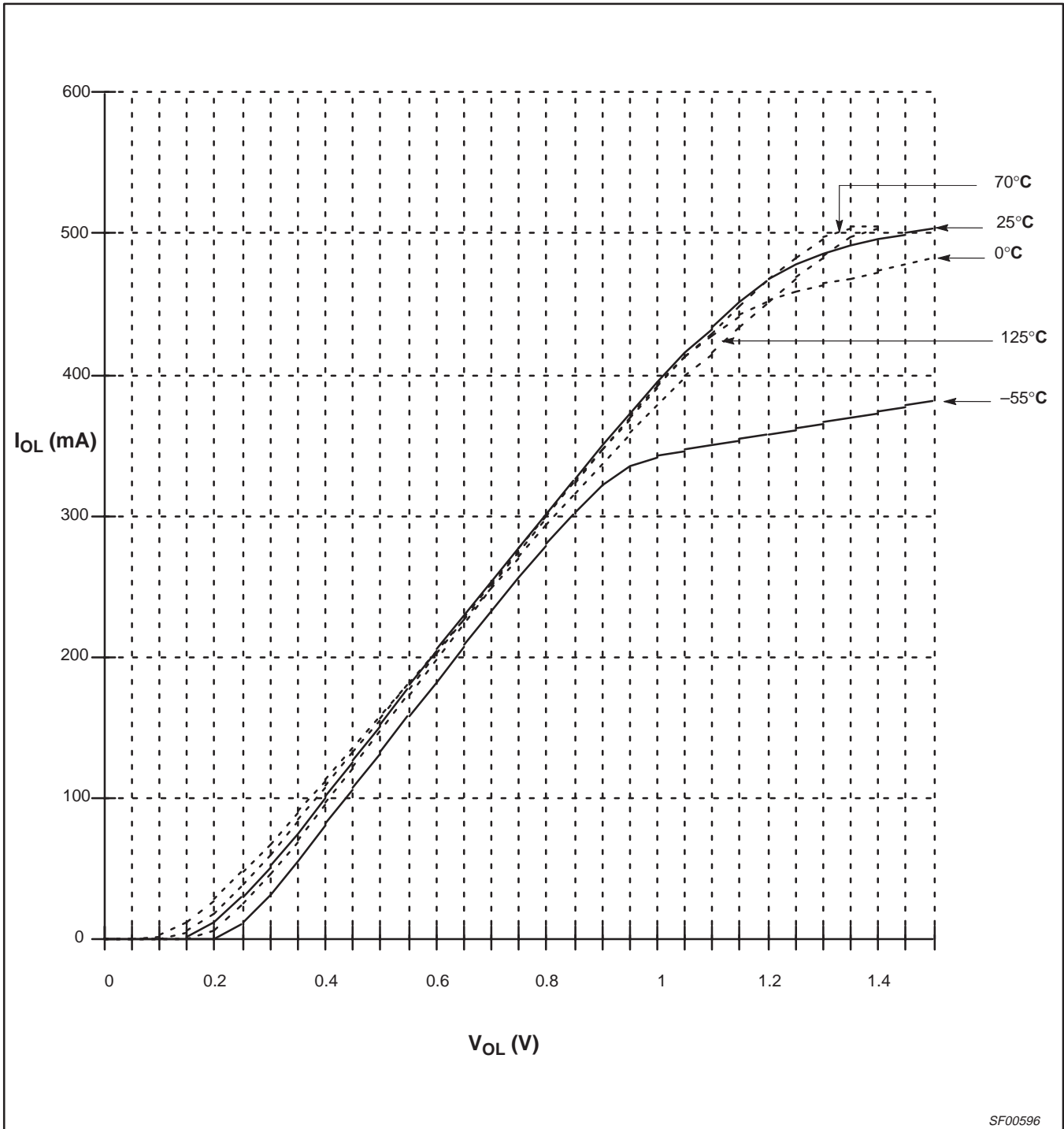

SF00596

Fiber optic dual LED/clock driver

74F5302

TYPICAL ($V_{CC} = 5.0V$) V_{OH} VERSUS I_{OH} FOR VARIOUS TEMPERATURES

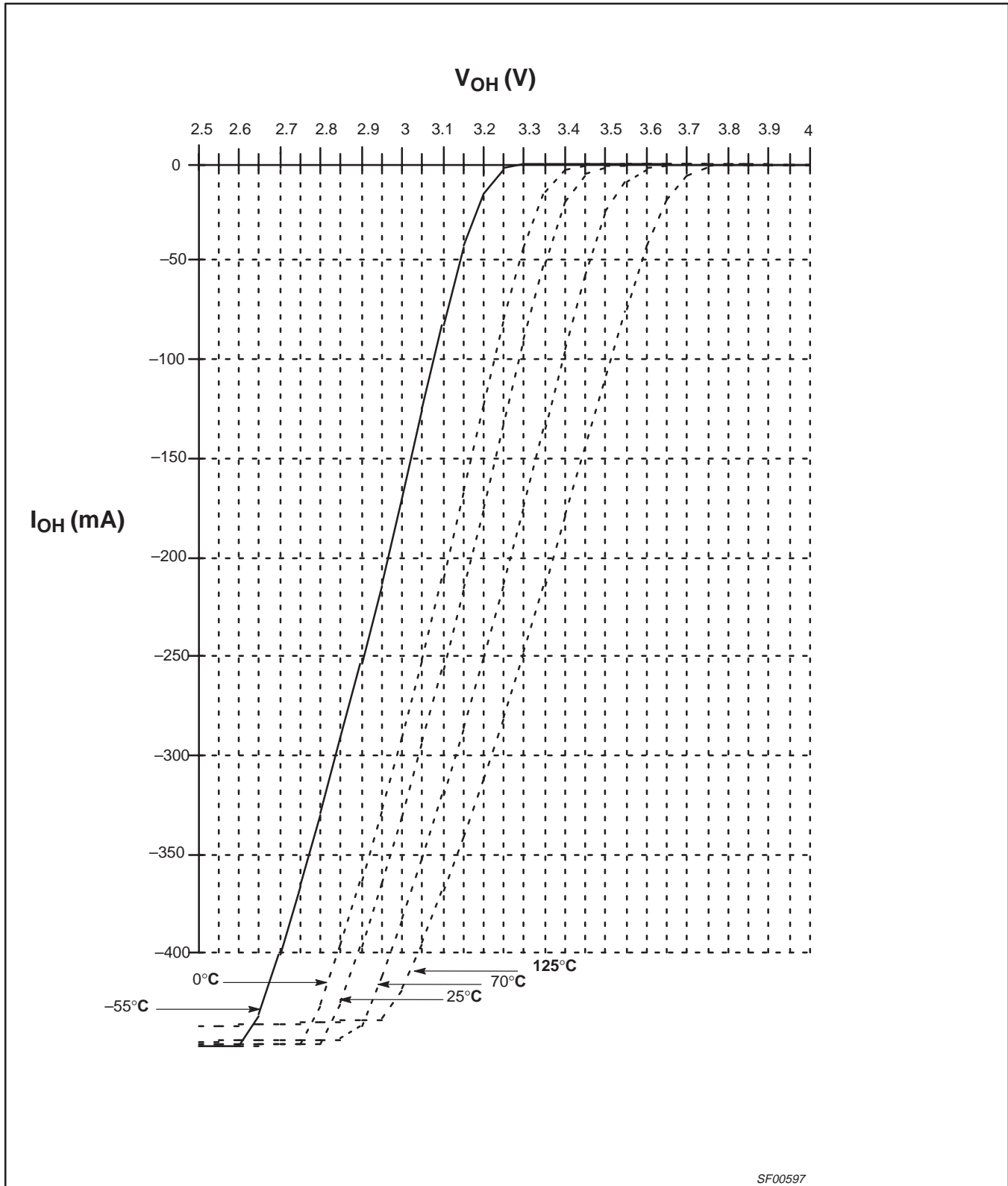

SF00597

Fiber optic dual LED/clock driver

74F5302

TEST CIRCUIT AND WAVEFORMS

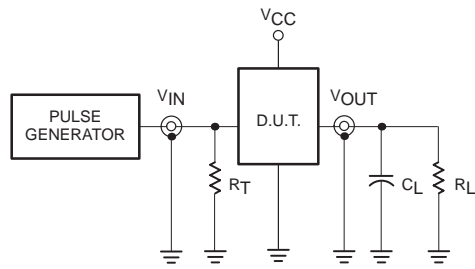

Test Circuit for Totem-Pole Outputs

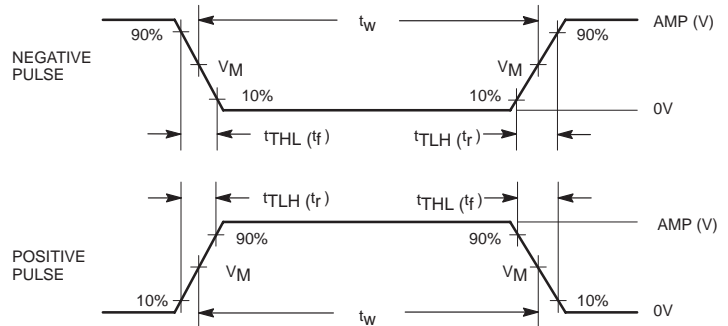

Input Pulse Definition

DEFINITIONS:

- R_L = Load resistor; see AC ELECTRICAL CHARACTERISTICS for value.
- C_L = Load capacitance includes jig and probe capacitance; see AC ELECTRICAL CHARACTERISTICS for value.
- R_T = Termination resistance should be equal to Z_{OUT} of pulse generators.

family	INPUT PULSE REQUIREMENTS					
	amplitude	V_M	rep. rate	t_w	t_{TLH}	t_{THL}
74F	3.0V	1.5V	1MHz	500ns	2.5ns	2.5ns

SF00006

Fiber optic dual LED/clock driver

74F5302

DIP14: plastic dual in-line package; 14 leads (300 mil)

SOT27-1

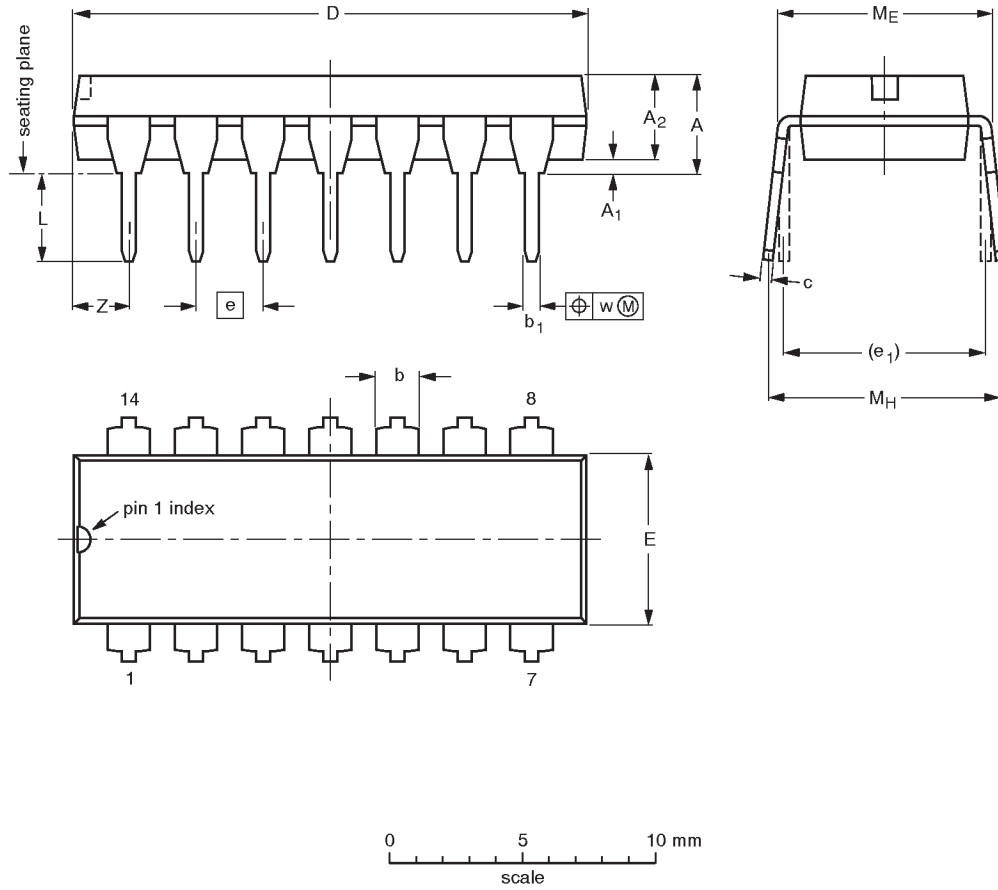

DIMENSIONS (inch dimensions are derived from the original mm dimensions)

UNIT	A max.	A ₁ min.	A ₂ max.	b	b ₁	c	D ⁽¹⁾	E ⁽¹⁾	e	e ₁	L	M _E	M _H	w	Z ⁽¹⁾ max.
mm	4.2	0.51	3.2	1.73 1.13	0.53 0.38	0.36 0.23	19.50 18.55	6.48 6.20	2.54	7.62	3.60 3.05	8.25 7.80	10.0 8.3	0.254	2.2
inches	0.17	0.020	0.13	0.068 0.044	0.021 0.015	0.014 0.009	0.77 0.73	0.26 0.24	0.10	0.30	0.14 0.12	0.32 0.31	0.39 0.33	0.01	0.087

Note

1. Plastic or metal protrusions of 0.25 mm maximum per side are not included.

OUTLINE VERSION	REFERENCES			EUROPEAN PROJECTION	ISSUE DATE
	IEC	JEDEC	EIAJ		
SOT27-1	050G04	MO-001AA			92-11-17 95-03-11

Fiber optic dual LED/clock driver

74F5302

SO14: plastic small outline package; 14 leads; body width 3.9 mm

SOT108-1

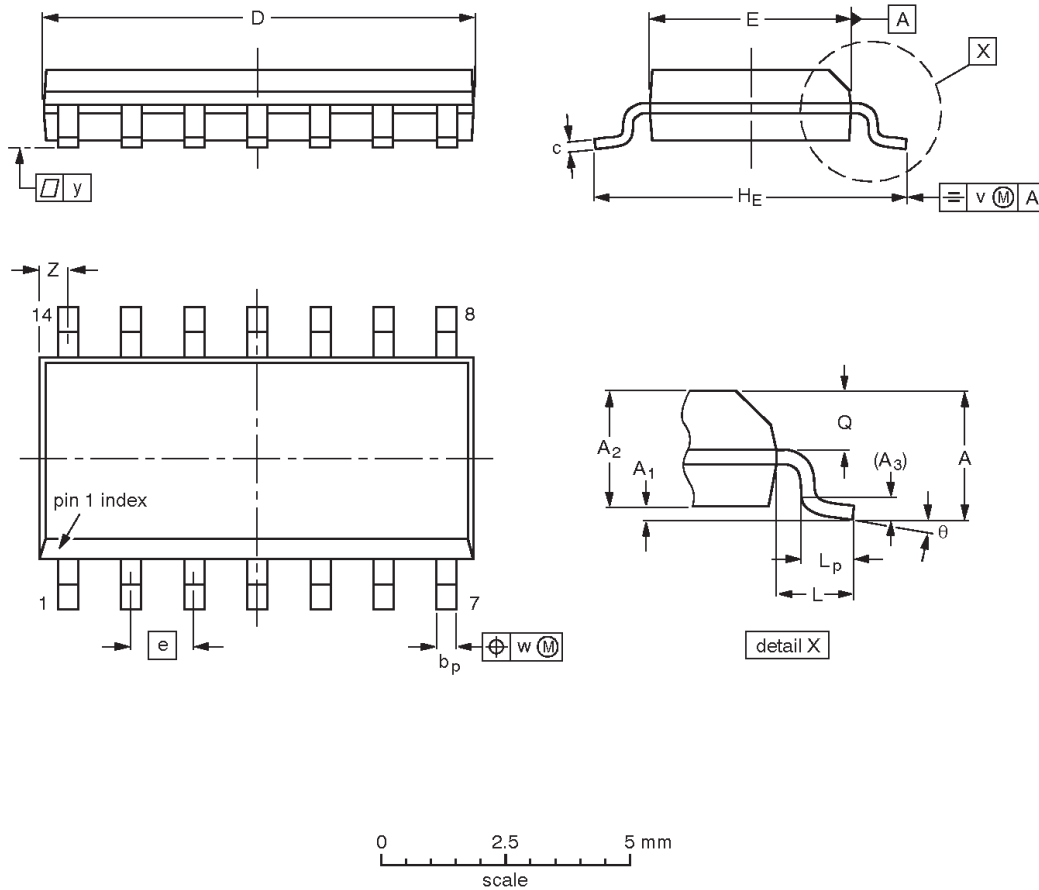

DIMENSIONS (inch dimensions are derived from the original mm dimensions)

UNIT	A max.	A ₁	A ₂	A ₃	b _p	c	D ⁽¹⁾	E ⁽¹⁾	e	H _E	L	L _p	Q	v	w	y	Z ⁽¹⁾	θ
mm	1.75	0.25 0.10	1.45 1.25	0.25	0.49 0.36	0.25 0.19	8.75 8.55	4.0 3.8	1.27	6.2 5.8	1.05	1.0 0.4	0.7 0.6	0.25	0.25	0.1	0.7 0.3	8° 0°
inches	0.069	0.010 0.004	0.057 0.049	0.01	0.019 0.014	0.0100 0.0075	0.35 0.34	0.16 0.15	0.050	0.244 0.228	0.041	0.039 0.016	0.028 0.024	0.01	0.01	0.004	0.028 0.012	

Note

1. Plastic or metal protrusions of 0.15 mm maximum per side are not included.

OUTLINE VERSION	REFERENCES			EUROPEAN PROJECTION	ISSUE DATE
	IEC	JEDEC	EIAJ		
SOT108-1	076E06S	MS-012AB			95-01-29 97-05-22

Fiber optic dual LED/clock driver

74F5302

Data sheet status

Data sheet status	Product status	Definition [1]
Objective specification	Development	This data sheet contains the design target or goal specifications for product development. Specification may change in any manner without notice.
Preliminary specification	Qualification	This data sheet contains preliminary data, and supplementary data will be published at a later date. Philips Semiconductors reserves the right to make changes at any time without notice in order to improve design and supply the best possible product.
Product specification	Production	This data sheet contains final specifications. Philips Semiconductors reserves the right to make changes at any time without notice in order to improve design and supply the best possible product.

[1] Please consult the most recently issued datasheet before initiating or completing a design.

Definitions

Short-form specification — The data in a short-form specification is extracted from a full data sheet with the same type number and title. For detailed information see the relevant data sheet or data handbook.

Limiting values definition — Limiting values given are in accordance with the Absolute Maximum Rating System (IEC 134). Stress above one or more of the limiting values may cause permanent damage to the device. These are stress ratings only and operation of the device at these or at any other conditions above those given in the Characteristics sections of the specification is not implied. Exposure to limiting values for extended periods may affect device reliability.

Application information — Applications that are described herein for any of these products are for illustrative purposes only. Philips Semiconductors make no representation or warranty that such applications will be suitable for the specified use without further testing or modification.

Disclaimers

Life support — These products are not designed for use in life support appliances, devices or systems where malfunction of these products can reasonably be expected to result in personal injury. Philips Semiconductors customers using or selling these products for use in such applications do so at their own risk and agree to fully indemnify Philips Semiconductors for any damages resulting from such application.

Right to make changes — Philips Semiconductors reserves the right to make changes, without notice, in the products, including circuits, standard cells, and/or software, described or contained herein in order to improve design and/or performance. Philips Semiconductors assumes no responsibility or liability for the use of any of these products, conveys no license or title under any patent, copyright, or mask work right to these products, and makes no representations or warranties that these products are free from patent, copyright, or mask work right infringement, unless otherwise specified.

Philips Semiconductors
811 East Arques Avenue
P.O. Box 3409
Sunnyvale, California 94088-3409
Telephone 800-234-7381

© Copyright Philips Electronics North America Corporation 1998
All rights reserved. Printed in U.S.A.

print code

Date of release: 10-98

Document order number:

9397-750-05209

Let's make things better.



LittleDiode supplies new, hard to find or obsolete electronic components and semiconductors all over the world.

With over two million different components listed you are sure to find the part you need.

Feel free to visit us today at our online store:

LittleDiode.com

Looking forward to providing you with the best possible service.