

# DATA SHEET

For a complete data sheet, please also download:

- The IC06 74HC/HCT/HCU/HCMOS Logic Family Specifications
- The IC06 74HC/HCT/HCU/HCMOS Logic Package Information
- The IC06 74HC/HCT/HCU/HCMOS Logic Package Outlines

## **74HC/HCT583**

### **4-bit full adder with fast carry**

Product specification  
Supersedes data of December 1990  
File under Integrated Circuits, IC06

1998 Mar 31

## 4-bit full adder with fast carry

## 74HC/HCT583

## FEATURES

- Adds two decimal numbers
- Full internal look-ahead
- Fast ripple carry for economical expansion
- Output capability: standard driver
- I<sub>CC</sub> category: MSI

## GENERAL DESCRIPTION

The 74HC/HCT583 are high-speed Si-gate CMOS devices and are pin compatible with low power Schottky TTL (LSTTL). They are specified in compliance with JECEC standard no. 7A.

The 74HC/HCT583 are high-speed 4-bit BCD full adders with internal carry look-ahead. They accept two 4-bit decimal numbers (A<sub>0</sub> to A<sub>3</sub> and B<sub>0</sub> to B<sub>3</sub>) and a carry input (C<sub>IN</sub>).

## QUICK REFERENCE DATA

GND = 0 V; T<sub>amb</sub> = 25 °C; t<sub>r</sub> = t<sub>f</sub> = 6 ns

SYMBOL	PARAMETER	CONDITIONS	TYPICAL		UNIT
			HC	HCT	
t <sub>PHL</sub> / t <sub>PLH</sub>	propagation delay	C <sub>L</sub> = 15 pF; V <sub>CC</sub> = 5 V			
	C <sub>IN</sub> to C <sub>n+4</sub>		20	23	ns
	A <sub>n</sub> , B <sub>n</sub> to C <sub>n+4</sub>		23	27	ns
C <sub>I</sub>	input capacitance		3.5	3.5	pF
C <sub>PD</sub>	power dissipation capacitance per package	notes 1 and 2	116	120	pF

## Notes

1. C<sub>PD</sub> is used to determine the dynamic power dissipation (P<sub>D</sub> in μW):

$$P_D = C_{PD} \times V_{CC}^2 \times f_i + \sum (C_L \times V_{CC}^2 \times f_o) \text{ where:}$$

f<sub>i</sub> = input frequency in MHz

f<sub>o</sub> = output frequency in MHz

∑ (C<sub>L</sub> × V<sub>CC</sub><sup>2</sup> × f<sub>o</sub>) = sum of outputs

C<sub>L</sub> = output load capacitance in pF

V<sub>CC</sub> = supply voltage in V

2. For HC the condition is V<sub>I</sub> = GND to V<sub>CC</sub>  
For HCT the condition is V<sub>I</sub> = GND to V<sub>CC</sub> - 1.5 V

The "583" generates the decimal sum outputs (Σ<sub>0</sub> to Σ<sub>3</sub>) and a carry output (C<sub>n+4</sub>) if the sum is greater than 9.

If an addition of two BCD numbers produce a number greater than 9, a valid BCD number and a carry will result. For input values larger than 9, the number is converted from binary to BCD. Binary to BCD conversion occurs by grounding one set of inputs, A<sub>n</sub> or B<sub>n</sub> and applying a 4-bit binary number to the other set of inputs. If the input is between 0 and 9, a BCD number occurs at the output. If the binary input falls between 10 and 15, a carry term is generated. Both the carry term and the sum are the BCD equivalent of the binary input. Converting binary numbers greater than 16 may be achieved by cascading "583s".

See the "283" for the binary version.

# 4-bit full adder with fast carry

# 74HC/HCT583

## ORDERING INFORMATION

TYPE NUMBER	PACKAGE		
	NAME	DESCRIPTION	VERSION
74HC583	DIP16	plastic dual in-line package; 16 leads (300 mil); long body	SOT38-1
74HC583	SO16	plastic small outline package; 16 leads; body width 3.9 mm	SOT109-1
74HCT583	DIP16	plastic dual in-line package; 16 leads (300 mil); long body	SOT38-1
74HCT583	SO16	plastic small outline package; 16 leads; body width 3.9 mm	SOT109-1

## PIN DESCRIPTION

PIN NO.	SYMBOL	NAME AND FUNCTION
5	$C_{IN}$	carry input
6	$C_{n+4}$	carry output
8	GND	ground (0 V)
11, 10, 7, 9	$\Sigma_0$ to $\Sigma_3$	sum outputs
12, 1, 2, 3	$B_0$ to $B_3$	B operand inputs
13, 14, 15, 4	$A_0$ to $A_3$	A operand inputs
16	$V_{CC}$	positive supply voltage

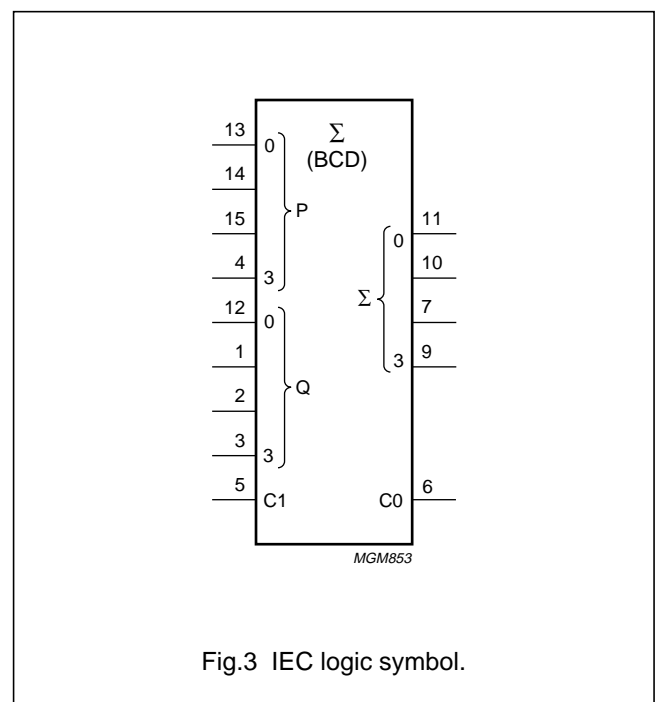
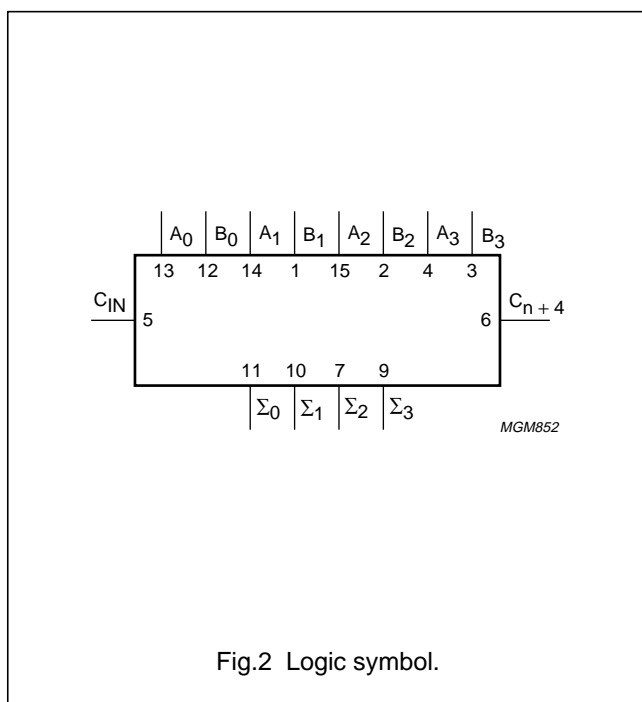
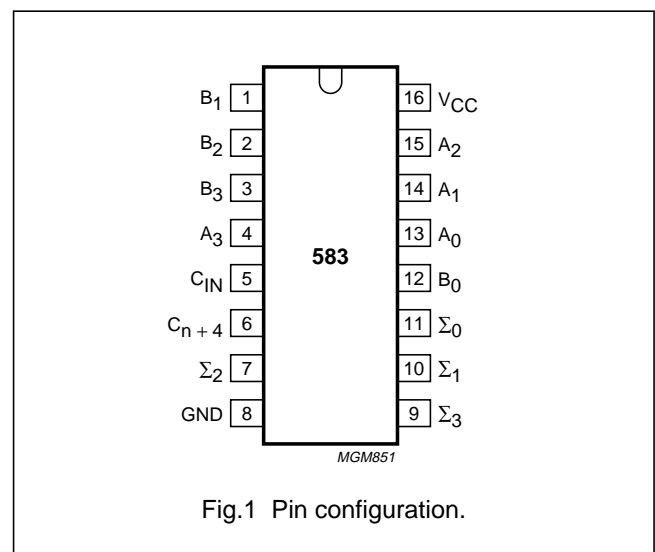

4-bit full adder with fast carry

74HC/HCT583

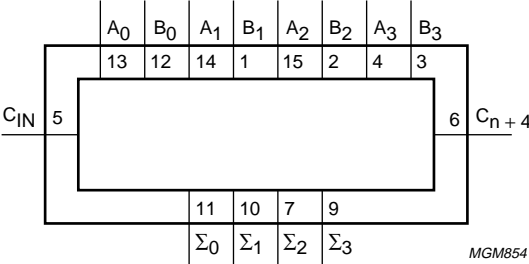

Fig.4 Functional diagram.

# 4-bit full adder with fast carry

# 74HC/HCT583

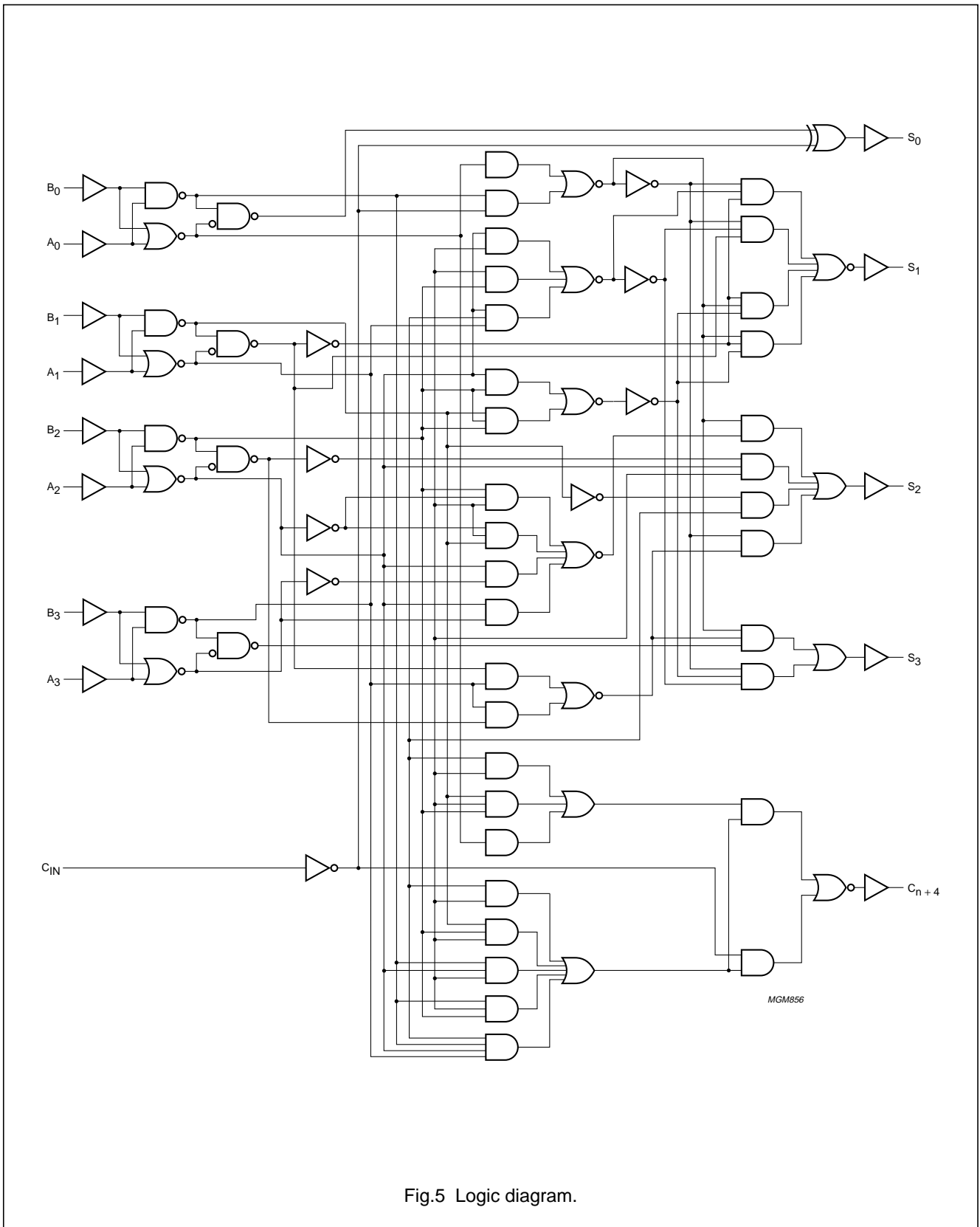

Fig.5 Logic diagram.

## 4-bit full adder with fast carry

## 74HC/HCT583

**DC CHARACTERISTICS FOR 74HC**

For the DC characteristics see "74HC/HCT/HCU/HCMOS Logic Family Specifications".

Output capability: standard I<sub>CC</sub> category: MSI

**AC CHARACTERISTICS FOR 74HC**

GND = 0 V; t<sub>r</sub> = t<sub>f</sub> = 6 ns; C<sub>L</sub> = 50 pF

SYMBOL	PARAMETER	T <sub>amb</sub> (°C)							UNIT	TEST CONDITIONS	
		74HC								V <sub>CC</sub> (V)	WAVEFORMS
		+25			-40 to +85		-40 to +125				
		min.	typ.	max.	min.	max.	min.	max.			
t <sub>PHL</sub> / t <sub>PLH</sub>	propagation delay C <sub>IN</sub> to Σ <sub>0</sub>		50	155		195		235	ns	2.0	Fig.6
			18	31		39		47			
			14	26		33		40			
t <sub>PHL</sub> / t <sub>PLH</sub>	propagation delay C <sub>IN</sub> to Σ <sub>1</sub>		113	350		440		525	ns	2.0	Fig.6
			41	70		88		105			
			33	60		75		90			
t <sub>PHL</sub> / t <sub>PLH</sub>	propagation delay C <sub>IN</sub> to Σ <sub>2</sub>		100	305		380		460	ns	2.0	Fig.6
			36	61		76		92			
			29	52		65		78			
t <sub>PHL</sub> / t <sub>PLH</sub>	propagation delay C <sub>IN</sub> to Σ <sub>3</sub>		110	340		425		510	ns	2.0	Fig.6
			40	68		85		102			
			32	58		72		87			
t <sub>PHL</sub> / t <sub>PLH</sub>	propagation delay A <sub>n</sub> or B <sub>n</sub> to Σ <sub>0</sub>		50	155		195		235	ns	2.0	Fig.6
			18	31		39		47			
			14	26		33		40			
t <sub>PHL</sub> / t <sub>PLH</sub>	propagation delay A <sub>n</sub> or B <sub>n</sub> to Σ <sub>1</sub>		120	365		455		550	ns	2.0	Fig.6
			43	73		91		110			
			34	62		77		94			
t <sub>PHL</sub> / t <sub>PLH</sub>	propagation delay A <sub>n</sub> or B <sub>n</sub> to Σ <sub>2</sub>		105	325		405		490	ns	2.0	Fig.6
			38	65		81		98			
			30	55		69		83			
t <sub>PHL</sub> / t <sub>PLH</sub>	propagation delay A <sub>n</sub> or B <sub>n</sub> to Σ <sub>3</sub>		116	355		445		535	ns	2.0	Fig.6
			42	71		89		107			
			34	60		76		91			
t <sub>PHL</sub> / t <sub>PLH</sub>	propagation delay C <sub>IN</sub> to C <sub>n+4</sub>		63	195		245		295	ns	2.0	Fig.6
			23	39		49		59			
			18	33		42		50			
t <sub>PHL</sub> / t <sub>PLH</sub>	propagation delay A <sub>n</sub> to C <sub>n+4</sub>		72	220		275		330	ns	2.0	Fig.6
			26	44		55		66			
			21	37		47		56			

## 4-bit full adder with fast carry

## 74HC/HCT583

SYMBOL	PARAMETER	T <sub>amb</sub> (°C)							UNIT	TEST CONDITIONS	
		74HC								V <sub>CC</sub> (V)	WAVEFORMS
		+25			-40 to +85		-40 to +125				
		min.	typ.	max.	min.	max.	min.	max.			
t <sub>PHL</sub> / t <sub>PLH</sub>	propagation delay B <sub>n</sub> to C <sub>n+4</sub>		74	230		290		345	ns	2.0	Fig.6
			27	46		58		69		4.5	
			22	39		49		59		6.0	
t <sub>THL</sub> / t <sub>TLH</sub>	output transition time standard outputs		19	75		95		110	ns	2.0	Fig.6
			7	15		19		22		4.5	
			6	13		16		19		6.0	

**DC CHARACTERISTICS FOR 74HCT**

For the DC characteristics see "74HC/HCT/HCU/HCMOS Logic Family Specifications".

Output capability: standard I<sub>CC</sub> category: MSI

**Note to HCT types**

The value of additional quiescent supply current ( $\Delta I_{CC}$ ) for a unit load of 1 is given in the family specifications. To determine  $\Delta I_{CC}$  per input, multiply this value by the unit load coefficient shown in the table below.

INPUT	UNIT LOAD COEFFICIENT
A <sub>n</sub> , B <sub>n</sub>	0.4
C <sub>IN</sub>	1.5

## 4-bit full adder with fast carry

## 74HC/HCT583

## AC CHARACTERISTICS FOR 74HCT

GND = 0 V;  $t_r = t_f = 6$  ns;  $C_L = 50$  pF

SYMBOL	PARAMETER	$T_{amb}$ (°C)							UNIT	TEST CONDITIONS	
		74HCT								$V_{CC}$ (V)	WAVEFORMS
		+25			-40 to +85		-40 to +125				
		min.	typ.	max.	min.	max.	min.	max.			
$t_{PHL}/t_{PLH}$	propagation delay $C_{IN}$ to $\Sigma_0$		20	34		43		51	ns	4.5	Fig.6
$t_{PHL}/t_{PLH}$	propagation delay $C_{IN}$ to $\Sigma_1$		40	68		85		102	ns	4.5	Fig.6
$t_{PHL}/t_{PLH}$	propagation delay $C_{IN}$ to $\Sigma_2$		38	65		81		98	ns	4.5	Fig.6
$t_{PHL}/t_{PLH}$	propagation delay $C_{IN}$ to $\Sigma_3$		38	65		81		98	ns	4.5	Fig.6
$t_{PHL}/t_{PLH}$	propagation delay $A_n$ or $B_n$ to $\Sigma_0$		22	37		46		56	ns	4.5	Fig.6
$t_{PHL}/t_{PLH}$	propagation delay $A_n$ or $B_n$ to $\Sigma_1$		43	73		91		110	ns	4.5	Fig.6
$t_{PHL}/t_{PLH}$	propagation delay $A_n$ or $B_n$ to $\Sigma_2$		40	68		85		102	ns	4.5	Fig.6
$t_{PHL}/t_{PLH}$	propagation delay $A_n$ or $B_n$ to $\Sigma_3$		41	70		88		105	ns	4.5	Fig.6
$t_{PHL}/t_{PLH}$	propagation delay $C_{IN}$ to $C_{n+4}$		27	46		58		69	ns	4.5	Fig.6
$t_{PHL}/t_{PLH}$	propagation delay $A_n$ to $C_{n+4}$		31	53		66		80	ns	4.5	Fig.6
$t_{PHL}/t_{PLH}$	propagation delay $B_n$ to $C_{n+4}$		30	51		64		77	ns	4.5	Fig.6
$t_{THL}/t_{TLH}$	output transition time standard outputs		7	15		19		22	ns	4.5	Fig.6

4-bit full adder with fast carry

74HC/HCT583

AC WAVEFORMS

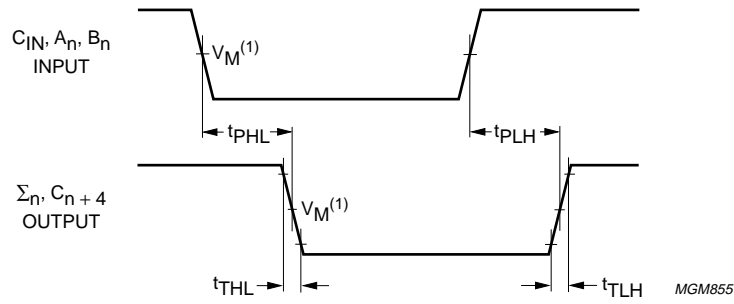

- (1) HC:  $V_M = 50\%$ ;  $V_I = \text{GND to } V_{CC}$ .
- HCT:  $V_M = 1.3 \text{ V}$ ;  $V_I = \text{GND to } 3 \text{ V}$ .

Fig.6 Waveforms showing the inputs ( $C_{IN}$ ,  $A_n$ ,  $B_n$ ) to the outputs ( $\Sigma_n$ ,  $C_{n+4}$ ) propagation delays and the output transition times.

4-bit full adder with fast carry

74HC/HCT583

PACKAGE OUTLINES

DIP16: plastic dual in-line package; 16 leads (300 mil); long body

SOT38-1

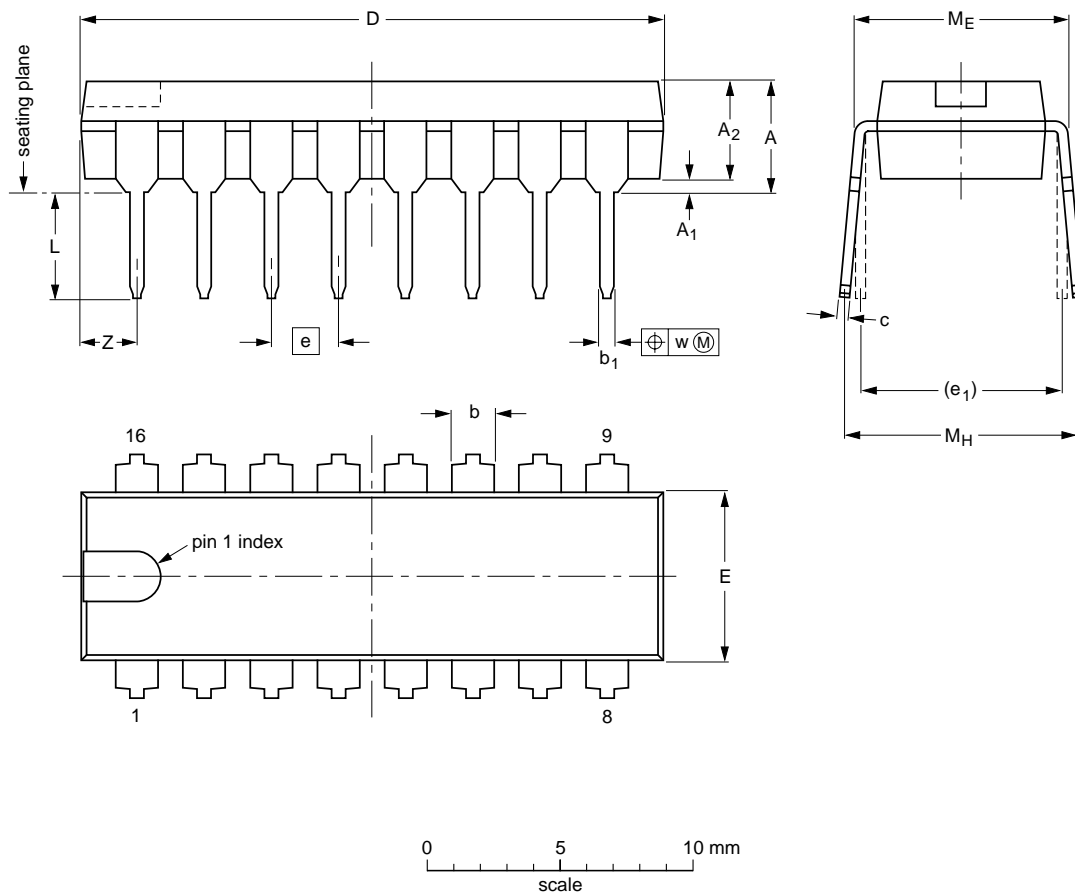

DIMENSIONS (inch dimensions are derived from the original mm dimensions)

UNIT	A max.	A <sub>1</sub> min.	A <sub>2</sub> max.	b	b <sub>1</sub>	c	D <sup>(1)</sup>	E <sup>(1)</sup>	e	e <sub>1</sub>	L	M <sub>E</sub>	M <sub>H</sub>	w	Z <sup>(1)</sup> max.
mm	4.7	0.51	3.7	1.40 1.14	0.53 0.38	0.32 0.23	21.8 21.4	6.48 6.20	2.54	7.62	3.9 3.4	8.25 7.80	9.5 8.3	0.254	2.2
inches	0.19	0.020	0.15	0.055 0.045	0.021 0.015	0.013 0.009	0.86 0.84	0.26 0.24	0.10	0.30	0.15 0.13	0.32 0.31	0.37 0.33	0.01	0.087

Note

1. Plastic or metal protrusions of 0.25 mm maximum per side are not included.

OUTLINE VERSION	REFERENCES				EUROPEAN PROJECTION	ISSUE DATE
	IEC	JEDEC	EIAJ			
SOT38-1	050G09	MO-001AE				92-10-02 95-01-19

4-bit full adder with fast carry

74HC/HCT583

SO16: plastic small outline package; 16 leads; body width 3.9 mm

SOT109-1

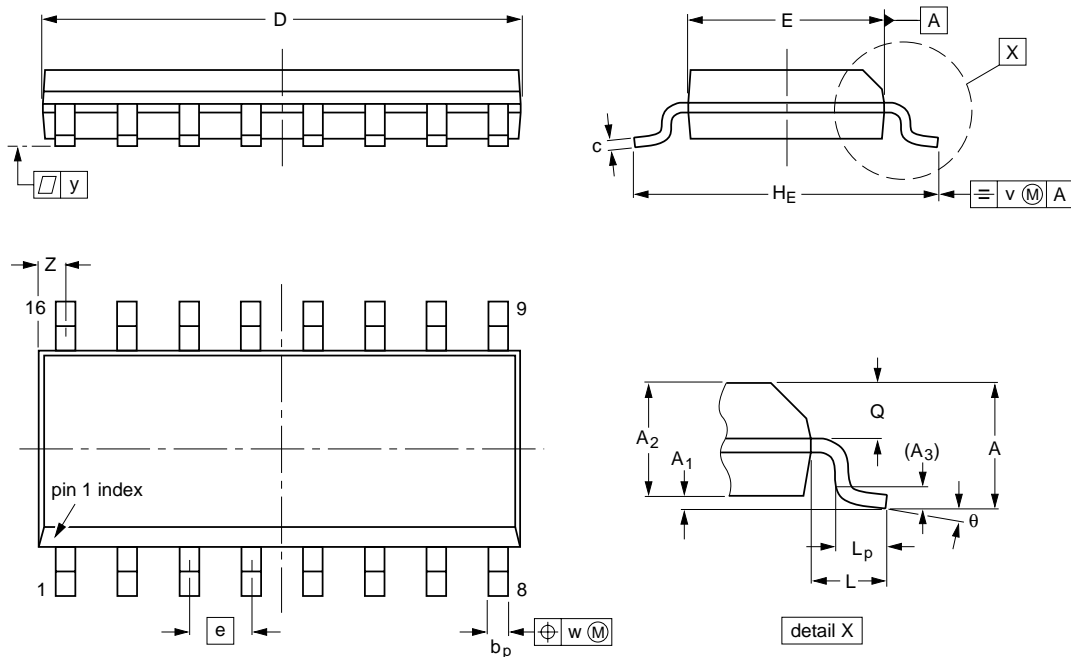

DIMENSIONS (inch dimensions are derived from the original mm dimensions)

UNIT	A max.	A <sub>1</sub>	A <sub>2</sub>	A <sub>3</sub>	b <sub>p</sub>	c	D <sup>(1)</sup>	E <sup>(1)</sup>	e	H <sub>E</sub>	L	L <sub>p</sub>	Q	v	w	y	z <sup>(1)</sup>	θ
mm	1.75	0.25 0.10	1.45 1.25	0.25	0.49 0.36	0.25 0.19	10.0 9.8	4.0 3.8	1.27	6.2 5.8	1.05	1.0 0.4	0.7 0.6	0.25	0.25	0.1	0.7 0.3	8° 0°
inches	0.069	0.010 0.004	0.057 0.049	0.01	0.019 0.014	0.0100 0.0075	0.39 0.38	0.16 0.15	0.050	0.244 0.228	0.041	0.039 0.016	0.028 0.020	0.01	0.01	0.004	0.028 0.012	

Note

1. Plastic or metal protrusions of 0.15 mm maximum per side are not included.

OUTLINE VERSION	REFERENCES			EUROPEAN PROJECTION	ISSUE DATE
	IEC	JEDEC	EIAJ		
SOT109-1	076E07S	MS-012AC			95-01-23 97-05-22

## 4-bit full adder with fast carry

## 74HC/HCT583

**SOLDERING****Introduction**

There is no soldering method that is ideal for all IC packages. Wave soldering is often preferred when through-hole and surface mounted components are mixed on one printed-circuit board. However, wave soldering is not always suitable for surface mounted ICs, or for printed-circuits with high population densities. In these situations reflow soldering is often used.

This text gives a very brief insight to a complex technology. A more in-depth account of soldering ICs can be found in our *"Data Handbook IC26; Integrated Circuit Packages"* (order code 9398 652 90011).

**DIP****SOLDERING BY DIPPING OR BY WAVE**

The maximum permissible temperature of the solder is 260 °C; solder at this temperature must not be in contact with the joint for more than 5 seconds. The total contact time of successive solder waves must not exceed 5 seconds.

The device may be mounted up to the seating plane, but the temperature of the plastic body must not exceed the specified maximum storage temperature ( $T_{stg\ max}$ ). If the printed-circuit board has been pre-heated, forced cooling may be necessary immediately after soldering to keep the temperature within the permissible limit.

**REPAIRING SOLDERED JOINTS**

Apply a low voltage soldering iron (less than 24 V) to the lead(s) of the package, below the seating plane or not more than 2 mm above it. If the temperature of the soldering iron bit is less than 300 °C it may remain in contact for up to 10 seconds. If the bit temperature is between 300 and 400 °C, contact may be up to 5 seconds.

**SO****REFLOW SOLDERING**

Reflow soldering techniques are suitable for all SO packages.

Reflow soldering requires solder paste (a suspension of fine solder particles, flux and binding agent) to be applied to the printed-circuit board by screen printing, stencilling or pressure-syringe dispensing before package placement.

Several techniques exist for reflowing; for example, thermal conduction by heated belt. Dwell times vary between 50 and 300 seconds depending on heating method. Typical reflow temperatures range from 215 to 250 °C.

Preheating is necessary to dry the paste and evaporate the binding agent. Preheating duration: 45 minutes at 45 °C.

**WAVE SOLDERING**

Wave soldering techniques can be used for all SO packages if the following conditions are observed:

- A double-wave (a turbulent wave with high upward pressure followed by a smooth laminar wave) soldering technique should be used.
- The longitudinal axis of the package footprint must be parallel to the solder flow.
- The package footprint must incorporate solder thieves at the downstream end.

During placement and before soldering, the package must be fixed with a droplet of adhesive. The adhesive can be applied by screen printing, pin transfer or syringe dispensing. The package can be soldered after the adhesive is cured.

Maximum permissible solder temperature is 260 °C, and maximum duration of package immersion in solder is 10 seconds, if cooled to less than 150 °C within 6 seconds. Typical dwell time is 4 seconds at 250 °C.

A mildly-activated flux will eliminate the need for removal of corrosive residues in most applications.

**REPAIRING SOLDERED JOINTS**

Fix the component by first soldering two diagonally-opposite end leads. Use only a low voltage soldering iron (less than 24 V) applied to the flat part of the lead. Contact time must be limited to 10 seconds at up to 300 °C. When using a dedicated tool, all other leads can be soldered in one operation within 2 to 5 seconds between 270 and 320 °C.

## 4-bit full adder with fast carry

74HC/HCT583

**DEFINITIONS**

<b>Data sheet status</b>	
Objective specification	This data sheet contains target or goal specifications for product development.
Preliminary specification	This data sheet contains preliminary data; supplementary data may be published later.
Product specification	This data sheet contains final product specifications.
<b>Limiting values</b>	
Limiting values given are in accordance with the Absolute Maximum Rating System (IEC 134). Stress above one or more of the limiting values may cause permanent damage to the device. These are stress ratings only and operation of the device at these or at any other conditions above those given in the Characteristics sections of the specification is not implied. Exposure to limiting values for extended periods may affect device reliability.	
<b>Application information</b>	
Where application information is given, it is advisory and does not form part of the specification.	

**LIFE SUPPORT APPLICATIONS**

These products are not designed for use in life support appliances, devices, or systems where malfunction of these products can reasonably be expected to result in personal injury. Philips customers using or selling these products for use in such applications do so at their own risk and agree to fully indemnify Philips for any damages resulting from such improper use or sale.



LittleDiode supplies new, hard to find or obsolete electronic components and semiconductors all over the world.

With over two million different components listed you are sure to find the part you need.

Feel free to visit us today at our online store:

[LittleDiode.com](http://LittleDiode.com)

Looking forward to providing you with the best possible service.