

# 74HC7403; 74HCT7403

4-bit x 64-word FIFO register; 3-state

Rev. 4 — 24 September 2012

Product data sheet

## 1. General description

---

The 74HC7403; 74HCT7403 is an expandable, First-In First-Out (FIFO) memory organized as 64 words by 4 bits. A guaranteed 15 MHz data-rate makes it ideal for high-speed applications. A higher data-rate can be obtained in applications where the status flags are not used (burst-mode). With separate controls for shift-in (SI) and shift-out ( $\overline{SO}$ ), reading and writing operations are completely independent, allowing synchronous and asynchronous data transfers. Additional controls include a master-reset input ( $\overline{MR}$ ), an output enable input ( $\overline{OE}$ ) and flags. The data-in-ready (DIR) and data-out-ready (DOR) flags indicate the status of the device. Inputs include clamp diodes that enable the use of current limiting resistors to interface inputs to voltages in excess of  $V_{CC}$ .

## 2. Features and benefits

---

- Synchronous or asynchronous operation
- 30 MHz (typical) shift-in and shift-out rates
- Readily expandable in word and bit dimensions
- Pinning arranged for easy board layout: input pins directly opposite output pins
- Input levels:
  - ◆ For 74HC7403: CMOS level
  - ◆ For 74HCT7403: TTL level
- 3-state outputs
- Complies with JEDEC standard JESD7A
- ESD protection:
  - ◆ HBM JESD22-A114F exceeds 2 000 V
  - ◆ MM JESD22-A115-A exceeds 200 V
- Multiple package options
- Specified from  $-40\text{ }^{\circ}\text{C}$  to  $+85\text{ }^{\circ}\text{C}$  and from  $-40\text{ }^{\circ}\text{C}$  to  $+125\text{ }^{\circ}\text{C}$

## 3. Applications

---

- High-speed disc or tape controller
- Communications buffer



## 4. Ordering information

Table 1. Ordering information

Type number	Package			
	Temperature range	Name	Description	Version
74HC7403N	-40 °C to +125 °C	DIP16	plastic dual in-line package; 16 leads (300 mil)	SOT38-4
74HCT7403N				
74HC7403D	-40 °C to +125 °C	SO16	plastic small outline package; 16 leads; body width 3.9 mm	SOT109-1
74HCT7403D				

## 5. Functional diagram

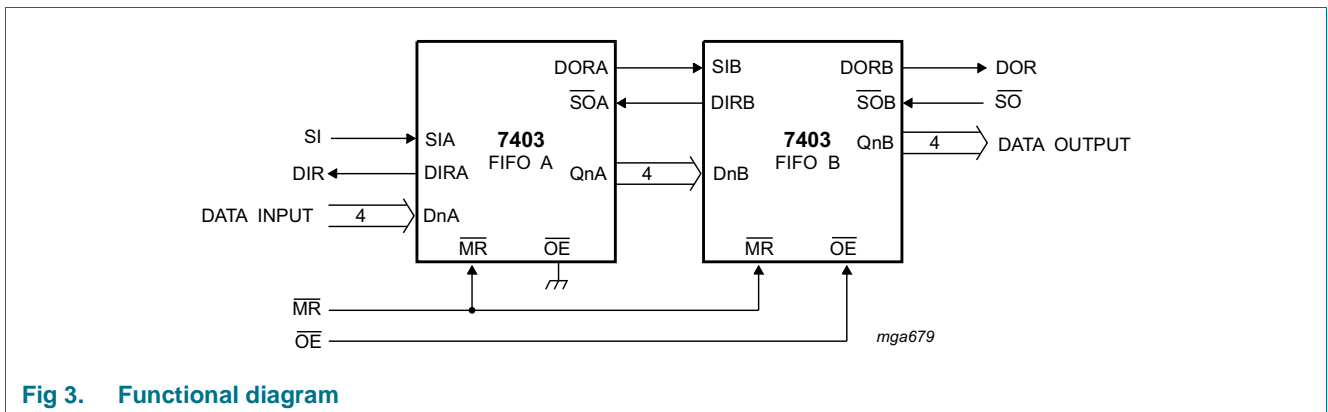
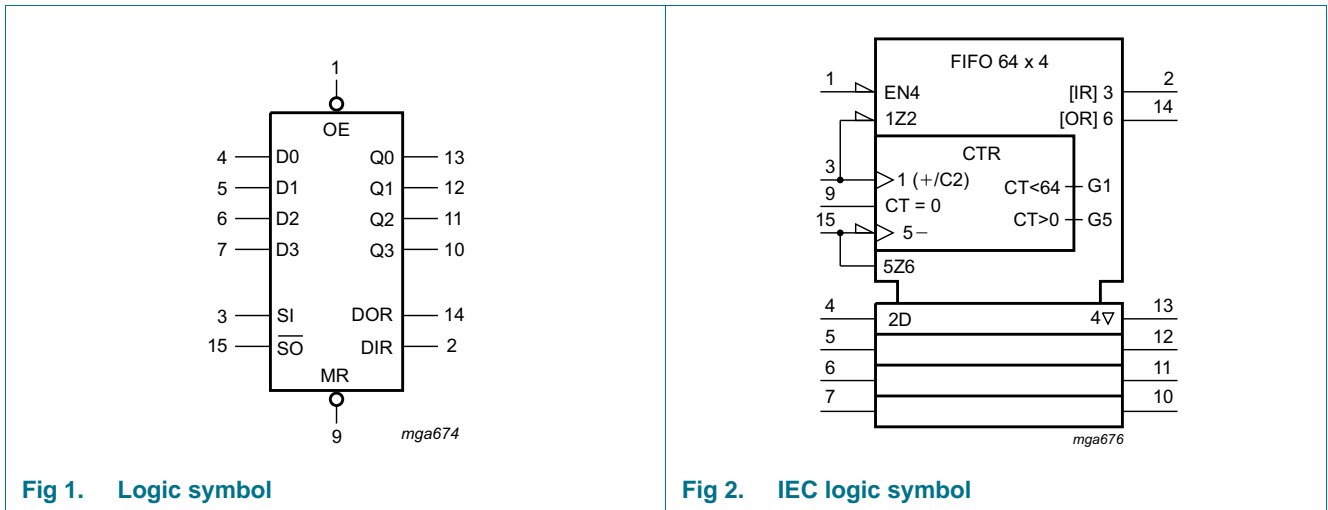

**Fig 3. Functional diagram**

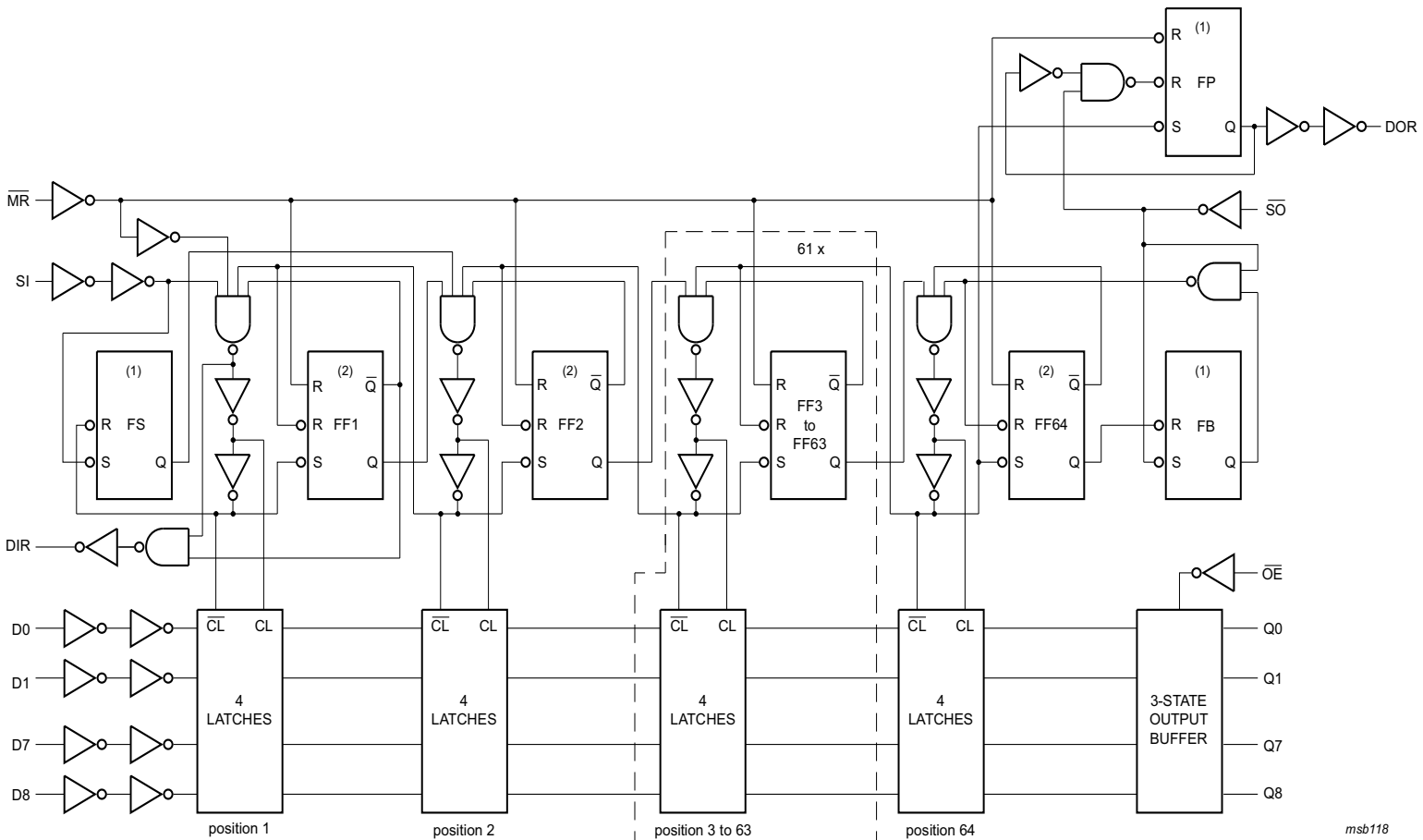

LOW on  $\bar{S}$  input of the flip-flops FS, FB and FP sets Q output to HIGH independent of state on  $\bar{R}$  input  
 LOW on  $\bar{R}$  input of FF1 to FF64 sets Q output to LOW independent of state on  $\bar{S}$  input

Fig 4. Logic diagram

## 6. Pinning information

### 6.1 Pinning

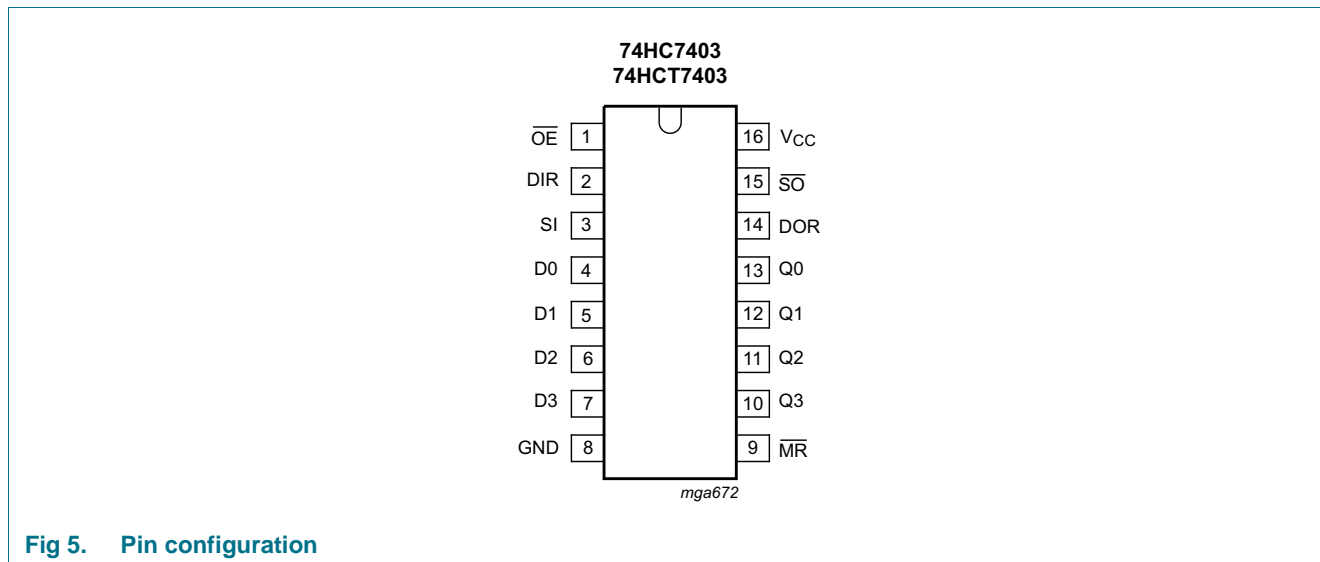

### 6.2 Pin description

**Table 2. Pin description**

Symbol	Pin	Description
$\overline{OE}$	1	output enable input (active LOW)
DIR	2	data-in-ready output
SI	3	shift-in input (active HIGH)
D0 to D3	4, 5, 6, 7	parallel data input
GND	8	ground (0 V)
$\overline{MR}$	9	asynchronous master-reset input (active LOW)
Q0 to Q3	13, 12, 11, 10	data output
DOR	14	data-out-ready output
$\overline{SO}$	15	shift-out input (active LOW)
$V_{CC}$	16	supply voltage

## 7. Functional description

A DIR flag indicates the input stage status, either empty and ready to receive data (DIR = HIGH) or full and busy (DIR = LOW). When DIR and SI are HIGH, data present at D0 to D3 is shifted into the input stage; once complete DIR goes LOW. When SI is set LOW, data is automatically shifted to the output stage or to the last empty location. DIR set HIGH indicates a FIFO which can receive data.

A DOR flag indicates the output stage status, either data available (DOR = HIGH) or busy (DOR = LOW). When  $\overline{SO}$  and DOR are HIGH, data is available at the outputs (Q0 to Q3). When  $\overline{SO}$  is set LOW new data may be shifted into the output stage, once complete DOR is set HIGH.

### 7.1 Expanded format

The DOR and DIR signals are used to allow the 74HC7403; 74HCT7403 to be cascaded. Both parallel and serial expansion is possible. (see [Figure 18](#)).

Serial expansion is only possible with typical devices.

#### 7.1.1 Parallel expansion

Parallel expansion is accomplished by logically ANDing the DOR and DIR signals to form a composite signal.

#### 7.1.2 Serial expansion

Serial expansion is accomplished by:

- Tying the data outputs of the first device to the data inputs of the second device.
- Connecting the DOR pin of the first device to the SI pin of the second device.
- Connecting the  $\overline{SO}$  pin of the first device to the DIR pin of the second device.

## 8. Limiting values

**Table 3. Limiting values**

In accordance with the Absolute Maximum Rating System (IEC 60134). Voltages are referenced to GND (ground = 0 V).

Symbol	Parameter	Conditions	Min	Max	Unit	
$V_{CC}$	supply voltage		-0.5	+7	V	
$I_{IK}$	input clamping current	$V_I < -0.5 \text{ V}$ or $V_I > V_{CC} + 0.5 \text{ V}$	-	$\pm 20$	mA	
$I_{OK}$	output clamping current	$V_O < -0.5 \text{ V}$ or $V_O > V_{CC} + 0.5 \text{ V}$	-	$\pm 20$	mA	
$I_O$	output current	$V_O = -0.5 \text{ V}$ to $(V_{CC} + 0.5 \text{ V})$	-	$\pm 35$	mA	
$I_{CC}$	supply current		-	+70	mA	
$I_{GND}$	ground current		-	-70	mA	
$T_{stg}$	storage temperature		-65	+150	°C	
$P_{tot}$	total power dissipation	DIP16 package	[1]	-	750	mW
		SO16 package	[2]	-	500	mW

[1] For DIP16 packages: above 70 °C the value of  $P_{tot}$  derates linearly with 12 mW/K.

[2] For SO16 packages: above 70 °C the value of  $P_{tot}$  derates linearly with 8 mW/K.

## 9. Recommended operating conditions

**Table 4. Recommended operating conditions**

Voltages are referenced to GND (ground = 0 V)

Symbol	Parameter	Conditions	74HC7403			74HCT7403			Unit
			Min	Typ	Max	Min	Typ	Max	
V <sub>CC</sub>	supply voltage		2.0	5.0	6.0	4.5	5.0	5.5	V
V <sub>I</sub>	input voltage		0	-	V <sub>CC</sub>	0	-	V <sub>CC</sub>	V
V <sub>O</sub>	output voltage		0	-	V <sub>CC</sub>	0	-	V <sub>CC</sub>	V
T <sub>amb</sub>	ambient temperature		-40	+25	+125	-40	+25	+125	°C
Δt/ΔV	input transition rise and fall rate	V <sub>CC</sub> = 2.0 V	-	-	625	-	-	-	ns/V
		V <sub>CC</sub> = 4.5 V	-	1.67	139	-	1.67	139	ns/V
		V <sub>CC</sub> = 6.0 V	-	-	83	-	-	-	ns/V

## 10. Static characteristics

**Table 5. Static characteristics**

At recommended operating conditions; voltages are referenced to GND (ground = 0 V).

Symbol	Parameter	Conditions	25 °C			-40 °C to +85 °C		-40 °C to +125 °C		Unit
			Min	Typ	Max	Min	Max	Min	Max	
<b>74HC7403</b>										
V <sub>IH</sub>	HIGH-level input voltage	V <sub>CC</sub> = 2.0 V	1.5	1.2	-	1.5	-	1.5	-	V
		V <sub>CC</sub> = 4.5 V	3.15	2.4	-	3.15	-	3.15	-	V
		V <sub>CC</sub> = 6.0 V	4.2	3.2	-	4.2	-	4.2	-	V
V <sub>IL</sub>	LOW-level input voltage	V <sub>CC</sub> = 2.0 V	-	0.8	0.5	-	0.5	-	0.5	V
		V <sub>CC</sub> = 4.5 V	-	2.1	1.35	-	1.35	-	1.35	V
		V <sub>CC</sub> = 6.0 V	-	2.8	1.8	-	1.8	-	1.8	V
V <sub>OH</sub>	HIGH-level output voltage	V <sub>I</sub> = V <sub>IH</sub> or V <sub>IL</sub>								
		I <sub>O</sub> = -20 μA; V <sub>CC</sub> = 2.0 V	1.9	2.0	-	1.9	-	1.9	-	V
		I <sub>O</sub> = -20 μA; V <sub>CC</sub> = 4.5 V	4.4	4.5	-	4.4	-	4.4	-	V
		I <sub>O</sub> = -20 μA; V <sub>CC</sub> = 6.0 V	5.9	6.0	-	5.9	-	5.9	-	V
		I <sub>O</sub> = -8 mA; V <sub>CC</sub> = 4.5 V	3.98	4.32	-	3.84	-	3.7	-	V
		I <sub>O</sub> = -10 mA; V <sub>CC</sub> = 6.0 V	5.48	5.81	-	5.34	-	5.2	-	V
V <sub>OL</sub>	LOW-level output voltage	V <sub>I</sub> = V <sub>IH</sub> or V <sub>IL</sub>								
		I <sub>O</sub> = 20 μA; V <sub>CC</sub> = 2.0 V	-	0	0.1	-	0.1	-	0.1	V
		I <sub>O</sub> = 20 μA; V <sub>CC</sub> = 4.5 V	-	0	0.1	-	0.1	-	0.1	V
		I <sub>O</sub> = 20 μA; V <sub>CC</sub> = 6.0 V	-	0	0.1	-	0.1	-	0.1	V
		I <sub>O</sub> = 8 mA; V <sub>CC</sub> = 4.5 V	-	0.15	0.26	-	0.33	-	0.4	V
		I <sub>O</sub> = 10 mA; V <sub>CC</sub> = 6.0 V	-	0.15	0.26	-	0.33	-	0.4	V
I <sub>I</sub>	input leakage current	V <sub>I</sub> = V <sub>CC</sub> or GND; V <sub>CC</sub> = 6.0 V	-	-	±0.1	-	±1.0	-	±1.0	μA
I <sub>OZ</sub>	OFF-state output current	V <sub>I</sub> = V <sub>IH</sub> or V <sub>IL</sub> ; V <sub>O</sub> = V <sub>CC</sub> or GND; V <sub>CC</sub> = 6.0 V	-	-	±0.5	-	±5.0	-	±10.0	μA

**Table 5. Static characteristics ...continued**

At recommended operating conditions; voltages are referenced to GND (ground = 0 V).

Symbol	Parameter	Conditions	25 °C			-40 °C to +85 °C		-40 °C to +125 °C		Unit
			Min	Typ	Max	Min	Max	Min	Max	
$I_{CC}$	supply current	$V_I = V_{CC}$ or GND; $I_O = 0$ A; $V_{CC} = 6.0$ V	-	-	50	-	500	-	1000	$\mu$ A
$C_I$	input capacitance		-	3.5	-					pF
<b>74HCT7403</b>										
$V_{IH}$	HIGH-level input voltage	$V_{CC} = 4.5$ V to 5.5 V	2.0	1.6	-	2.0	-	2.0	-	V
$V_{IL}$	LOW-level input voltage	$V_{CC} = 4.5$ V to 5.5 V	-	1.2	0.8	-	0.8	-	0.8	V
$V_{OH}$	HIGH-level output voltage	$V_I = V_{IH}$ or $V_{IL}$ ; $V_{CC} = 4.5$ V								
		$I_O = -20$ $\mu$ A	4.4	4.5	-	4.4	-	4.4	-	V
		$I_O = -8$ mA	3.98	4.32	-	3.84	-	3.7	-	V
$V_{OL}$	LOW-level output voltage	$V_I = V_{IH}$ or $V_{IL}$ ; $V_{CC} = 4.5$ V								
		$I_O = 20$ $\mu$ A	-	0	0.1	-	0.1	-	0.1	V
		$I_O = 8$ mA	-	0.15	0.26	-	0.33	-	0.4	V
$I_I$	input leakage current	$V_I = V_{CC}$ or GND; $V_{CC} = 5.5$ V	-	-	$\pm 0.1$	-	$\pm 1.0$	-	$\pm 1.0$	$\mu$ A
$I_{OZ}$	OFF-state output current	$V_I = V_{IH}$ or $V_{IL}$ ; $V_{CC} = 5.5$ V; $V_O = V_{CC}$ or GND per input pin; other inputs at $V_{CC}$ or GND; $I_O = 0$ A	-	-	$\pm 0.5$	-	$\pm 5.0$	-	$\pm 10$	$\mu$ A
$I_{CC}$	supply current	$V_I = V_{CC}$ or GND; $I_O = 0$ A; $V_{CC} = 5.5$ V	-	-	50	-	500	-	1000	$\mu$ A
$\Delta I_{CC}$	additional supply current	$V_I = V_{CC} - 2.1$ V; other inputs at $V_{CC}$ or GND; $V_{CC} = 4.5$ V to 5.5 V; $I_O = 0$ A								
		per input pin; Dn inputs	-	75	270	-	338	-	368	$\mu$ A
		per input pin; $\overline{OE}$ input	-	100	360	-	450	-	490	$\mu$ A
		per input pin; SI input	-	150	540	-	675	-	735	$\mu$ A
		per input pin; $\overline{MR}$ input	-	150	540	-	675	-	735	$\mu$ A
		per input pin; $\overline{SO}$ input	-	150	540	-	675	-	735	$\mu$ A
$C_I$	input capacitance		-	3.5	-					pF

## 11. Dynamic characteristics

**Table 6. Dynamic characteristics**

Voltages are referenced to GND (ground = 0 V);  $C_L = 50$  pF unless otherwise specified; for test circuit see [Figure 17](#).

Symbol	Parameter	Conditions	25 °C			-40 °C to +85 °C		-40 °C to +125 °C		Unit
			Min	Typ	Max	Min	Max	Min	Max	
<b>74HC7403</b>										
$t_{pd}$	propagation delay	$\overline{MR}$ to DIR or DOR; see <a href="#">Figure 8</a> <sup>[1]</sup>								
		$V_{CC} = 2.0$ V	-	69	210	-	265	-	315	ns
		$V_{CC} = 4.5$ V	-	25	42	-	53	-	63	ns
		$V_{CC} = 6.0$ V	-	20	36	-	45	-	54	ns
		SI to DIR; see <a href="#">Figure 6</a> <sup>[1]</sup>								
		$V_{CC} = 2.0$ V	-	66	205	-	255	-	310	ns
		$V_{CC} = 4.5$ V	-	24	41	-	51	-	62	ns
		$V_{CC} = 5$ V; $C_L = 15$ pF	-	15	-	-	-	-	-	ns
		$V_{CC} = 6.0$ V	-	19	35	-	43	-	53	ns
		$\overline{SO}$ to DOR; see <a href="#">Figure 9</a> <sup>[1]</sup>								
		$V_{CC} = 2.0$ V	-	94	290	-	365	-	435	ns
		$V_{CC} = 4.5$ V	-	34	58	-	73	-	87	ns
		$V_{CC} = 5$ V; $C_L = 15$ pF	-	15	-	-	-	-	-	ns
		$V_{CC} = 6.0$ V	-	27	49	-	62	-	74	ns
		DOR to Qn; see <a href="#">Figure 10</a> <sup>[1]</sup>								
		$V_{CC} = 2.0$ V	-	11	35	-	45	-	55	ns
$V_{CC} = 4.5$ V	-	4	7	-	9	-	11	ns		
$V_{CC} = 6.0$ V	-	3	6	-	8	-	9	ns		
$\overline{SO}$ to Qn; see <a href="#">Figure 14</a> <sup>[1]</sup>										
$V_{CC} = 2.0$ V	-	105	325	-	406	-	488	ns		
$V_{CC} = 4.5$ V	-	38	65	-	81	-	98	ns		
$V_{CC} = 6.0$ V	-	30	55	-	69	-	83	ns		
$t_{PHL}$	HIGH to LOW propagation delay	$\overline{MR}$ to Qn; see <a href="#">Figure 8</a>								
		$V_{CC} = 2.0$ V	-	52	160	-	200	-	240	ns
		$V_{CC} = 4.5$ V	-	19	32	-	40	-	48	ns
		$V_{CC} = 6.0$ V	-	15	27	-	34	-	41	ns
$t_{PLH}$	LOW to HIGH propagation delay	SI to DOR; see <a href="#">Figure 10</a> <sup>[5]</sup>								
		$V_{CC} = 2.0$ V	-	2.2	7	-	8.8	-	10.5	$\mu$ s
		$V_{CC} = 4.5$ V	-	0.8	1.4	-	1.8	-	2.1	$\mu$ s
		$V_{CC} = 6.0$ V	-	0.6	1.2	-	1.5	-	1.8	$\mu$ s
	$\overline{SO}$ to DIR; see <a href="#">Figure 7</a> <sup>[6]</sup>									
	$V_{CC} = 2.0$ V	-	2.8	9	-	11.2	-	13.5	$\mu$ s	
	$V_{CC} = 4.5$ V	-	1.0	1.8	-	2.2	-	2.7	$\mu$ s	
	$V_{CC} = 6.0$ V	-	0.8	1.5	-	1.9	-	2.3	$\mu$ s	

**Table 6. Dynamic characteristics ...continued**

Voltages are referenced to GND (ground = 0 V);  $C_L = 50$  pF unless otherwise specified; for test circuit see [Figure 17](#).

Symbol	Parameter	Conditions	25 °C			-40 °C to +85 °C		-40 °C to +125 °C		Unit	
			Min	Typ	Max	Min	Max	Min	Max		
$t_{en}$	enable time	$\overline{OE}$ to Qn; see <a href="#">Figure 16</a> <sup>[2]</sup>									
		$V_{CC} = 2.0$ V	-	44	150	-	190	-	225	ns	
		$V_{CC} = 4.5$ V	-	16	30	-	38	-	45	ns	
		$V_{CC} = 6.0$ V	-	13	26	-	32	-	38	ns	
$t_{dis}$	disable time	$\overline{OE}$ to Qn; see <a href="#">Figure 16</a> <sup>[3]</sup>									
		$V_{CC} = 2.0$ V	-	50	150	-	190	-	225	ns	
		$V_{CC} = 4.5$ V	-	18	30	-	38	-	45	ns	
		$V_{CC} = 6.0$ V	-	14	26	-	33	-	38	ns	
$t_t$	transition time	Qn; see <a href="#">Figure 14</a> <sup>[4]</sup>									
		$V_{CC} = 2.0$ V	-	14	60	-	75	-	90	ns	
		$V_{CC} = 4.5$ V	-	5	12	-	15	-	18	ns	
		$V_{CC} = 6.0$ V	-	4	10	-	13	-	15	ns	
$t_w$	pulse width	SI HIGH or LOW; see <a href="#">Figure 6</a>									
		$V_{CC} = 2.0$ V	35	11	-	45	-	55	-	ns	
		$V_{CC} = 4.5$ V	7	4	-	9	-	11	-	ns	
		$V_{CC} = 6.0$ V	6	3	-	8	-	9	-	ns	
		SO HIGH or LOW; see <a href="#">Figure 9</a>									
		$V_{CC} = 2.0$ V	70	22	-	90	-	105	-	ns	
		$V_{CC} = 4.5$ V	14	8	-	18	-	21	-	ns	
		$V_{CC} = 6.0$ V	12	6	-	15	-	18	-	ns	
		DIR HIGH; see <a href="#">Figure 7</a>									
		$V_{CC} = 2.0$ V	10	41	130	8	165	8	195	ns	
		$V_{CC} = 4.5$ V	5	15	26	4	33	4	39	ns	
		$V_{CC} = 6.0$ V	4	12	22	3	28	3	23	ns	
		DOR HIGH; see <a href="#">Figure 10</a>									
		$V_{CC} = 2.0$ V	14	52	160	12	200	12	240	ns	
		$V_{CC} = 4.5$ V	7	19	32	6	40	6	48	ns	
		$V_{CC} = 6.0$ V	6	15	27	5	34	5	41	ns	
$\overline{MR}$ LOW; see <a href="#">Figure 8</a>											
$V_{CC} = 2.0$ V	120	39	-	150	-	180	-	ns			
$V_{CC} = 4.5$ V	24	14	-	30	-	36	-	ns			
$V_{CC} = 6.0$ V	20	11	-	26	-	31	-	ns			
$t_{rec}$	recovery time	$\overline{MR}$ to SI; see <a href="#">Figure 15</a>									
		$V_{CC} = 2.0$ V	80	24	-	100	-	120	-	ns	
		$V_{CC} = 4.5$ V	16	8	-	20	-	24	-	ns	
		$V_{CC} = 6.0$ V	14	7	-	17	-	20	-	ns	

**Table 6. Dynamic characteristics ...continued**

Voltages are referenced to GND (ground = 0 V);  $C_L = 50$  pF unless otherwise specified; for test circuit see [Figure 17](#).

Symbol	Parameter	Conditions	25 °C			-40 °C to +85 °C		-40 °C to +125 °C		Unit
			Min	Typ	Max	Min	Max	Min	Max	
$t_{su}$	set-up time	Dn to SI; see <a href="#">Figure 13</a>								
		$V_{CC} = 2.0$ V	-8	-36	-	-6	-	-6	-	ns
		$V_{CC} = 4.5$ V	-4	-13	-	-3	-	-3	-	ns
		$V_{CC} = 6.0$ V	-3	-10	-	-3	-	-3	-	ns
$t_h$	hold time	Dn to SI; see <a href="#">Figure 13</a>								
		$V_{CC} = 2.0$ V	135	44	-	170	-	205	-	ns
		$V_{CC} = 4.5$ V	27	16	-	34	-	41	-	ns
		$V_{CC} = 6.0$ V	23	13	-	29	-	35	-	ns
$f_{max}$	maximum frequency	SI, $\overline{SO}$ burst mode; see <a href="#">Figure 11</a> and <a href="#">Figure 12</a>								
		$V_{CC} = 2.0$ V	3.6	9.9	-	2.8	-	2.4	-	MHz
		$V_{CC} = 4.5$ V	18	30	-	14	-	12	-	MHz
		$V_{CC} = 5$ V; $C_L = 15$ pF	-	30	-	-	-	-	-	MHz
		$V_{CC} = 6.0$ V	21	36	-	16	-	14	-	MHz
		SI, $\overline{SO}$ using flags; see <a href="#">Figure 6</a> and <a href="#">Figure 9</a>								
		$V_{CC} = 2.0$ V	3.6	9.9	-	2.8	-	2.4	-	MHz
		$V_{CC} = 4.5$ V	18	30	-	14	-	12	-	MHz
		$V_{CC} = 5$ V; $C_L = 15$ pF	-	30	-	-	-	-	-	MHz
		$V_{CC} = 6.0$ V	21	36	-	16	-	14	-	MHz
		SI, $\overline{SO}$ cascaded; see <a href="#">Figure 6</a> and <a href="#">Figure 9</a>								
		$V_{CC} = 2.0$ V	-	7.6	-	-	-	-	-	MHz
		$V_{CC} = 4.5$ V	-	23	-	-	-	-	-	MHz
$V_{CC} = 6.0$ V	-	27	-	-	-	-	-	MHz		
$C_{PD}$	power dissipation capacitance	$V_I = \text{GND to } V_{CC}$	<a href="#">[7]</a>	-	475	-	-	-	-	pF

**Table 6. Dynamic characteristics ...continued**

Voltages are referenced to GND (ground = 0 V);  $C_L = 50$  pF unless otherwise specified; for test circuit see [Figure 17](#).

Symbol	Parameter	Conditions	25 °C			-40 °C to +85 °C		-40 °C to +125 °C		Unit
			Min	Typ	Max	Min	Max	Min	Max	
<b>74HCT7403</b>										
$t_{pd}$	propagation delay	$\overline{MR}$ to DIR or DOR; see <a href="#">Figure 8</a> <sup>[1]</sup>								
		$V_{CC} = 4.5$ V	-	30	51	-	53	-	63	ns
		SI to DIR; see <a href="#">Figure 6</a> <sup>[1]</sup>								
		$V_{CC} = 4.5$ V	-	25	43	-	54	-	65	ns
		$V_{CC} = 5$ V; $C_L = 15$ pF	-	17	-	-	-	-	-	ns
		$\overline{SO}$ to DOR; see <a href="#">Figure 9</a> <sup>[1]</sup>								
		$V_{CC} = 4.5$ V	-	36	61	-	76	-	92	ns
		$V_{CC} = 5$ V; $C_L = 15$ pF	-	17	-	-	-	-	-	ns
		DOR to Qn; see <a href="#">Figure 10</a> <sup>[1]</sup>								
$V_{CC} = 4.5$ V	-	7	12	-	15	-	18	ns		
$t_{PHL}$	HIGH to LOW propagation delay	$\overline{SO}$ to Qn; see <a href="#">Figure 14</a> <sup>[1]</sup>								
		$V_{CC} = 4.5$ V	-	42	72	-	90	-	108	ns
		$\overline{MR}$ to Qn; see <a href="#">Figure 8</a>								
$V_{CC} = 4.5$ V	-	22	38	-	48	-	57	ns		
$t_{PLH}$	LOW to HIGH propagation delay	SI to DOR; see <a href="#">Figure 10</a> <sup>[5]</sup>								
		$V_{CC} = 4.5$ V	-	0.8	1.4	-	1.75	-	2.1	$\mu$ s
		$\overline{SO}$ to DIR; see <a href="#">Figure 7</a> <sup>[6]</sup>								
$V_{CC} = 4.5$ V	-	1.0	1.8	-	2.25	-	2.7	$\mu$ s		
$t_{en}$	enable time	$\overline{OE}$ to Qn; see <a href="#">Figure 16</a> <sup>[2]</sup>								
		$V_{CC} = 4.5$ V	-	16	30	-	38	-	45	ns
$t_{dis}$	disable time	$\overline{OE}$ to Qn; see <a href="#">Figure 16</a> <sup>[3]</sup>								
		$V_{CC} = 4.5$ V	-	19	30	-	38	-	45	ns
$t_t$	transition time	Qn; see <a href="#">Figure 14</a> <sup>[4]</sup>								
		$V_{CC} = 4.5$ V	-	5	12	-	15	-	18	ns
$t_W$	pulse width	SI HIGH or LOW; see <a href="#">Figure 6</a>								
		$V_{CC} = 4.5$ V	9	5	-	6	-	8	-	ns
		$\overline{SO}$ HIGH or LOW; see <a href="#">Figure 9</a>								
		$V_{CC} = 4.5$ V	14	8	-	18	-	21	-	ns
		DIR HIGH; see <a href="#">Figure 7</a>								
		$V_{CC} = 4.5$ V	5	17	29	4	36	4	44	ns
		DOR HIGH; see <a href="#">Figure 10</a>								
		$V_{CC} = 4.5$ V	7	21	36	6	45	6	54	ns
$t_W$	pulse width	$\overline{MR}$ LOW; see <a href="#">Figure 8</a>								
		$V_{CC} = 4.5$ V	26	15	-	33	-	39	-	ns

**Table 6. Dynamic characteristics ...continued**

Voltages are referenced to GND (ground = 0 V);  $C_L = 50$  pF unless otherwise specified; for test circuit see [Figure 17](#).

Symbol	Parameter	Conditions	25 °C			-40 °C to +85 °C		-40 °C to +125 °C		Unit
			Min	Typ	Max	Min	Max	Min	Max	
$t_{rec}$	recovery time	$\overline{MR}$ to SI; see <a href="#">Figure 15</a>								
		$V_{CC} = 4.5$ V	18	10	-	23	-	27	-	ns
$t_{su}$	set-up time	Dn to SI; see <a href="#">Figure 13</a>								
		$V_{CC} = 4.5$ V	-5	-16	-	-4	-	-4	-	ns
$t_h$	hold time	Dn to SI; see <a href="#">Figure 13</a>								
		$V_{CC} = 4.5$ V	30	18	-	38	-	45	-	ns
$f_{max}$	maximum frequency	SI, $\overline{SO}$ burst mode; see <a href="#">Figure 11</a> and <a href="#">Figure 12</a>								
		$V_{CC} = 4.5$ V	18	30	-	14	-	12	-	MHz
		$V_{CC} = 5$ V; $C_L = 15$ pF	-	30	-	-	-	-	-	MHz
		SI, $\overline{SO}$ using flags; see <a href="#">Figure 6</a> and <a href="#">Figure 9</a>								
		$V_{CC} = 4.5$ V	18	30	-	14	-	12	-	MHz
		$V_{CC} = 5$ V; $C_L = 15$ pF	-	30	-	-	-	-	-	MHz
$C_{PD}$	power dissipation capacitance	SI, $\overline{SO}$ cascaded; see <a href="#">Figure 6</a> and <a href="#">Figure 9</a>								
		$V_{CC} = 4.5$ V	-	23	-	-	-	-	-	MHz
		$V_I = GND$ to $V_{CC} - 1.5$ V	[7]	-	490	-	-	-	-	pF

- [1]  $t_{pd}$  is the same as  $t_{PLH}$  and  $t_{PHL}$ .
- [2]  $t_{en}$  is the same as  $t_{PZH}$  and  $t_{PZL}$ .
- [3]  $t_{dis}$  is the same as  $t_{PLZ}$  and  $t_{PHZ}$ .
- [4]  $t_t$  is the same as  $t_{THL}$  and  $t_{TLH}$ .
- [5] This is the ripple through delay.
- [6] This is the bubble-up delay.
- [7]  $C_{PD}$  is used to determine the dynamic power dissipation ( $P_D$  in  $\mu W$ ).  
 $P_D = C_{PD} \times V_{CC}^2 \times f_i \times N + \sum(C_L \times V_{CC}^2 \times f_o)$  where:  
 $f_i$  = input frequency in MHz;  
 $f_o$  = output frequency in MHz;  
 $C_L$  = output load capacitance in pF;  
 $V_{CC}$  = supply voltage in V;  
 $N$  = number of inputs switching;  
 $\sum(C_L \times V_{CC}^2 \times f_o)$  = sum of outputs.

12. Waveforms

12.1 Shifting in sequence FIFO empty to FIFO full

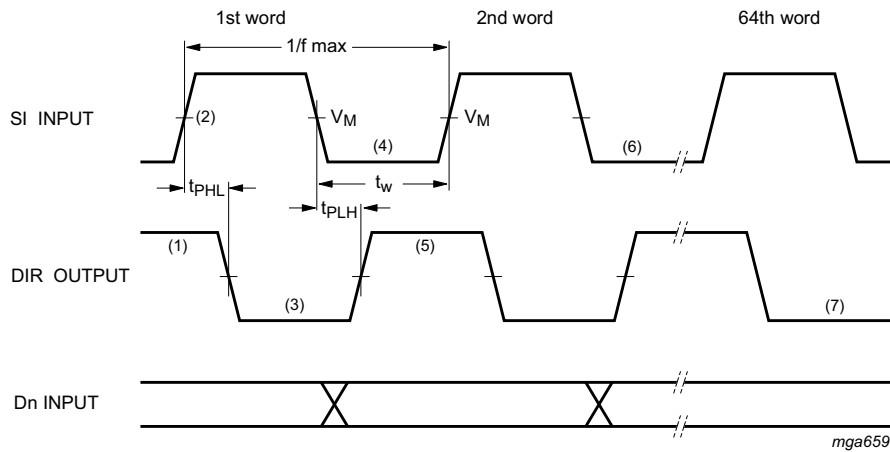

Measurement points are given in [Table 7](#).

$V_{OL}$  and  $V_{OH}$  are typical voltage output levels that occur with the output load.

- (1) DIR initially HIGH; FIFO is prepared for valid data
- (2) SI set HIGH; data loaded into input stage
- (3) DIR goes LOW; input stage "busy"
- (4) SI set LOW; data from first location "ripple through"
- (5) DIR goes HIGH; status flag indicates FIFO prepared for additional data
- (6) Repeat process to load 2<sup>nd</sup> word through to 64<sup>th</sup> word into FIFO; DIR remains LOW; with attempt to shift into full FIFO, no data transfer occurs.

Fig 6. Propagation delay SI input to DIR output, the SI pulse width and the SI maximum frequency

12.2 With FIFO full; SI held HIGH in anticipation of empty location

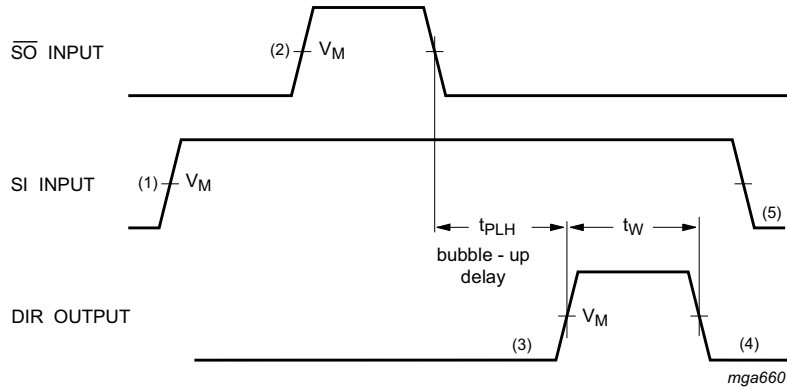

Measurement points are given in [Table 7](#).

$V_{OL}$  and  $V_{OH}$  are typical voltage output levels that occur with the output load.

- (1) FIFO is initially full, shift-in is held HIGH
- (2)  $\overline{SO}$  pulse; data in output stage is unloaded, "bubble-up" process of empty location begins
- (3) DIR HIGH; when empty location reaches input stage, flag indicates that FIFO is prepared for data input
- (4) DIR returns to LOW; data shift-in to empty location is complete, FIFO is full again
- (5) SI set LOW; necessary to complete shift-in process, DIR remains LOW, because FIFO is full

**Fig 7. Bubble-up delay  $\overline{SO}$  input to DIR output, the DIR pulse width.**

12.3 Master reset applied with FIFO full

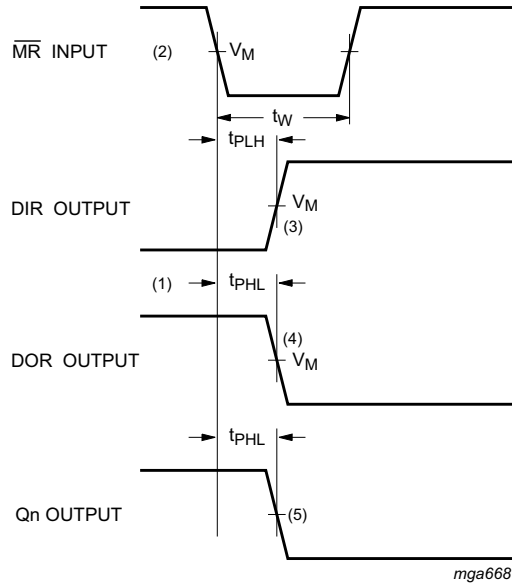

Measurement points are given in [Table 7](#).

$V_{OL}$  and  $V_{OH}$  are typical voltage output levels that occur with the output load.

- (1) DIR LOW; output ready HIGH; assume that FIFO is full
- (2)  $\overline{MR}$  pulse LOW; clears FIFO
- (3) DIR goes HIGH; flag indicates input prepared for valid data
- (4) DOR goes LOW; flag indicates FIFO empty
- (5) Qn outputs go LOW (only last bit is reset)

**Fig 8. Propagation delay  $\overline{MR}$  input to DIR output, DOR output and Qn outputs and the  $\overline{MR}$  pulse width.**

12.4  $\overline{S\bar{O}}$  input to DOR output propagation delay

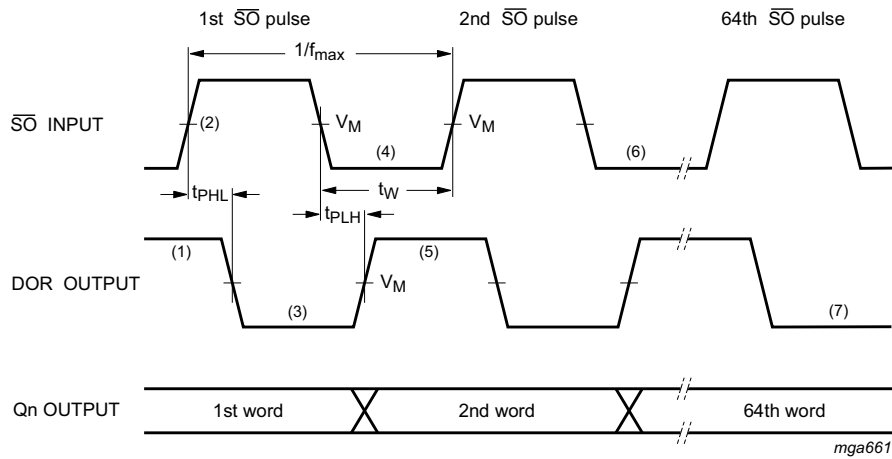

Measurement points are given in [Table 7](#).

$V_{OL}$  and  $V_{OH}$  are typical voltage output levels that occur with the output load.

- (1)  $\overline{S\bar{O}}$  HIGH; no data transfer in progress, valid data is present at the output stage
- (2)  $\overline{S\bar{O}}$  set HIGH; result in DOR going LOW
- (3) DOR goes LOW; output stage “busy”
- (4)  $\overline{S\bar{O}}$  set LOW; data in the input stage is unloaded, and new data replaces it as empty location “bubbles-up” to input stage
- (5) DOR goes HIGH; transfer process completed, valid data present at output after the specified propagation delay
- (6) Repeat process to unload the 3<sup>rd</sup> through the 64<sup>th</sup> word from FIFO
- (7) DOR remains LOW; FIFO is empty

**Fig 9. Propagation delay  $\overline{S\bar{O}}$  input to DOR output, the  $\overline{S\bar{O}}$  pulse width and the  $\overline{S\bar{O}}$  maximum frequency.**

12.5 With FIFO empty;  $\overline{SO}$  is held HIGH in anticipation

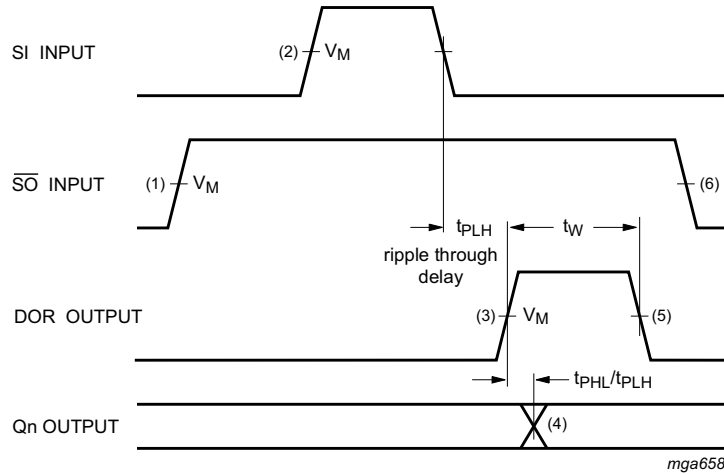

Measurement points are given in [Table 7](#).

$V_{OL}$  and  $V_{OH}$  are typical voltage output levels that occur with the output load.

- (1) FIFO is initially empty.  $\overline{SO}$  is held HIGH.
- (2) SI pulse; loads data into FIFO and initiates ripple through process
- (3) DOR flag signals the arrival of valid data at the output stage
- (4) Output transition; data arrives at output stage after the specified propagation delay between the rising and falling edge of the DOR pulse to the Qn output
- (5) DOR goes LOW; data shift-out is completed, FIFO is empty again
- (6)  $\overline{SO}$  set LOW; necessary to complete shift-out process. DOR remains LOW, because FIFO is empty

Fig 10. Ripple through delay SI input to DOR output, propagation delay DOR input to Qn outputs and the DOR pulse width

12.6 Shift-in operation; high speed burst mode

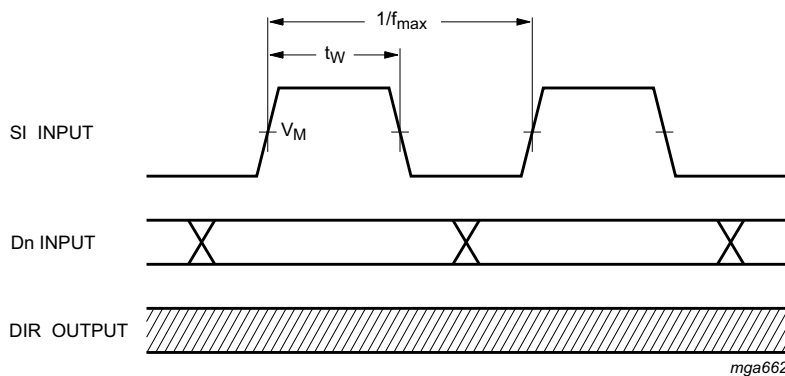

Measurement points are given in [Table 7](#).

$V_{OL}$  and  $V_{OH}$  are typical voltage output levels that occur with the output load.

In the high-speed mode, the burst-in rate is determined by the minimum shift-in HIGH and shift-in LOW specifications. The DIR status flag is a “don’t care” condition, and a shift-in pulse can be applied regardless of the flag. An SI pulse which would overflow the storage capacity of the FIFO is ignored.

Fig 11. The SI pulse width and the SI maximum frequency

12.7 Shift-out operation; high speed burst mode

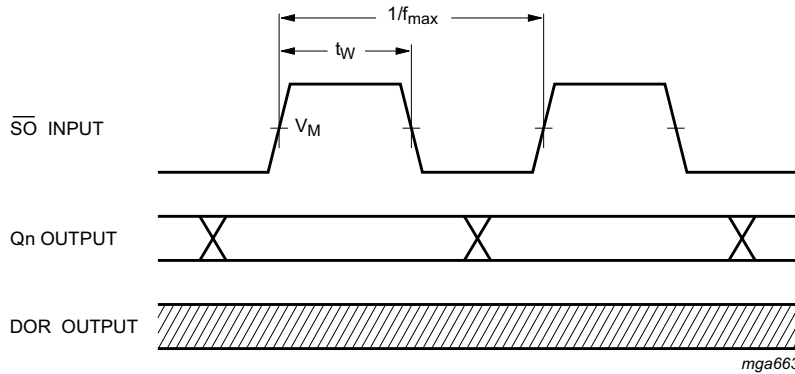

Measurement points are given in [Table 7](#).

$V_{OL}$  and  $V_{OH}$  are typical voltage output levels that occur with the output load.

In the high-speed mode, the burst rate is determined by the minimum shift-out HIGH and shift-out LOW specifications. The DOR flag is a "don't care" condition, and an  $\overline{SO}$  pulse can be applied without regard to the flag.

Fig 12. The  $\overline{SO}$  pulse width and the  $\overline{SO}$  maximum frequency

12.8 Set-up and hold times

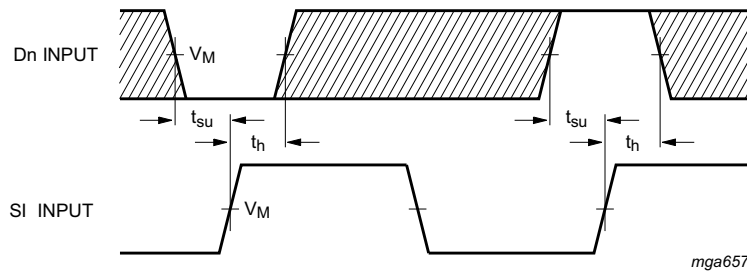

Measurement points are given in [Table 7](#).

$V_{OL}$  and  $V_{OH}$  are typical voltage output levels that occur with the output load.

The shaded areas indicate when the output is permitted to change for predictable output performance

Fig 13. Set-up and hold times

12.9  $\overline{SO}$  input to Qn outputs propagation delay

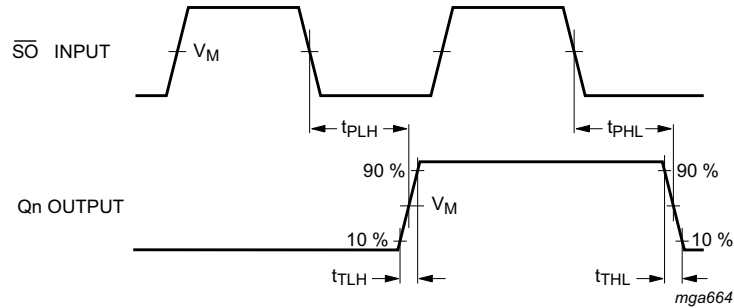

Measurement points are given in [Table 7](#).

$V_{OL}$  and  $V_{OH}$  are typical voltage output levels that occur with the output load.

Fig 14. Propagation delay  $\overline{SO}$  input to Qn outputs and the output transition time

12.10  $\overline{MR}$  to SI recovery time

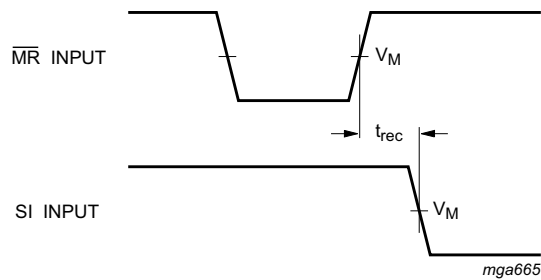

Measurement points are given in [Table 7](#).

$V_{OL}$  and  $V_{OH}$  are typical voltage output levels that occur with the output load.

Fig 15.  $\overline{MR}$  to SI recovery time

12.11 Enable and disable times

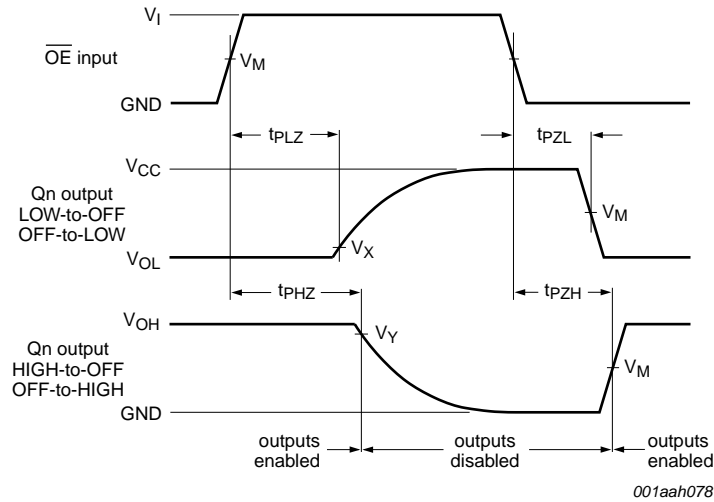

Measurement points are given in [Table 7](#).

$V_{OL}$  and  $V_{OH}$  are typical voltage output levels that occur with the output load.

Fig 16. Enable and disable times

12.12 Test circuit for measuring switching times

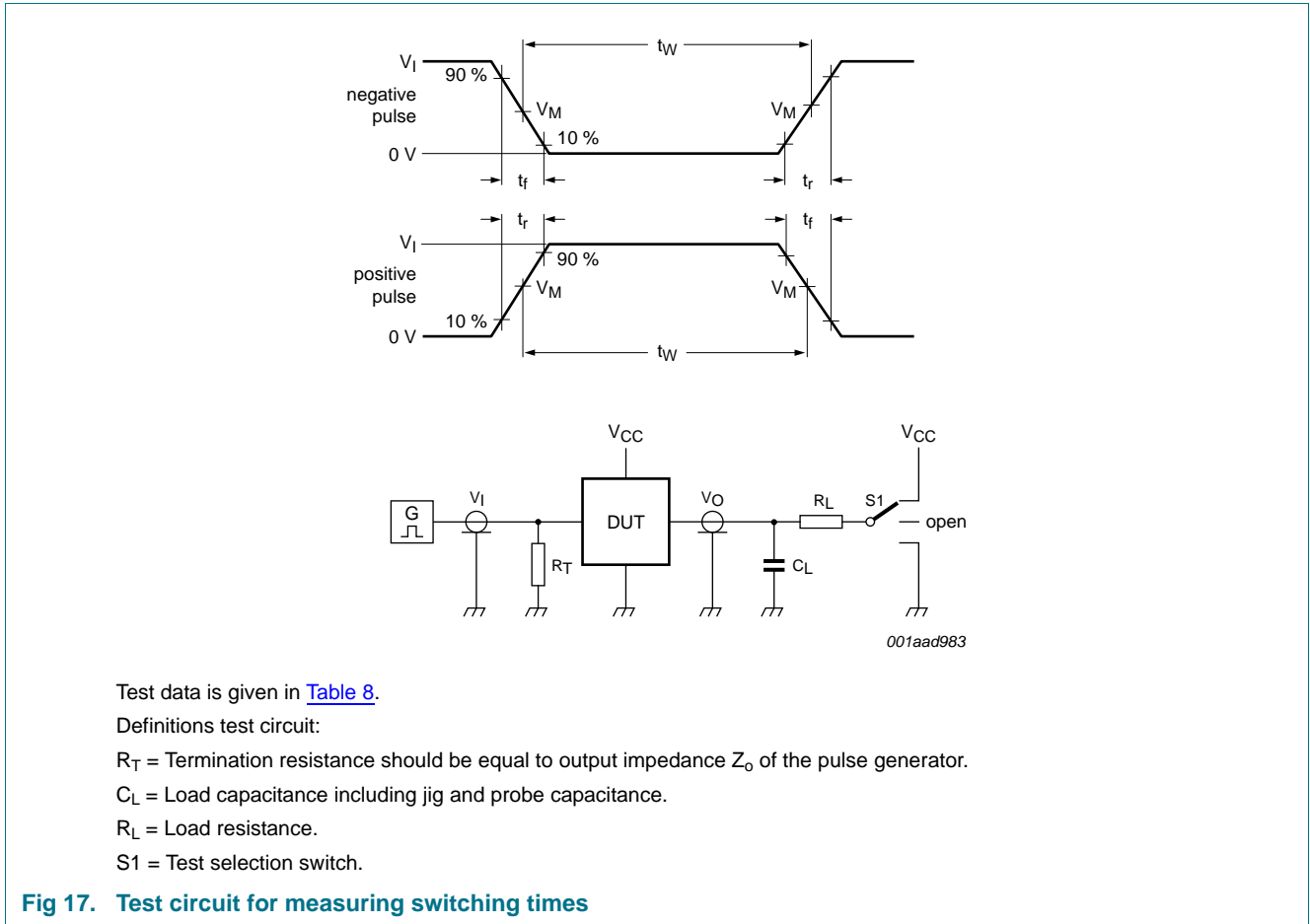

Fig 17. Test circuit for measuring switching times

Table 7. Measurement points

Type	Input		Output		
	$V_M$		$V_M$	$V_X$	$V_Y$
74HC7403	$0.5V_{CC}$		$0.5V_{CC}$	$0.1V_{CC}$	$0.9V_{CC}$
74HCT7403	1.3 V		1.3 V	$0.1V_{CC}$	$0.9V_{CC}$

Table 8. Test data

Type	Input		Load		S1 position		
	$V_I$	$t_r, t_f$	$C_L$	$R_L$	$t_{PHL}, t_{PLH}$	$t_{PZH}, t_{PHZ}$	$t_{PZL}, t_{PLZ}$
74HC7403	$V_{CC}$	6 ns	15 pF, 50 pF	1 k $\Omega$	open	GND	$V_{CC}$
74HCT7403	3 V	6 ns	15 pF, 50 pF	1 k $\Omega$	open	GND	$V_{CC}$

13. Application information

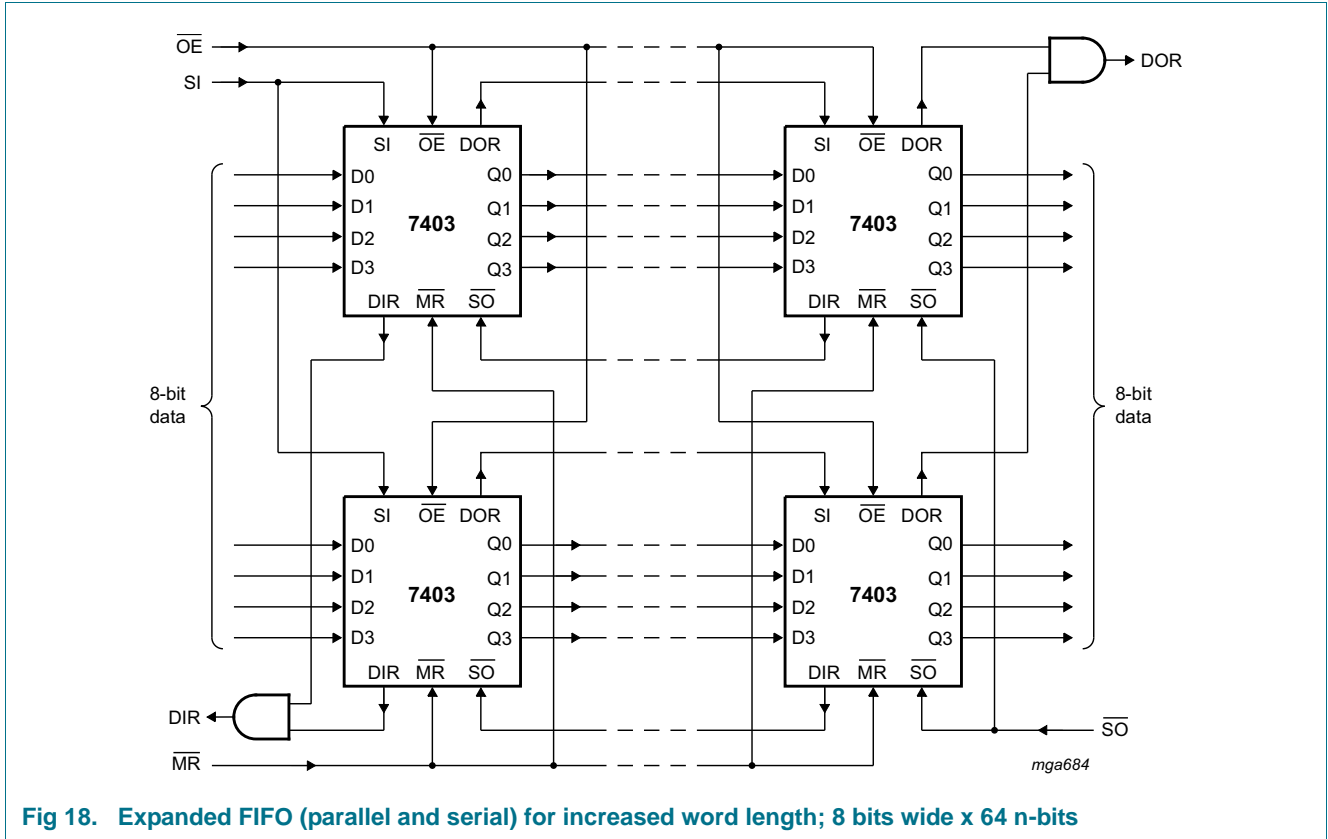
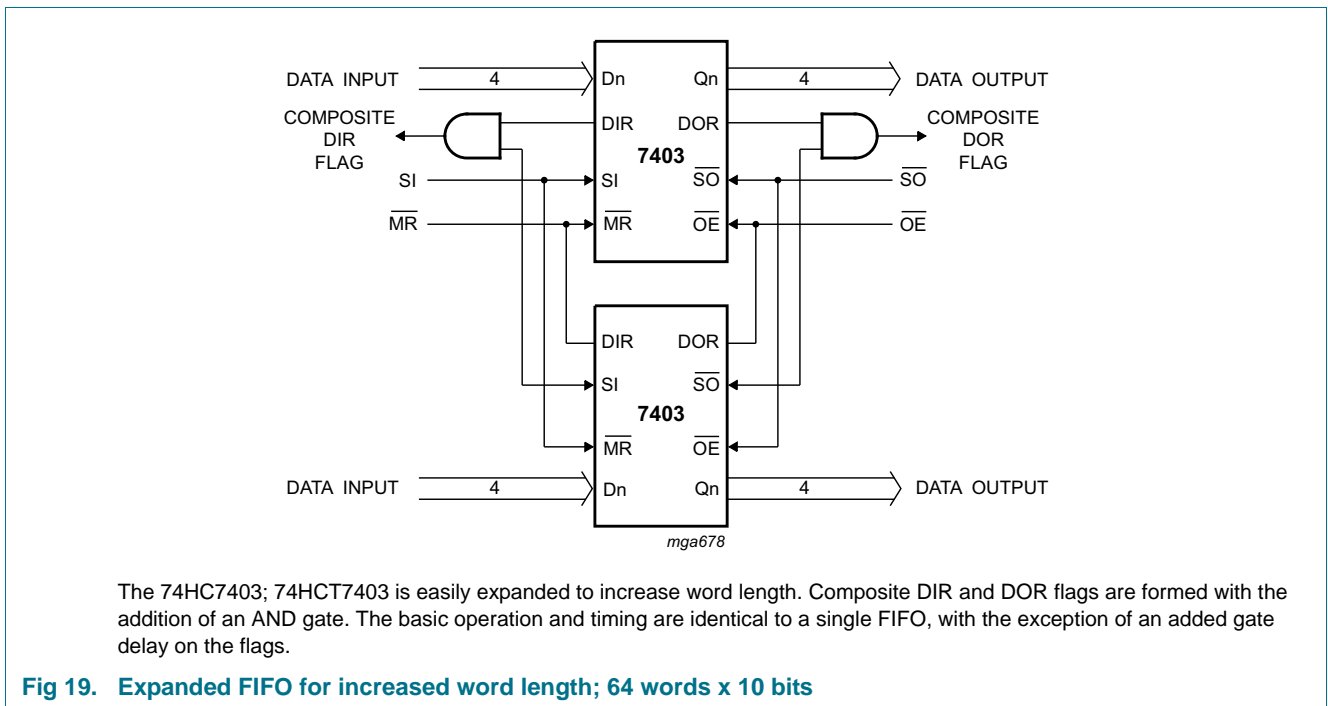

Fig 18. Expanded FIFO (parallel and serial) for increased word length; 8 bits wide x 64 n-bits



The 74HC7403; 74HCT7403 is easily expanded to increase word length. Composite DIR and DOR flags are formed with the addition of an AND gate. The basic operation and timing are identical to a single FIFO, with the exception of an added gate delay on the flags.

Fig 19. Expanded FIFO for increased word length; 64 words x 10 bits





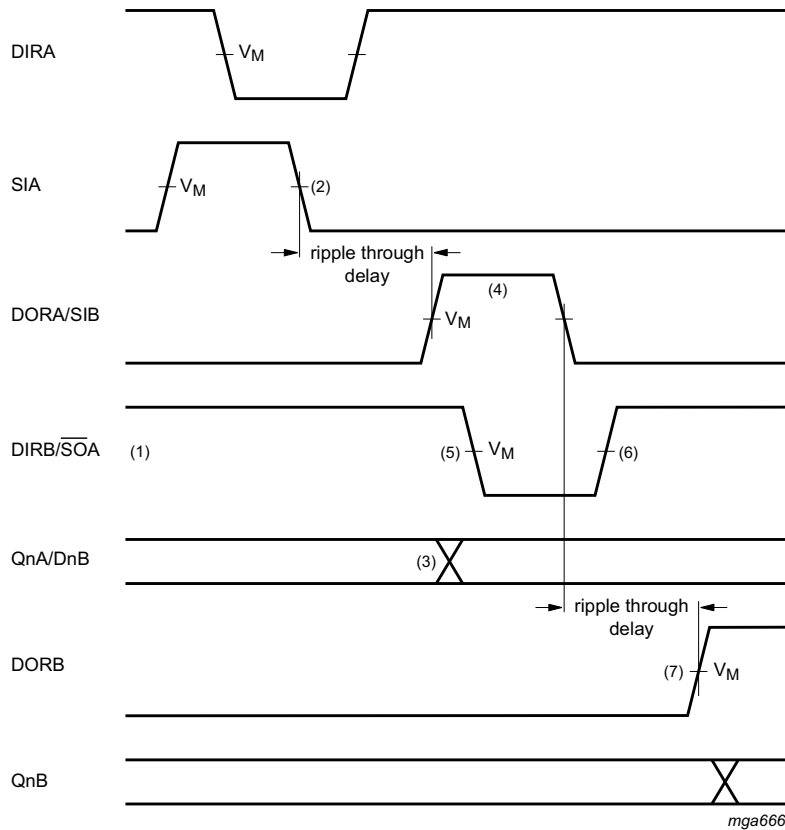

- (1) FIFOA and FIFOB are initially empty,  $\overline{SOA}$  held HIGH in anticipation of data
- (2) Load one word into FIFOA; SI pulse; applied. results in DIR pulse
- (3) Data-out A/ data-in B transition; valid data arrives at FIFOA output stage after a specified delay of the DOR flag, meeting data input set-up requirements of FIFOB.
- (4) DORA and SIB pulse HIGH; (ripple through delay after SIA LOW) data is unloaded from FIFOA as a result of the data output ready pulse, data is shifted into FIFOB
- (5) DIRB and  $\overline{SOA}$  go LOW; flag indicates that input stage of FIFOB is busy, shift-out of FIFOA is complete
- (6) DIRB and  $\overline{SOA}$  go HIGH automatically; the input stage of FIFOB is again able to receive data,  $\overline{SO}$  is held HIGH in anticipation of additional data
- (7) DORB goes HIGH; (ripple through delay after SIB LOW) valid data is present one propagation delay later at the FIFOB output stage

Fig 22. FIFO to FIFO communication; input timing under empty condition

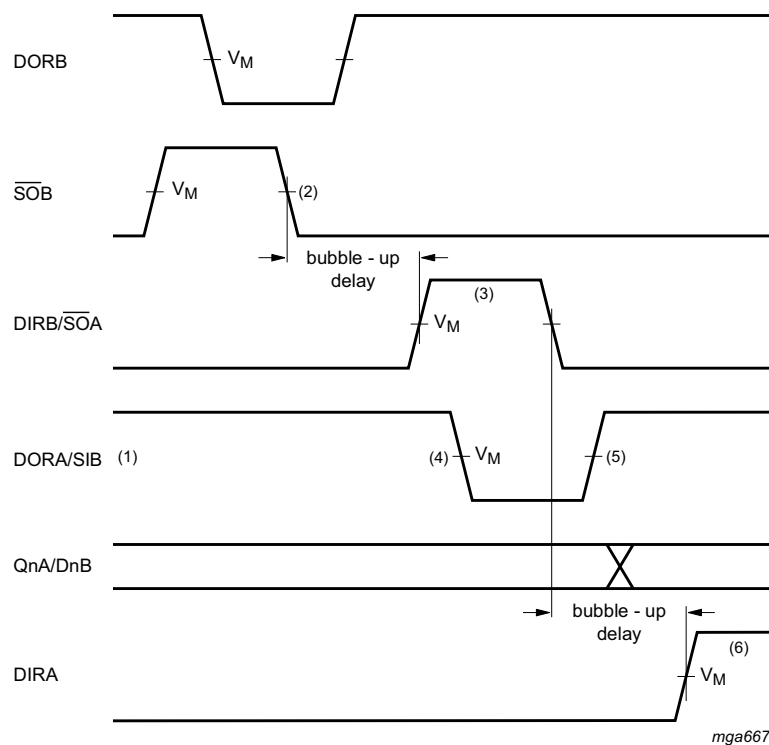

- (1) FIFOA and FIFOB initially full, SIB held HIGH in anticipation of shifting in new data as an empty location bubbles-up
- (2) Unload one word from FIFOB;  $\overline{SÖ}$  pulse applied, results in DOR pulse
- (3) DIRB and  $\overline{SÖA}$  pulse HIGH; (bubble-up delay after  $\overline{SÖB}$  LOW) data is loaded into FIFOB as a result of the DIR pulse, data is shifted out of FIFOA
- (4) DORA and SIB go LOW; flag indicates that the output stage of FIFOA is busy, shift-in of FIFOB is complete
- (5) DORA and SIB go HIGH; flag indicates that valid data is again available at FIFOA output stage, SIB is held HIGH, awaiting bubble-up of empty location.
- (6) DIRA goes HIGH; (bubble-up delay after  $\overline{SÖA}$  LOW) an empty location is present at input stage of FIFOA

**Fig 23. FIFO to FIFO communication; output timing under full condition**

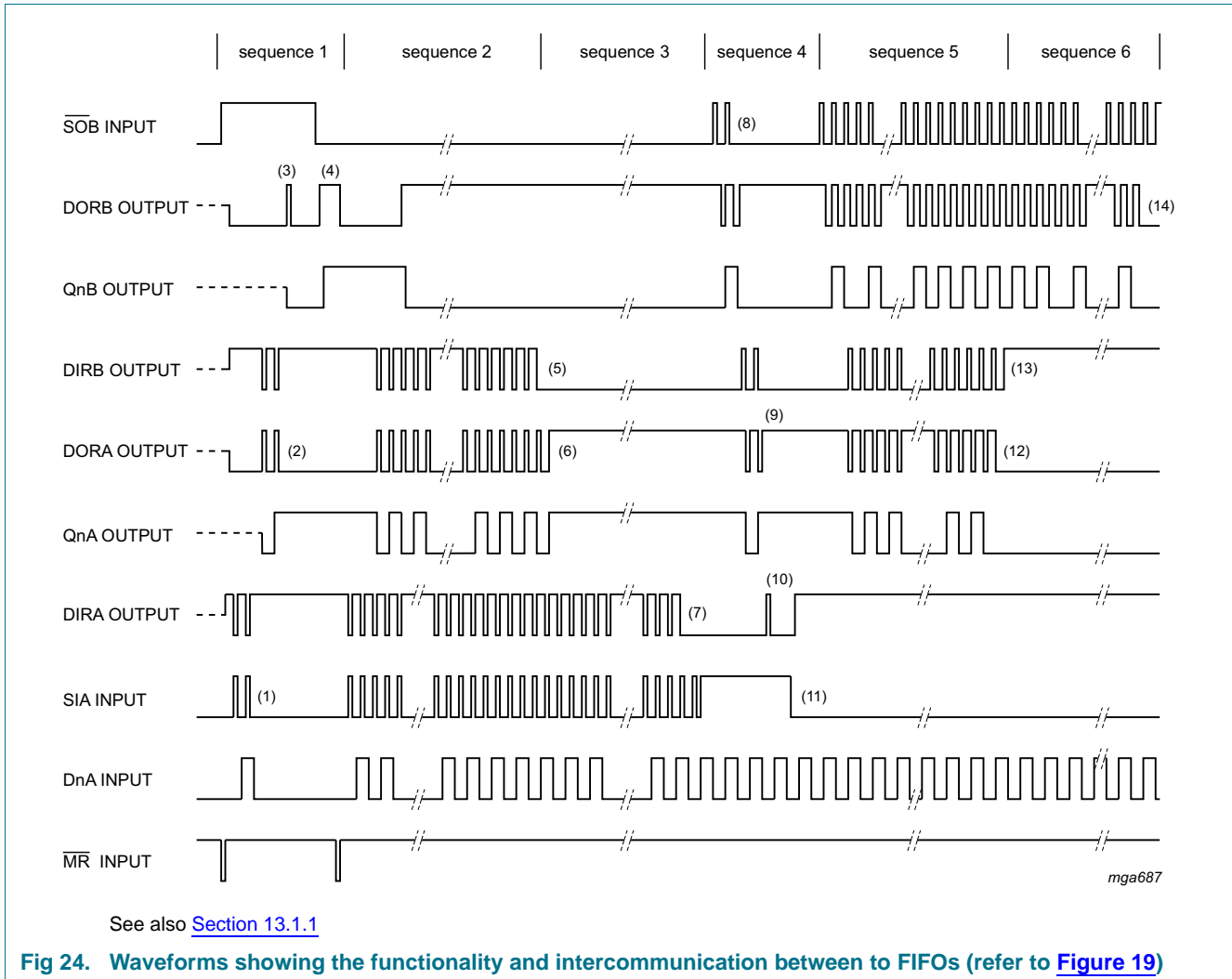

**13.1.1 Sequence 1 (both FIFOs empty, starting SHIFT-IN process)**

After an  $\overline{\text{MR}}$  pulse has been applied, FIFOA and FIFOB are empty. The DOR flags of FIFOA and FIFOB go LOW due to no valid data being present at the outputs. The DIR flags are set HIGH due to the FIFOs being ready to accept data.  $\overline{\text{SOB}}$  is held HIGH and two SIA pulses are applied (1). These pulses allow two data words to ripple through the output stage of FIFOA and the input stage of FIFOB (2). When data arrives at the output of FIFOB, a DORB pulse is generated (3). When  $\overline{\text{SOB}}$  goes LOW, the first bit is shifted out and a second bit ripples through to the output after which DORB goes high (4).

**13.1.2 Sequence 2 (FIFOB runs full)**

After the  $\overline{\text{MR}}$  pulse, a series of 64 SI pulses are applied. When 64 words are shifted in, DIRB remains LOW due to FIFOB being full (5). DORA goes LOW due to FIFOA being empty.

### 13.1.3 Sequence 3 (FIFOA runs full)

When 65 words are shifted in, DORA remains HIGH due to valid data remaining at the output of FIFOA. QnA remains HIGH, being the polarity of the 65<sup>th</sup> word (6). After the 128<sup>th</sup> SI pulse, DIR remains LOW and both FIFOs are full (7). Additional pulses have no effect.

### 13.1.4 Sequence 4 (both FIFOs full, starting SHIFT-OUT)

SIA is held HIGH and two  $\overline{\text{SOB}}$  pulses are applied (8). These pulses shift out two words and thus allow two empty locations to bubble-up to the input stage of FIFOB, and proceed to FIFOA (9). When the first empty location arrives at the input of FIFOA, a DIRA pulse is generated (10) and a new word is shifted into FIFOA. SIA is made LOW and now the second empty location reaches the input stage of FIFOA, after which DIRA remains HIGH (11).

### 13.1.5 Sequence 5 (FIFOA runs empty)

At the start of sequence 5 FIFOA contains 63 valid words due to two words being shifted out and one word being shifted in, in sequence 4. And additional series of  $\overline{\text{SOB}}$  pulses are applied. After 63  $\overline{\text{SOB}}$  pulses, all words from FIFOA are shifted in FIFOB. DORA remains LOW (12).

### 13.1.6 Sequence 6 (FIFOB runs empty)

After the next  $\overline{\text{SOB}}$  pulse, DIRB remains HIGH due to the input stage of FIFOB being empty. After another 63  $\overline{\text{SOB}}$  pulses, DORB remains LOW due to both FIFOs being empty (14). Additional  $\overline{\text{SOB}}$  pulses have no effect. The last word remains available at the output Qn.

14. Package outline

DIP16: plastic dual in-line package; 16 leads (300 mil)

SOT38-4

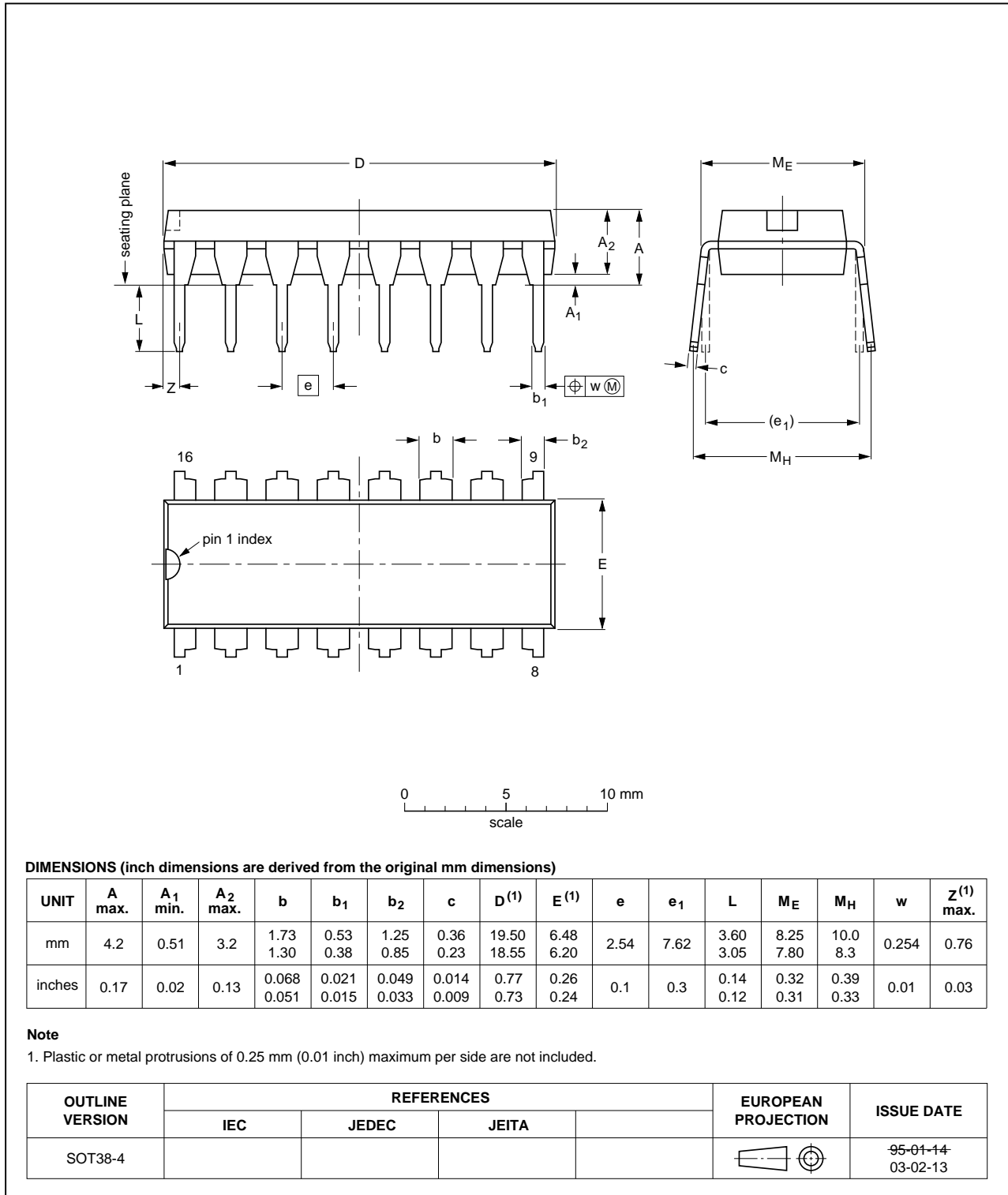

Fig 25. Package outline SOT38-4 (DIP16)

SO16: plastic small outline package; 16 leads; body width 3.9 mm

SOT109-1

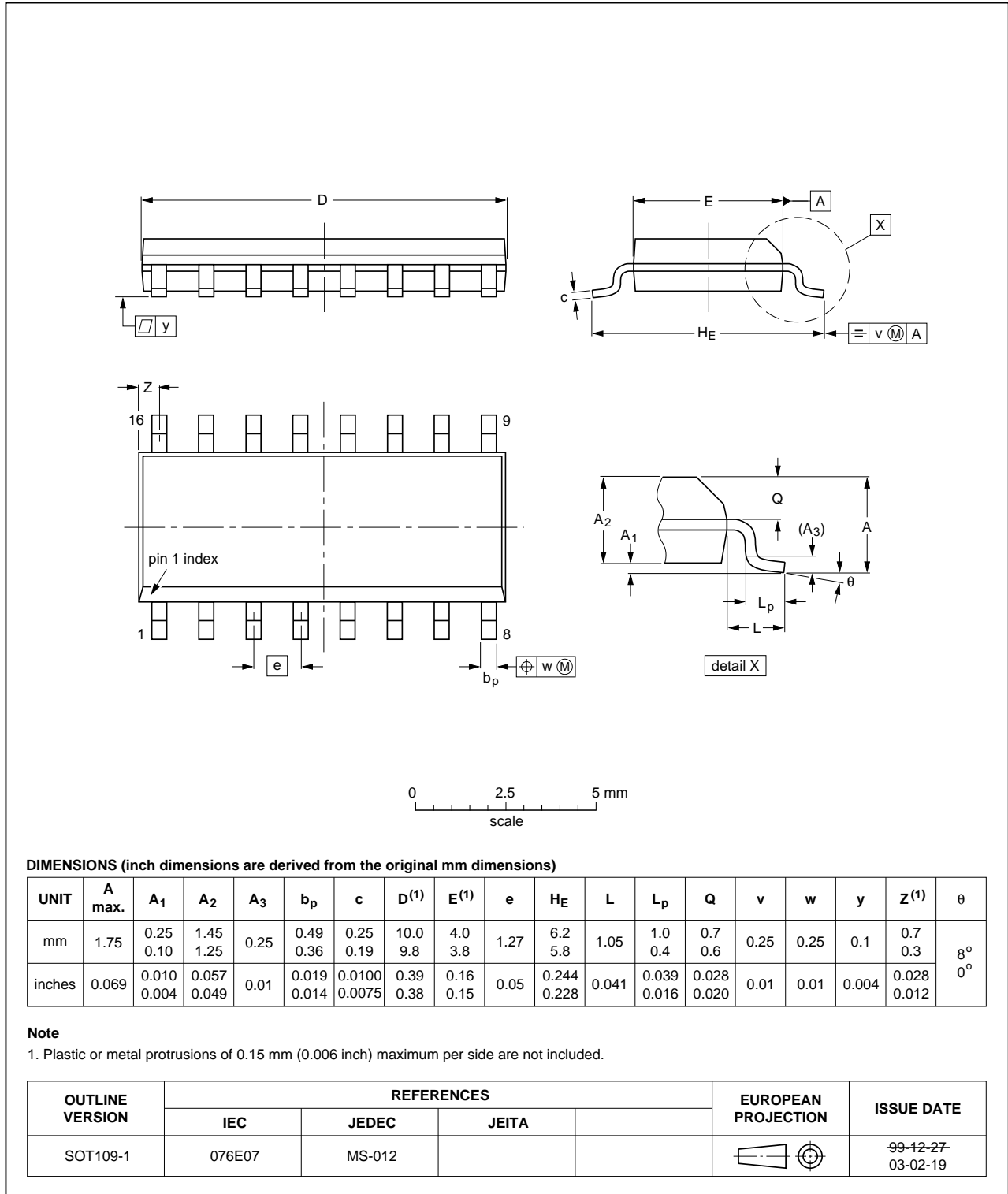

Fig 26. Package outline SOT109-1 (SO16)

## 15. Abbreviations

Table 9. Abbreviations

Acronym	Description
CMOS	Complementary Metal Oxide Semiconductor
ESD	ElectroStatic Discharge
HBM	Human Body Model
MM	Machine Model
TTL	Transistor-Transistor Logic
FIFO	First In First Out

## 16. Revision history

Table 10. Revision history

Document ID	Release date	Data sheet status	Change notice	Supersedes
74HC_HCT7403 v.4	20120924	Product data sheet	-	74HC_HCT7403_CNV v.3
Modifications:				
				<ul style="list-style-type: none"><li>The format of this data sheet has been redesigned to comply with the new identity guidelines of NXP Semiconductors.</li><li>Legal texts have been adapted to the new company name where appropriate.</li></ul>
74HC_HCT7403_CNV v.3	19970916	Product specification	-	-

## 17. Legal information

### 17.1 Data sheet status

Document status <sup>[1][2]</sup>	Product status <sup>[3]</sup>	Definition
Objective [short] data sheet	Development	This document contains data from the objective specification for product development.
Preliminary [short] data sheet	Qualification	This document contains data from the preliminary specification.
Product [short] data sheet	Production	This document contains the product specification.

[1] Please consult the most recently issued document before initiating or completing a design.

[2] The term 'short data sheet' is explained in section "Definitions".

[3] The product status of device(s) described in this document may have changed since this document was published and may differ in case of multiple devices. The latest product status information is available on the Internet at URL <http://www.nxp.com>.

### 17.2 Definitions

**Draft** — The document is a draft version only. The content is still under internal review and subject to formal approval, which may result in modifications or additions. NXP Semiconductors does not give any representations or warranties as to the accuracy or completeness of information included herein and shall have no liability for the consequences of use of such information.

**Short data sheet** — A short data sheet is an extract from a full data sheet with the same product type number(s) and title. A short data sheet is intended for quick reference only and should not be relied upon to contain detailed and full information. For detailed and full information see the relevant full data sheet, which is available on request via the local NXP Semiconductors sales office. In case of any inconsistency or conflict with the short data sheet, the full data sheet shall prevail.

**Product specification** — The information and data provided in a Product data sheet shall define the specification of the product as agreed between NXP Semiconductors and its customer, unless NXP Semiconductors and customer have explicitly agreed otherwise in writing. In no event however, shall an agreement be valid in which the NXP Semiconductors product is deemed to offer functions and qualities beyond those described in the Product data sheet.

### 17.3 Disclaimers

**Limited warranty and liability** — Information in this document is believed to be accurate and reliable. However, NXP Semiconductors does not give any representations or warranties, expressed or implied, as to the accuracy or completeness of such information and shall have no liability for the consequences of use of such information. NXP Semiconductors takes no responsibility for the content in this document if provided by an information source outside of NXP Semiconductors.

In no event shall NXP Semiconductors be liable for any indirect, incidental, punitive, special or consequential damages (including - without limitation - lost profits, lost savings, business interruption, costs related to the removal or replacement of any products or rework charges) whether or not such damages are based on tort (including negligence), warranty, breach of contract or any other legal theory.

Notwithstanding any damages that customer might incur for any reason whatsoever, NXP Semiconductors' aggregate and cumulative liability towards customer for the products described herein shall be limited in accordance with the *Terms and conditions of commercial sale* of NXP Semiconductors.

**Right to make changes** — NXP Semiconductors reserves the right to make changes to information published in this document, including without limitation specifications and product descriptions, at any time and without notice. This document supersedes and replaces all information supplied prior to the publication hereof.

**Suitability for use** — NXP Semiconductors products are not designed, authorized or warranted to be suitable for use in life support, life-critical or safety-critical systems or equipment, nor in applications where failure or malfunction of an NXP Semiconductors product can reasonably be expected to result in personal injury, death or severe property or environmental damage. NXP Semiconductors and its suppliers accept no liability for inclusion and/or use of NXP Semiconductors products in such equipment or applications and therefore such inclusion and/or use is at the customer's own risk.

**Applications** — Applications that are described herein for any of these products are for illustrative purposes only. NXP Semiconductors makes no representation or warranty that such applications will be suitable for the specified use without further testing or modification.

Customers are responsible for the design and operation of their applications and products using NXP Semiconductors products, and NXP Semiconductors accepts no liability for any assistance with applications or customer product design. It is customer's sole responsibility to determine whether the NXP Semiconductors product is suitable and fit for the customer's applications and products planned, as well as for the planned application and use of customer's third party customer(s). Customers should provide appropriate design and operating safeguards to minimize the risks associated with their applications and products.

NXP Semiconductors does not accept any liability related to any default, damage, costs or problem which is based on any weakness or default in the customer's applications or products, or the application or use by customer's third party customer(s). Customer is responsible for doing all necessary testing for the customer's applications and products using NXP Semiconductors products in order to avoid a default of the applications and the products or of the application or use by customer's third party customer(s). NXP does not accept any liability in this respect.

**Limiting values** — Stress above one or more limiting values (as defined in the Absolute Maximum Ratings System of IEC 60134) will cause permanent damage to the device. Limiting values are stress ratings only and (proper) operation of the device at these or any other conditions above those given in the Recommended operating conditions section (if present) or the Characteristics sections of this document is not warranted. Constant or repeated exposure to limiting values will permanently and irreversibly affect the quality and reliability of the device.

**Terms and conditions of commercial sale** — NXP Semiconductors products are sold subject to the general terms and conditions of commercial sale, as published at <http://www.nxp.com/profile/terms>, unless otherwise agreed in a valid written individual agreement. In case an individual agreement is concluded only the terms and conditions of the respective agreement shall apply. NXP Semiconductors hereby expressly objects to applying the customer's general terms and conditions with regard to the purchase of NXP Semiconductors products by customer.

**No offer to sell or license** — Nothing in this document may be interpreted or construed as an offer to sell products that is open for acceptance or the grant, conveyance or implication of any license under any copyrights, patents or other industrial or intellectual property rights.

**Export control** — This document as well as the item(s) described herein may be subject to export control regulations. Export might require a prior authorization from competent authorities.

**Non-automotive qualified products** — Unless this data sheet expressly states that this specific NXP Semiconductors product is automotive qualified, the product is not suitable for automotive use. It is neither qualified nor tested in accordance with automotive testing or application requirements. NXP Semiconductors accepts no liability for inclusion and/or use of non-automotive qualified products in automotive equipment or applications.

In the event that customer uses the product for design-in and use in automotive applications to automotive specifications and standards, customer (a) shall use the product without NXP Semiconductors' warranty of the product for such automotive applications, use and specifications, and (b) whenever customer uses the product for automotive applications beyond

NXP Semiconductors' specifications such use shall be solely at customer's own risk, and (c) customer fully indemnifies NXP Semiconductors for any liability, damages or failed product claims resulting from customer design and use of the product for automotive applications beyond NXP Semiconductors' standard warranty and NXP Semiconductors' product specifications.

**Translations** — A non-English (translated) version of a document is for reference only. The English version shall prevail in case of any discrepancy between the translated and English versions.

## 17.4 Trademarks

Notice: All referenced brands, product names, service names and trademarks are the property of their respective owners.

## 18. Contact information

For more information, please visit: <http://www.nxp.com>

For sales office addresses, please send an email to: [salesaddresses@nxp.com](mailto:salesaddresses@nxp.com)

19. Contents

<b>1</b>	<b>General description</b> . . . . .	<b>1</b>	17.1	Data sheet status . . . . .	32
<b>2</b>	<b>Features and benefits</b> . . . . .	<b>1</b>	17.2	Definitions . . . . .	32
<b>3</b>	<b>Applications</b> . . . . .	<b>1</b>	17.3	Disclaimers . . . . .	32
<b>4</b>	<b>Ordering information</b> . . . . .	<b>2</b>	17.4	Trademarks . . . . .	33
<b>5</b>	<b>Functional diagram</b> . . . . .	<b>2</b>	<b>18</b>	<b>Contact information</b> . . . . .	<b>33</b>
<b>6</b>	<b>Pinning information</b> . . . . .	<b>4</b>	<b>19</b>	<b>Contents</b> . . . . .	<b>34</b>
6.1	Pinning . . . . .	4			
6.2	Pin description . . . . .	4			
<b>7</b>	<b>Functional description</b> . . . . .	<b>5</b>			
7.1	Expanded format . . . . .	5			
7.1.1	Parallel expansion . . . . .	5			
7.1.2	Serial expansion . . . . .	5			
<b>8</b>	<b>Limiting values</b> . . . . .	<b>5</b>			
<b>9</b>	<b>Recommended operating conditions</b> . . . . .	<b>6</b>			
<b>10</b>	<b>Static characteristics</b> . . . . .	<b>6</b>			
<b>11</b>	<b>Dynamic characteristics</b> . . . . .	<b>8</b>			
<b>12</b>	<b>Waveforms</b> . . . . .	<b>13</b>			
12.1	Shifting in sequence FIFO empty to FIFO full . . . . .	13			
12.2	With FIFO full; SI held HIGH in anticipation of empty location . . . . .	14			
12.3	Master reset applied with FIFO full . . . . .	15			
12.4	SO input to DOR output propagation delay . . . . .	16			
12.5	With FIFO empty; SO is held HIGH in anticipation . . . . .	17			
12.6	Shift-in operation; high speed burst mode . . . . .	17			
12.7	Shift-out operation; high speed burst mode . . . . .	18			
12.8	Set-up and hold times . . . . .	18			
12.9	SO input to Qn outputs propagation delay . . . . .	19			
12.10	MR to SI recovery time . . . . .	19			
12.11	Enable and disable times . . . . .	20			
12.12	Test circuit for measuring switching times . . . . .	21			
<b>13</b>	<b>Application information</b> . . . . .	<b>22</b>			
13.1	Expanded format . . . . .	23			
13.1.1	Sequence 1 (both FIFOs empty, starting SHIFT-IN process) . . . . .	27			
13.1.2	Sequence 2 (FIFOB runs full) . . . . .	27			
13.1.3	Sequence 3 (FIFOA runs full) . . . . .	28			
13.1.4	Sequence 4 (both FIFOs full, starting SHIFT-OUT) . . . . .	28			
13.1.5	Sequence 5 (FIFOA runs empty) . . . . .	28			
13.1.6	Sequence 6 (FIFOB runs empty) . . . . .	28			
<b>14</b>	<b>Package outline</b> . . . . .	<b>29</b>			
<b>15</b>	<b>Abbreviations</b> . . . . .	<b>31</b>			
<b>16</b>	<b>Revision history</b> . . . . .	<b>31</b>			
<b>17</b>	<b>Legal information</b> . . . . .	<b>32</b>			

Please be aware that important notices concerning this document and the product(s) described herein, have been included in section 'Legal information'.



LittleDiode supplies new, hard to find or obsolete electronic components and semiconductors all over the world.

With over two million different components listed you are sure to find the part you need.

Feel free to visit us today at our online store:

[LittleDiode.com](http://LittleDiode.com)

Looking forward to providing you with the best possible service.