

# DATA SHEET

For a complete data sheet, please also download:

- The IC06 74HC/HCT/HCU/HCMOS Logic Family Specifications
- The IC06 74HC/HCT/HCU/HCMOS Logic Package Information
- The IC06 74HC/HCT/HCU/HCMOS Logic Package Outlines

## **74HC/HCT7597**

**8-bit shift register with input latches**

Product specification  
File under Integrated Circuits, IC06

December 1990

## 8-bit shift register with input latches

## 74HC/HCT7597

## FEATURES

- 8-bit parallel input latches
- Shift register has direct overriding load and clear
- Output capability: standard
- $I_{CC}$  category: MSI

## GENERAL DESCRIPTION

The 74HC/HCT7597 are high-speed Si-gate CMOS devices and are pin compatible with low power Schottky TTL (LSTTL). They are specified in compliance with JEDEC standard no. 7A.

The 74HC/HCT7597 both consist of an 8-bit storage latch feeding a parallel-in, serial-out 8-bit shift register.

When  $\overline{LE}$  is LOW, data at the  $D_n$  inputs enter the latches. In this condition the latches are transparent, i.e. a latch output will change state each time its corresponding D-input changes.

When  $\overline{LE}$  is HIGH the latches store the information that was present at the D-inputs, a set-up time preceding the LOW-to-HIGH transition of  $\overline{LE}$ .

The shift register has a positive edge-triggered clock, direct load (from storage) and clear inputs.

## QUICK REFERENCE DATA

GND = 0 V;  $T_{amb} = 25\text{ }^\circ\text{C}$ ;  $t_r = t_f = 6\text{ ns}$

SYMBOL	PARAMETER	CONDITIONS	TYPICAL		UNIT
			HC	HCT	
$t_{PHL}/t_{PLH}$	propagation delay	$C_L = 15\text{ pF}; V_{CC} = 5\text{ V}$			
	$SH_{CP}$ to Q		15	17	ns
	$\overline{LE}$ to Q		22	27	ns
	$\overline{PL}$ to Q		20	23	ns
	$D_7$ to Q		20	24	ns
$f_{max}$	maximum clock frequency $SH_{CP}$		99	79	MHz
$C_I$	input capacitance		3.5	3.5	pF
$C_{PD}$	power dissipation capacitance per package	notes 1, 2	29	30	pF

## Notes

1.  $C_{PD}$  is used to determine the dynamic power dissipation ( $P_D$  in  $\mu\text{W}$ ):

$$P_D = C_{PD} \times V_{CC}^2 \times f_i + \sum (C_L \times V_{CC}^2 \times f_o) \text{ where:}$$

$f_i$  = input frequency in MHz;  $f_o$  = output frequency in MHz

$\sum (C_L \times V_{CC}^2 \times f_o)$  = sum of outputs

$C_L$  = output load capacitance in pF;  $V_{CC}$  = supply voltage in V

2. For HC the condition is  $V_I = \text{GND to } V_{CC}$ ; for HCT the condition is  $V_I = \text{GND to } V_{CC} - 1.5\text{ V}$

## ORDERING INFORMATION

See "74HC/HCT/HCU/HCMOS Logic Package Information".

# 8-bit shift register with input latches

# 74HC/HCT7597

## PIN DESCRIPTION

PIN NO.	SYMBOL	NAME AND FUNCTION
8	GND	ground (0 V)
9	Q	serial data output
10	$\overline{MR}$	asynchronous reset input (active LOW)
11	SH <sub>CP</sub>	shift clock input (LOW-to-HIGH, edge-triggered)
12	$\overline{LE}$	latch enable input (active LOW)
13	$\overline{PL}$	parallel load input (active LOW)
14	D <sub>S</sub>	serial data input
15, 1, 2, 3, 4, 5, 6, 7	D <sub>0</sub> to D <sub>7</sub>	parallel data inputs
16	V <sub>CC</sub>	positive supply voltage

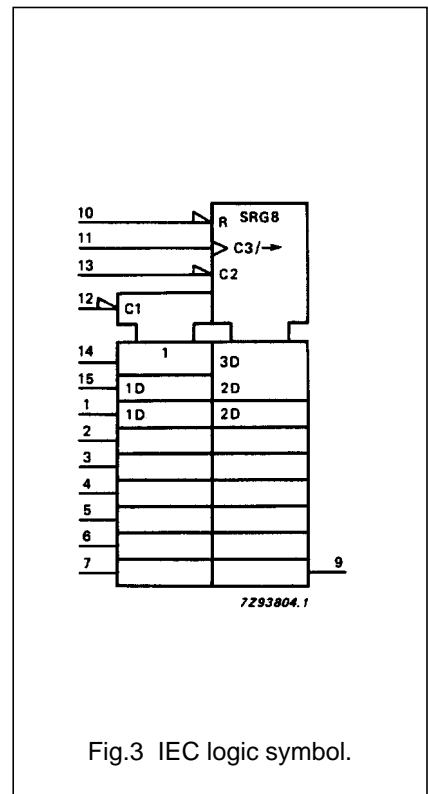
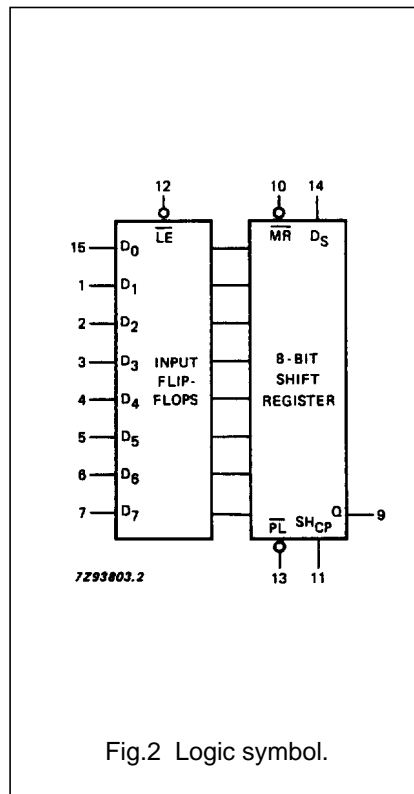
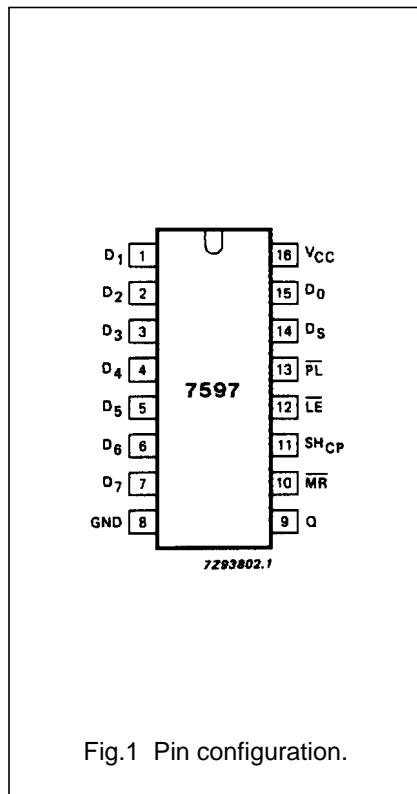

## 8-bit shift register with input latches

74HC/HCT7597

## FUNCTION TABLE

$\overline{LE}$	$SH_{CP}$	$\overline{PL}$	$\overline{MR}$	FUNCTION
L	X	X	X	data enabled to input latches (transparent)
H	X	X	X	data stored into latches (non-transparent)
X	X	L	H	data transferred from input latches to shift register
X	X	L	L	invalid logic, state of shift register indeterminate when signals removed
X	X	H	L	shift register cleared
X	↑	H	H	shift register clocked $Q_n = Q_{n-1}$ , $Q_0 = D_S$

## Notes

- H = HIGH voltage level  
L = LOW voltage level  
X = don't care  
↑ = LOW-to-HIGH CP transition

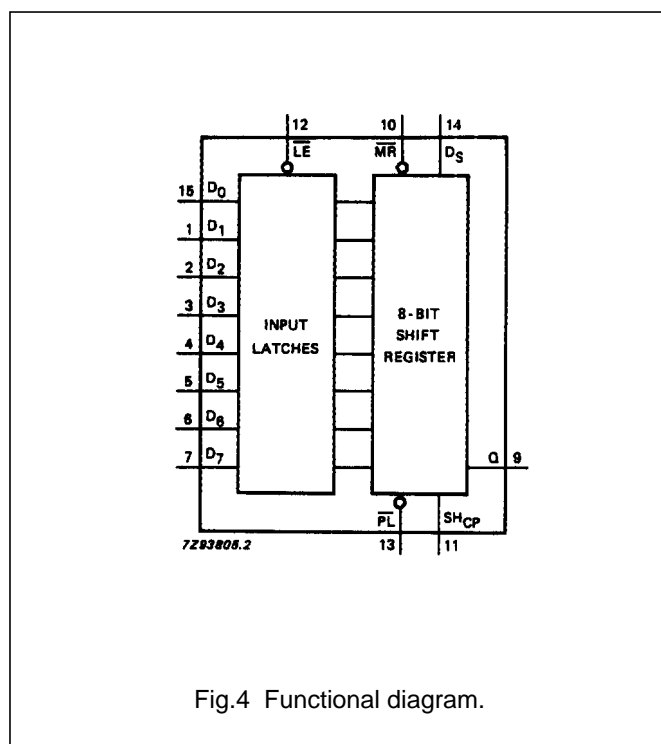

# 8-bit shift register with input latches

74HC/HCT7597

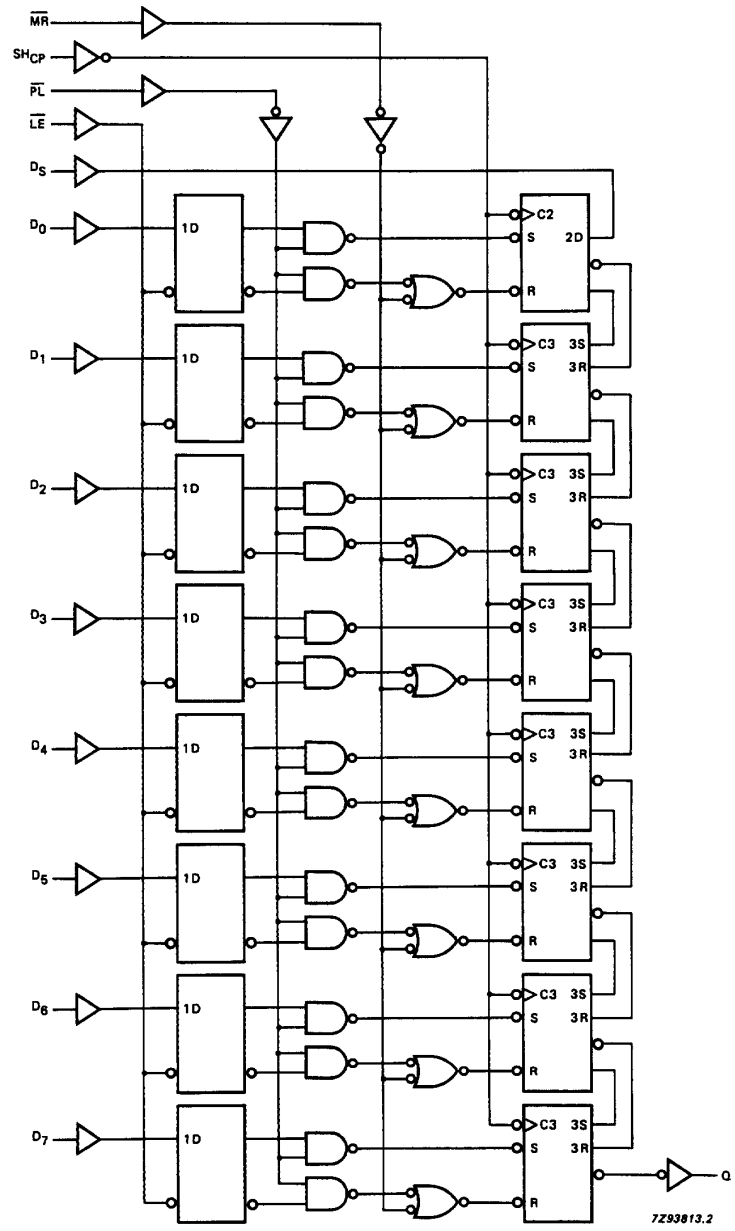

Fig.5 Logic diagram.

8-bit shift register with input latches

74HC/HCT7597

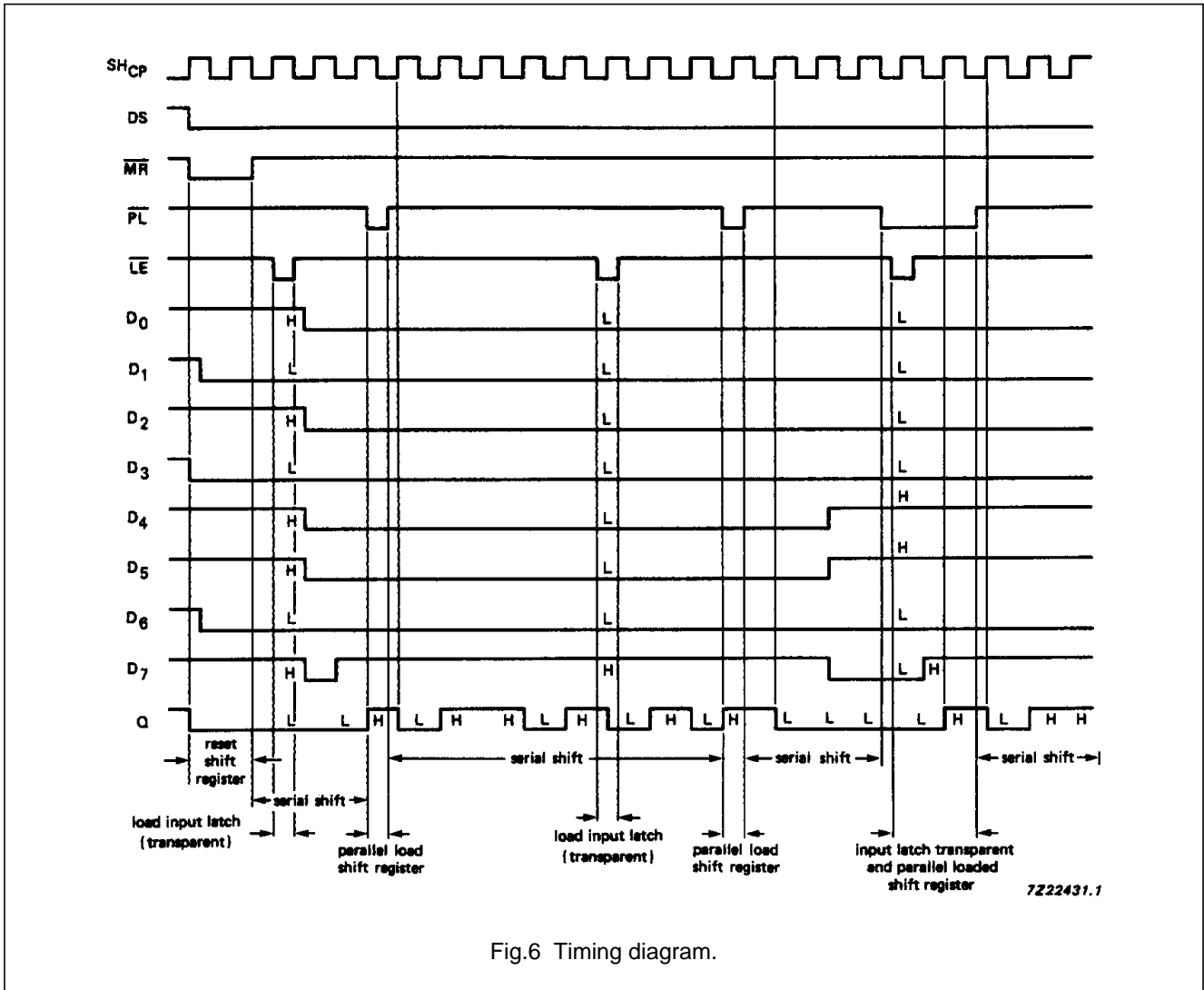

Fig.6 Timing diagram.

## 8-bit shift register with input latches

## 74HC/HCT7597

**DC CHARACTERISTICS FOR 74HC**

For the DC characteristics see *"74HC/HCT/HCU/HCMOS Logic Family Specifications"*.

Output capability: standard

I<sub>CC</sub> category: MSI

**AC CHARACTERISTICS FOR 74HC**

GND = 0 V; t<sub>r</sub> = t<sub>f</sub> = 6 ns; C<sub>L</sub> = 50 pF

SYMBOL	PARAMETER	T <sub>amb</sub> (°C)						UNIT	TEST CONDITIONS		
		74HC							V <sub>CC</sub> (V)	WAVEFORMS	
		+25			-40 to +85		-40 to +125				
		min.	typ.	max.	min.	max.	min.				max.
t <sub>PHL</sub> / t <sub>PLH</sub>	propagation delay SH <sub>CP</sub> to Q		50 18 14	175 35 30		220 44 37		265 53 45	ns	2.0 4.5 6.0	Fig.7
t <sub>PHL</sub>	propagation delay MR to Q		52 19 15	175 35 30		220 44 37		265 53 45	ns	2.0 4.5 6.0	Fig.7
t <sub>PHL</sub> / t <sub>PLH</sub>	propagation delay $\overline{\text{LE}}$ to Q		72 26 21	250 50 43		315 63 54		375 75 64	ns	2.0 4.5 6.0	Fig.7
t <sub>PHL</sub> / t <sub>PLH</sub>	propagation delay $\overline{\text{PL}}$ to Q		63 23 18	190 38 32		240 48 41		285 57 48	ns	2.0 4.5 6.0	Fig.7
t <sub>PHL</sub> / t <sub>PLH</sub>	propagation delay D <sub>7</sub> to Q		63 23 18	190 38 32		240 48 41		285 57 48	ns	2.0 4.5 6.0	Fig.7
t <sub>THL</sub> / t <sub>TLH</sub>	output transition time		19 7 6	75 15 13		95 19 16		110 22 19	ns	2.0 4.5 6.0	Fig.7
t <sub>w</sub>	SH <sub>CP</sub> pulse width HIGH or LOW	80 16 14	11 4 3		100 20 17		120 24 20		ns	2.0 4.5 6.0	Fig.7
t <sub>w</sub>	$\overline{\text{LE}}$ pulse width LOW	80 16 14	11 4 3		100 20 17		120 24 20		ns	2.0 4.5 6.0	Fig.7
t <sub>w</sub>	$\overline{\text{MR}}$ pulse width LOW	80 16 14	17 6 5		100 20 17		120 24 20		ns	2.0 4.5 6.0	Fig.7
t <sub>w</sub>	$\overline{\text{PL}}$ pulse width LOW	80 16 14	17 6 5		100 20 17		120 24 20		ns	2.0 4.5 6.0	Fig.7
t <sub>rem</sub>	removal time $\overline{\text{MR}}$ to SH <sub>CP</sub>	50 10 9	-3 -1 -1		65 13 11		75 15 13		ns	2.0 4.5 6.0	Fig.7

## 8-bit shift register with input latches

## 74HC/HCT7597

SYMBOL	PARAMETER	T <sub>amb</sub> (°C)							UNIT	TEST CONDITIONS	
		74HC								V <sub>CC</sub> (V)	WAVEFORMS
		+25			-40 to +85		-40 to +125				
		min.	typ.	max.	min.	max.	min.	max.			
t <sub>rem</sub>	removal time MR to PL	100 20 17	22 8 6		125 25 21		150 30 26		ns	2.0 4.5 6.0	Fig.7
t <sub>su</sub>	set-up time D <sub>n</sub> to LE	80 16 14	6 2 2		100 20 17		120 24 20		ns	2.0 4.5 6.0	Fig.7
t <sub>su</sub>	set-up time D <sub>S</sub> to SH <sub>CP</sub>	80 16 14	11 4 3		100 20 17		120 24 20		ns	2.0 4.5 6.0	Fig.7
t <sub>su</sub>	set-up time PL to SH <sub>CP</sub>	80 16 14	8 3 2		100 20 17		120 24 20		ns	2.0 4.5 6.0	Fig.7
t <sub>h</sub>	hold time D <sub>n</sub> to LE	4 4 4	-3 -1 -1		4 4 4		4 4 4		ns	2.0 4.5 6.0	Fig.7
t <sub>h</sub>	hold time D <sub>S</sub> to SH <sub>CP</sub>	2 2 2	-8 -3 -2		2 2 2		2 2 2		ns	2.0 4.5 6.0	Fig.7
t <sub>h</sub>	hold time PL to SH <sub>CP</sub>	2 2 2	-8 -3 -2		2 2 2		2 2 2		ns	2.0 4.5 6.0	Fig.7
f <sub>max</sub>	maximum pulse frequency SH <sub>CP</sub>	6.0 30 35	30 90 107		4.8 24 28		4.0 20 24		MHz	2.0 4.5 6.0	Fig.7

## 8-bit shift register with input latches

## 74HC/HCT7597

**DC CHARACTERISTICS FOR 74HCT**

For the DC characteristics see *"74HC/HCT/HCU/HCMOS Logic Family Specifications"*.

Output capability: standard

$I_{CC}$  category: MSI

**Note to HCT types**

The value of additional quiescent supply current ( $\Delta I_{CC}$ ) for a unit load of 1 is given in the family specifications.

To determine  $\Delta I_{CC}$  per input, multiply this value by the unit load coefficient shown in the table below.

INPUT	UNIT LOAD COEFFICIENT
$D_S$	0.25
$D_n$	0.40
$\overline{PL}$ , $\overline{MR}$	1.50
$\overline{LE}$ , $SH_{CP}$	1.50

**AC CHARACTERISTICS FOR 74HCT**

GND = 0 V;  $t_r = t_f = 6$  ns;  $C_L = 50$  pF

SYMBOL	PARAMETER	$T_{amb}$ (°C)								UNIT	TEST CONDITIONS	
		74HCT									$V_{CC}$ (V)	WAVEFORMS
		+25			-40 to +85		-40 to +125					
		min.	typ.	max.	min.	max.	min.	max.				
$t_{PHL}/t_{PLH}$	propagation delay $SH_{CP}$ to Q		20	35		44		53	ns	4.5	Fig.7	
$t_{PHL}$	propagation delay $\overline{MR}$ to Q		25	42		53		63	ns	4.5	Fig.7	
$t_{PHL}/t_{PLH}$	propagation delay $\overline{LE}$ to Q		31	53		66		80	ns	4.5	Fig.7	
$t_{PHL}/t_{PLH}$	propagation delay $\overline{PL}$ to Q		27	46		58		69	ns	4.5	Fig.7	
$t_{PHL}/t_{PLH}$	propagation delay $D_7$ to Q		28	49		61		74	ns	4.5	Fig.7	
$t_{THL}/t_{TLH}$	output transition time		7	15		19		22	ns	4.5	Fig.7	
$t_W$	$SH_{CP}$ pulse width HIGH or LOW	16	6		20		24		ns	4.5	Fig.7	
$t_W$	$\overline{LE}$ pulse width LOW	16	7		20		24		ns	4.5	Fig.7	
$t_W$	$\overline{MR}$ pulse width LOW	20	11		25		30		ns	4.5	Fig.7	
$t_W$	$\overline{PL}$ pulse width LOW	18	9		23		27		ns	4.5	Fig.7	
$t_{rem}$	removal time $\overline{MR}$ to $SH_{CP}$	10	-1		13		15		ns	4.5	Fig.7	
$t_{rem}$	removal time $\overline{MR}$ to $\overline{PL}$	20	9		25		30		ns	4.5	Fig.7	

## 8-bit shift register with input latches

## 74HC/HCT7597

SYMBOL	PARAMETER	T <sub>amb</sub> (°C)							UNIT	TEST CONDITIONS	
		74HCT								V <sub>CC</sub> (V)	WAVEFORMS
		+25			-40 to +85		-40 to +125				
		min.	typ.	max.	min.	max.	min.	max.			
t <sub>su</sub>	set-up time D <sub>n</sub> to LE	16	5		20		24		ns	4.5	Fig.7
t <sub>su</sub>	set-up time D <sub>S</sub> to SH <sub>CP</sub>	16	5		20		24		ns	4.5	Fig.7
t <sub>su</sub>	set-up time PL to SH <sub>CP</sub>	16	3		20		24		ns	4.5	Fig.7
t <sub>h</sub>	hold time D <sub>n</sub> to LE	4	-2		4		4		ns	4.5	Fig.7
t <sub>h</sub>	hold time D <sub>S</sub> to SH <sub>CP</sub>	2	-4		2		2		ns	4.5	Fig.7
t <sub>h</sub>	hold time PL to SH <sub>CP</sub>	2	-3		2		2		ns	4.5	Fig.7
f <sub>max</sub>	maximum pulse frequency SH <sub>CP</sub>	30	72		24		20		MHz	4.5	Fig.7

8-bit shift register with input latches

74HC/HCT7597

AC WAVEFORMS

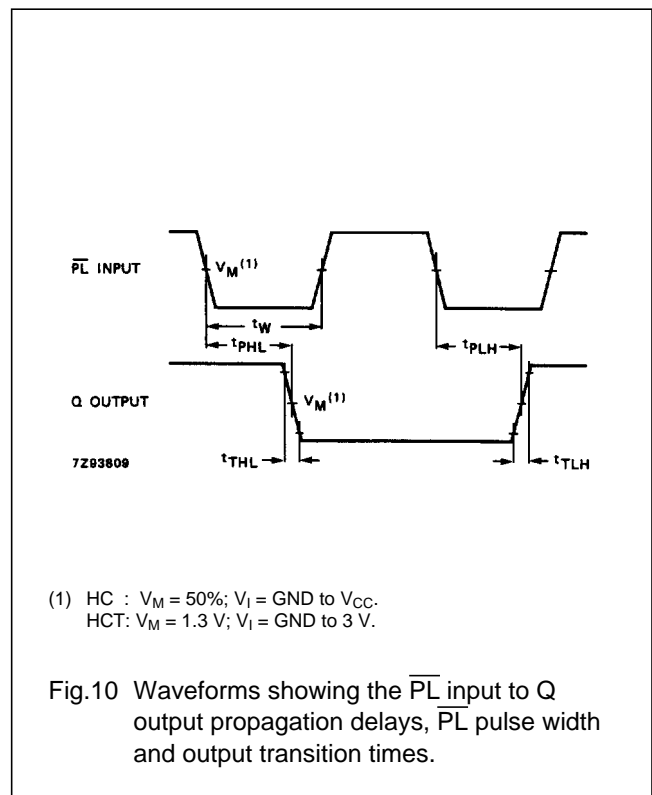
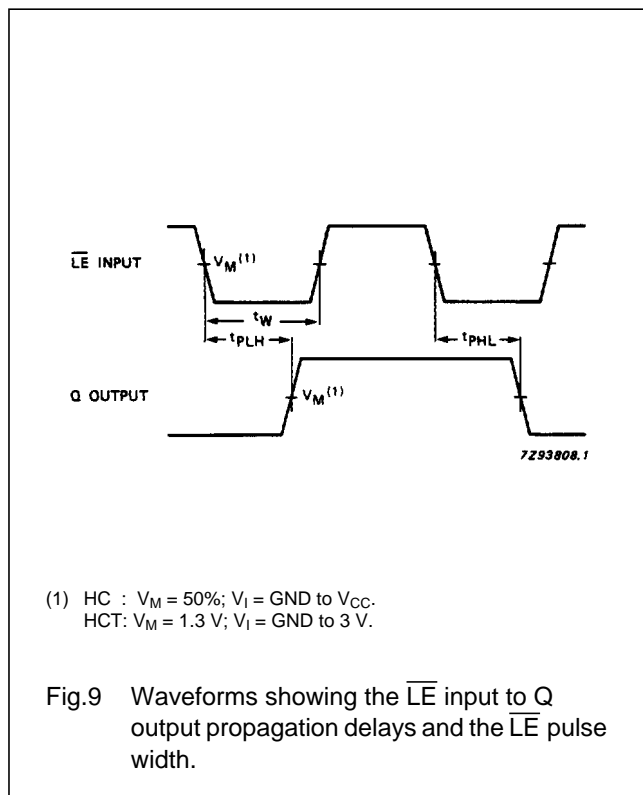
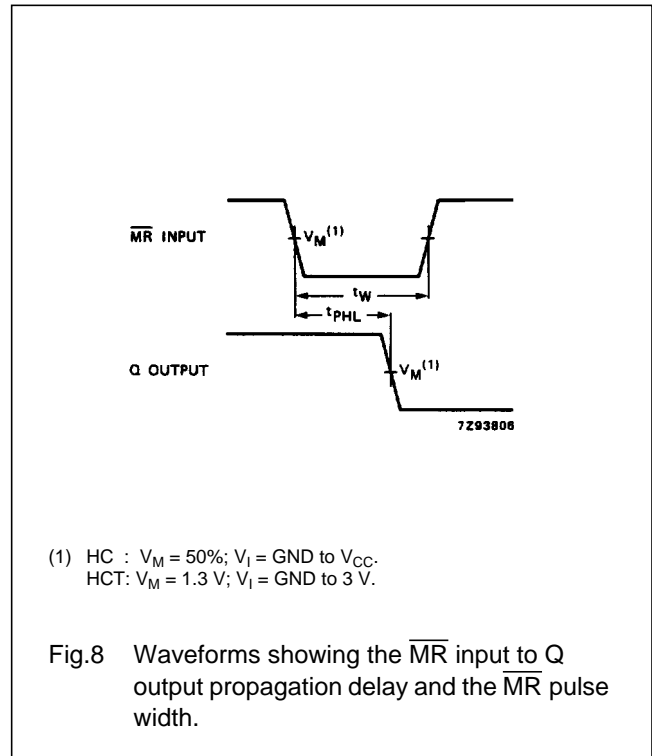
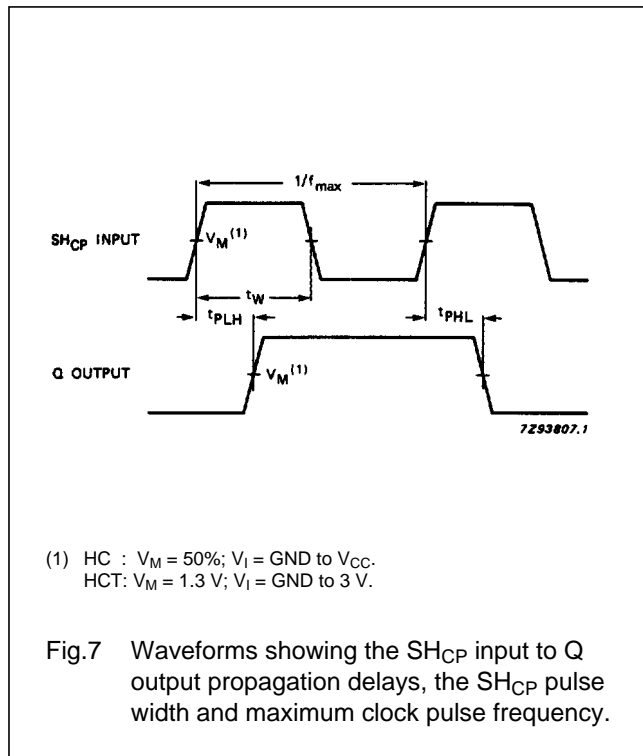

8-bit shift register with input latches

74HC/HCT7597

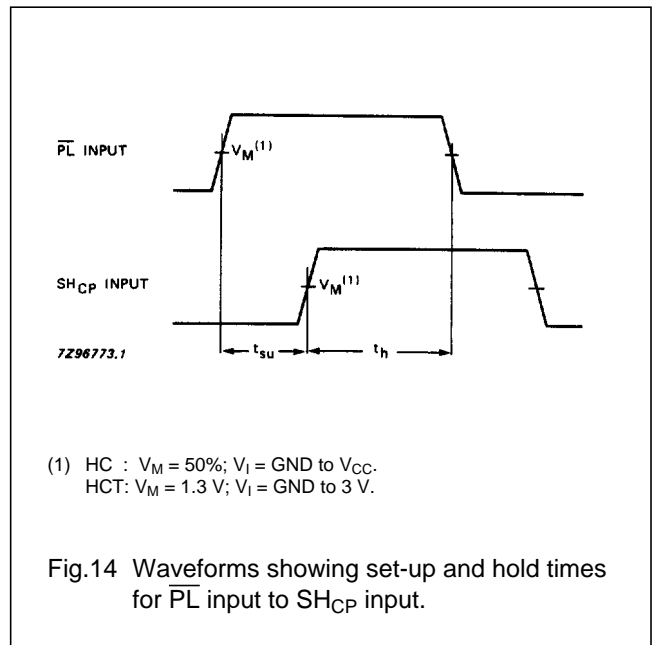
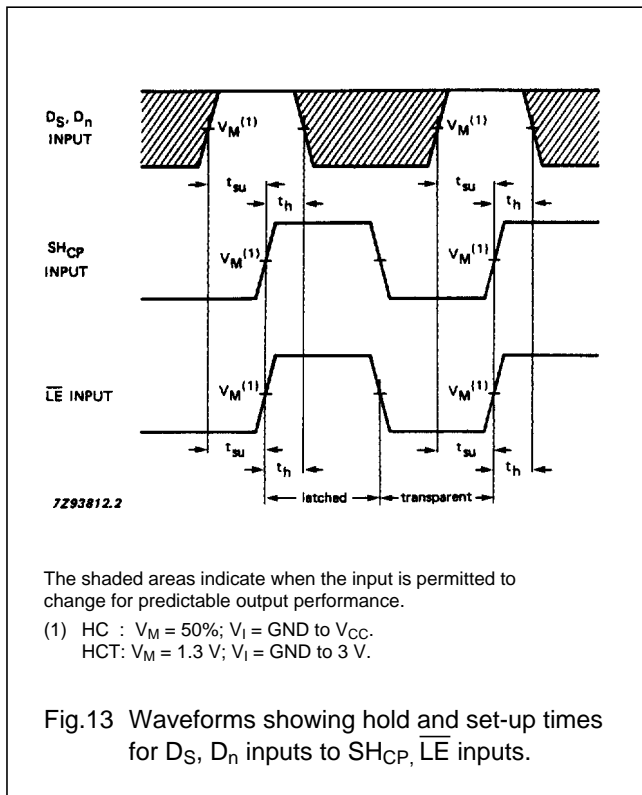
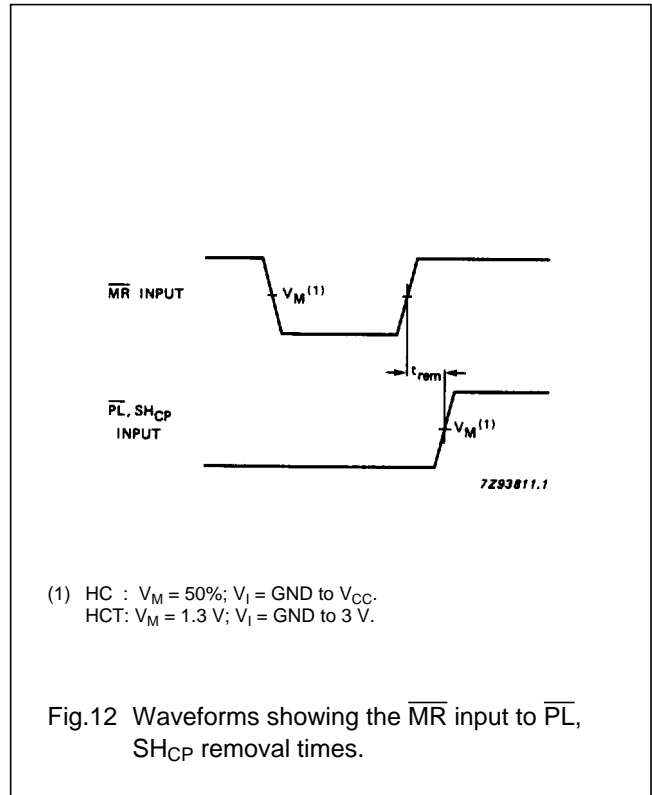
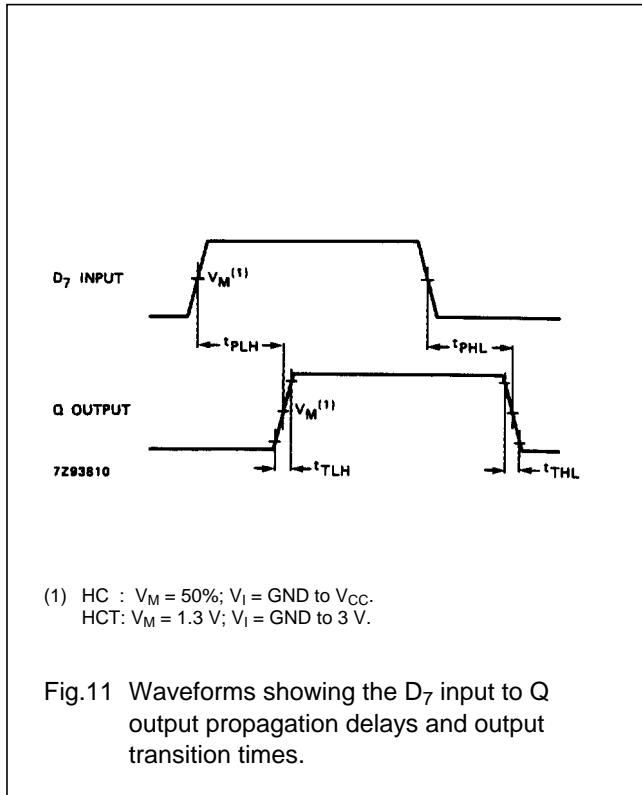

PACKAGE OUTLINES

See "74HC/HCT/HCU/HCMOS Logic Package Outlines".



LittleDiode supplies new, hard to find or obsolete electronic components and semiconductors all over the world.

With over two million different components listed you are sure to find the part you need.

Feel free to visit us today at our online store:

[LittleDiode.com](http://LittleDiode.com)

Looking forward to providing you with the best possible service.