

# DATA SHEET

**74LV126**

Quad buffer/line driver (3-State)

Product specification  
Supersedes data of 1997 Feb 03  
IC24 Data Handbook

1998 Apr 28

## Quad buffer/line driver (3-State)

74LV126

## FEATURES

- Wide operating voltage: 1.0 to 5.5 V
- Optimized for low voltage applications: 1.0 to 3.6 V
- Accepts TTL input levels between  $V_{CC} = 2.7$  V and  $V_{CC} = 3.6$  V
- Typical  $V_{OLP}$  (output ground bounce)  $< 0.8$  V at  $V_{CC} = 3.3$  V,  $T_{amb} = 25^{\circ}\text{C}$
- Typical  $V_{OHV}$  (output  $V_{OH}$  undershoot)  $> 2$  V at  $V_{CC} = 3.3$  V,  $T_{amb} = 25^{\circ}\text{C}$
- Output capability: bus driver
- $I_{CC}$  category: MSI

## DESCRIPTION

The 74LV126 is a low-voltage Si-gate CMOS device that is pin and function compatible with 74HC/HCT126.

The 74LV126 consists of four non-inverting buffers/line drivers with 3-state outputs. The 3-state outputs (nY) are controlled by the output enable input (nOE). A LOW at nOE causes the outputs to assume a high impedance OFF-state.

## QUICK REFERENCE DATA

GND = 0 V;  $T_{amb} = 25^{\circ}\text{C}$ ;  $t_r = t_f \leq 2.5$  ns

SYMBOL	PARAMETER	CONDITIONS	TYPICAL	UNIT
$t_{PHL}/t_{PLH}$	Propagation delay nA to nY	$C_L = 15$ pF; $V_{CC} = 3.3$ V	9	ns
$C_I$	Input capacitance		3.5	pF
$C_{PD}$	Power dissipation capacitance per buffer	$V_{CC} = 3.3$ V; $V_I = \text{GND to } V_{CC}^1$	23	pF

## NOTE:

1.  $C_{PD}$  is used to determine the dynamic power dissipation ( $P_D$  in  $\mu\text{W}$ )  
 $P_D = C_{PD} \times V_{CC}^2 \times f_i + \sum (C_L \times V_{CC}^2 \times f_o)$  where:  
 $f_i$  = input frequency in MHz;  $C_L$  = output load capacitance in pF;  
 $f_o$  = output frequency in MHz;  $V_{CC}$  = supply voltage in V;  
 $\sum (C_L \times V_{CC}^2 \times f_o)$  = sum of the outputs.

## ORDERING INFORMATION

PACKAGES	TEMPERATURE RANGE	OUTSIDE NORTH AMERICA	NORTH AMERICA	PKG. DWG. #
14-Pin Plastic DIL	$-40^{\circ}\text{C}$ to $+125^{\circ}\text{C}$	74LV126 N	74LV126 N	SOT27-1
14-Pin Plastic SO	$-40^{\circ}\text{C}$ to $+125^{\circ}\text{C}$	74LV126 D	74LV126 D	SOT108-1
14-Pin Plastic SSOP Type II	$-40^{\circ}\text{C}$ to $+125^{\circ}\text{C}$	74LV126 DB	74LV126 DB	SOT337-1
14-Pin Plastic TSSOP Type I	$-40^{\circ}\text{C}$ to $+125^{\circ}\text{C}$	74LV126 PW	74LV126PW DH	SOT402-1

## PIN DESCRIPTION

PIN NUMBER	SYMBOL	FUNCTION
1, 4, 10, 13	1OE – 4OE	Output enable inputs (active HIGH)
2, 5, 9, 12	1A – 4A	Data inputs
3, 6, 8, 11	1Y – 4Y	Data outputs
7	GND	Ground (0 V)
14	$V_{CC}$	Positive supply voltage

## FUNCTION TABLE

INPUTS		OUTPUTS
nOE	nA	nY
H	L	L
H	H	H
L	X	Z

## NOTES:

- H = HIGH voltage level  
 L = LOW voltage level  
 X = don't care  
 Z = high impedance OFF-state

# Quad buffer/line driver (3-State)

# 74LV126

### PIN CONFIGURATION

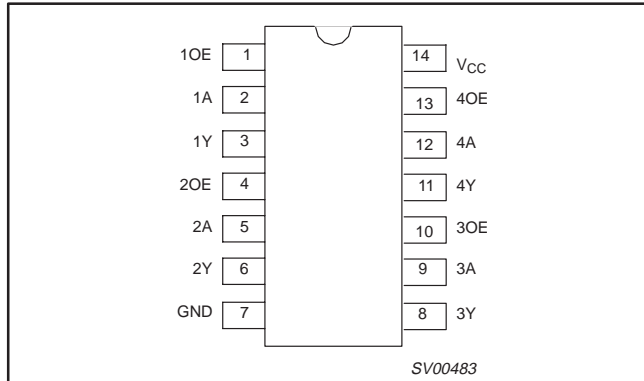

### LOGIC SYMBOL

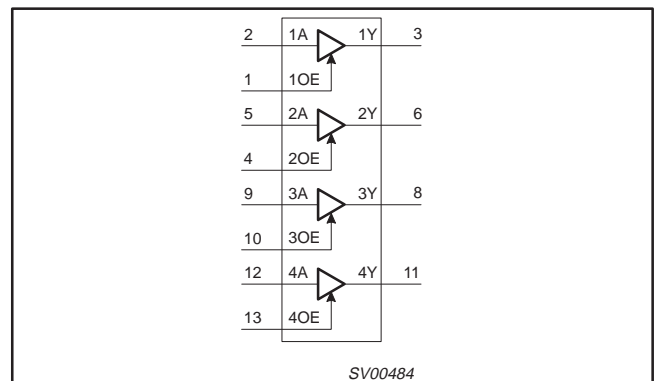

### LOGIC SYMBOL (IEEE/IEC)

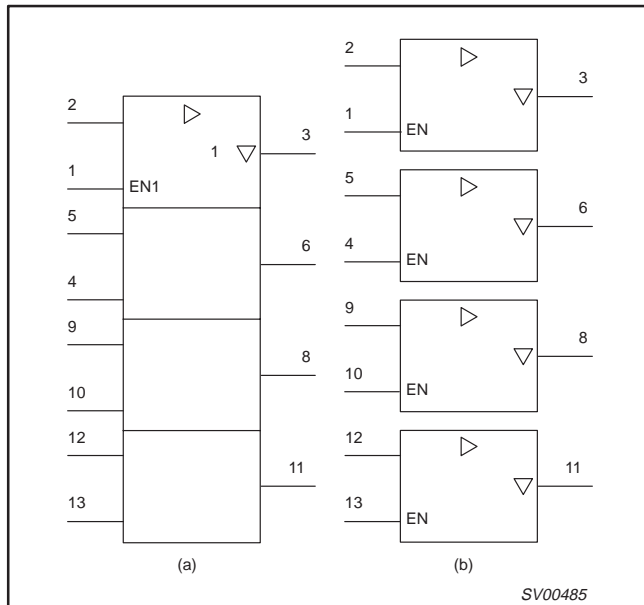

### LOGIC DIAGRAM (ONE GATE)

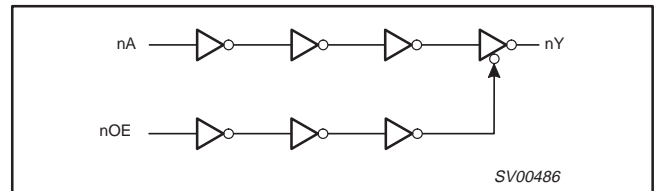

### RECOMMENDED OPERATING CONDITIONS

SYMBOL	PARAMETER	CONDITIONS	MIN	TYP	MAX	UNIT
$V_{CC}$	DC supply voltage	See Note 1	1.0	3.3	5.5	V
$V_I$	Input voltage		0	–	$V_{CC}$	V
$V_O$	Output voltage		0	–	$V_{CC}$	V
$T_{amb}$	Operating ambient temperature range in free air	See DC and AC characteristics	–40 –40		+85 +125	°C
$t_r, t_f$	Input rise and fall times	$V_{CC} = 1.0V$ to $2.0V$ $V_{CC} = 2.0V$ to $2.7V$ $V_{CC} = 2.7V$ to $3.6V$ $V_{CC} = 3.6V$ to $5.5V$	– – – –	– – – –	500 200 100 50	ns/V

**NOTE:**

1. The LV is guaranteed to function down to  $V_{CC} = 1.0V$  (input levels GND or  $V_{CC}$ ); DC characteristics are guaranteed from  $V_{CC} = 1.2V$  to  $V_{CC} = 5.5V$ .

## Quad buffer/line driver (3-State)

74LV126

**ABSOLUTE MAXIMUM RATINGS<sup>1, 2</sup>**

In accordance with the Absolute Maximum Rating System (IEC 134).

Voltages are referenced to GND (ground = 0 V).

SYMBOL	PARAMETER	CONDITIONS	RATING	UNIT
$V_{CC}$	DC supply voltage		-0.5 to +7.0	V
$\pm I_{IK}$	DC input diode current	$V_I < -0.5$ or $V_I > V_{CC} + 0.5V$	20	mA
$\pm I_{OK}$	DC output diode current	$V_O < -0.5$ or $V_O > V_{CC} + 0.5V$	50	mA
$\pm I_O$	DC output source or sink current – bus driver outputs	$-0.5V < V_O < V_{CC} + 0.5V$	35	mA
$\pm I_{GND}$ , $\pm I_{CC}$	DC $V_{CC}$ or GND current for types with – bus driver outputs		70	mA
$T_{stg}$	Storage temperature range		-65 to +150	°C
$P_{TOT}$	Power dissipation per package – plastic DIL – plastic mini-pack (SO) – plastic shrink mini-pack (SSOP and TSSOP)	for temperature range: -40 to +125°C above +70°C derate linearly with 12 mW/K above +70°C derate linearly with 8 mW/K above +60°C derate linearly with 5.5 mW/K	750 500 400	mW

**NOTES:**

- Stresses beyond those listed may cause permanent damage to the device. These are stress ratings only and functional operation of the device at these or any other conditions beyond those indicated under “recommended operating conditions” is not implied. Exposure to absolute-maximum-rated conditions for extended periods may affect device reliability.
- The input and output voltage ratings may be exceeded if the input and output current ratings are observed.

**DC ELECTRICAL CHARACTERISTICS**

Over recommended operating conditions, voltages are referenced to GND (ground = 0 V)

SYMBOL	PARAMETER	TEST CONDITIONS	LIMITS					UNIT
			-40°C to +85°C			-40°C to +125°C		
			MIN	TYP <sup>1</sup>	MAX	MIN	MAX	
$V_{IH}$	HIGH level Input voltage	$V_{CC} = 1.2 V$	0.9			0.9		V
		$V_{CC} = 2.0 V$	1.4			1.4		
		$V_{CC} = 2.7$ to $3.6 V$	2.0			2.0		
		$V_{CC} = 4.5$ to $5.5 V$	$0.7 * V_{CC}$			$0.7 * V_{CC}$		
$V_{IL}$	LOW level Input voltage	$V_{CC} = 1.2 V$			0.3		0.3	V
		$V_{CC} = 2.0 V$			0.6		0.6	
		$V_{CC} = 2.7$ to $3.6 V$			0.8		0.8	
		$V_{CC} = 4.5$ to $5.5$			$0.3 * V_{CC}$		$0.3 * V_{CC}$	
$V_{OH}$	HIGH level output voltage; all outputs	$V_{CC} = 1.2 V$ ; $V_I = V_{IH}$ or $V_{IL}$ ; $-I_O = 100\mu A$		1.2				V
		$V_{CC} = 2.0 V$ ; $V_I = V_{IH}$ or $V_{IL}$ ; $-I_O = 100\mu A$	1.8	2.0		1.8		
		$V_{CC} = 2.7 V$ ; $V_I = V_{IH}$ or $V_{IL}$ ; $-I_O = 100\mu A$	2.5	2.7		2.5		
		$V_{CC} = 3.0 V$ ; $V_I = V_{IH}$ or $V_{IL}$ ; $-I_O = 100\mu A$	2.8	3.0		2.8		
		$V_{CC} = 4.5 V$ ; $V_I = V_{IH}$ or $V_{IL}$ ; $-I_O = 100\mu A$	4.3	4.5		4.3		
$V_{OH}$	HIGH level output voltage; BUS driver outputs	$V_{CC} = 3.0 V$ ; $V_I = V_{IH}$ or $V_{IL}$ ; $-I_O = 8mA$	2.40	2.82		2.20		V
		$V_{CC} = 4.5 V$ ; $V_I = V_{IH}$ or $V_{IL}$ ; $-I_O = 16mA$	3.60	4.20		3.50		
$V_{OL}$	LOW level output voltage; all outputs	$V_{CC} = 1.2 V$ ; $V_I = V_{IH}$ or $V_{IL}$ ; $I_O = 100\mu A$		0				V
		$V_{CC} = 2.0 V$ ; $V_I = V_{IH}$ or $V_{IL}$ ; $I_O = 100\mu A$		0	0.2		0.2	
		$V_{CC} = 2.7 V$ ; $V_I = V_{IH}$ or $V_{IL}$ ; $I_O = 100\mu A$		0	0.2		0.2	
		$V_{CC} = 3.0 V$ ; $V_I = V_{IH}$ or $V_{IL}$ ; $I_O = 100\mu A$		0	0.2		0.2	
		$V_{CC} = 4.5 V$ ; $V_I = V_{IH}$ or $V_{IL}$ ; $I_O = 100\mu A$		0	0.2		0.2	

## Quad buffer/line driver (3-State)

74LV126

**DC ELECTRICAL CHARACTERISTICS (Continued)**

Over recommended operating conditions, voltages are referenced to GND (ground = 0 V)

SYMBOL	PARAMETER	TEST CONDITIONS	LIMITS					UNIT
			-40°C to +85°C			-40°C to +125°C		
			MIN	TYP <sup>1</sup>	MAX	MIN	MAX	
V <sub>OL</sub>	LOW level output voltage; BUS driver outputs	V <sub>CC</sub> = 3.0 V; V <sub>I</sub> = V <sub>IH</sub> or V <sub>IL</sub> ; I <sub>O</sub> = 8mA		0.20	0.40		0.50	V
		V <sub>CC</sub> = 4.5 V; V <sub>I</sub> = V <sub>IH</sub> or V <sub>IL</sub> ; I <sub>O</sub> = 16mA		0.35	0.55		0.65	
I <sub>I</sub>	Input leakage current	V <sub>CC</sub> = 5.5 V; V <sub>I</sub> = V <sub>CC</sub> or GND			1.0		1.0	μA
I <sub>oz</sub>	3-State output OFF-state current	V <sub>CC</sub> = 5.5 V; V <sub>I</sub> = V <sub>IH</sub> or V <sub>IL</sub> ; V <sub>O</sub> = V <sub>CC</sub> or GND			5		10	μA
I <sub>CC</sub>	Quiescent supply current; MSI	V <sub>CC</sub> = 5.5 V; V <sub>I</sub> = V <sub>CC</sub> or GND; I <sub>O</sub> = 0			20.0		160	μA
ΔI <sub>CC</sub>	Additional quiescent supply current per input	V <sub>CC</sub> = 2.7 V to 3.6 V; V <sub>I</sub> = V <sub>CC</sub> - 0.6 V			500		850	μA

**NOTE:**1. All typical values are measured at T<sub>amb</sub> = 25°C.**AC CHARACTERISTICS**GND = 0V; t<sub>r</sub> = t<sub>f</sub> ≤ 2.5ns; C<sub>L</sub> = 50pF; R<sub>L</sub> = 500Ω

SYMBOL	PARAMETER	WAVEFORM	CONDITION	LIMITS					UNIT
				-40 to +85 °C			-40 to +125 °C		
				MIN	TYP <sup>1</sup>	MAX	MIN	MAX	
t <sub>PHL</sub> /t <sub>PLH</sub>	Propagation delay nA to nY	Figures 1, 2	V <sub>CC</sub> (V)						ns
			1.2		55				
			2.0		19	24		31	
			2.7		14	18		23	
			3.0 to 3.6		10 <sup>2</sup>	14		18	
4.5 to 5.5			12		15				
t <sub>PZH</sub> /t <sub>PZL</sub>	3-state output enable time nOE to nY	Figures 1, 2	V <sub>CC</sub> (V)						ns
			1.2		75				
			2.0		26	31		39	
			2.7		19	23		29	
			3.0 to 3.6		14 <sup>2</sup>	18		23	
4.5 to 5.5			15		19				
t <sub>PHZ</sub> /t <sub>PLZ</sub>	3-state output disable time nOE to nY	Figures 1, 2	V <sub>CC</sub> (V)						ns
			1.2		65				
			2.0		24	32		39	
			2.7		28	24		29	
			3.0 to 3.6		14 <sup>2</sup>	20		24	
4.5 to 5.5			17		21				

**NOTES:**

1. Unless otherwise stated, all typical values are measured at T<sub>amb</sub> = 25°C
2. Typical values are measured at V<sub>CC</sub> = 3.3 V.

# Quad buffer/line driver (3-State)

74LV126

## AC WAVEFORMS

$V_M = 1.5\text{ V}$  at  $V_{CC} \geq 2.7\text{ V}$  and  $\leq 3.6\text{ V}$ ;  
 $V_M = 0.5 \times V_{CC}$  at  $V_{CC} < 2.7\text{ V}$  and  $\geq 4.5\text{ V}$ ;  
 $V_{OL}$  and  $V_{OH}$  are the typical output voltage drop that occur with the output load.  
 $V_X = V_{OL} + 0.3\text{ V}$  at  $V_{CC} \geq 2.7\text{ V}$  and  $\leq 3.6\text{ V}$ ;  
 $V_X = V_{OL} + 0.1 \times V_{CC}$  at  $V_{CC} < 2.7\text{ V}$  and  $\geq 4.5\text{ V}$ .  
 $V_Y = V_{OH} - 0.3\text{ V}$  at  $V_{CC} \geq 2.7\text{ V}$  and  $\leq 3.6\text{ V}$ ;  
 $V_Y = V_{OH} - 0.1 \times V_{CC}$  at  $V_{CC} < 2.7\text{ V}$  and  $\geq 4.5\text{ V}$ .

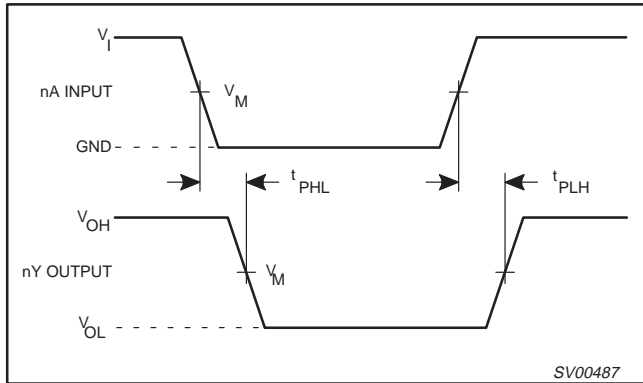

Figure 1. Input (nA, nB) to output (nY) propagation delays

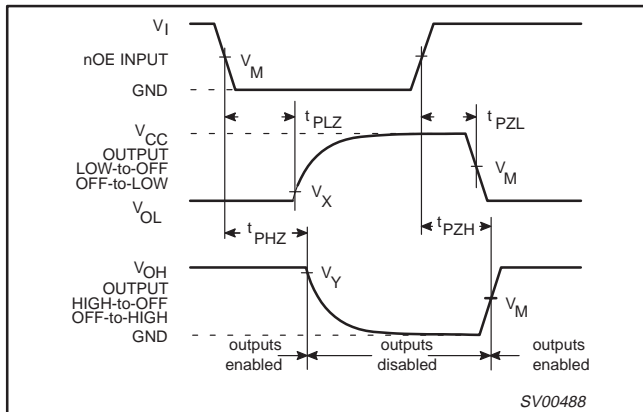

Figure 2. 3-state enable and disable times.

## TEST CIRCUIT

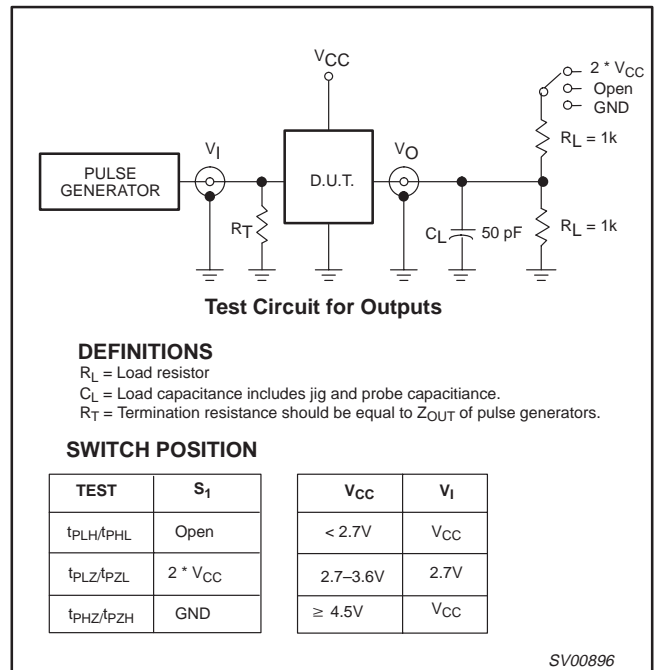

Figure 3. Load circuitry for switching times.

# Quad buffer/line driver (3-State)

# 74LV126

**DIP14: plastic dual in-line package; 14 leads (300 mil)**

**SOT27-1**

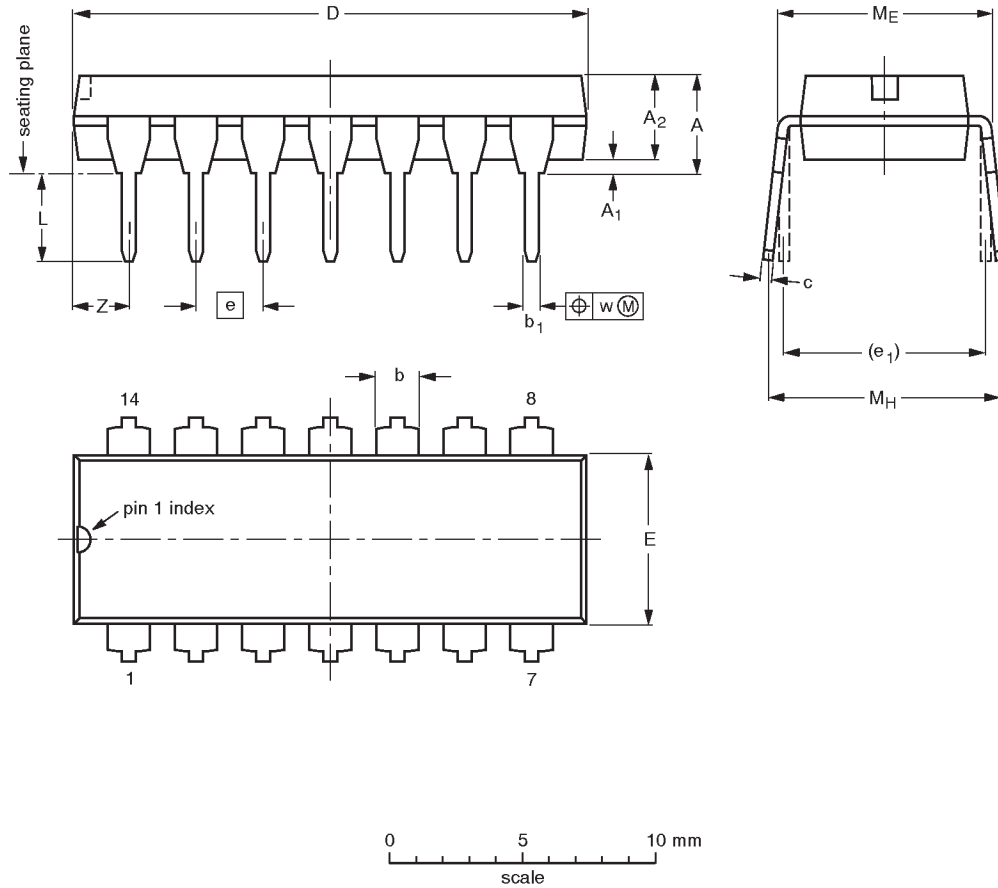

**DIMENSIONS (inch dimensions are derived from the original mm dimensions)**

UNIT	A max.	A <sub>1</sub> min.	A <sub>2</sub> max.	b	b <sub>1</sub>	c	D <sup>(1)</sup>	E <sup>(1)</sup>	e	e <sub>1</sub>	L	M <sub>E</sub>	M <sub>H</sub>	w	Z <sup>(1)</sup> max.
mm	4.2	0.51	3.2	1.73 1.13	0.53 0.38	0.36 0.23	19.50 18.55	6.48 6.20	2.54	7.62	3.60 3.05	8.25 7.80	10.0 8.3	0.254	2.2
inches	0.17	0.020	0.13	0.068 0.044	0.021 0.015	0.014 0.009	0.77 0.73	0.26 0.24	0.10	0.30	0.14 0.12	0.32 0.31	0.39 0.33	0.01	0.087

**Note**

1. Plastic or metal protrusions of 0.25 mm maximum per side are not included.

OUTLINE VERSION	REFERENCES			EUROPEAN PROJECTION	ISSUE DATE
	IEC	JEDEC	EIAJ		
SOT27-1	050G04	MO-001AA			92-11-17 95-03-11

# Quad buffer/line driver (3-State)

# 74LV126

**SO14: plastic small outline package; 14 leads; body width 3.9 mm**

**SOT108-1**

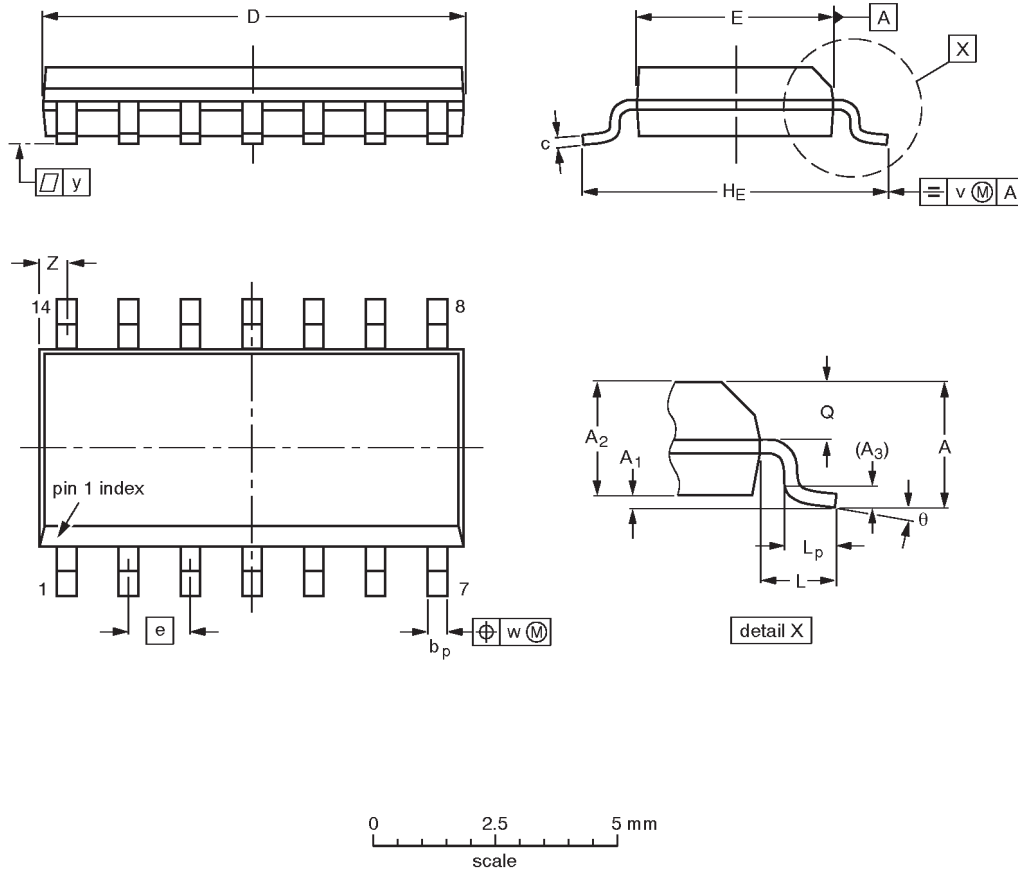

**DIMENSIONS (inch dimensions are derived from the original mm dimensions)**

UNIT	A max.	A <sub>1</sub>	A <sub>2</sub>	A <sub>3</sub>	b <sub>p</sub>	c	D <sup>(1)</sup>	E <sup>(1)</sup>	e	H <sub>E</sub>	L	L <sub>p</sub>	Q	v	w	y	Z <sup>(1)</sup>	θ
mm	1.75	0.25 0.10	1.45 1.25	0.25	0.49 0.36	0.25 0.19	8.75 8.55	4.0 3.8	1.27	6.2 5.8	1.05	1.0 0.4	0.7 0.6	0.25	0.25	0.1	0.7 0.3	8° 0°
inches	0.069	0.0098 0.0039	0.057 0.049	0.01	0.019 0.014	0.0098 0.0075	0.35 0.34	0.16 0.15	0.050	0.24 0.23	0.041	0.039 0.016	0.028 0.024	0.01	0.01	0.004	0.028 0.012	

**Note**

1. Plastic or metal protrusions of 0.15 mm maximum per side are not included.

OUTLINE VERSION	REFERENCES				EUROPEAN PROJECTION	ISSUE DATE
	IEC	JEDEC	EIAJ			
SOT108-1	076E06S	MS-012AB				91-08-13 95-01-23

# Quad buffer/line driver (3-State)

# 74LV126

**SSOP14: plastic shrink small outline package; 14 leads; body width 5.3 mm**

**SOT337-1**

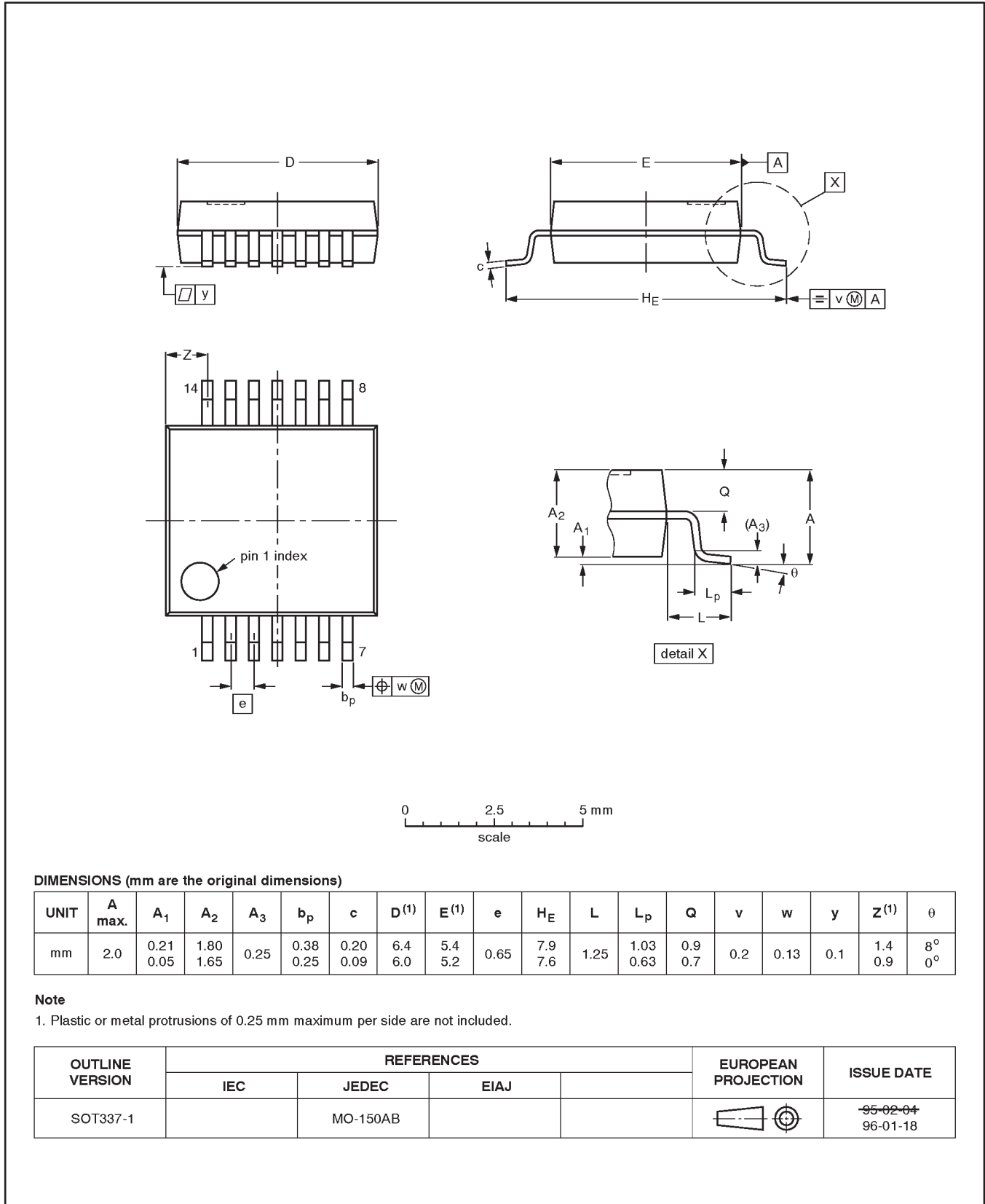

**DIMENSIONS (mm are the original dimensions)**

UNIT	A max.	A <sub>1</sub>	A <sub>2</sub>	A <sub>3</sub>	b <sub>p</sub>	c	D <sup>(1)</sup>	E <sup>(1)</sup>	e	H <sub>E</sub>	L	L <sub>p</sub>	Q	v	w	y	Z <sup>(1)</sup>	θ
mm	2.0	0.21 0.05	1.80 1.65	0.25	0.38 0.25	0.20 0.09	6.4 6.0	5.4 5.2	0.65	7.9 7.6	1.25	1.03 0.63	0.9 0.7	0.2	0.13	0.1	1.4 0.9	8° 0°

**Note**

1. Plastic or metal protrusions of 0.25 mm maximum per side are not included.

OUTLINE VERSION	REFERENCES				EUROPEAN PROJECTION	ISSUE DATE
	IEC	JEDEC	EIAJ			
SOT337-1		MO-150AB				<del>95-02-04</del> 96-01-18

# Quad buffer/line driver (3-State)

# 74LV126

**TSSOP14:** plastic thin shrink small outline package; 14 leads; body width 4.4 mm

**SOT402-1**

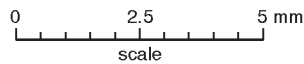
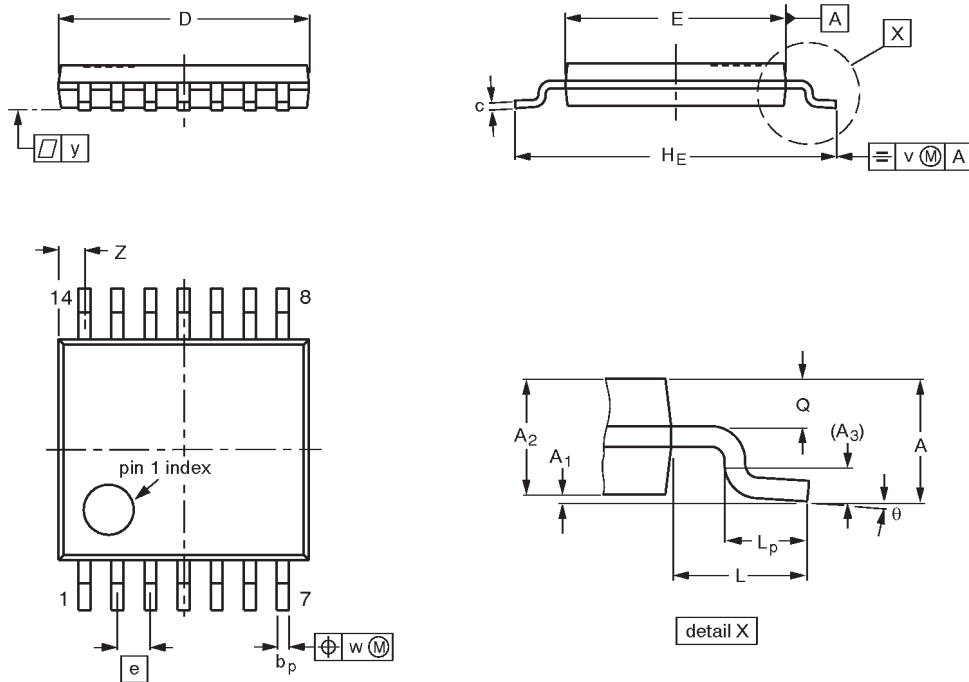

**DIMENSIONS (mm are the original dimensions)**

UNIT	A max.	A <sub>1</sub>	A <sub>2</sub>	A <sub>3</sub>	b <sub>p</sub>	c	D <sup>(1)</sup>	E <sup>(2)</sup>	e	H <sub>E</sub>	L	L <sub>p</sub>	Q	v	w	y	z <sup>(1)</sup>	θ
mm	1.10	0.15 0.05	0.95 0.80	0.25	0.30 0.19	0.2 0.1	5.1 4.9	4.5 4.3	0.65	6.6 6.2	1.0	0.75 0.50	0.4 0.3	0.2	0.13	0.1	0.72 0.38	8° 0°

**Notes**

1. Plastic or metal protrusions of 0.15 mm maximum per side are not included.
2. Plastic interlead protrusions of 0.25 mm maximum per side are not included.

OUTLINE VERSION	REFERENCES				EUROPEAN PROJECTION	ISSUE DATE
	IEC	JEDEC	EIAJ			
SOT402-1		MO-153				-94-07-12- 95-04-04

---

Quad buffer/line driver (3-State)

74LV126

---

**NOTES**

## Quad buffer/line driver (3-State)

74LV126

## DEFINITIONS

Data Sheet Identification	Product Status	Definition
<i>Objective Specification</i>	<b>Formative or in Design</b>	This data sheet contains the design target or goal specifications for product development. Specifications may change in any manner without notice.
<i>Preliminary Specification</i>	<b>Preproduction Product</b>	This data sheet contains preliminary data, and supplementary data will be published at a later date. Philips Semiconductors reserves the right to make changes at any time without notice in order to improve design and supply the best possible product.
<i>Product Specification</i>	<b>Full Production</b>	This data sheet contains Final Specifications. Philips Semiconductors reserves the right to make changes at any time without notice, in order to improve design and supply the best possible product.

Philips Semiconductors and Philips Electronics North America Corporation reserve the right to make changes, without notice, in the products, including circuits, standard cells, and/or software, described or contained herein in order to improve design and/or performance. Philips Semiconductors assumes no responsibility or liability for the use of any of these products, conveys no license or title under any patent, copyright, or mask work right to these products, and makes no representations or warranties that these products are free from patent, copyright, or mask work right infringement, unless otherwise specified. Applications that are described herein for any of these products are for illustrative purposes only. Philips Semiconductors makes no representation or warranty that such applications will be suitable for the specified use without further testing or modification.

## LIFE SUPPORT APPLICATIONS

Philips Semiconductors and Philips Electronics North America Corporation Products are not designed for use in life support appliances, devices, or systems where malfunction of a Philips Semiconductors and Philips Electronics North America Corporation Product can reasonably be expected to result in a personal injury. Philips Semiconductors and Philips Electronics North America Corporation customers using or selling Philips Semiconductors and Philips Electronics North America Corporation Products for use in such applications do so at their own risk and agree to fully indemnify Philips Semiconductors and Philips Electronics North America Corporation for any damages resulting from such improper use or sale.

**Philips Semiconductors**  
**811 East Arques Avenue**  
**P.O. Box 3409**  
**Sunnyvale, California 94088-3409**  
**Telephone 800-234-7381**

© Copyright Philips Electronics North America Corporation 1998  
 All rights reserved. Printed in U.S.A.

print code

Date of release: 05-96

Document order number:

9397-750-04421

*Let's make things better.*



LittleDiode supplies new, hard to find or obsolete electronic components and semiconductors all over the world.

With over two million different components listed you are sure to find the part you need.

Feel free to visit us today at our online store:

[LittleDiode.com](http://LittleDiode.com)

Looking forward to providing you with the best possible service.