

74LV165

8-bit parallel-in/serial-out shift register

Rev. 6 — 19 February 2014

Product data sheet

1. General description

The 74LV165 is an 8-bit parallel-load or serial-in shift register with complementary serial outputs (Q7 and $\overline{Q7}$) available from the last stage. When the parallel-load input (\overline{PL}) is LOW, parallel data from the inputs D0 to D7 are loaded into the register asynchronously. When input \overline{PL} is HIGH, data enters the register serially at the input DS. It shifts one place to the right (Q0 → Q1 → Q2, etc.) with each positive-going clock transition. This feature allows parallel-to-serial converter expansion by tying the output Q7 to the input DS of the succeeding stage.

The clock input is a gate-OR structure which allows one input to be used as an active LOW clock enable input (\overline{CE}) input. The pin assignment for the inputs CP and \overline{CE} is arbitrary and can be reversed for layout convenience. The LOW-to-HIGH transition of the input \overline{CE} should only take place while CP HIGH for predictable operation. Either the CP or the \overline{CE} should be HIGH before the LOW-to-HIGH transition of \overline{PL} to prevent shifting the data when PL is activated.

2. Features and benefits

- Wide supply voltage range from 1.0 V to 5.5 V
- Synchronous parallel-to-serial applications
- Optimized for low voltage applications: 1.0 V to 3.6 V
- Synchronous serial input for easy expansion
- Latch-up performance exceeds 250 mA
- 5.5 V tolerant inputs/outputs
- Direct interface with TTL levels (2.7 V to 3.6 V)
- Power-down mode
- Complies with JEDEC standards:
 - ◆ JESD8-5 (2.3 V to 2.7 V)
 - ◆ JESD8B/JESD36 (2.7 V to 3.6 V)
 - ◆ JESD8-1A (4.5 V to 5.5 V)
- ESD protection:
 - ◆ HBM JESD22-A114-A exceeds 2000 V
 - ◆ MM JESD22-A115-A exceeds 200 V
- Specified from -40 °C to +85 °C and from -40 °C to +125 °C



3. Ordering information

Table 1. Ordering information

Type number	Package			Version
	Temperature range	Name	Description	
74LV165N	-40 °C to +125 °C	DIP16	plastic dual in-line package; 16 leads (300 mil)	SOT38-4
74LV165D	-40 °C to +125 °C	SO16	plastic small outline package; 16 leads; body width 3.9 mm	SOT109-1
74LV165DB	-40 °C to +125 °C	SSOP16	plastic shrink small outline package; 16 leads; body width 5.3 mm	SOT338-1
74LV165PW	-40 °C to +125 °C	TSSOP16	plastic thin shrink small outline package; 16 leads; body width 4.4 mm	SOT403-1

4. Functional diagram

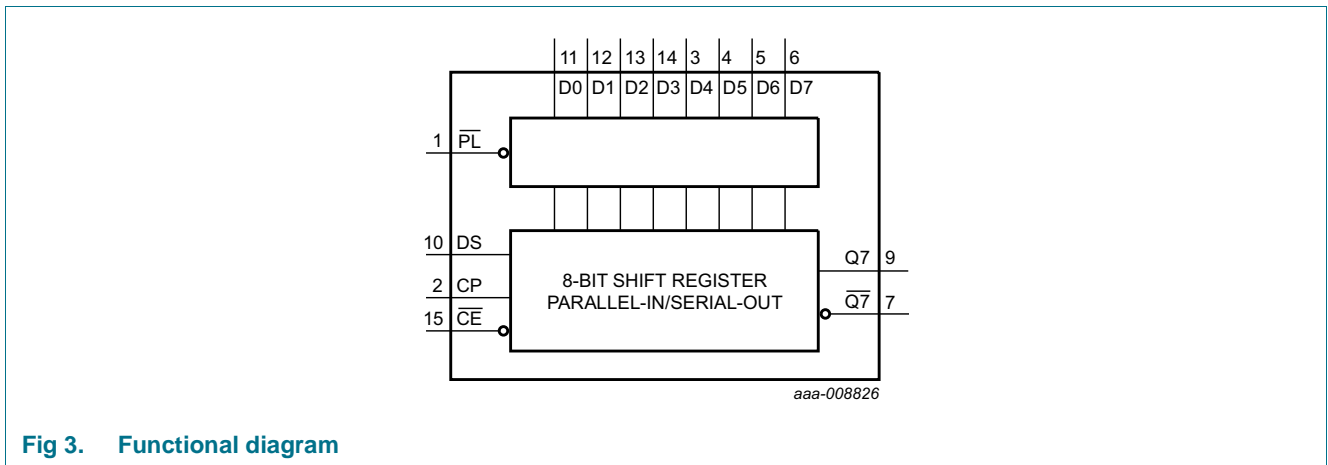
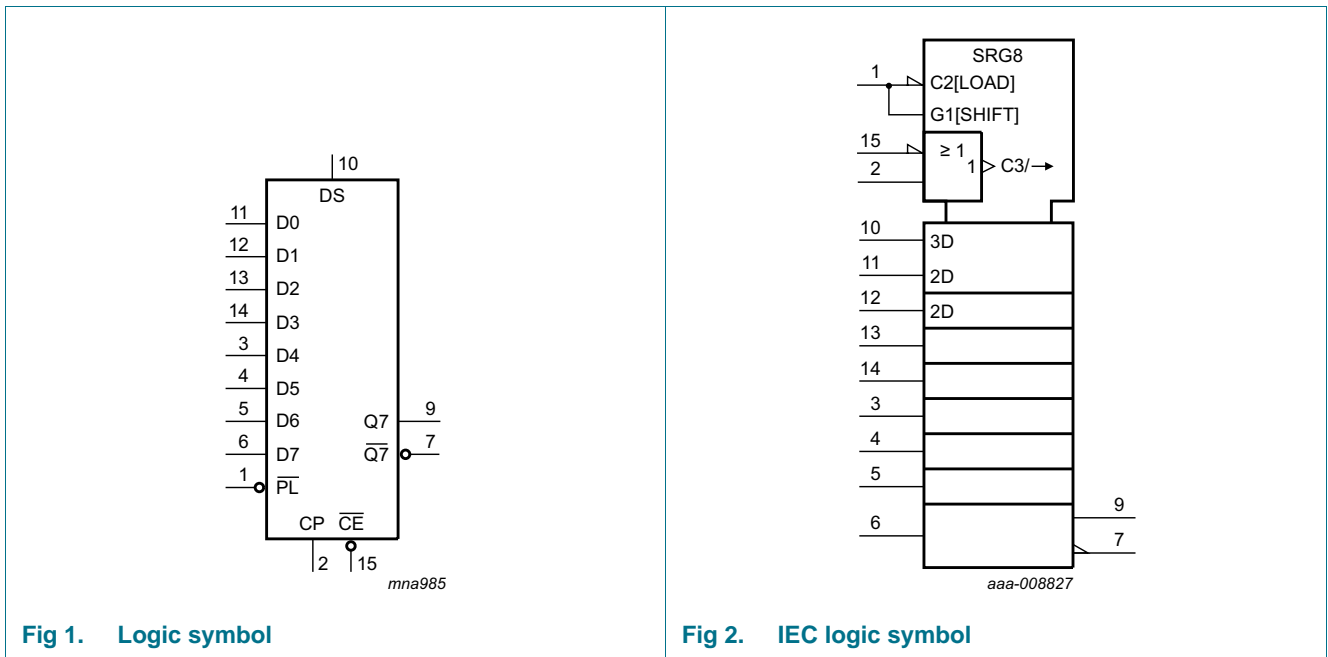

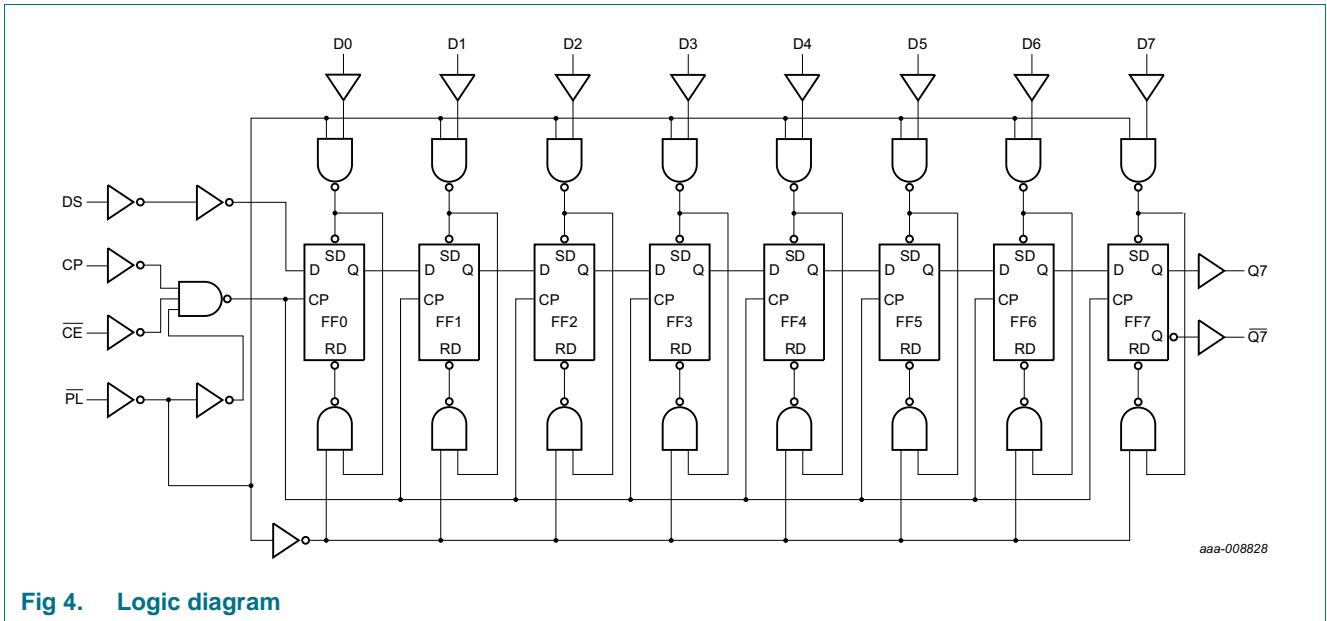

Fig 4. Logic diagram

5. Pinning information

5.1 Pinning

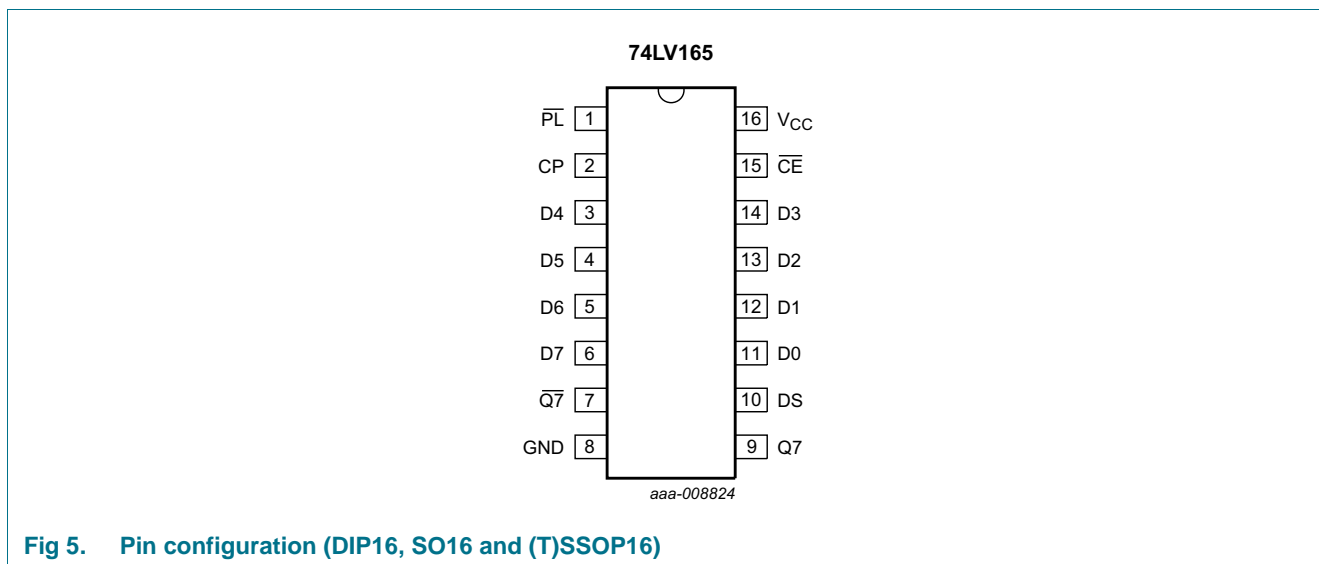

Fig 5. Pin configuration (DIP16, SO16 and (T)SSOP16)

5.2 Pin description

Table 2. Pin description

Symbol	Pin	Description
\overline{PL}	1	parallel enable input (active LOW)
CP	2	clock input (LOW-to-HIGH edge-triggered)
$\overline{Q7}$	7	complementary serial output from the last stage
GND	8	ground (0 V)
Q7	9	serial output from the last stage
DS	10	serial data input
D0 to D7	11, 12, 13, 14, 3, 4, 5, 6	parallel data inputs
\overline{CE}	15	clock enable input (active LOW)
V _{CC}	16	positive supply voltage

6. Functional description

Table 3. Function table^[1]

Operating modes	Inputs					Qn registers		Output	
	$\overline{\text{PL}}$	$\overline{\text{CE}}$	CP	DS	D0 to D7	Q0	Q1 to Q6	Q7	$\overline{\text{Q7}}$
parallel load	L	X	X	X	L	L	L to L	L	H
	L	X	X	X	H	H	H to H	H	L
serial shift	H	L	↑	l	X	L	q0 to q5	q6	$\overline{\text{q6}}$
	H	L	↑	h	X	H	q0 to q5	q6	$\overline{\text{q6}}$
hold "do nothing"	H	H	X	X	X	q0	q1 to q6	q7	q7

- [1] H = HIGH voltage level;
 h = HIGH voltage level one set-up time prior to the LOW-to-HIGH clock transition;
 L = LOW voltage level;
 l = LOW voltage level one set-up time prior to the LOW-to-HIGH clock transition;
 q = state of the referenced output one set-up time prior to the LOW-to-HIGH clock transition;
 X = don't care;
 ↑ = LOW-to-HIGH clock transition.

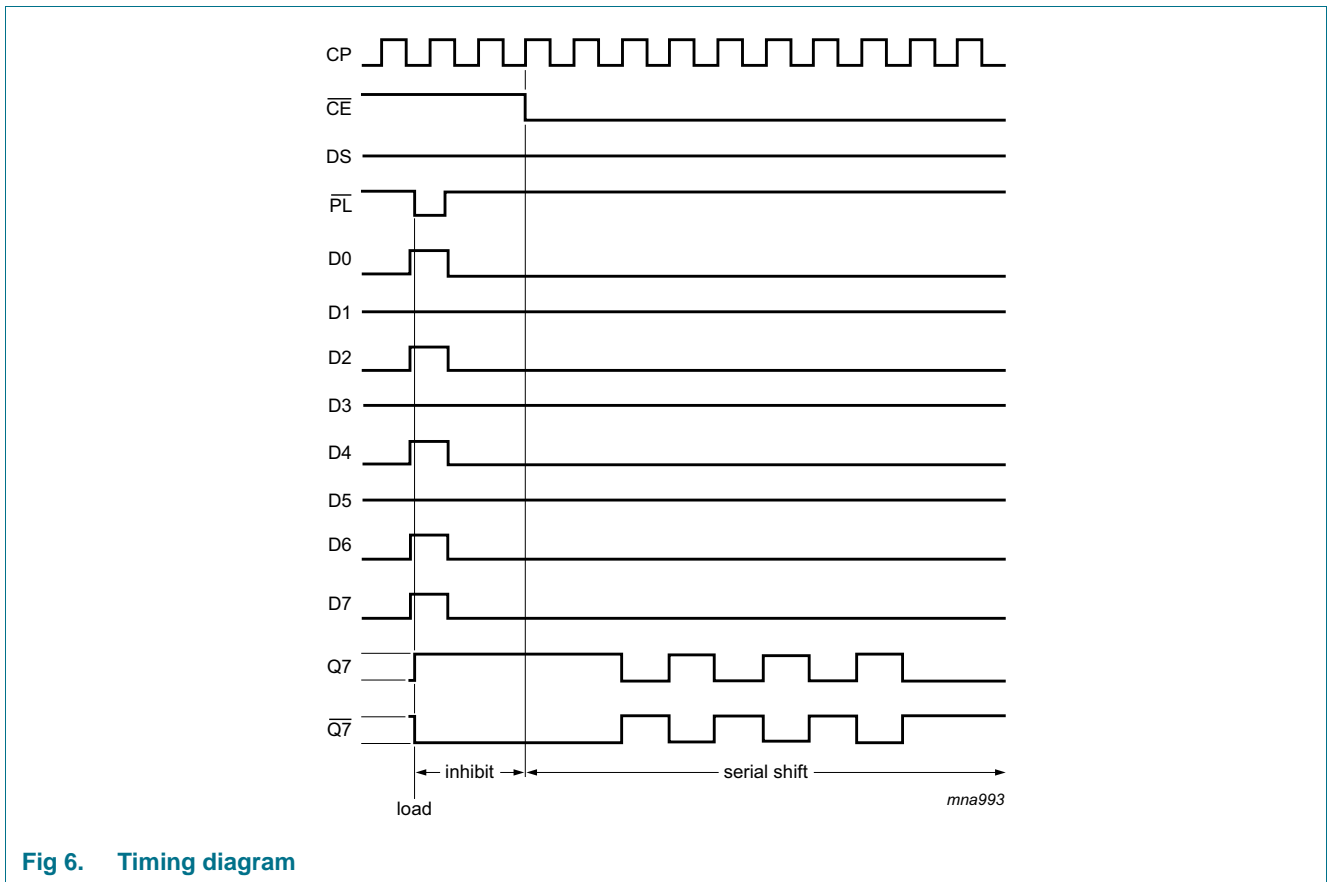

Fig 6. Timing diagram

7. Limiting values

Table 4. Limiting values

In accordance with the Absolute Maximum Rating System (IEC 60134). Voltages are referenced to GND (ground = 0 V)^[1]

Symbol	Parameter	Conditions	Min	Max	Unit
V _{CC}	supply voltage		-0.5	+7	V
I _{IK}	input clamping current	V _I < -0.5 V or V _I > V _{CC} + 0.5 V	-	20	mA
V _I	input voltage		-0.5	+7	V
I _{OK}	output clamping current	V _O > V _{CC} or V _O < 0	-	±50	mA
I _O	output current	-0.5 V < V _O < V _{CC} + 0.5 V	-	±25	mA
I _{CC}	supply current		-	+50	mA
I _{GND}	ground current		-50	-	mA
T _{stg}	storage temperature		-65	+150	°C
P _{tot}	total power dissipation	T _{amb} = -40 °C to +125 °C			
		DIP16 package	^[2] -	750	mW
		SO16 package	^[3] -	500	mW
		(T)SSOP16 package	^[4] -	400	mW

[1] The input and output voltage ratings may be exceeded if the input and output current ratings are observed.

[2] P_{tot} derates linearly with 12 mW/K above 70 °C.

[3] P_{tot} derates linearly with 8 mW/K above 70 °C.

[4] P_{tot} derates linearly with 5.5 mW/K above 60 °C.

8. Recommended operating conditions

Table 5. Recommended operating conditions

Voltages are referenced to GND (ground = 0 V)

Symbol	Parameter	Conditions	Min	Typ	Max	Unit
V _{CC}	supply voltage		1.0	3.3	5.5	V
V _I	input voltage		0	-	V _{CC}	V
V _O	output voltage		0	-	V _{CC}	V
T _{amb}	ambient temperature		-40	-	+85	°C
Δt/ΔV	input transition rise and fall rate	V _{CC} = 1.0 V to 2.0 V	0	-	500	ns/V
		V _{CC} = 2.0 V to 2.7 V	0	-	200	ns/V
		V _{CC} = 2.7 V to 3.6 V	0	-	100	ns/V
		V _{CC} = 3.6 V to 5.5 V	0	-	50	ns/V

9. Static characteristics

Table 6. Static characteristics

At recommended operating conditions; voltages are referenced to GND (ground = 0 V).

Symbol	Parameter	Conditions	-40 °C to +85 °C			-40 °C to +125 °C		Unit	
			Min	Typ ^[1]	Max	Min	Max		
V _{IH}	HIGH-level input voltage	V _{CC} = 1.2 V	0.9	-	-	0.9	-	V	
		V _{CC} = 2.3 V to 2.7 V	1.4	-	-	1.4	-	V	
		V _{CC} = 2.7 V to 3.6 V	2.0	-	-	2.0	-	V	
		V _{CC} = 4.5 V to 5.5 V	0.7V _{CC}	-	-	0.7V _{CC}	-	V	
V _{IL}	LOW-level input voltage	V _{CC} = 1.2 V	-	-	0.3	-	0.3	V	
		V _{CC} = 2.3 V to 2.7 V	-	-	0.6	-	0.6	V	
		V _{CC} = 2.7 V to 3.6 V	-	-	0.8	-	0.8	V	
		V _{CC} = 4.5 V to 5.5 V	-	-	0.3V _{CC}	-	0.3V _{CC}		
V _{OH}	HIGH-level output voltage	V _I = V _{IH} or V _{IL} ; I _O = -100 μA							
		V _{CC} = 1.2 V	-	1.2	-	-	-		
		V _{CC} = 2.0 V	1.8	2.0	-	1.8	-	V	
		V _{CC} = 2.7 V	2.5	2.7	-	2.5	-	V	
		V _{CC} = 3.0 V	2.8	3.0	-	2.8	-	V	
		V _{CC} = 4.5 V	4.3	4.5	-	4.3	-	V	
		standard outputs: V _I = V _{IH} or V _{IL}							
		V _{CC} = 3.0 V; I _O = -6 mA	2.40	2.82	-	2.20	-	V	
V _{CC} = 4.5 V; I _O = -12 mA	3.60	4.20	-	3.50	-	V			
V _{OL}	LOW-level output voltage	V _I = V _{IH} or V _{IL} ; I _O = 100 μA							
		V _{CC} = 1.2 V	-	0	-	-	-		
		V _{CC} = 2.0 V	-	0	0.2	1.8	0.2	V	
		V _{CC} = 2.7 V	-	0	0.2	2.5	0.2	V	
		V _{CC} = 3.0 V	-	0	0.2	2.8	0.2	V	
		V _{CC} = 4.5 V	-	0	0.2	4.3	0.2	V	
		standard outputs: V _I = V _{IH} or V _{IL}							
		V _{CC} = 3.0 V; I _O = 6 mA	-	0.25	0.40	-	0.50	V	
V _{CC} = 4.5 V; I _O = 12 mA	-	0.35	0.55	-	0.65	V			
I _I	input leakage current	V _I = V _{CC} or GND; V _{CC} = 5.5 V	-	-	±1	-	±1	μA	
I _{CC}	supply current	V _I = V _{CC} or GND; I _O = 0 A; V _{CC} = 5.5 V	-	-	20	-	160	μA	
ΔI _{CC}	additional supply current	V _I = V _{CC} - 0.6 V; V _{CC} = 2.7 V to 3.6 V	-	-	500	-	850	μA	
C _I	input capacitance		-	3.5	-			pF	

[1] Typical values are measured at T_{amb} = 25 °C.

10. Dynamic characteristics

Table 7. Dynamic characteristics

GND (ground = 0 V); for test circuit, see [Figure 12](#)

Symbol	Parameter	Conditions	-40 °C to +85 °C			-40 °C to +125 °C		Unit	
			Min	Typ ^[1]	Max	Min	Max		
t _{pd}	propagation delay	\overline{CE} , CP to Q7, $\overline{Q7}$; see Figure 7 and Figure 8		[2]					
		V _{CC} = 1.2 V	-	115	-	-	-	ns	
		V _{CC} = 2.0 V	-	38	61	-	76	ns	
		V _{CC} = 2.7 V	-	27	43	-	54	ns	
		V _{CC} = 3.0 V to 3.6 V	[3]	22	36	-	45	ns	
		V _{CC} = 3.3 V; C _L = 15 pF		18	-	-	-	ns	
		V _{CC} = 4.5 V to 5.5 V	[4]	15	24	-	30	ns	
		\overline{PL} to Q7, $\overline{Q7}$; see Figure 8							
		V _{CC} = 1.2 V	-	110	-	-	-	ns	
		V _{CC} = 2.0 V	-	35	56	-	70	ns	
		V _{CC} = 2.7 V	-	24	39	-	49	ns	
		V _{CC} = 3.0 V to 3.6 V	[3]	20	33	-	41	ns	
		V _{CC} = 3.3 V; C _L = 15 pF		18	-	-	-	ns	
		V _{CC} = 4.5 V to 5.5 V	[4]	14	22	-	27	ns	
		D7 to Q7, $\overline{Q7}$; C _L = 15 pF; see Figure 9							
		V _{CC} = 1.2 V	-	90	-	-	-	ns	
		V _{CC} = 2.0 V	-	28	45	-	56	ns	
		V _{CC} = 2.7 V	-	20	32	-	40	ns	
V _{CC} = 3.0 V to 3.6 V	[3]	17	27	-	33	ns			
V _{CC} = 3.3 V; C _L = 15 pF		14	-	-	-	ns			
V _{CC} = 4.5 V to 5.5 V	[4]	11	18	-	22	ns			
t _w	pulse width	CP input HIGH to LOW; see Figure 7							
		V _{CC} = 2.0 V	34	10	-	41	-	ns	
		V _{CC} = 2.7 V	25	8	-	30	-	ns	
		V _{CC} = 3.0 V to 3.6 V	[3]	20	7	-	24	-	ns
		V _{CC} = 4.5 V to 5.5 V	[4]	15	5	-	18	-	ns
		\overline{PL} input LOW; see Figure 8							
		V _{CC} = 2.0 V	34	10	-	41	-	ns	
		V _{CC} = 2.7 V	25	8	-	30	-	ns	
		V _{CC} = 3.0 V to 3.6 V	[3]	20	7	-	24	-	ns
		V _{CC} = 4.5 V to 5.5 V	[4]	15	5	-	18	-	ns

Table 7. Dynamic characteristics ...continued
 GND (ground = 0 V); for test circuit, see [Figure 12](#)

Symbol	Parameter	Conditions	-40 °C to +85 °C			-40 °C to +125 °C		Unit		
			Min	Typ ^[1]	Max	Min	Max			
t _{rec}	recovery time	\overline{PL} to CP, \overline{CE} ; see Figure 8								
		V _{CC} = 1.2 V	-	40	-	-	-	ns		
		V _{CC} = 2.0 V	24	15	-	30	-	ns		
		V _{CC} = 2.7 V	18	11	-	23	-	ns		
		V _{CC} = 3.0 V to 3.6 V [3]	17	10	-	21	-	ns		
		V _{CC} = 4.5 V to 5.5 V [4]	12	7	-	15	-	ns		
t _{su}	set-up time	DS to CP, \overline{CE} ; see Figure 10								
		V _{CC} = 1.2 V	-	-8	-	-	-	ns		
		V _{CC} = 2.0 V	22	-2	-	26	-	ns		
		V _{CC} = 2.7 V	16	-1	-	19	-	ns		
		V _{CC} = 3.0 V to 3.6 V [3]	13	-1	-	15	-	ns		
		V _{CC} = 4.5 V to 5.5 V [4]	9	0	-	10	-	ns		
		\overline{CE} to CP, CP to \overline{CE} ; see Figure 10								
		V _{CC} = 1.2 V	-	20	-	-	-	ns		
		V _{CC} = 2.0 V	22	7	-	26	-	ns		
		V _{CC} = 2.7 V	16	5	-	19	-	ns		
		V _{CC} = 3.0 V to 3.6 V [3]	13	4	-	15	-	ns		
		V _{CC} = 4.5 V to 5.5 V [4]	9	3	-	10	-	ns		
		Dn to \overline{PL} ; see Figure 11								
		V _{CC} = 1.2 V	-	25	-	-	-	ns		
		V _{CC} = 2.0 V	22	8	-	26	-	ns		
		V _{CC} = 2.7 V	16	6	-	19	-	ns		
		V _{CC} = 3.0 V to 3.6 V [3]	13	5	-	15	-	ns		
		V _{CC} = 4.5 V to 5.5 V [4]	9	4	-	10	-	ns		
		t _h	hold time	DS to CP, \overline{CE} ; Dn to \overline{PL} ; see Figure 10 and Figure 11						
				V _{CC} = 1.2 V	-	20	-	-	-	ns
				V _{CC} = 2.0 V	22	7	-	26	-	ns
V _{CC} = 2.7 V	16			5	-	19	-	ns		
V _{CC} = 3.0 V to 3.6 V [3]	13			4	-	15	-	ns		
V _{CC} = 4.5 V to 5.5 V [4]	9			3	-	10	-	ns		
\overline{CE} to CP, CP to \overline{CE} ; see Figure 10										
V _{CC} = 1.2 V	-			-30	-	-	-	ns		
V _{CC} = 2.0 V	5			-8	-	5	-	ns		
V _{CC} = 2.7 V	5			-6	-	5	-	ns		
V _{CC} = 3.0 V to 3.6 V [3]	5			-5	-	5	-	ns		
V _{CC} = 4.5 V to 5.5 V [4]	5			-4	-	5	-	ns		

Table 7. Dynamic characteristics ...continued
 GND (ground = 0 V); for test circuit, see [Figure 12](#)

Symbol	Parameter	Conditions	-40 °C to +85 °C			-40 °C to +125 °C		Unit
			Min	Typ ^[1]	Max	Min	Max	
f _{max}	maximum frequency	see Figure 7						
		V _{CC} = 2.0 V	14	40	-	12	-	MHz
		V _{CC} = 2.7 V	19	60	-	16	-	MHz
		V _{CC} = 3.0 V to 3.6 V ^[3]	24	65	-	20	-	MHz
		V _{CC} = 3.3 V; C _L = 15 pF	-	78	-	-	-	MHz
		V _{CC} = 4.5 V to 5.5 V ^[4]	36	75	-	30	-	MHz
C _{PD}	power dissipation capacitance	V _I = GND to V _{CC} ; V _{CC} = 3.3 V ^[5]	-	35	-			pF

- [1] Typical values are measured at T_{amb} = 25 °C.
- [2] t_{pd} is the same as t_{PHL} and t_{PLH}.
- [3] Typical values are measured at V_{CC} = 3.3 V.
- [4] Typical values are measured at V_{CC} = 5.0 V.
- [5] C_{PD} is used to determine the dynamic power dissipation P_D = C_{PD} × V_{CC}² × f_i + Σ (C_L × V_{CC}² × f_o) (P_D in μW), where:
 f_i = input frequency in MHz;
 f_o = output frequency in MHz;
 Σ (C_L × V_{CC}² × f_o) = sum of outputs;
 C_L = output load capacitance in pF;
 V_{CC} = supply voltage in V.

11. Waveforms

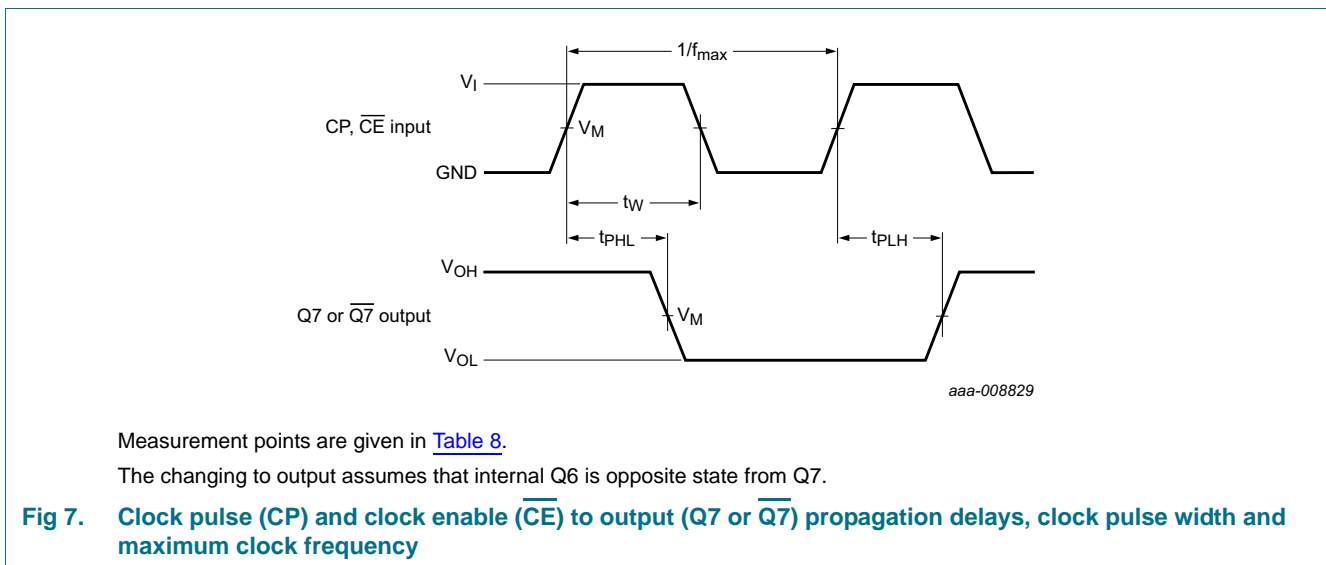

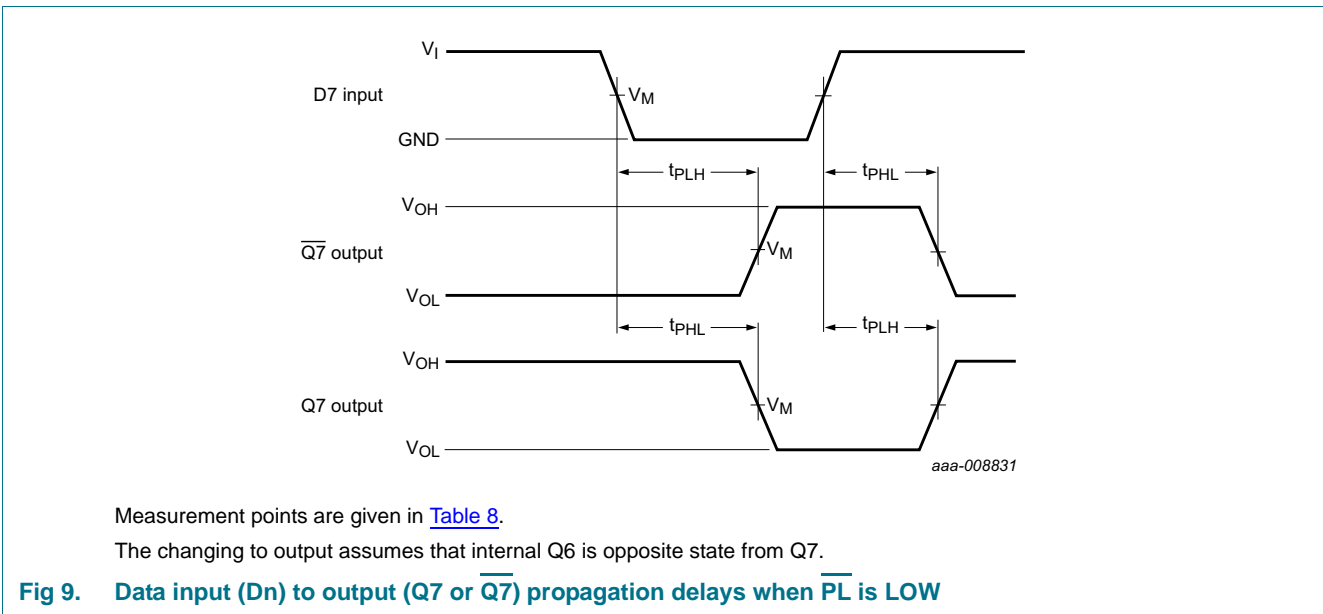
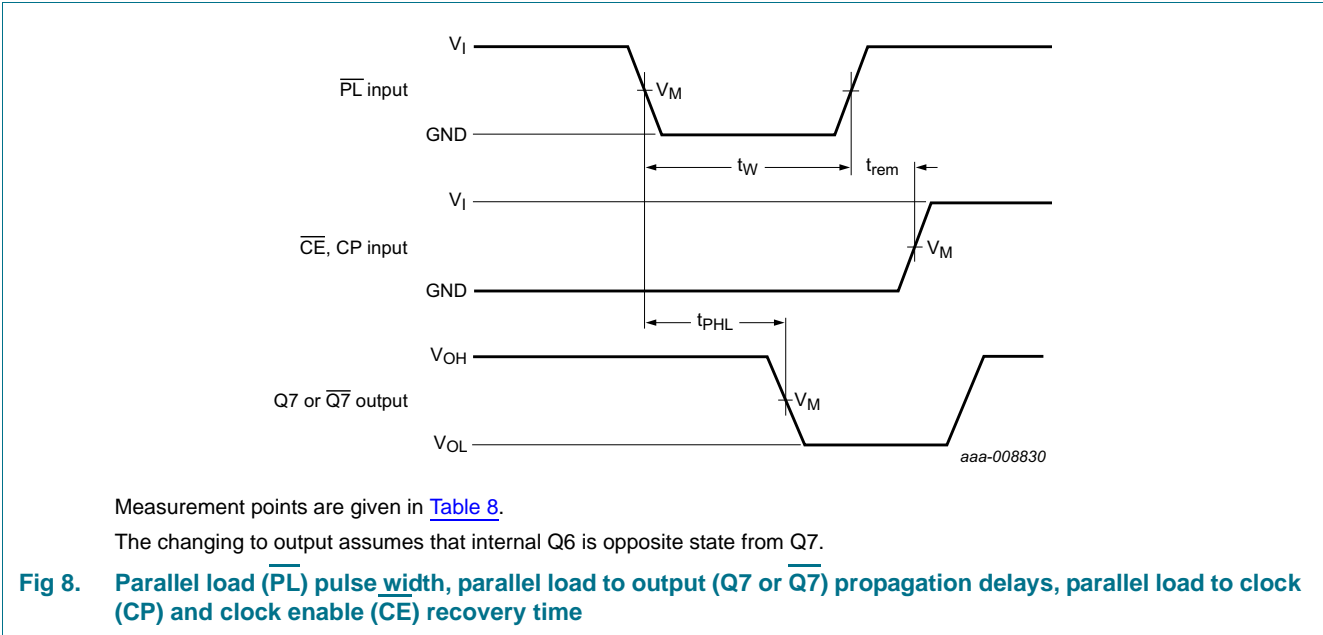

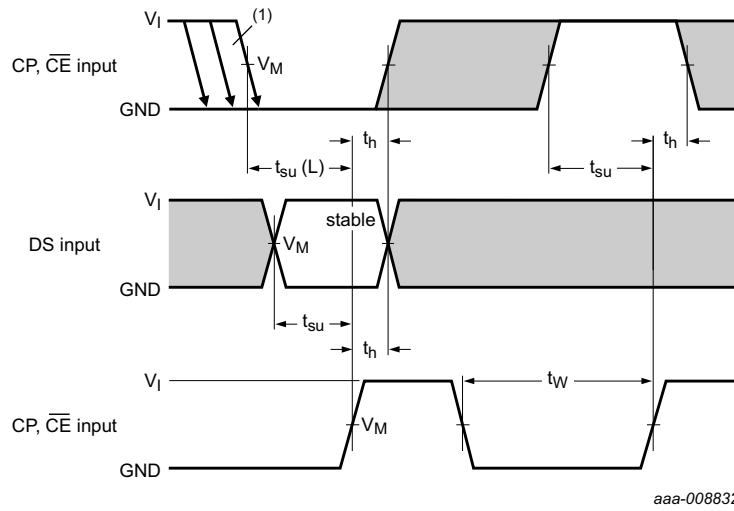

Measurement points are given in [Table 8](#).

- (1) CE may change only from HIGH-to-LOW while CP is LOW. The shaded areas indicate when the input is permitted to change for predictable output performance.

Fig 10. Set-up and hold times

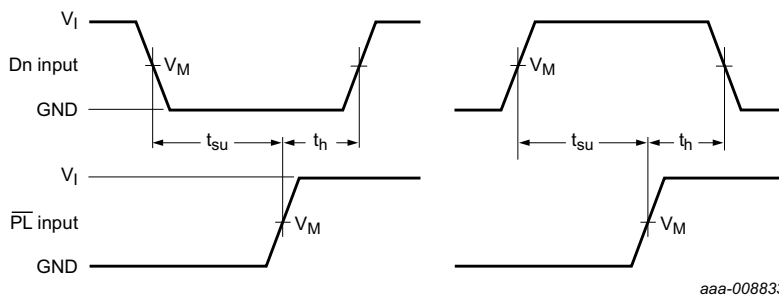

Measurement points are given in [Table 8](#).

Fig 11. Set-up and hold times from the data inputs (Dn) to the parallel load input (PL)

Table 8. Measurement points

Supply voltage	Input	Output
V_{CC}	V_M	V_M
< 2.7 V	$0.5V_{CC}$	$0.5V_{CC}$
2.7 V to 3.6 V	1.5 V	1.5 V
≥ 4.5 V	$0.5V_{CC}$	$0.5V_{CC}$

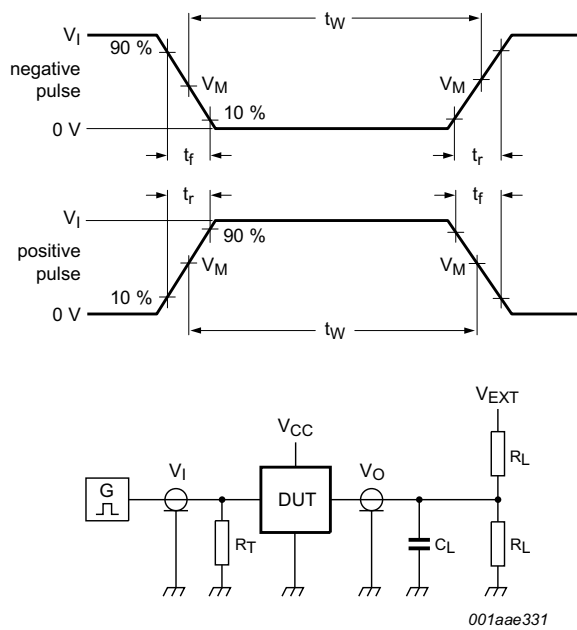

Test data is given in [Table 9](#).

Definitions for test circuit:

R_L = Load resistance.

C_L = Load capacitance including jig and probe capacitance.

R_T = Termination resistance should be equal to output impedance Z_o of the pulse generator.

V_{EXT} = External voltage for measuring switching times.

Fig 12. Test circuit for measuring switching times

Table 9. Test data

Supply voltage	Input		Load		V_{EXT}
	V_I	t_r, t_f	C_L	R_L	t_{PHL}, t_{PLH}
< 2.7 V	V_{CC}	2.5 ns	50 pF	1 k Ω	open
2.7 V to 3.6 V	2.7 V	2.5 ns	50 pF, 15 pF	1 k Ω	open
≥ 4.5 V	V_{CC}	2.5 ns	50 pF	1 k Ω	open

12. Package outline

DIP16: plastic dual in-line package; 16 leads (300 mil)

SOT38-4

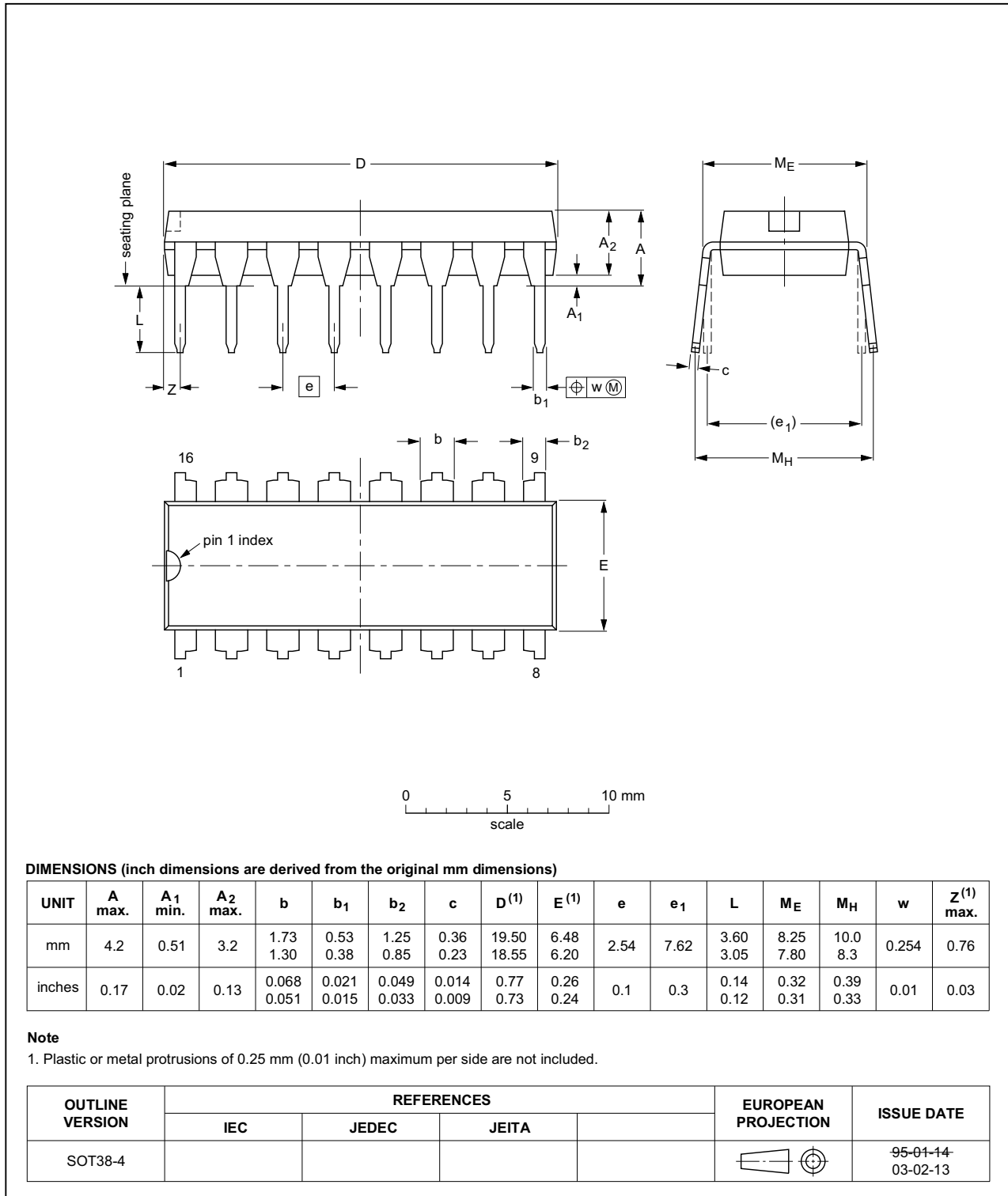

Fig 13. Package outline SOT38-4 (DIP16)

SO16: plastic small outline package; 16 leads; body width 3.9 mm

SOT109-1

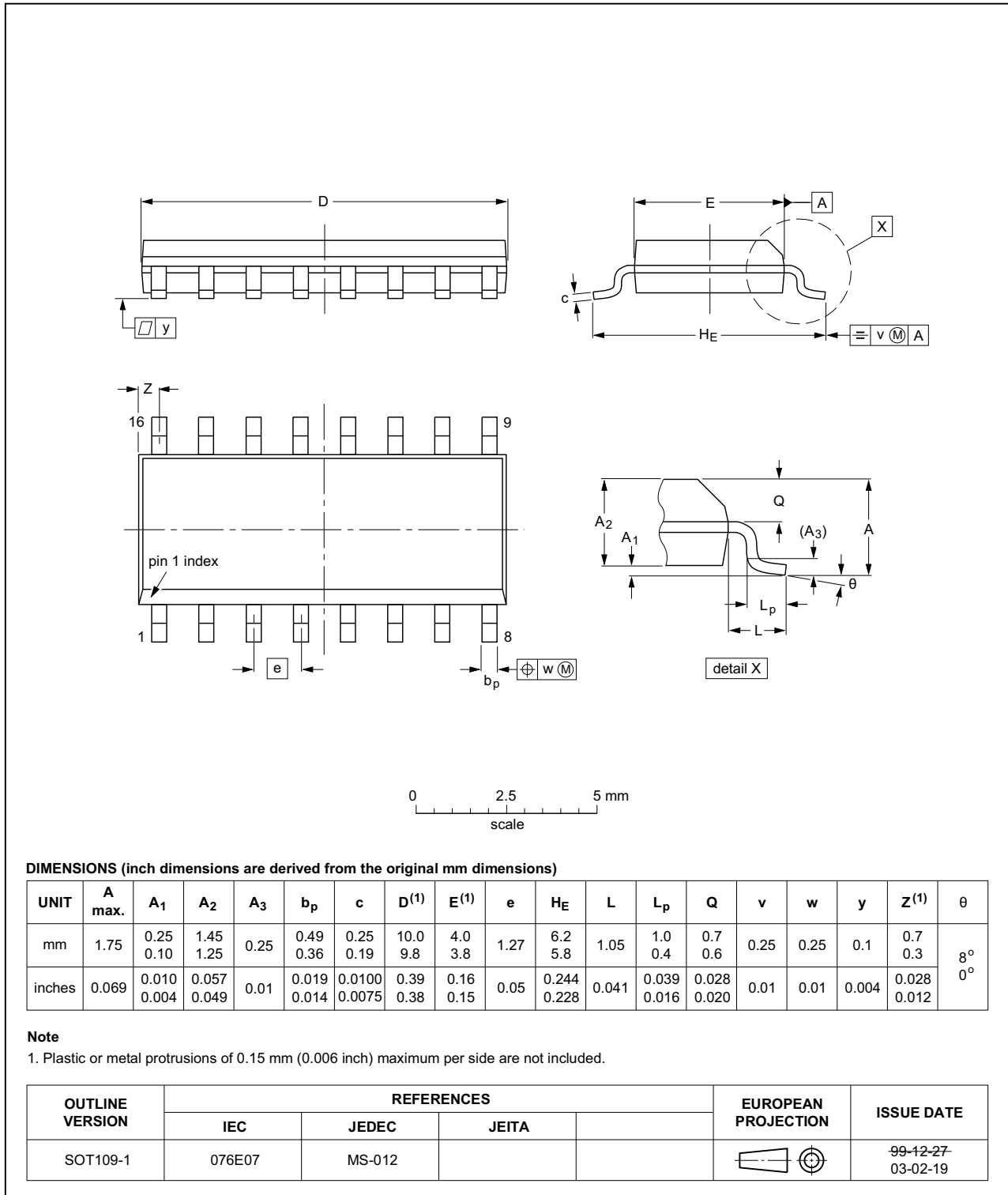

Fig 14. Package outline SOT109-1 (SO16)

SSOP16: plastic shrink small outline package; 16 leads; body width 5.3 mm

SOT338-1

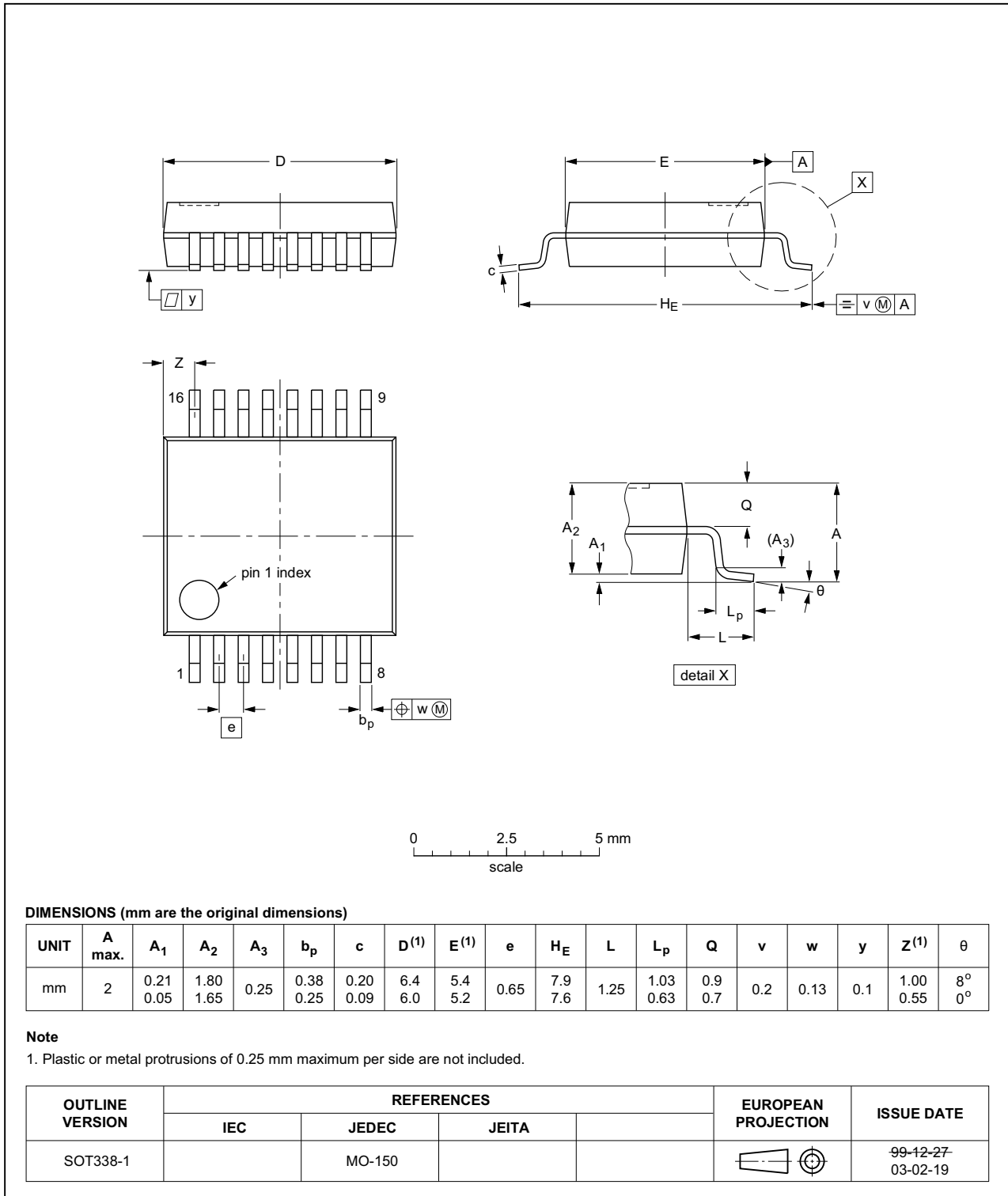

Fig 15. Package outline SOT338-1 (SSOP16)

TSSOP16: plastic thin shrink small outline package; 16 leads; body width 4.4 mm

SOT403-1

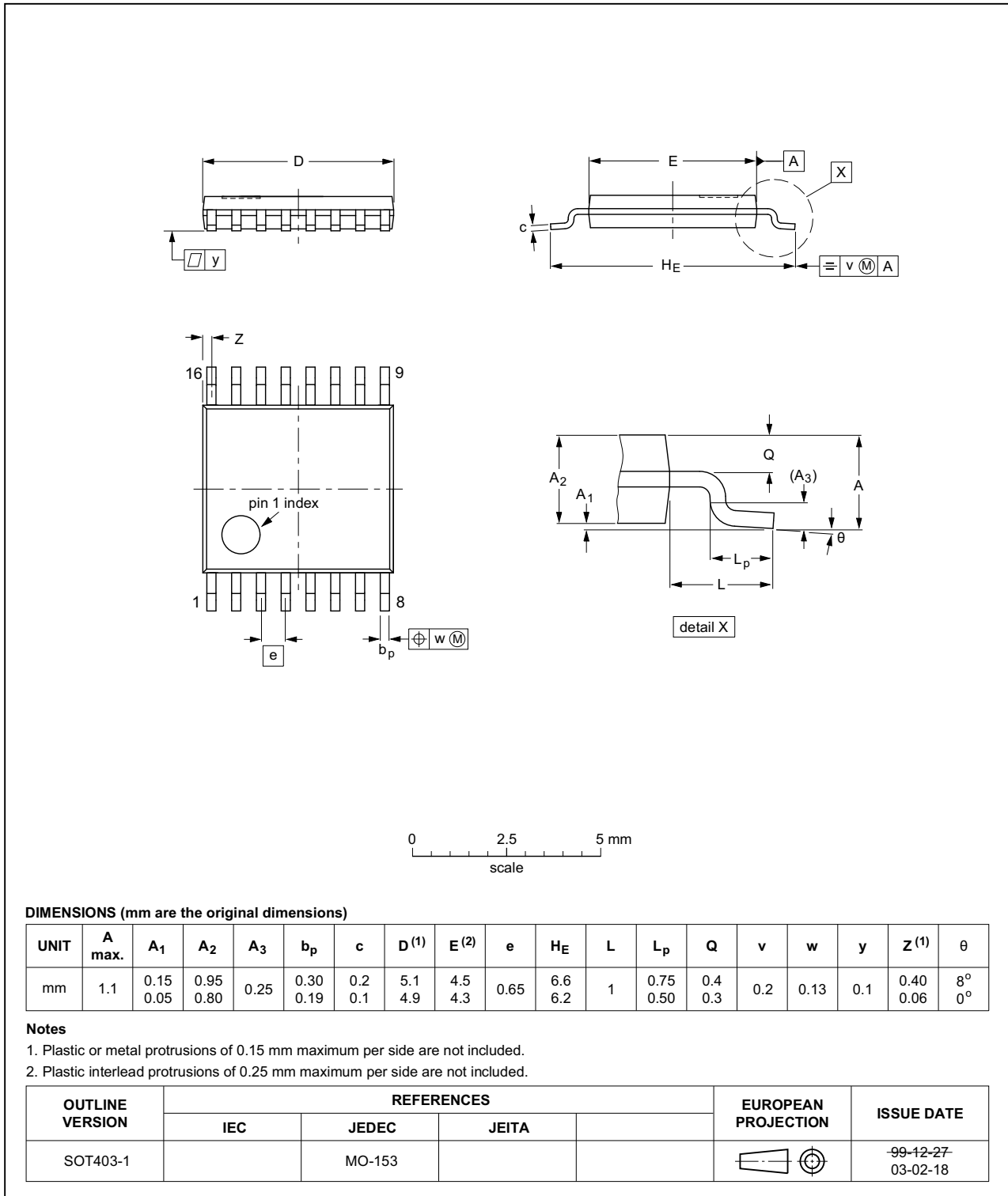

Fig 16. Package outline SOT403-1 (TSSOP16)

13. Abbreviations

Table 10. Abbreviations

Acronym	Description
CMOS	Complementary Metal-Oxide Semiconductor
DUT	Device Under Test
ESD	ElectroStatic Discharge
HBM	Human Body Model
MM	Machine Model
TTL	Transistor-Transistor Logic

14. Revision history

Table 11. Revision history

Document ID	Release date	Data sheet status	Change notice	Supersedes
74LV165 v.6	20140219	Product data sheet	-	74LV165 v.5
Modifications:	<ul style="list-style-type: none"> • Typo corrected in Table 2 "Pin description" 			
74LV165 v.5	20130909	Product data sheet	-	74LV165 v.4
Modifications:	<ul style="list-style-type: none"> • Typo corrected in the header of Table 6 "Static characteristics" 			
74LV165 v.4	20130830	Product data sheet	-	74LV165_CNV_3
Modifications:	<ul style="list-style-type: none"> • The format of this data sheet has been redesigned to comply with the new identity guidelines of NXP Semiconductors. • Legal texts have been adapted to the new company name where appropriate. • Family data added, see Section 9 "Static characteristics" 			
74LV165_CNV_3	December 1998	Product specification	-	-

15. Legal information

15.1 Data sheet status

Document status ^{[1][2]}	Product status ^[3]	Definition
Objective [short] data sheet	Development	This document contains data from the objective specification for product development.
Preliminary [short] data sheet	Qualification	This document contains data from the preliminary specification.
Product [short] data sheet	Production	This document contains the product specification.

[1] Please consult the most recently issued document before initiating or completing a design.

[2] The term 'short data sheet' is explained in section "Definitions".

[3] The product status of device(s) described in this document may have changed since this document was published and may differ in case of multiple devices. The latest product status information is available on the Internet at URL <http://www.nxp.com>.

15.2 Definitions

Draft — The document is a draft version only. The content is still under internal review and subject to formal approval, which may result in modifications or additions. NXP Semiconductors does not give any representations or warranties as to the accuracy or completeness of information included herein and shall have no liability for the consequences of use of such information.

Short data sheet — A short data sheet is an extract from a full data sheet with the same product type number(s) and title. A short data sheet is intended for quick reference only and should not be relied upon to contain detailed and full information. For detailed and full information see the relevant full data sheet, which is available on request via the local NXP Semiconductors sales office. In case of any inconsistency or conflict with the short data sheet, the full data sheet shall prevail.

Product specification — The information and data provided in a Product data sheet shall define the specification of the product as agreed between NXP Semiconductors and its customer, unless NXP Semiconductors and customer have explicitly agreed otherwise in writing. In no event however, shall an agreement be valid in which the NXP Semiconductors product is deemed to offer functions and qualities beyond those described in the Product data sheet.

15.3 Disclaimers

Limited warranty and liability — Information in this document is believed to be accurate and reliable. However, NXP Semiconductors does not give any representations or warranties, expressed or implied, as to the accuracy or completeness of such information and shall have no liability for the consequences of use of such information. NXP Semiconductors takes no responsibility for the content in this document if provided by an information source outside of NXP Semiconductors.

In no event shall NXP Semiconductors be liable for any indirect, incidental, punitive, special or consequential damages (including - without limitation - lost profits, lost savings, business interruption, costs related to the removal or replacement of any products or rework charges) whether or not such damages are based on tort (including negligence), warranty, breach of contract or any other legal theory.

Notwithstanding any damages that customer might incur for any reason whatsoever, NXP Semiconductors' aggregate and cumulative liability towards customer for the products described herein shall be limited in accordance with the *Terms and conditions of commercial sale* of NXP Semiconductors.

Right to make changes — NXP Semiconductors reserves the right to make changes to information published in this document, including without limitation specifications and product descriptions, at any time and without notice. This document supersedes and replaces all information supplied prior to the publication hereof.

Suitability for use — NXP Semiconductors products are not designed, authorized or warranted to be suitable for use in life support, life-critical or safety-critical systems or equipment, nor in applications where failure or malfunction of an NXP Semiconductors product can reasonably be expected to result in personal injury, death or severe property or environmental damage. NXP Semiconductors and its suppliers accept no liability for inclusion and/or use of NXP Semiconductors products in such equipment or applications and therefore such inclusion and/or use is at the customer's own risk.

Applications — Applications that are described herein for any of these products are for illustrative purposes only. NXP Semiconductors makes no representation or warranty that such applications will be suitable for the specified use without further testing or modification.

Customers are responsible for the design and operation of their applications and products using NXP Semiconductors products, and NXP Semiconductors accepts no liability for any assistance with applications or customer product design. It is customer's sole responsibility to determine whether the NXP Semiconductors product is suitable and fit for the customer's applications and products planned, as well as for the planned application and use of customer's third party customer(s). Customers should provide appropriate design and operating safeguards to minimize the risks associated with their applications and products.

NXP Semiconductors does not accept any liability related to any default, damage, costs or problem which is based on any weakness or default in the customer's applications or products, or the application or use by customer's third party customer(s). Customer is responsible for doing all necessary testing for the customer's applications and products using NXP Semiconductors products in order to avoid a default of the applications and the products or of the application or use by customer's third party customer(s). NXP does not accept any liability in this respect.

Limiting values — Stress above one or more limiting values (as defined in the Absolute Maximum Ratings System of IEC 60134) will cause permanent damage to the device. Limiting values are stress ratings only and (proper) operation of the device at these or any other conditions above those given in the Recommended operating conditions section (if present) or the Characteristics sections of this document is not warranted. Constant or repeated exposure to limiting values will permanently and irreversibly affect the quality and reliability of the device.

Terms and conditions of commercial sale — NXP Semiconductors products are sold subject to the general terms and conditions of commercial sale, as published at <http://www.nxp.com/profile/terms>, unless otherwise agreed in a valid written individual agreement. In case an individual agreement is concluded only the terms and conditions of the respective agreement shall apply. NXP Semiconductors hereby expressly objects to applying the customer's general terms and conditions with regard to the purchase of NXP Semiconductors products by customer.

No offer to sell or license — Nothing in this document may be interpreted or construed as an offer to sell products that is open for acceptance or the grant, conveyance or implication of any license under any copyrights, patents or other industrial or intellectual property rights.

Export control — This document as well as the item(s) described herein may be subject to export control regulations. Export might require a prior authorization from competent authorities.

Non-automotive qualified products — Unless this data sheet expressly states that this specific NXP Semiconductors product is automotive qualified, the product is not suitable for automotive use. It is neither qualified nor tested in accordance with automotive testing or application requirements. NXP Semiconductors accepts no liability for inclusion and/or use of non-automotive qualified products in automotive equipment or applications.

In the event that customer uses the product for design-in and use in automotive applications to automotive specifications and standards, customer (a) shall use the product without NXP Semiconductors' warranty of the product for such automotive applications, use and specifications, and (b) whenever customer uses the product for automotive applications beyond

NXP Semiconductors' specifications such use shall be solely at customer's own risk, and (c) customer fully indemnifies NXP Semiconductors for any liability, damages or failed product claims resulting from customer design and use of the product for automotive applications beyond NXP Semiconductors' standard warranty and NXP Semiconductors' product specifications.

Translations — A non-English (translated) version of a document is for reference only. The English version shall prevail in case of any discrepancy between the translated and English versions.

15.4 Trademarks

Notice: All referenced brands, product names, service names and trademarks are the property of their respective owners.

16. Contact information

For more information, please visit: <http://www.nxp.com>

For sales office addresses, please send an email to: salesaddresses@nxp.com

17. Contents

1	General description	1
2	Features and benefits	1
3	Ordering information	2
4	Functional diagram	2
5	Pinning information	4
5.1	Pinning	4
5.2	Pin description	4
6	Functional description	5
7	Limiting values	6
8	Recommended operating conditions	6
9	Static characteristics	7
10	Dynamic characteristics	8
11	Waveforms	10
12	Package outline	14
13	Abbreviations	18
14	Revision history	18
15	Legal information	19
15.1	Data sheet status	19
15.2	Definitions	19
15.3	Disclaimers	19
15.4	Trademarks	20
16	Contact information	20
17	Contents	21

Please be aware that important notices concerning this document and the product(s) described herein, have been included in section 'Legal information'.

© NXP B.V. 2014.

All rights reserved.

For more information, please visit: <http://www.nxp.com>

For sales office addresses, please send an email to: salesaddresses@nxp.com

Date of release: 19 February 2014

Document identifier: 74LV165



LittleDiode supplies new, hard to find or obsolete electronic components and semiconductors all over the world.

With over two million different components listed you are sure to find the part you need.

Feel free to visit us today at our online store:

LittleDiode.com

Looking forward to providing you with the best possible service.