

74LV259

8-bit addressable latch

Rev. 03 — 2 January 2008

Product data sheet

1. General description

The 74LV259 is a low-voltage Si-gate CMOS device that is pin and function compatible with 74HC259 and 74HCT259. The 74LV259 is a high-speed 8-bit addressable latch designed for general purpose storage applications in digital systems. The 74LV259 is multifunctional device capable of storing single-line data in eight addressable latches, and also 3-to-8 decoder and demultiplexer, with active HIGH outputs (Q0 to Q7), functions are available. The 74LV259 also incorporates an active LOW common reset (\overline{MR}) for resetting all latches, as well as, an active LOW enable input (\overline{LE}).

The 74LV259 has four modes of operation as shown in the mode select table. In the addressable latch mode, data on the data line (D) is written into the addressed latch. The addressed latch will follow the data input with all non-addressed latches remaining in their previous states. In the memory mode, all latches remain in their previous states and are unaffected by the data or address inputs. In the 3-to-8 decoding or demultiplexing mode, the addressed output follows the state of the (D) input with all other outputs in the LOW state. In the reset mode all outputs are LOW and unaffected by the address (A0 to A2) and data (D) input. When operating the 74LV259 as an address latch, changing more than one bit of address could impose a transient-wrong address. Therefore, this should only be done while in the memory mode.

2. Features

- Optimized for low voltage applications: 1.0 V to 3.6 V
- Accepts TTL input levels between $V_{CC} = 2.7$ V and $V_{CC} = 3.6$ V
- Typical output ground bounce < 0.8 V at $V_{CC} = 3.3$ V and $T_{amb} = 25$ °C
- Typical HIGH-level output voltage (V_{OH}) undershoot: > 2 V at $V_{CC} = 3.3$ V and $T_{amb} = 25$ °C
- Combines demultiplexer and 8-bit latch
- Serial-to-parallel capability
- Output from each storage bit available
- Random (addressable) data entry
- Easily expandable
- Common reset input
- Useful as a 3-to-8 active HIGH decoder
- ESD protection:
 - ◆ HBM JESD22-A114E exceeds 2000 V
 - ◆ MM JESD22-A115-A exceeds 200 V
- Multiple package options
- Specified from -40 °C to $+85$ °C and from -40 °C to $+125$ °C

3. Ordering information

Table 1. Ordering information

Type number	Package			Version
	Temperature range	Name	Description	
74LV259N	-40 °C to +125 °C	DIP16	plastic dual in-line package; 16 leads (300 mil)	SOT38-4
74LV259D	-40 °C to +125 °C	SO16	plastic small outline package; 16 leads; body width 3.9 mm	SOT109-1
74LV259DB	-40 °C to +125 °C	SSOP16	plastic shrink small outline package; 16 leads; body width 5.3 mm	SOT338-1
74LV259PW	-40 °C to +125 °C	TSSOP16	plastic thin shrink small outline package; 16 leads; body width 4.4 mm	SOT403-1
74LV259BQ	-40 °C to +125 °C	DHVQFN16	plastic dual in-line compatible thermal enhanced very thin quad flat package; no leads; 16 terminals; body 2.5 × 3.5 × 0.85 mm	SOT763-1

4. Functional diagram

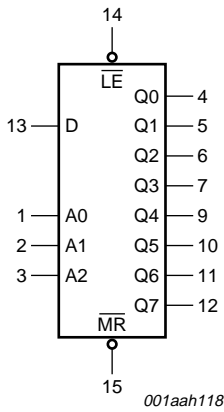

Fig 1. Logic symbol

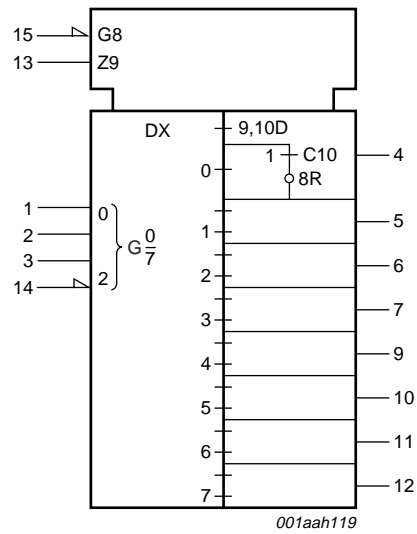

Fig 2. IEC logic symbol

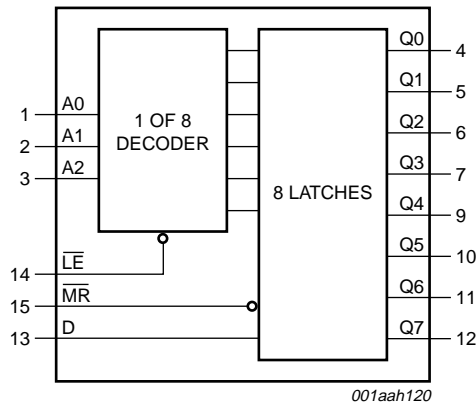

Fig 3. Functional diagram

5. Pinning information

5.1 Pinning

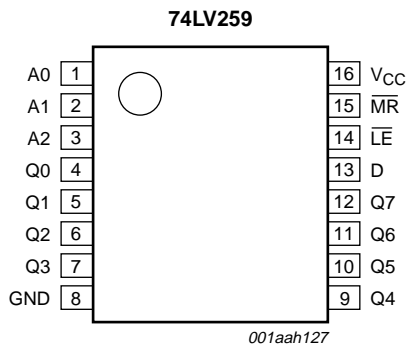
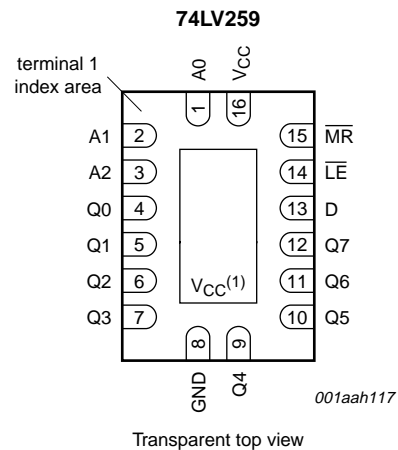

Fig 4. Pin configuration DIP16, SO16 and (T)SSOP16



(1) The die substrate is attached to this pad using conductive die attach material. It can not be used as a supply pin or input.

Fig 5. Pin configuration DHVQFN16

5.2 Pin description

Table 2. Pin description

Symbol	Pin	Description
A0	1	address input
A1	2	address input
A2	3	address input
GND	8	ground (0 V)
Q[0:7]	4, 5, 6, 7, 9, 10, 11, 12	latch output

Table 2. Pin description ...continued

Symbol	Pin	Description
D	13	data input
\overline{LE}	14	latch enable input (active LOW)
\overline{MR}	15	conditional reset input (active LOW)
V _{CC}	16	supply voltage

6. Functional description

Table 3. Mode select table

H = HIGH voltage level; L = LOW voltage level

\overline{LE}	\overline{MR}	Mode
L	H	addressable latch
H	H	memory
L	L	active HIGH 8-channel demultiplexer
H	L	reset

Table 4. Function table

H = HIGH voltage level; L = LOW voltage level; X = don't care; d = High or LOW data one set-up time prior to the LOW-to-HIGH \overline{LE} transition; q<n> = state of the output established during the last cycle in which it was addressed or cleared

Operating modes	Input						Output							
	\overline{MR}	\overline{LE}	D	A0	A1	A2	Q0	Q1	Q2	Q3	Q4	Q5	Q6	Q7
master reset	L	H	X	X	X	X	L	L	L	L	L	L	L	L
demultiplex (active HIGH) decoder (when D = H)	L	L	d	L	L	L	Q = d	L	L	L	L	L	L	L
	L	L	d	H	L	L	L	Q = d	L	L	L	L	L	L
	L	L	d	L	H	L	L	L	Q = d	L	L	L	L	L
	L	L	d	H	H	L	L	L	L	Q = d	L	L	L	L
	L	L	d	L	L	H	L	L	L	L	Q = d	L	L	L
	L	L	d	H	L	H	L	L	L	L	L	Q = d	L	L
	L	L	d	L	H	H	L	L	L	L	L	L	Q = d	L
	L	L	d	H	H	H	L	L	L	L	L	L	L	Q = d
store (do nothing)	H	H	X	X	X	X	q0	q1	q2	q3	q4	q5	q6	q7
addressable latch	H	L	d	L	L	L	Q = d	q1	q2	q3	q4	q5	q6	q7
	H	L	d	H	L	L	q0	Q = d	q2	q3	q4	q5	q6	q7
	H	L	d	L	H	L	q0	q1	Q = d	q3	q4	q5	q6	q7
	H	L	d	H	H	L	q0	q1	q2	Q = d	q4	q5	q6	q7
	H	L	d	L	L	H	q0	q1	q2	q3	Q = d	q5	q6	q7
	H	L	d	H	L	H	q0	q1	q2	q3	q4	Q = d	q6	q7
	H	L	d	L	H	H	q0	q1	q2	q3	q4	q5	Q = d	q7
	H	L	H	H	H	H	q0	q1	q2	q3	q4	q5	q6	Q = d

7. Limiting values

Table 5. Limiting values

In accordance with the Absolute Maximum Rating System (IEC 60134). Voltages are referenced to GND (ground = 0 V).

Symbol	Parameter	Conditions	Min	Max	Unit
V_{CC}	supply voltage		-0.5	+4.6	V
I_{IK}	input clamping current	$V_I < -0.5\text{ V}$ or $V_I > V_{CC} + 0.5\text{ V}$	[1] -	±20	mA
I_{OK}	output clamping current	$V_O < -0.5\text{ V}$ or $V_O > V_{CC} + 0.5\text{ V}$	[1] -	±50	mA
I_O	output current	$V_O = -0.5\text{ V}$ to $(V_{CC} + 0.5\text{ V})$	-	±25	mA
I_{CC}	supply current		-	50	mA
I_{GND}	ground current		-50	-	mA
T_{stg}	storage temperature		-65	+150	°C
P_{tot}	total power dissipation	$T_{amb} = -40\text{ °C}$ to $+125\text{ °C}$			
		DIP16 package	[2] -	750	mW
		SO16 package	[3] -	500	mW
		(T)SSOP16 package	[4] -	500	mW
		DHVQFN16 package	[5] -	500	mW

[1] The input and output voltage ratings may be exceeded if the input and output current ratings are observed.

[2] P_{tot} derates linearly with 12 mW/K above 70 °C.

[3] P_{tot} derates linearly with 8 mW/K above 70 °C.

[4] P_{tot} derates linearly with 5.5 mW/K above 60 °C.

[5] P_{tot} derates linearly with 4.5 mW/K above 60 °C.

8. Recommended operating conditions

Table 6. Recommended operating conditions

Voltages are referenced to GND (ground = 0 V).

Symbol	Parameter	Conditions	Min	Typ	Max	Unit
V_{CC}	supply voltage		[1] 1.0	3.3	3.6	V
V_I	input voltage		0	-	V_{CC}	V
V_O	output voltage		0	-	V_{CC}	V
T_{amb}	ambient temperature		-40	+25	+125	°C
$\Delta t/\Delta V$	input transition rise and fall rate	$V_{CC} = 1.0\text{ V}$ to 2.0 V	-	-	500	ns/V
		$V_{CC} = 2.0\text{ V}$ to 2.7 V	-	-	200	ns/V
		$V_{CC} = 2.7\text{ V}$ to 3.6 V	-	-	100	ns/V

[1] The static characteristics are guaranteed from $V_{CC} = 1.2\text{ V}$ to $V_{CC} = 5.5\text{ V}$, but LV devices are guaranteed to function down to $V_{CC} = 1.0\text{ V}$ (with input levels GND or V_{CC}).

9. Static characteristics

Table 7. Static characteristics

Voltages are referenced to GND (ground = 0 V).

Symbol	Parameter	Conditions	-40 °C to +85 °C			-40 °C to +125 °C		Unit
			Min	Typ ^[1]	Max	Min	Max	
V _{IH}	HIGH-level input voltage	V _{CC} = 1.2 V	0.9	-	-	0.9	-	V
		V _{CC} = 2.0 V	1.4	-	-	1.4	-	V
		V _{CC} = 2.7 V to 3.6 V	2.0	-	-	2.0	-	V
V _{IL}	LOW-level input voltage	V _{CC} = 1.2 V	-	-	0.3	-	0.3	V
		V _{CC} = 2.0 V	-	-	0.6	-	0.6	V
		V _{CC} = 2.7 V to 3.6 V	-	-	0.8	-	0.8	V
V _{OH}	HIGH-level output voltage	V _I = V _{IH} or V _{IL}						
		I _O = -100 μA; V _{CC} = 1.2 V	-	1.2	-	-	-	V
		I _O = -100 μA; V _{CC} = 2.0 V	1.8	2.0	-	1.8	-	V
		I _O = -100 μA; V _{CC} = 2.7 V	2.5	2.7	-	2.5	-	V
		I _O = -100 μA; V _{CC} = 3.0 V	2.8	3.0	-	2.8	-	V
		I _O = -6 mA; V _{CC} = 3.0 V	2.4	2.82	-	2.2	-	V
V _{OL}	LOW-level output voltage	V _I = V _{IH} or V _{IL}						
		I _O = 100 μA; V _{CC} = 1.2 V	-	0	-	-	-	V
		I _O = 100 μA; V _{CC} = 2.0 V	-	0	0.2	-	0.2	V
		I _O = 100 μA; V _{CC} = 2.7 V	-	0	0.2	-	0.2	V
		I _O = 100 μA; V _{CC} = 3.0 V	-	0	0.2	-	0.2	V
		I _O = 6 mA; V _{CC} = 3.0 V	-	0.25	0.40	-	0.50	V
I _I	input leakage current	V _I = V _{CC} or GND; V _{CC} = 5.5 V	-	-	1.0	-	1.0	μA
I _{CC}	supply current	V _I = V _{CC} or GND; I _O = 0 A; V _{CC} = 5.5 V	-	-	20.0	-	160	μA
ΔI _{CC}	additional supply current	per input; V _I = V _{CC} - 0.6 V; V _{CC} = 2.7 V to 3.6 V	-	-	500	-	850	μA
C _I	input capacitance		-	3.5	-	-	-	pF

[1] Typical values are measured at T_{amb} = 25 °C.

10. Dynamic characteristics

Table 8. Dynamic characteristics
GND = 0 V; For test circuit see Figure 12.

Symbol	Parameter	Conditions	-40 °C to +85 °C			-40 °C to +125 °C		Unit
			Min	Typ ^[1]	Max	Min	Max	
t _{pd}	propagation delay	D to Qn; see Figure 8 ^[2]						
		V _{CC} = 1.2 V	-	105	-	-	-	ns
		V _{CC} = 2.0 V	-	36	49	-	61	ns
		V _{CC} = 2.7 V	-	26	36	-	45	ns
		V _{CC} = 3.0 V to 3.6 V; C _L = 15 pF ^[3]	-	17	-	-	-	ns
		V _{CC} = 3.0 V to 3.6 V ^[3]	-	20	29	-	36	ns
t _{pd}	propagation delay	An to Qn; see Figure 7 ^[2]						
		V _{CC} = 1.2 V	-	105	-	-	-	ns
		V _{CC} = 2.0 V	-	36	49	-	61	ns
		V _{CC} = 2.7 V	-	26	36	-	45	ns
		V _{CC} = 3.0 V to 3.6 V; C _L = 15 pF ^[3]	-	17	-	-	-	ns
		V _{CC} = 3.0 V to 3.6 V ^[3]	-	20	29	-	36	ns
t _{pd}	propagation delay	$\overline{\text{LE}}$ to Qn; Figure 6 ^[2]						
		V _{CC} = 1.2 V	-	100	-	-	-	ns
		V _{CC} = 2.0 V	-	34	48	-	60	ns
		V _{CC} = 2.7 V	-	25	35	-	44	ns
		V _{CC} = 3.0 V to 3.6 V; C _L = 15 pF ^[3]	-	16	-	-	-	ns
		V _{CC} = 3.0 V to 3.6 V ^[3]	-	19	28	-	35	ns
t _{PHL}	HIGH to LOW propagation delay	$\overline{\text{MR}}$ to Qn; Figure 9						
		V _{CC} = 1.2 V	-	90	-	-	-	ns
		V _{CC} = 2.0 V	-	31	43	-	53	ns
		V _{CC} = 2.7 V	-	23	31	-	39	ns
		V _{CC} = 3.0 V to 3.6 V; C _L = 15 pF ^[3]	-	14	-	-	-	ns
		V _{CC} = 3.0 V to 3.6 V ^[3]	-	17	25	-	31	ns
t _w	pulse width	$\overline{\text{LE}}$, HIGH or LOW; see Figure 6						
		V _{CC} = 2.0 V	34	10	-	41	-	ns
		V _{CC} = 2.7 V	25	8	-	30	-	ns
		V _{CC} = 3.0 V to 3.6 V ^[3]	20	6	-	24	-	ns
t _w	pulse width	$\overline{\text{MR}}$, LOW; see Figure 9						
		V _{CC} = 2.0 V	34	10	-	41	-	ns
		V _{CC} = 2.7 V	25	8	-	30	-	ns
		V _{CC} = 3.0 V to 3.6 V ^[3]	20	6	-	24	-	ns

Table 8. Dynamic characteristics ...continued
GND = 0 V; For test circuit see Figure 12.

Symbol	Parameter	Conditions	-40 °C to +85 °C			-40 °C to +125 °C		Unit
			Min	Typ ^[1]	Max	Min	Max	
t _{su}	set-up time	D, An to \overline{LE} ; see Figure 10 and Figure 11						
		V _{CC} = 1.2 V	-	35	-	-	-	ns
		V _{CC} = 2.0 V	24	12	-	29	-	ns
		V _{CC} = 2.7 V	18	9	-	21	-	ns
		V _{CC} = 3.0 V to 3.6 V ^[3]	14	7	-	17	-	ns
t _h	hold time	D to \overline{LE} ; see Figure 10						
		V _{CC} = 1.2 V	-	-30	-	-	-	ns
		V _{CC} = 2.0 V	5	-10	-	5	-	ns
		V _{CC} = 2.7 V	5	-8	-	5	-	ns
		V _{CC} = 3.0 V to 3.6 V ^[3]	5	-6	-	5	-	ns
t _h	hold time	An to \overline{LE} ; see Figure 11						
		V _{CC} = 1.2 V	-	-20	-	-	-	ns
		V _{CC} = 2.0 V	5	-7	-	5	-	ns
		V _{CC} = 2.7 V	5	-5	-	5	-	ns
		V _{CC} = 3.0 V to 3.6 V ^[3]	5	-4	-	5	-	ns
C _{PD}	power dissipation capacitance	C _L = 50 pF; f _i = 1 MHz; V _i = GND to V _{CC} ^[4]		19				pF

- [1] Typical values are measured at T_{amb} = 25 °C.
- [2] t_{pd} is the same as t_{PLH} and t_{PHL}.
- [3] Typical value measured at V_{CC} = 3.3 V.
- [4] C_{PD} is used to determine the dynamic power dissipation (P_D in μW).
 $P_D = C_{PD} \times V_{CC}^2 \times f_i \times N + \sum(C_L \times V_{CC}^2 \times f_o)$ where:
 f_i = input frequency in MHz;
 f_o = output frequency in MHz;
 C_L = output load capacitance in pF;
 V_{CC} = supply voltage in V;
 N = number of inputs switching;
 $\sum(C_L \times V_{CC}^2 \times f_o)$ = sum of outputs.

11. Waveforms

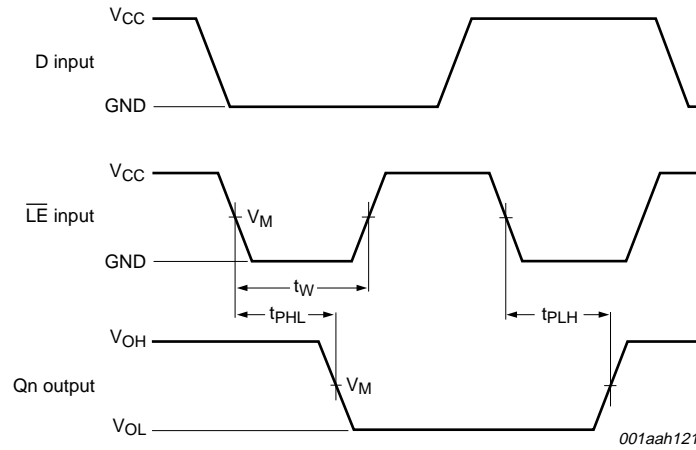

Measurement points are given in [Table 9](#).

V_{OL} and V_{OH} are typical voltage output levels that occur with the output load.

Fig 6. The enable input (\overline{LE}) to output (Q_n) propagation delays and the enable input pulse width

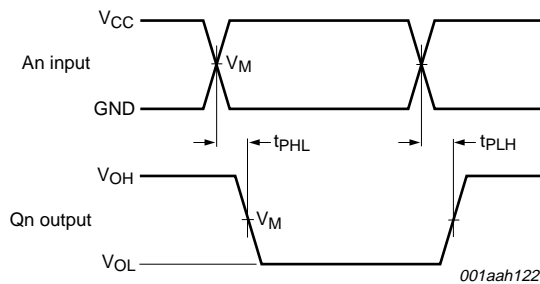

Measurement points are given in [Table 9](#).

V_{OL} and V_{OH} are typical voltage output levels that occur with the output load.

Fig 7. The address input (A_n) to output (Q_n) propagation delays

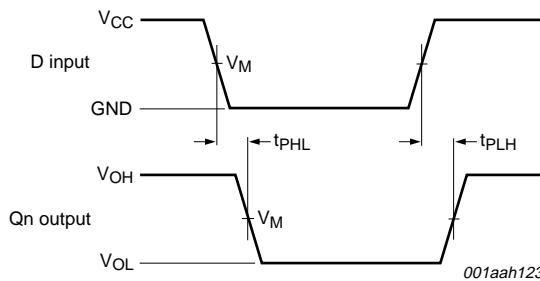

Measurement points are given in [Table 9](#).

V_{OL} and V_{OH} are typical voltage output levels that occur with the output load.

Fig 8. The data input (D) to output (Q_n) propagation delays

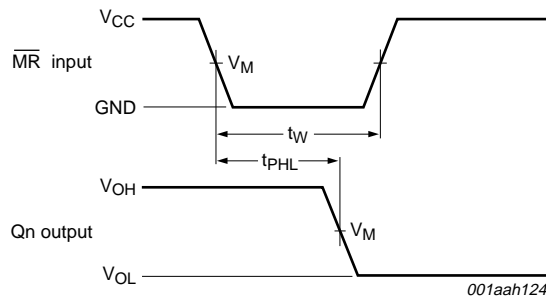

Measurement points are given in [Table 9](#).

V_{OL} and V_{OH} are typical voltage output levels that occur with the output load.

Fig 9. The conditional reset input (\overline{MR}) to output (Q_n) propagation delays

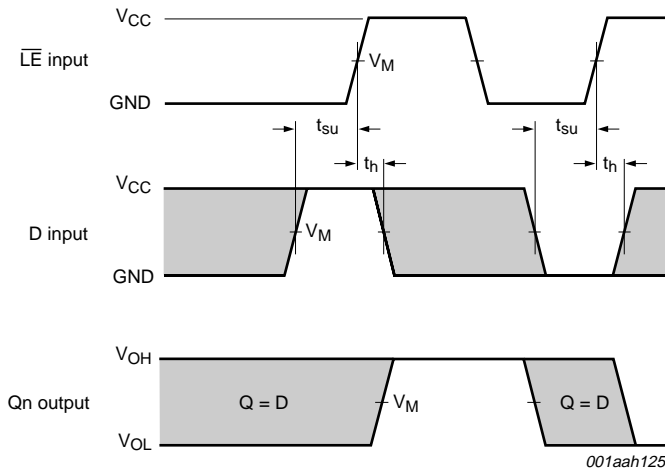

Measurement points are given in [Table 9](#).

V_{OL} and V_{OH} are typical voltage output levels that occur with the output load.

Fig 10. The data set-up and hold times for the D input to the \overline{LE} input

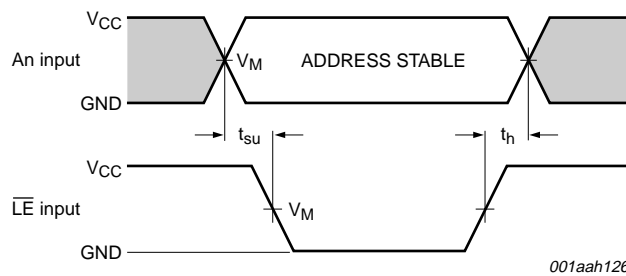

Measurement points are given in [Table 9](#).

V_{OL} and V_{OH} are typical voltage output levels that occur with the output load.

Fig 11. The address input set-up and hold times for the A_n inputs to the \overline{LE} input

Table 9. Measurement points

Supply voltage V_{CC}	Input V_M	Output V_M
< 2.7 V	$0.5V_{CC}$	$0.5V_{CC}$
2.7 V to 3.6 V	1.5 V	1.5 V

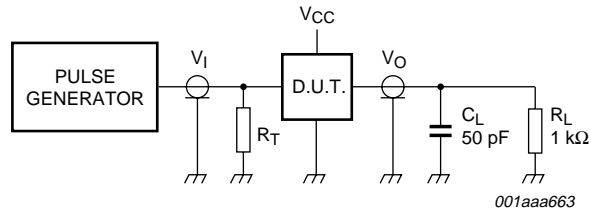

Test data is given in [Table 10](#).

Definitions test circuit:

R_T = Termination resistance should be equal to output impedance Z_o of the pulse generator.

R_L = Load resistance.

C_L = Load capacitance including jig and probe capacitance.

Fig 12. Load circuit for switching times

Table 10. Test data

Supply voltage V_{CC}	Input V_I	t_r, t_f
< 2.7 V	V_{CC}	≤ 2.5 ns
2.7 V to 3.6 V	2.7 V	≤ 2.5 ns

12. Package outline

DIP16: plastic dual in-line package; 16 leads (300 mil)

SOT38-4

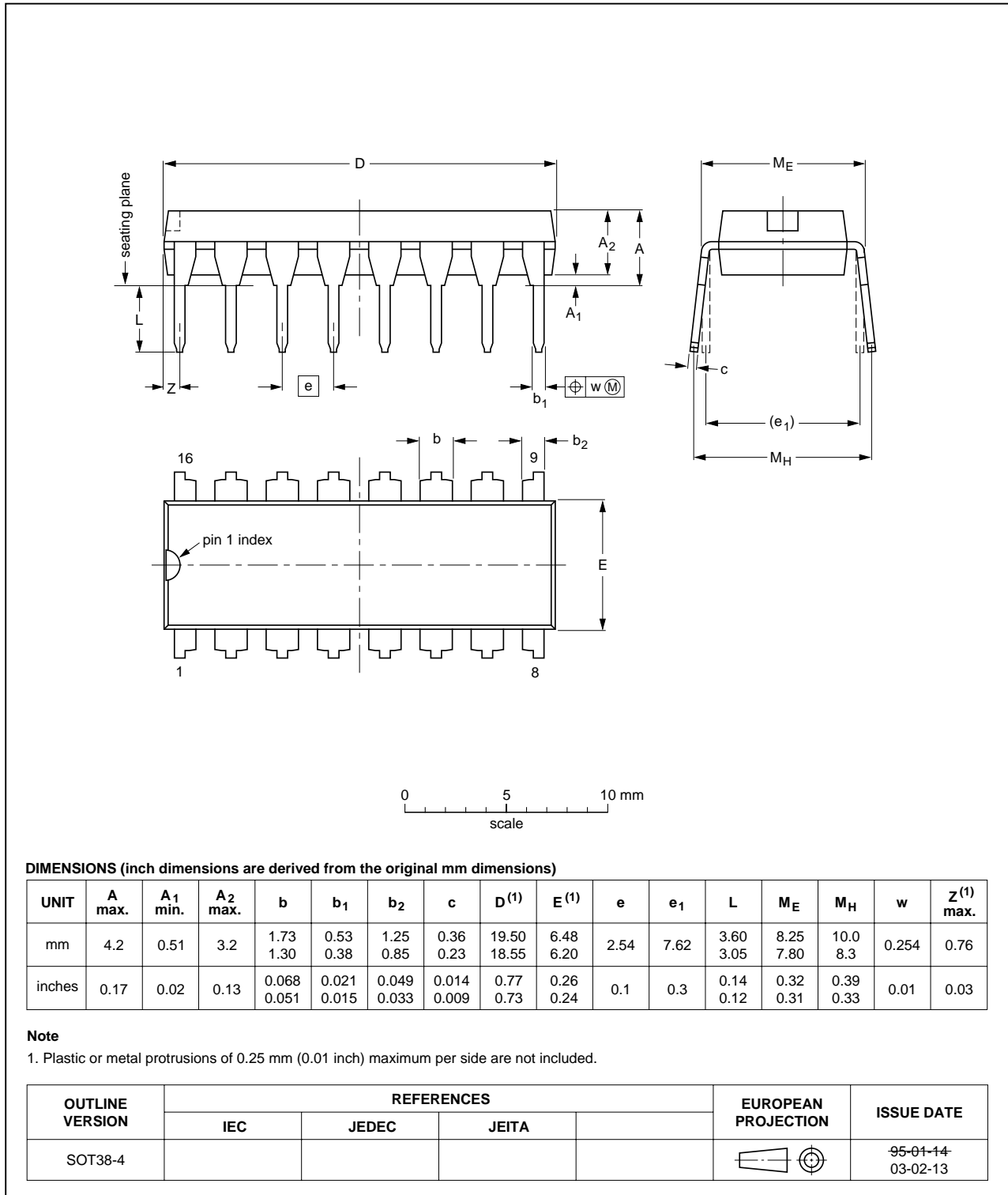

Fig 13. Package outline SOT38-4 (DIP16)

SO16: plastic small outline package; 16 leads; body width 3.9 mm

SOT109-1

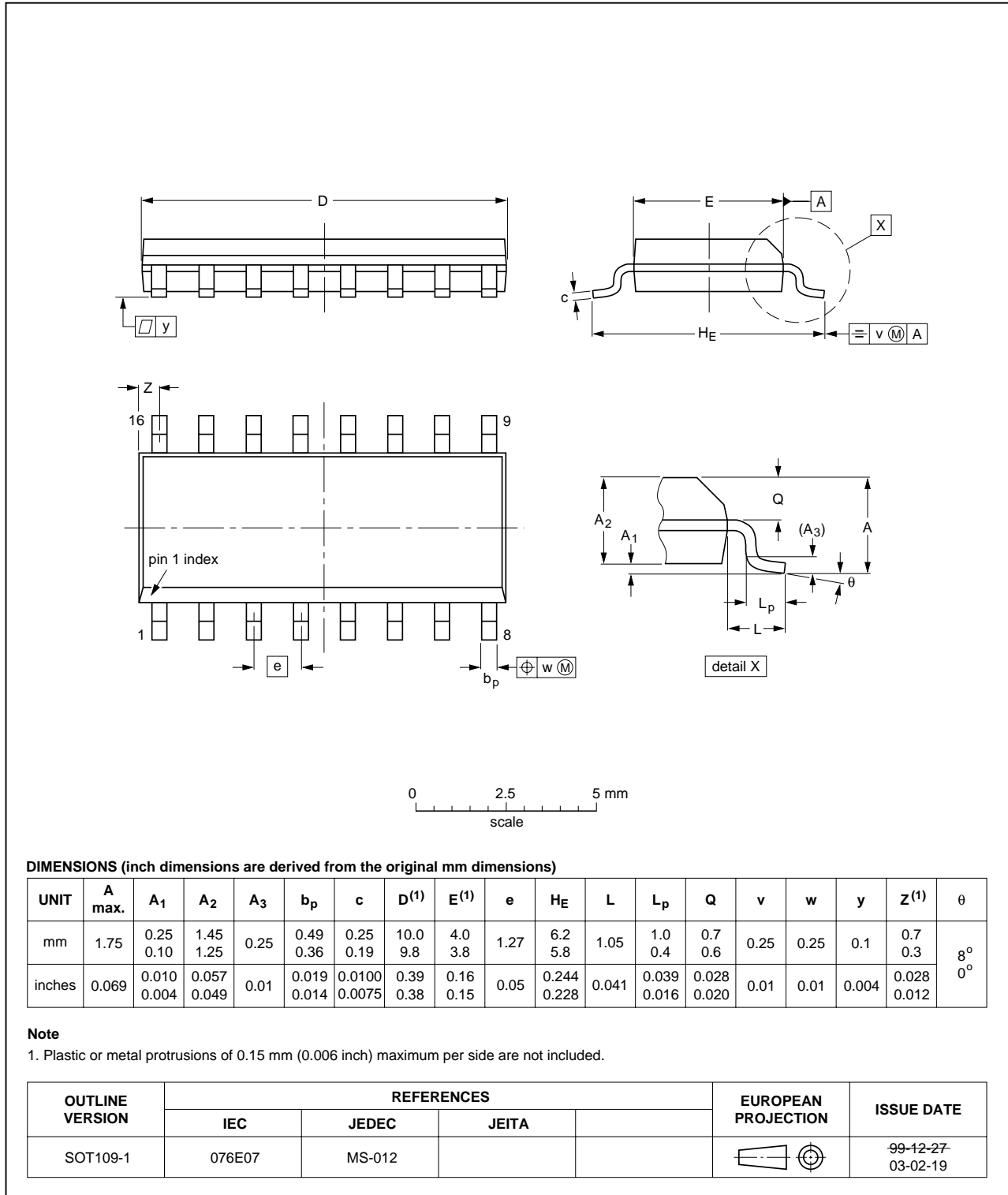

Fig 14. Package outline SOT109-1 (SO16)

SSOP16: plastic shrink small outline package; 16 leads; body width 5.3 mm

SOT338-1

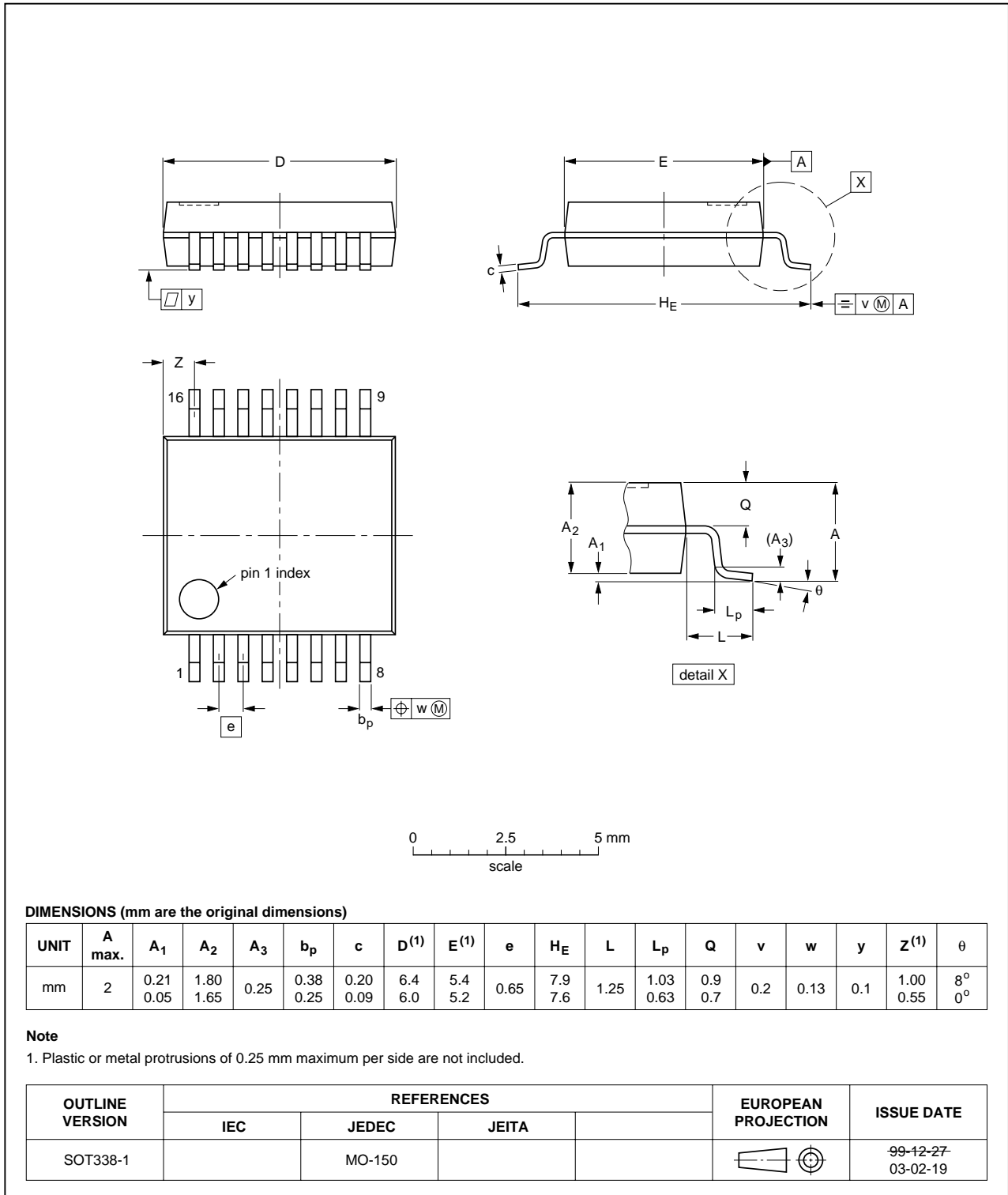

Fig 15. Package outline SOT338-1 (SSOP16)

TSSOP16: plastic thin shrink small outline package; 16 leads; body width 4.4 mm

SOT403-1

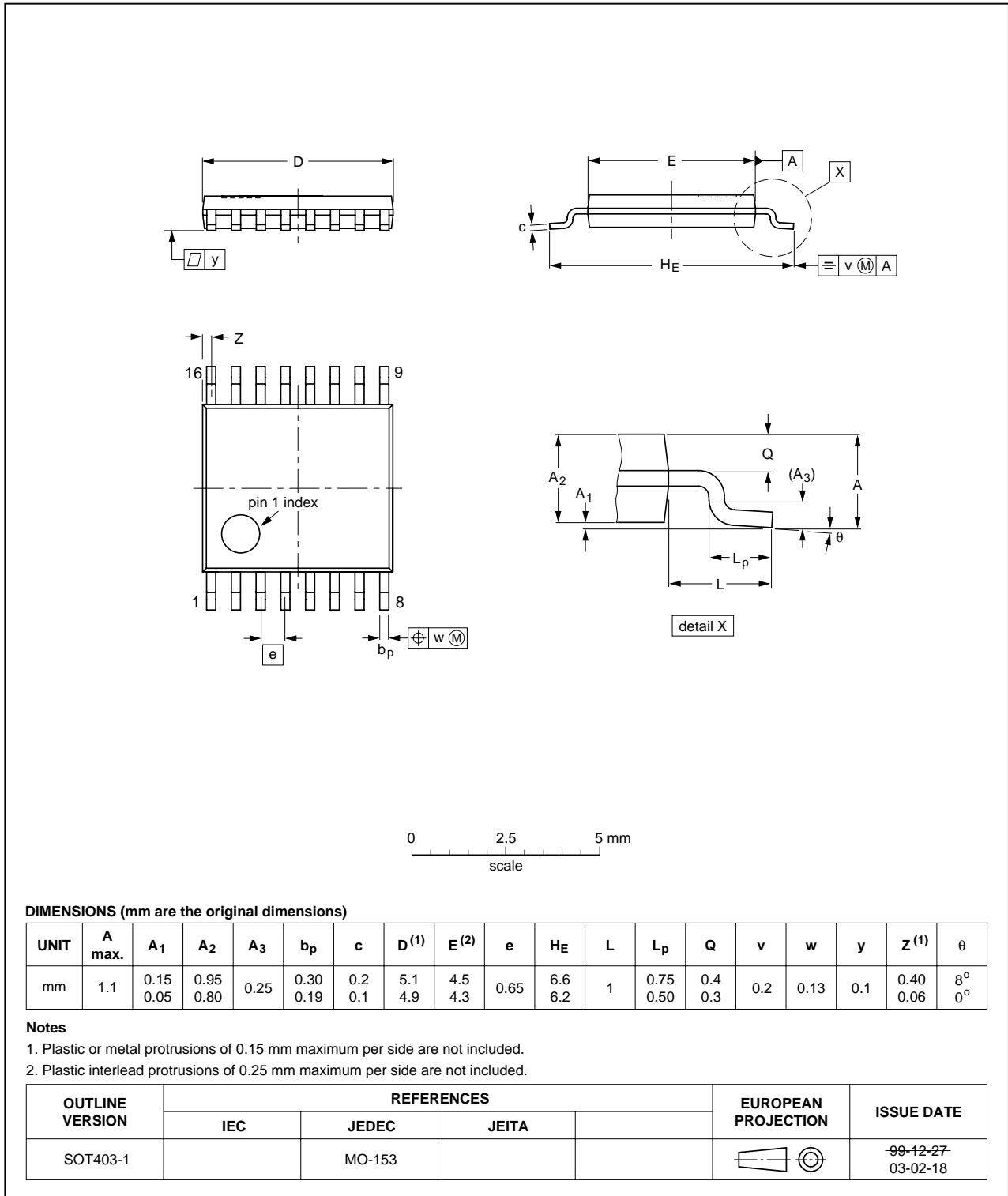

Fig 16. Package outline SOT403-1 (TSSOP16)

DHVQFN16: plastic dual in-line compatible thermal enhanced very thin quad flat package; no leads; 16 terminals; body 2.5 x 3.5 x 0.85 mm

SOT763-1

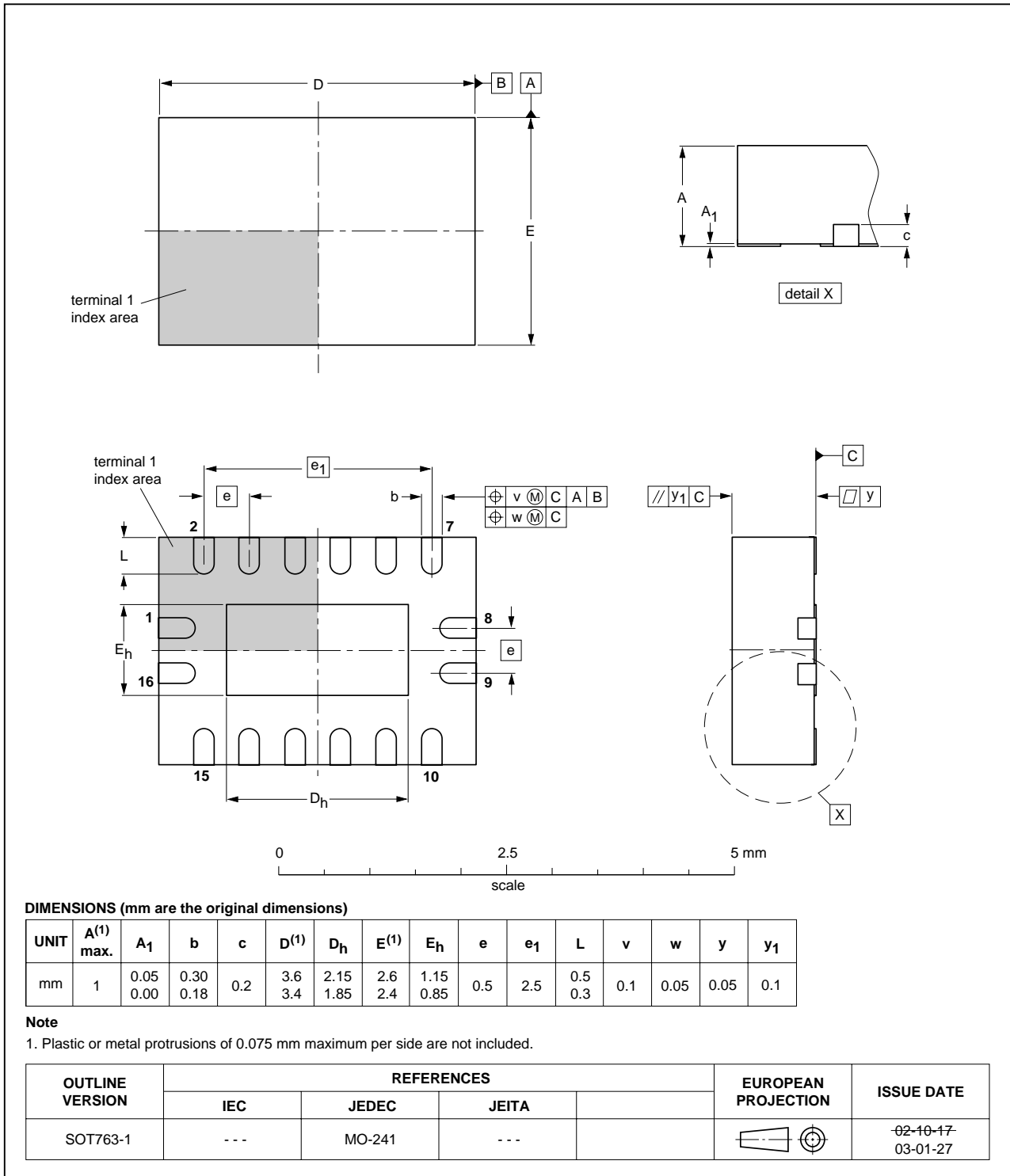

Fig 17. Package outline SOT763-1 (DHVQFN16)

13. Abbreviations

Table 11. Abbreviations

Acronym	Description
CMOS	Complementary Metal Oxide Semiconductor
DUT	Device Under Test
ESD	ElectroStatic Discharge
HBM	Human Body Model
MM	Machine Model
TTL	Transistor-Transistor Logic

14. Revision history

Table 12. Revision history

Document ID	Release date	Data sheet status	Change notice	Supersedes
74LV259_3	20080102	Product data sheet	-	74LV259_2
Modifications:	<ul style="list-style-type: none"> The format of this data sheet has been redesigned to comply with the new identity guidelines of NXP Semiconductors. Legal texts have been adapted to the new company name where appropriate. Section 3: DHVQFN16 package added. Section 7: derating values added for DHVQFN16 package. Section 12: outline drawing added for DHVQFN16 package. 			
74LV259_2	19980520	Product specification	-	74LV259_1
74LV259_1	19970606	Product specification	-	-

15. Legal information

15.1 Data sheet status

Document status ^{[1][2]}	Product status ^[3]	Definition
Objective [short] data sheet	Development	This document contains data from the objective specification for product development.
Preliminary [short] data sheet	Qualification	This document contains data from the preliminary specification.
Product [short] data sheet	Production	This document contains the product specification.

[1] Please consult the most recently issued document before initiating or completing a design.

[2] The term 'short data sheet' is explained in section "Definitions".

[3] The product status of device(s) described in this document may have changed since this document was published and may differ in case of multiple devices. The latest product status information is available on the Internet at URL <http://www.nxp.com>.

15.2 Definitions

Draft — The document is a draft version only. The content is still under internal review and subject to formal approval, which may result in modifications or additions. NXP Semiconductors does not give any representations or warranties as to the accuracy or completeness of information included herein and shall have no liability for the consequences of use of such information.

Short data sheet — A short data sheet is an extract from a full data sheet with the same product type number(s) and title. A short data sheet is intended for quick reference only and should not be relied upon to contain detailed and full information. For detailed and full information see the relevant full data sheet, which is available on request via the local NXP Semiconductors sales office. In case of any inconsistency or conflict with the short data sheet, the full data sheet shall prevail.

15.3 Disclaimers

General — Information in this document is believed to be accurate and reliable. However, NXP Semiconductors does not give any representations or warranties, expressed or implied, as to the accuracy or completeness of such information and shall have no liability for the consequences of use of such information.

Right to make changes — NXP Semiconductors reserves the right to make changes to information published in this document, including without limitation specifications and product descriptions, at any time and without notice. This document supersedes and replaces all information supplied prior to the publication hereof.

Suitability for use — NXP Semiconductors products are not designed, authorized or warranted to be suitable for use in medical, military, aircraft, space or life support equipment, nor in applications where failure or

malfunction of an NXP Semiconductors product can reasonably be expected to result in personal injury, death or severe property or environmental damage. NXP Semiconductors accepts no liability for inclusion and/or use of NXP Semiconductors products in such equipment or applications and therefore such inclusion and/or use is at the customer's own risk.

Applications — Applications that are described herein for any of these products are for illustrative purposes only. NXP Semiconductors makes no representation or warranty that such applications will be suitable for the specified use without further testing or modification.

Limiting values — Stress above one or more limiting values (as defined in the Absolute Maximum Ratings System of IEC 60134) may cause permanent damage to the device. Limiting values are stress ratings only and operation of the device at these or any other conditions above those given in the Characteristics sections of this document is not implied. Exposure to limiting values for extended periods may affect device reliability.

Terms and conditions of sale — NXP Semiconductors products are sold subject to the general terms and conditions of commercial sale, as published at <http://www.nxp.com/profile/terms>, including those pertaining to warranty, intellectual property rights infringement and limitation of liability, unless explicitly otherwise agreed to in writing by NXP Semiconductors. In case of any inconsistency or conflict between information in this document and such terms and conditions, the latter will prevail.

No offer to sell or license — Nothing in this document may be interpreted or construed as an offer to sell products that is open for acceptance or the grant, conveyance or implication of any license under any copyrights, patents or other industrial or intellectual property rights.

15.4 Trademarks

Notice: All referenced brands, product names, service names and trademarks are the property of their respective owners.

16. Contact information

For additional information, please visit: <http://www.nxp.com>

For sales office addresses, send an email to: salesaddresses@nxp.com

17. Contents

1	General description	1
2	Features	1
3	Ordering information	2
4	Functional diagram	2
5	Pinning information	3
5.1	Pinning	3
5.2	Pin description	3
6	Functional description	4
7	Limiting values	5
8	Recommended operating conditions	5
9	Static characteristics	6
10	Dynamic characteristics	7
11	Waveforms	9
12	Package outline	12
13	Abbreviations	17
14	Revision history	17
15	Legal information	18
15.1	Data sheet status	18
15.2	Definitions	18
15.3	Disclaimers	18
15.4	Trademarks	18
16	Contact information	18
17	Contents	19

Please be aware that important notices concerning this document and the product(s) described herein, have been included in section 'Legal information'.



© NXP B.V. 2008.

All rights reserved.

For more information, please visit: <http://www.nxp.com>

For sales office addresses, please send an email to: salesaddresses@nxp.com

Date of release: 2 January 2008

Document identifier: 74LV259_3



LittleDiode supplies new, hard to find or obsolete electronic components and semiconductors all over the world.

With over two million different components listed you are sure to find the part you need.

Feel free to visit us today at our online store:

LittleDiode.com

Looking forward to providing you with the best possible service.