

# DATA SHEET

## **74LV4053**

Triple 2-channel analog  
multiplexer/demultiplexer

Product specification  
Supersedes data of 1997 Jul 15  
IC24 Data Handbook

1998 Jun 23

## Triple 2-channel analog multiplexer/demultiplexer

74LV4053

## FEATURES

- Optimized for low voltage applications: 1.0 to 6.0 V
- Accepts TTL input levels between  $V_{CC} = 2.7$  V and  $V_{CC} = 3.6$  V
- Low typ "ON" resistance:  
100  $\Omega$  at  $V_{CC} - V_{EE} = 4.5$  V  
150  $\Omega$  at  $V_{CC} - V_{EE} = 3.0$  V  
240  $\Omega$  at  $V_{CC} - V_{EE} = 2.0$  V
- Logic level translation: to enable 3 V logic to communicate with  $\pm 3$  V analog signals
- Typical "break before make" built in
- Output capability: non-standard
- $I_{CC}$  category: MSI

## DESCRIPTION

The 74LV4053 is a low-voltage CMOS device and is pin and function compatible with the 74HC/HCT4053.

The 74LV4053 is a triple 2-channel analog multiplexer/demultiplexer with a common enable input ( $\bar{E}$ ). Each multiplexer/demultiplexer has two independent inputs/outputs ( $nY_0$  to  $nY_1$ ), a common input/output ( $nZ$ ) and three digital select inputs ( $S_1$  to  $S_3$ ).

With  $\bar{E}$  LOW, one of the two switches is selected (low impedance ON-state) by  $S_1$  to  $S_3$ . With  $\bar{E}$  HIGH, all switches are in the high impedance OFF-states, independent of  $S_1$  and  $S_3$ .

$V_{CC}$  and GND are the supply voltage pins for the digital control inputs ( $S_1$ , to  $S_3$ , and  $\bar{E}$ ). The  $V_{CC}$  to GND ranges are 1.0 to 6.0 V. The analog inputs/outputs ( $nY_0$ , to  $nY_1$ , and  $nZ$ ) can swing between  $V_{CC}$  as a positive limit and  $V_{EE}$  as a negative limit.  $V_{CC} - V_{EE}$  may not exceed 6.0 V. For operation as a digital multiplexer/demultiplexer,  $V_{EE}$  is connected to GND (typically ground).

## QUICK REFERENCE DATA

GND = 0 V;  $T_{amb} = 25^\circ\text{C}$ ;  $t_r = t_f \leq 2.5$  ns

SYMBOL	PARAMETER	CONDITIONS	TYPICAL	UNIT
$t_{PZH}/t_{PZL}$	Turn "ON" time $\bar{E}$ to $V_{OS}$ $S_n$ to $V_{OS}$	$C_L = 15$ pF $R_L = 1K\Omega$ $V_{CC} = 3.3$ V	16 20	ns
$t_{PHZ}/t_{PLZ}$	Turn "OFF" time $\bar{E}$ to $V_{OS}$ $S_n$ to $V_{OS}$		17 16	
$C_I$	Input capacitance		3.5	pF
$C_{PD}$	Power dissipation capacitance per switch	See Notes 1 and 2	36	
$C_S$	Maximum switch capacitance independent (Y) common (Z)		5 8	

## NOTES:

1.  $C_{PD}$  is used to determine the dynamic power dissipation ( $P_D$  in  $\mu\text{W}$ )  
 $P_D = C_{PD} \times V_{CC}^2 \times f_i + \sum ((C_L + C_S) \times V_{CC}^2 \times f_o)$  where:  
 $f_i$  = input frequency in MHz;  $C_L$  = output load capacity in pF;  
 $f_o$  = output frequency in MHz;  $C_S$  = maximum switch capacitance in pF;  
 $V_{CC}$  = supply voltage in V;  
 $\sum ((C_L + C_S) \times V_{CC}^2 \times f_o)$  = sum of the outputs.
2. The condition is  $V_I = \text{GND to } V_{CC}$ .

## ORDERING INFORMATION

PACKAGES	TEMPERATURE RANGE	OUTSIDE NORTH AMERICA	NORTH AMERICA	PKG. DWG. #
16-Pin Plastic DIL	-40°C to +125°C	74LV4053 N	74LV4053 N	SOT38-1
16-Pin Plastic SO	-40°C to +125°C	74LV4053 D	74LV4053 D	SOT109-1
16-Pin Plastic SSOP Type II	-40°C to +125°C	74LV4053 DB	74LV4053 DB	SOT338-1
16-Pin Plastic TSSOP Type I	-40°C to +125°C	74LV4053 PW	74LV4053PW DH	SOT403-1

## PIN CONFIGURATION

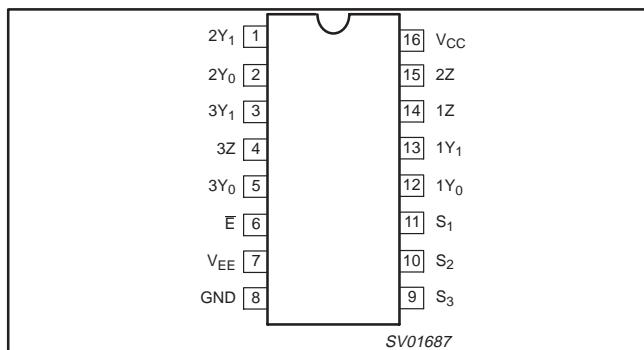

## PIN DESCRIPTION

PIN NUMBER	SYMBOL	FUNCTION
2, 1	$2Y_0, 2Y_1$	Independent inputs/outputs
5, 3	$3Y_0, 3Y_1$	Independent inputs/outputs
6	$\bar{E}$	Enable input (active LOW)
7	$V_{EE}$	Negative supply voltage
8	GND	Ground (0 V)
11, 10, 9	$S_1$ to $S_3$	Select inputs
12, 13	$1Y_0, 1Y_1$	Independent inputs/outputs
14, 15, 4	$1Z$ to $3Z$	Common inputs/outputs
16	$V_{CC}$	Positive supply voltage

# Triple 2-channel analog multiplexer/demultiplexer

# 74LV4053

## LOGIC SYMBOL

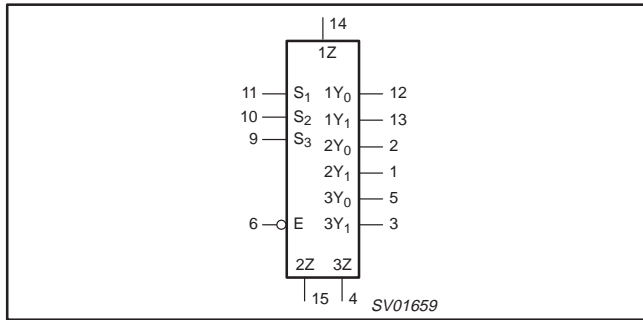

## FUNCTIONAL DIAGRAM

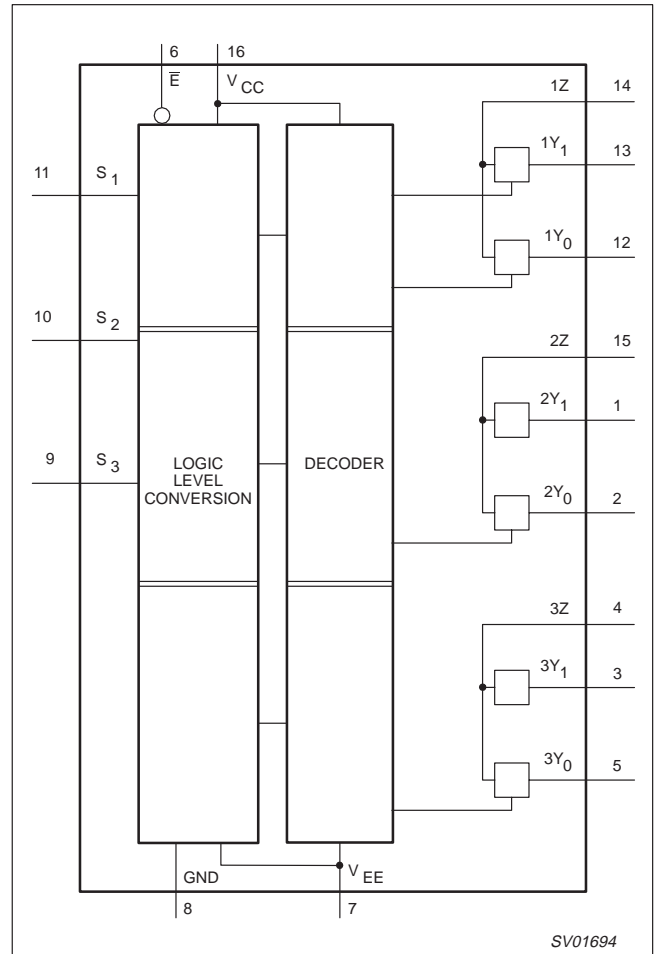

## LOGIC SYMBOL (IEEE/IEC)

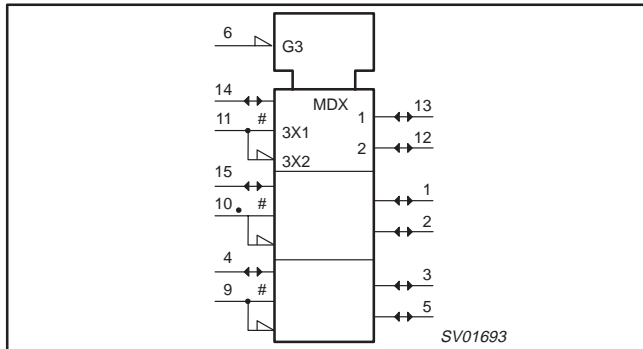

## FUNCTION TABLE

INPUTS		CHANNEL ON
$\bar{E}$	$S_n$	
L	L	$nY_0 - nZ$
L	H	$nY_1 - nZ$
H	X	None

### NOTES:

- H = HIGH voltage level
- L = LOW voltage level
- X = don't care

## SCHEMATIC DIAGRAM (ONE SWITCH)

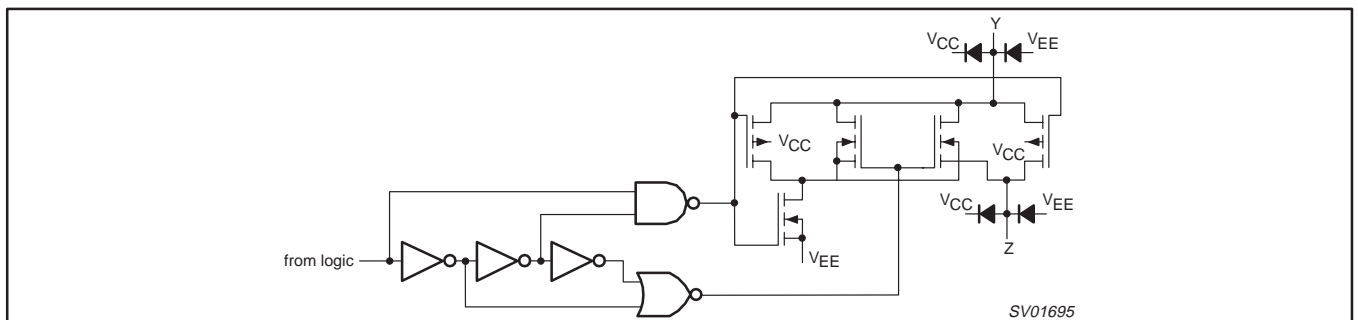

## Triple 2-channel analog multiplexer/demultiplexer

74LV4053

**ABSOLUTE MAXIMUM RATINGS<sup>1, 2</sup>**

In accordance with the Absolute Maximum Rating System (IEC 134).

Voltages are referenced to GND (ground = 0 V).

SYMBOL	PARAMETER	CONDITIONS	RATING	UNIT
$V_{CC}$	DC supply voltage		-0.5 to +7.0	V
$\pm I_{IK}$	DC input diode current	$V_I < -0.5$ or $V_I > V_{CC} + 0.5$ V	20	mA
$\pm I_{SK}$	DC switch diode current	$V_O < -0.5$ or $V_O > V_{CC} + 0.5$ V	20	mA
$\pm I_S$	DC switch current	$-0.5$ V $< V_S < V_{CC} + 0.5$ V	25	mA
$T_{stg}$	Storage temperature range		-65 to +150	°C
$P_{TOT}$	Power dissipation per package – plastic DIL – plastic mini-pack (SO) – plastic shrink mini-pack (SSOP and TSSOP)	for temperature range: -40 to +125°C above +70°C derate linearly with 12 mW/K above +70°C derate linearly with 8 mW/K above +60°C derate linearly with 5.5 mW/K	750 500 400	mW

**NOTES:**

- Stresses beyond those listed may cause permanent damage to the device. These are stress ratings only and functional operation of the device at these or any other conditions beyond those indicated under “recommended operating conditions” is not implied. Exposure to absolute-maximum-rated conditions for extended periods may affect device reliability.
- The input and output voltage ratings may be exceeded if the input and output current ratings are observed.

**RECOMMENDED OPERATING CONDITIONS**

SYMBOL	PARAMETER	CONDITIONS	MIN	TYP	MAX	UNIT
$V_{CC}$	DC supply voltage	See Note 1 and Figure 5	1.0	3.3	6.0	V
$V_I$	Input voltage		0	–	$V_{CC}$	V
$V_O$	Output voltage		0	–	$V_{CC}$	V
$T_{amb}$	Operating ambient temperature range in free air	See DC and AC characteristics	-40 -40		+85 +125	°C
$t_r, t_f$	Input rise and fall times	$V_{CC} = 1.0$ V to 2.0 V $V_{CC} = 2.0$ V to 2.7 V $V_{CC} = 2.7$ V to 6.0 V	– – –	– – –	500 200 100	ns/V

**NOTE:**

- The LV is guaranteed to function down to  $V_{CC} = 1.0$  V (input levels GND or  $V_{CC}$ ); DC characteristics are guaranteed from  $V_{CC} = 1.2$  V to  $V_{CC} = 6.0$  V.

## Triple 2-channel analog multiplexer/demultiplexer

74LV4053

**DC ELECTRICAL CHARACTERISTICS**

Over recommended operating conditions, voltages are referenced to GND (ground = 0 V)

SYMBOL	PARAMETER	TEST CONDITIONS	LIMITS					UNIT
			-40°C to +85°C			-40°C to +125°C		
			MIN	TYP <sup>1</sup>	MAX	MIN	MAX	
V <sub>IH</sub>	HIGH level Input voltage	V <sub>CC</sub> = 1.2 V	0.9			0.9		V
		V <sub>CC</sub> = 2.0 V	1.4			1.4		
		V <sub>CC</sub> = 2.7 to 3.6 V	2.0			2.0		
		V <sub>CC</sub> = 4.5 V	3.15			3.15		
		V <sub>CC</sub> = 6.0 V	4.20			4.20		
V <sub>IL</sub>	LOW level Input voltage	V <sub>CC</sub> = 1.2 V			0.3		0.3	V
		V <sub>CC</sub> = 2.0 V			0.6		0.6	
		V <sub>CC</sub> = 2.7 to 3.6 V			0.8		0.8	
		V <sub>CC</sub> = 4.5 V			1.35		1.35	
		V <sub>CC</sub> = 6.0 V			1.80		1.80	
±I <sub>I</sub>	Input leakage current	V <sub>CC</sub> = 3.6 V	V <sub>I</sub> = V <sub>CC</sub> or GND		1.0		1.0	μA
		V <sub>CC</sub> = 6.0 V			2.0		2.0	
±I <sub>S</sub>	Analog switch OFF-state current per channel	V <sub>CC</sub> = 3.6 V	V <sub>I</sub> = V <sub>IH</sub> or V <sub>IL</sub>  V <sub>SI</sub>   = V <sub>CC</sub> - GND (See Figure 2)		1.0		1.0	μA
		V <sub>CC</sub> = 6.0 V			2.0		2.0	
±I <sub>S</sub>	Analog switch ON-state current	V <sub>CC</sub> = 3.6 V	V <sub>I</sub> = V <sub>IH</sub> or V <sub>IL</sub> V <sub>SI</sub> = V <sub>CC</sub> - GND (See Figure 3)		1.0		1.0	μA
		V <sub>CC</sub> = 6.0 V			2.0		2.0	
I <sub>CC</sub>	Quiescent supply current	V <sub>CC</sub> = 3.6 V	V <sub>I</sub> = V <sub>CC</sub> or GND V <sub>IS</sub> = GND or V <sub>CC</sub> ; V <sub>OS</sub> = V <sub>CC</sub> or GND		20.0		40	μA
		V <sub>CC</sub> = 6.0 V			40.0		80	
ΔI <sub>CC</sub>	Additional quiescent supply current per input	V <sub>CC</sub> = 2.7 to 3.6 V	V <sub>I</sub> = V <sub>CC</sub> - 0.6 V		500		850	μA
R <sub>ON</sub>	ON-resistance (peak)	V <sub>CC</sub> = 1.2 V	I <sub>S</sub> = 100 μA; V <sub>IS</sub> = V <sub>CC</sub> to GND; V <sub>I</sub> = V <sub>IH</sub> or V <sub>IL</sub>					Ω
		V <sub>CC</sub> = 2.0 V	I <sub>S</sub> = 1000 μA; V <sub>IS</sub> = V <sub>CC</sub> to GND; V <sub>I</sub> = V <sub>IH</sub> or V <sub>IL</sub>		180	365	435	
		V <sub>CC</sub> = 2.7 V			115	225	270	
		V <sub>CC</sub> = 3.0 to 3.6 V			100	200	245	
		V <sub>CC</sub> = 4.5 V			75	150	180	
V <sub>CC</sub> = 6.0 V		70		140	165			
R <sub>ON</sub>	ON-resistance (rail)	V <sub>CC</sub> = 1.2 V	I <sub>S</sub> = 100 μA; V <sub>IS</sub> = GND; V <sub>I</sub> = V <sub>IH</sub> or V <sub>IL</sub>		250			Ω
		V <sub>CC</sub> = 2.0 V	I <sub>S</sub> = 1000 μA; V <sub>IS</sub> = GND; V <sub>I</sub> = V <sub>IH</sub> or V <sub>IL</sub>		120	280	325	
		V <sub>CC</sub> = 2.7 V			75	170	195	
		V <sub>CC</sub> = 3.0 to 3.6 V			70	155	180	
		V <sub>CC</sub> = 4.5 V			50	120	135	
V <sub>CC</sub> = 6.0 V		45		105	120			
R <sub>ON</sub>	ON-resistance (rail)	V <sub>CC</sub> = 1.2 V	V <sub>I</sub> = V <sub>IH</sub> or V <sub>IL</sub> ; I <sub>S</sub> = 100 μA; V <sub>IS</sub> = V <sub>CC</sub>		350			Ω
		V <sub>CC</sub> = 2.0 V	V <sub>I</sub> = V <sub>IH</sub> or V <sub>IL</sub> ; I <sub>S</sub> = 1000 μA; V <sub>IS</sub> = V <sub>CC</sub>		170	340	400	
		V <sub>CC</sub> = 2.7 V			105	210	250	
		V <sub>CC</sub> = 3.0 to 3.6 V			95	190	225	
		V <sub>CC</sub> = 4.5 V			70	140	165	
V <sub>CC</sub> = 6.0 V		65		125	150			

# Triple 2-channel analog multiplexer/demultiplexer

# 74LV4053

## DC ELECTRICAL CHARACTERISTICS (Continued)

SYMBOL	PARAMETER	TEST CONDITIONS	LIMITS					UNIT		
			-40°C to +85°C			-40°C to +125°C				
			MIN	TYP <sup>1</sup>	MAX	MIN	MAX			
$\Delta R_{ON}$	Maximum variation of ON-resistance between any two channels	$V_{CC} = 1.2\text{ V}$ $V_{CC} = 2.0\text{ V}$ $V_{CC} = 2.7\text{ V}$ $V_{CC} = 3.0\text{ to }3.6\text{ V}$ $V_{CC} = 4.5\text{ V}$ $V_{CC} = 6.0\text{ V}$	$V_I = V_{IH}\text{ or }V_{IL};$ $V_{IS} = V_{CC}\text{ to GND}$							$\Omega$
				5						
				4						
				4						
				3						
				2						

**NOTES:**

- All typical values are measured at  $T_{amb} = 25^\circ\text{C}$ .
- At supply voltages approaching 1.2 V, the analog switch ON-resistance becomes extremely non-linear. Therefore, it is recommended that these devices be used to transmit digital signals only, when using these supply voltages.

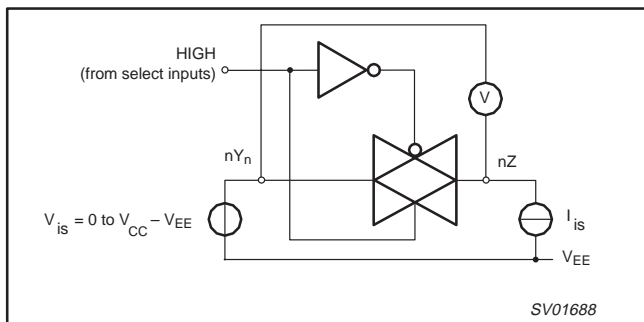

Figure 1. Test circuit for measuring ON-resistance ( $R_{ON}$ ).

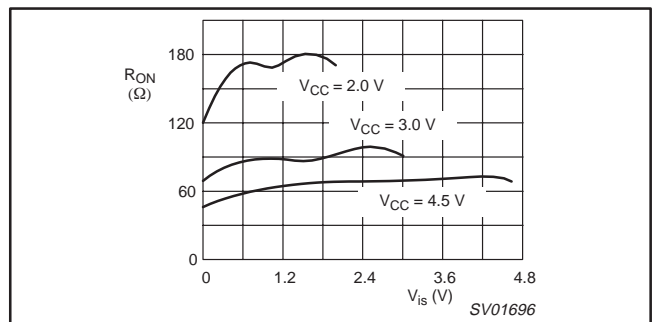

Figure 4. Typical ON-resistance ( $R_{on}$ ) as a function of input voltage ( $V_{is}$ ) for  $V_{is} = 0$  to  $V_{CC} - V_{EE}$ .

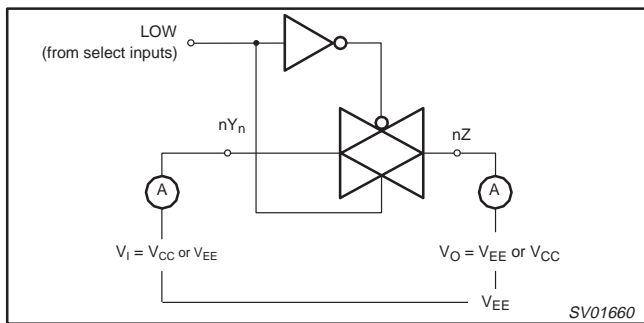

Figure 2. Test circuit for measuring OFF-state current.

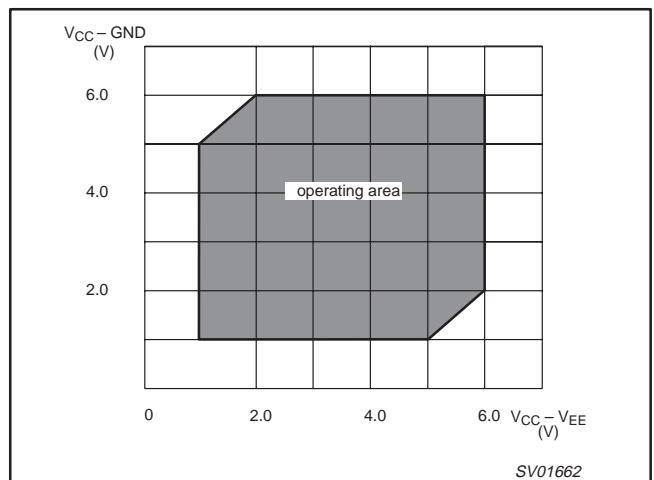

Figure 5. Guaranteed operating area as a function of the supply voltages.

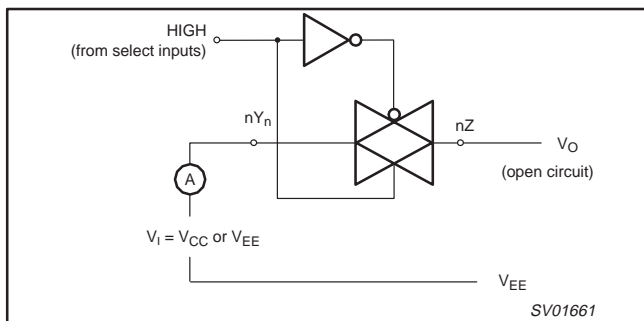

Figure 3. Test circuit for measuring ON-state current.

Triple 2-channel analog multiplexer/demultiplexer

74LV4053

**AC CHARACTERISTICS**

GND = 0 V;  $t_r = t_f \leq 2.5\text{ns}$ ;  $C_L = 50\text{pF}$

SYMBOL	PARAMETER	CONDITION		LIMITS					UNIT
				-40 to +85 °C			-40 to +125 °C		
		$V_{CC}$ (V)	OTHER	MIN	TYP <sup>1</sup>	MAX	MIN	MAX	
$t_{PHL}/t_{PLH}$	Propagation delay $V_{is}$ to $V_{os}$	1.2	$R_L = \infty$ ; $C_L = 50\text{ pF}$ Figure 12		25				ns
		2.0			9	17		20	
		2.7			6	13		15	
		3.0 to 3.6			5 <sup>2</sup>	10		12	
		4.5			4	9		10	
		6.0			3	7		8	
$t_{PZH}/t_{PZL}$	Turn-on time $\bar{E}$ to $V_{os}$	1.2	$R_L = 1\text{ k}\Omega$ ; $C_L = 50\text{ pF}$ Figures 13 and 1		100				ns
		2.0			34	65		77	
		2.7			25	48		56	
		3.0 to 3.6			19 <sup>2</sup>	38		45	
		4.5			17	32		38	
		6.0			13	25		29	
$t_{PZH}/t_{PZL}$	Turn-on time $S_n$ to $V_{os}$	1.2	$R_L = 1\text{ k}\Omega$ $C_L = 50\text{ pF}$ Figures 13 and 1		125				ns
		2.0			43	82		97	
		2.7			31	60		71	
		3.0 to 3.6			24 <sup>2</sup>	48		57	
		4.5			21	41		48	
		6.0			16	31		37	
$t_{PHZ}/t_{PLZ}$	Turn-off time $\bar{E}$ to $V_{os}$	1.2	$R_L = 1\text{ k}\Omega$ $C_L = 50\text{ pF}$ Figures 13 and 1		95				ns
		2.0			34	61		73	
		2.7			26	46		54	
		3.0 to 3.6			20 <sup>2</sup>	37		44	
		4.5			18	32		38	
		6.0			15	25		30	
$t_{PHZ}/t_{PLZ}$	Turn-off time $S_n$ to $V_{os}$	1.2	$R_L = 1\text{ k}\Omega$ $C_L = 50\text{ pF}$ Figures 13 and 1		90				ns
		2.0			32	59		70	
		2.7			24	44		52	
		3.0 to 3.6			19 <sup>2</sup>	36		42	
		4.5			17	31		36	
		6.0			14	24		28	

**NOTES:**

1. Unless otherwise stated, all typical values are measured at  $T_{amb} = 25^\circ\text{C}$
2. Typical values are measured at  $V_{CC} = 3.3\text{ V}$ .

# Triple 2-channel analog multiplexer/demultiplexer

74LV4053

## ADDITIONAL AC CHARACTERISTICS

Recommended conditions and typical values

GND = 0 V;  $t_r = t_f \leq 2.5\text{ns}$

SYMBOL	PARAMETER	TYP.	UNIT	V <sub>CC</sub> (V)	V <sub>is(p-p)</sub> (V)	CONDITIONS
	Sine-wave distortion f = 1 kHz	0.80 0.40	%	3.0 6.0	2.75 5.50	R <sub>L</sub> = 10 kΩ; C <sub>L</sub> = 50 pf Figures 9 and 10
	Sine-wave distortion f = 10 kHz	2.40 1.20	%	3.0 6.0	2.75 5.50	R <sub>L</sub> = 10 kΩ; C <sub>L</sub> = 50 pf Figures 9 and 10
	Switch "OFF" signal feed through	-50 -50	dB	3.0 6.0	Note 1	R <sub>L</sub> = 600 Ω; C <sub>L</sub> = 50 pf; f = 1 MHz Figures 5 and 11
	Crosstalk between any two switches/multiplexers	-60 -60	dB	3.0 6.0	Note 1	R <sub>L</sub> = 600 Ω; C <sub>L</sub> = 50 pf; f = 1 MHz Figure 8
V <sub>(p-p)</sub>	Crosstalk voltage between enable or address input to any switch (peak-to-peak value)	110 120	mV	3.0 6.0		R <sub>L</sub> = 600 Ω; C <sub>L</sub> = 50 pf; f = 1 MHz (S <sub>n</sub> or $\bar{E}$ , square wave between V <sub>CC</sub> and GND t <sub>r</sub> = t <sub>f</sub> = 6 ns) Figure 8
f <sub>max</sub>	Minimum frequency response (-3 dB)	180 200	MHz	3.0 6.0	Note 2	R <sub>L</sub> = 50 Ω; C <sub>L</sub> = 50 pF Figures 6, 8 and 9
C <sub>S</sub>	Maximum switch capacitance	5	pf			

**GENERAL NOTES:**

V<sub>is</sub> is the input voltage at nY<sub>n</sub> or nZ terminal, whichever is assigned as an input.

V<sub>os</sub> is the output voltage at nY<sub>n</sub> or nZ terminal, whichever is assigned as an output.

**NOTES:**

- Adjust input voltage V<sub>is</sub> is 0 dBm level (0 dBm = 1 mW into 600 Ω).
- Adjust input voltage V<sub>is</sub> is 0 dBm level at V<sub>os</sub> for 1 MHz (0 dBm = 1 mW into 50 Ω).

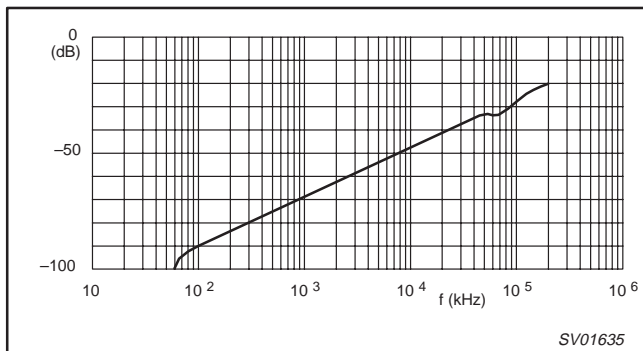

Figure 6. Typical switch "OFF" signal feed-through as a function of frequency.

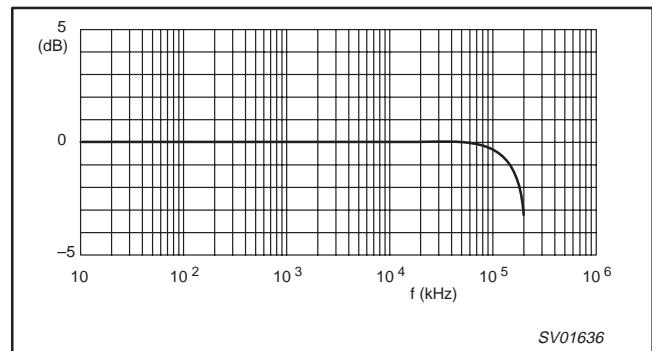

Figure 7. Typical frequency response.

**NOTES TO FIGURES 6 AND 7:**

Test conditions: V<sub>CC</sub> = 3.0 V; GND = 0 V; V<sub>EE</sub> = -3.0V; R<sub>L</sub> = 50 Ω; R<sub>SOURCE</sub> = 1kΩ.

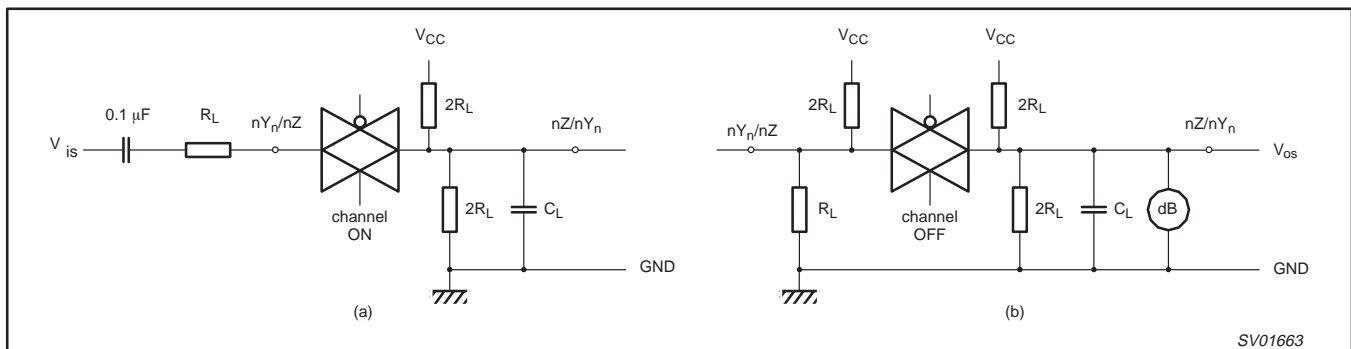

Figure 8. Test circuit for measuring crosstalk between any two switches. (a) channel ON condition; (b) channel OFF condition.

# Triple 2-channel analog multiplexer/demultiplexer

# 74LV4053

**NOTE TO FIGURE 8:**

The crosstalk is defined as follows (oscilloscope output):

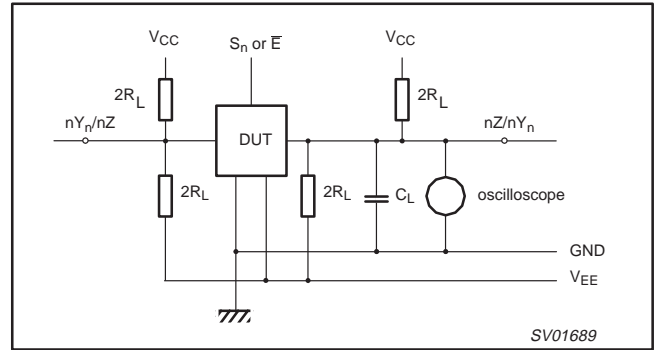
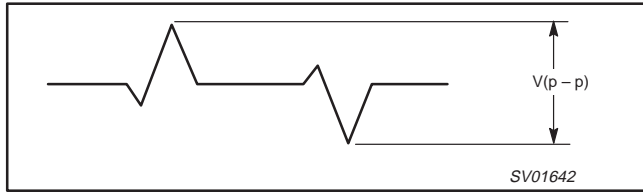

**Figure 9. Test circuit for measuring crosstalk between control and any switch.**

**NOTE TO FIGURE 9:**

Adjust input voltage to obtain 0 dBm at  $V_{OS}$  when  $F_{in} = 1$  MHz. After set-up frequency of  $f_{in}$  is increased to obtain a reading of -3 dB at  $V_{OS}$ .

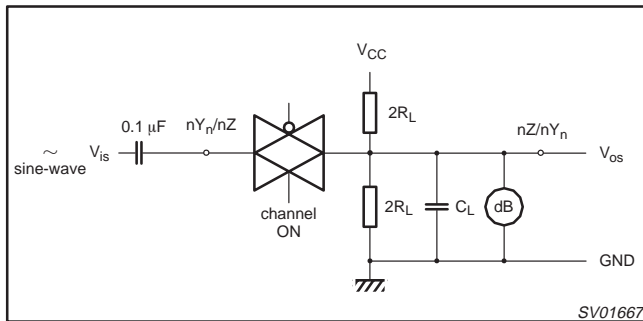

**Figure 10. Test circuit for measuring minimum frequency response.**

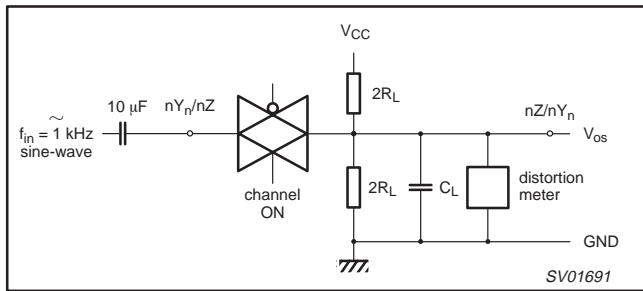

**Figure 11. Test circuit for measuring sine-wave distortion.**

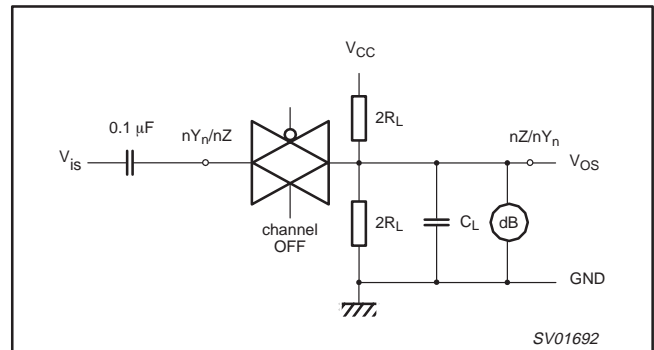

**Figure 12. Test circuit for measuring switch "OFF" signal feed-through.**

# Triple 2-channel analog multiplexer/demultiplexer

# 74LV4053

## WAVEFORMS

$V_M = 1.5\text{ V}$  at  $2.7\text{ V} \leq V_{CC} \leq 3.6\text{ V}$   
 $V_M = 0.5 \times V_{CC}$  at  $2.7\text{ V} > V_{CC} > 3.6\text{ V}$   
 $V_{OL}$  and  $V_{OH}$  are the typical output voltage drop that occur with the output load  
 $V_X = V_{OL} + 0.3\text{ V}$  at  $2.7\text{ V} \leq V_{CC} \leq 3.6\text{ V}$   
 $V_X = V_{OL} + 0.1 \times V_{CC}$  at  $2.7\text{ V} > V_{CC} > 3.6\text{ V}$   
 $V_Y = V_{OH} - 0.3\text{ V}$  at  $2.7\text{ V} \leq V_{CC} \leq 3.6\text{ V}$   
 $V_Y = V_{OH} - 0.1 \times V_{CC}$  at  $2.7\text{ V} > V_{CC} > 3.6\text{ V}$

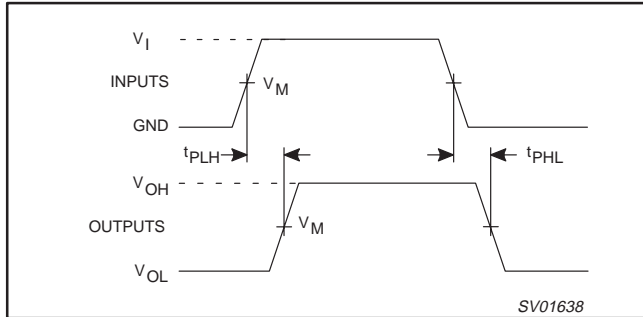

Figure 13. Input ( $V_{IS}$ ) to output ( $V_{OS}$ ) propagation delays.

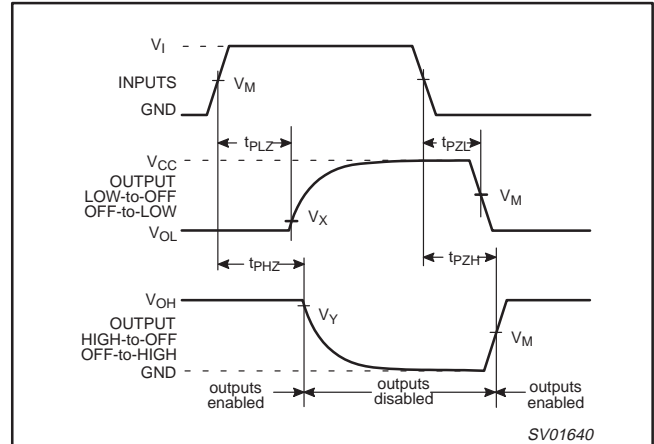

Figure 14. Turn-on and turn-off times for the inputs ( $S_n, \bar{E}$ ) to the output ( $V_{OS}$ ).

## TEST CIRCUIT

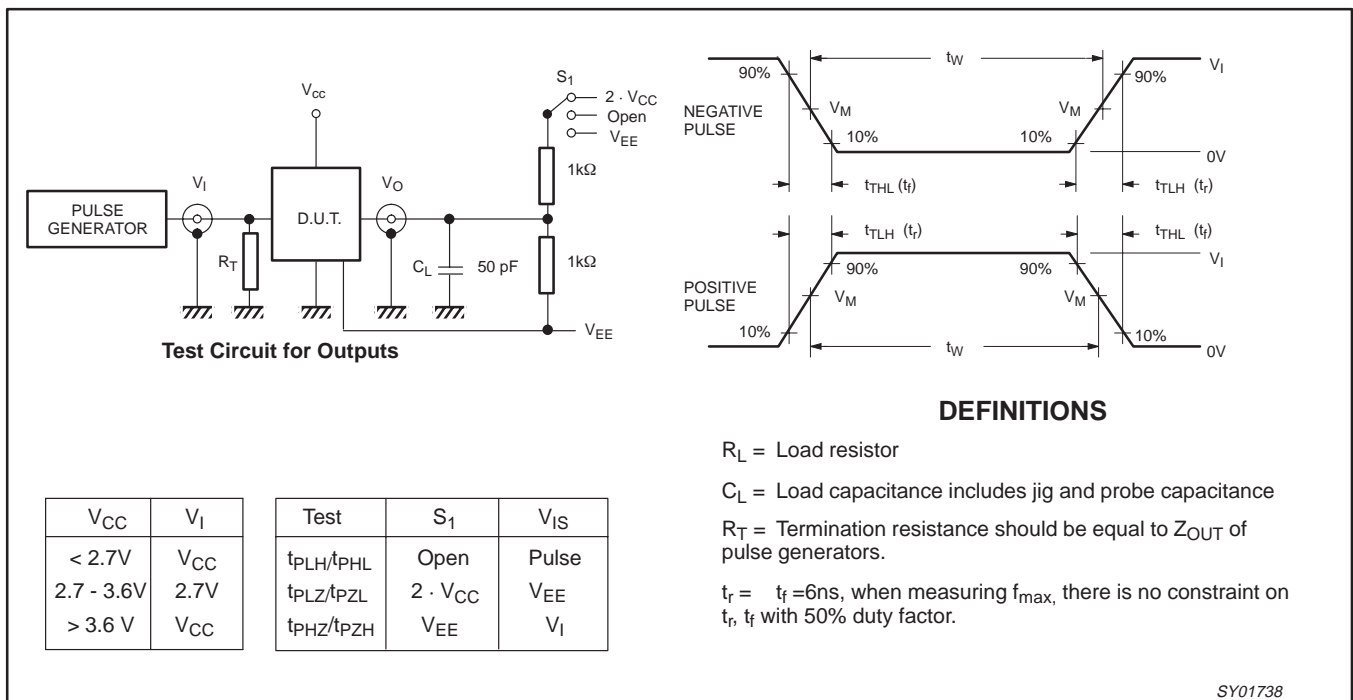

Figure 15. Load circuitry for switching times.

# Triple 2-channel analog multiplexer/demultiplexer

## 74LV4053

DIP16: plastic dual in-line package; 16 leads (300 mil)

SOT38-4

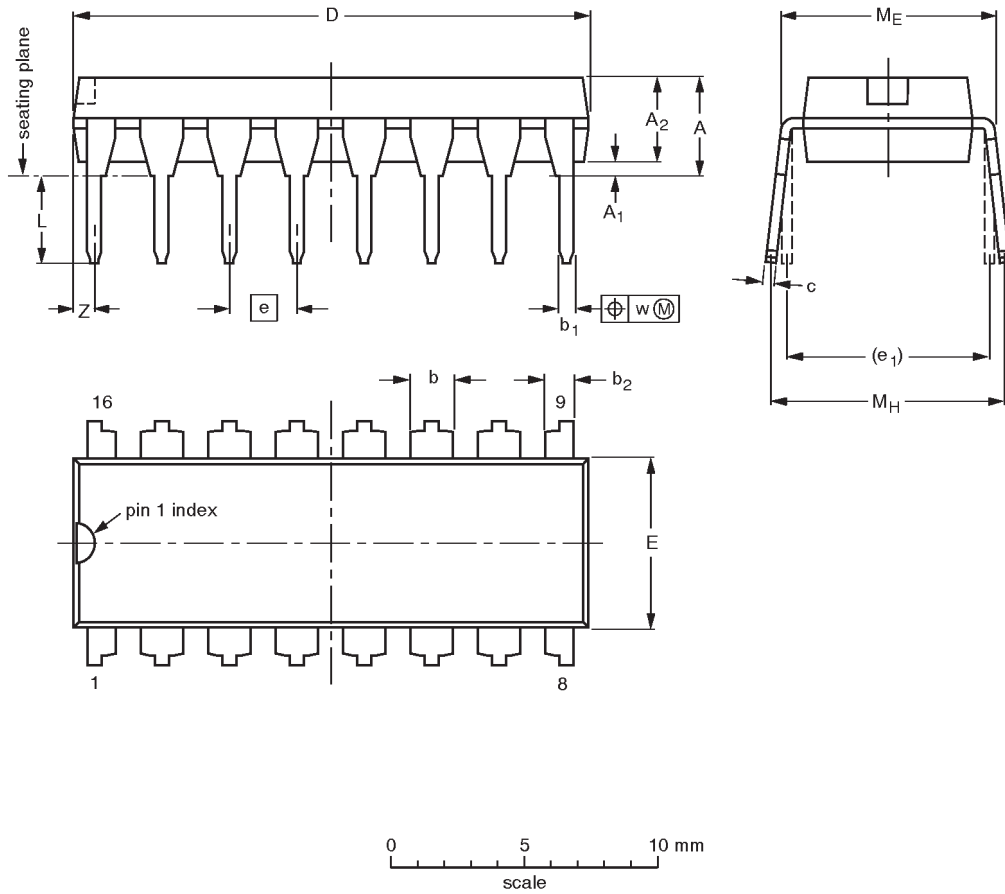

**DIMENSIONS (inch dimensions are derived from the original mm dimensions)**

UNIT	A max.	A <sub>1</sub> min.	A <sub>2</sub> max.	b	b <sub>1</sub>	b <sub>2</sub>	c	D <sup>(1)</sup>	E <sup>(1)</sup>	e	e <sub>1</sub>	L	M <sub>E</sub>	M <sub>H</sub>	w	Z <sup>(1)</sup> max.
mm	4.2	0.51	3.2	1.73 1.30	0.53 0.38	1.25 0.85	0.36 0.23	19.50 18.55	6.48 6.20	2.54	7.62	3.60 3.05	8.25 7.80	10.0 8.3	0.254	0.76
inches	0.17	0.020	0.13	0.068 0.051	0.021 0.015	0.049 0.033	0.014 0.009	0.77 0.73	0.26 0.24	0.10	0.30	0.14 0.12	0.32 0.31	0.39 0.33	0.01	0.030

**Note**

1. Plastic or metal protrusions of 0.25 mm maximum per side are not included.

OUTLINE VERSION	REFERENCES				EUROPEAN PROJECTION	ISSUE DATE
	IEC	JEDEC	EIAJ			
SOT38-4						92-11-17 95-01-14

# Triple 2-channel analog multiplexer/demultiplexer

# 74LV4053

**SO16: plastic small outline package; 16 leads; body width 3.9 mm**

**SOT109-1**

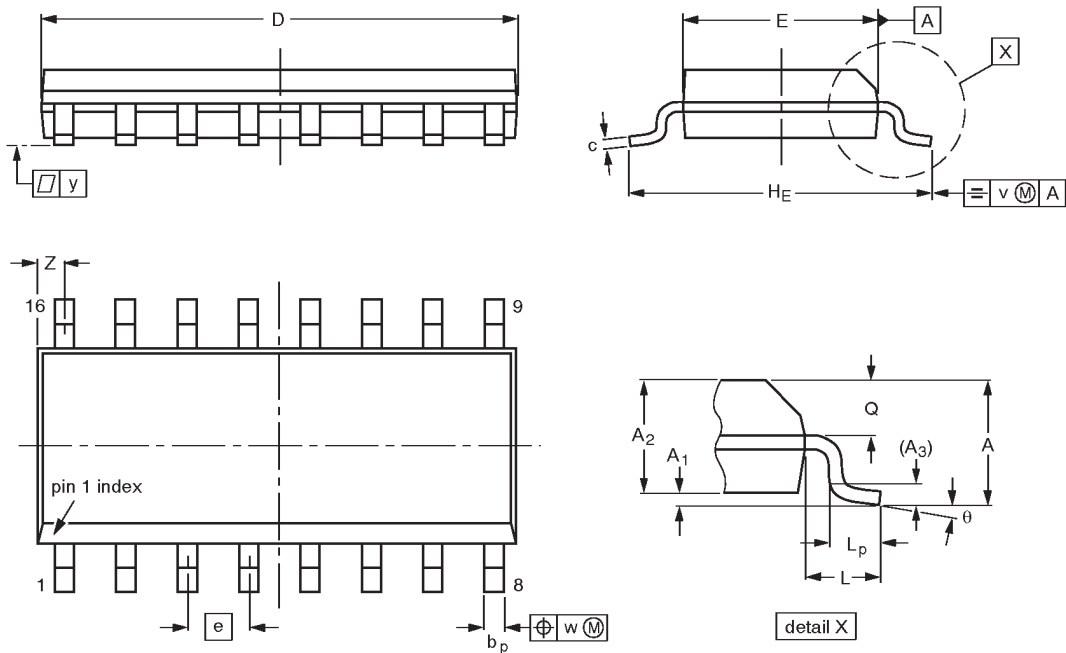

**DIMENSIONS (inch dimensions are derived from the original mm dimensions)**

UNIT	A max.	A <sub>1</sub>	A <sub>2</sub>	A <sub>3</sub>	b <sub>p</sub>	c	D <sup>(1)</sup>	E <sup>(1)</sup>	e	H <sub>E</sub>	L	L <sub>p</sub>	Q	v	w	y	z <sup>(1)</sup>	θ
mm	1.75	0.25 0.10	1.45 1.25	0.25	0.49 0.36	0.25 0.19	10.0 9.8	4.0 3.8	1.27	6.2 5.8	1.05	1.0 0.4	0.7 0.6	0.25	0.25	0.1	0.7 0.3	8° 0°
inches	0.069	0.0098 0.0039	0.057 0.049	0.01	0.019 0.014	0.0098 0.0075	0.39 0.38	0.16 0.15	0.050	0.24 0.23	0.041	0.039 0.016	0.028 0.020	0.01	0.01	0.004	0.028 0.012	

**Note**

1. Plastic or metal protrusions of 0.15 mm maximum per side are not included.

OUTLINE VERSION	REFERENCES				EUROPEAN PROJECTION	ISSUE DATE
	IEC	JEDEC	EIAJ			
SOT109-1	076E07S	MS-012AC				91-08-13 95-01-23

Triple 2-channel analog multiplexer/demultiplexer

74LV4053

SSOP16: plastic shrink small outline package; 16 leads; body width 5.3 mm

SOT338-1

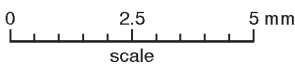
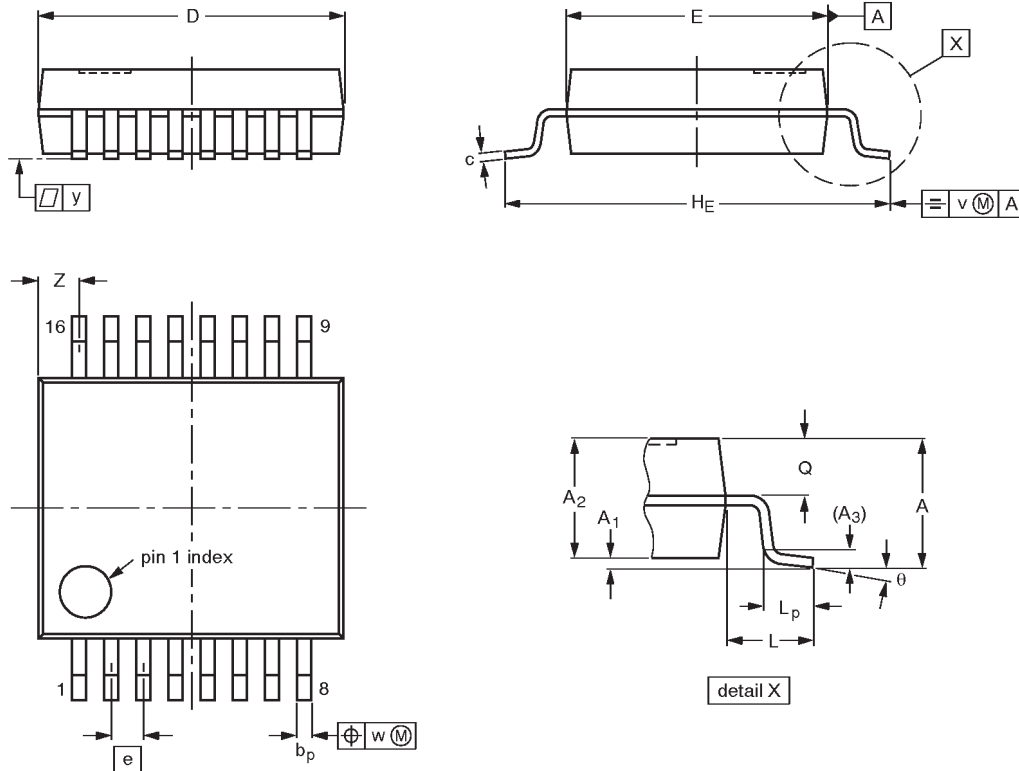

DIMENSIONS (mm are the original dimensions)

UNIT	A max.	A <sub>1</sub>	A <sub>2</sub>	A <sub>3</sub>	b <sub>p</sub>	c	D <sup>(1)</sup>	E <sup>(1)</sup>	e	H <sub>E</sub>	L	L <sub>p</sub>	Q	v	w	y	Z <sup>(1)</sup>	θ
mm	2.0	0.21 0.05	1.80 1.65	0.25	0.38 0.25	0.20 0.09	6.4 6.0	5.4 5.2	0.65	7.9 7.6	1.25	1.03 0.63	0.9 0.7	0.2	0.13	0.1	1.00 0.55	8° 0°

Note

1. Plastic or metal protrusions of 0.25 mm maximum per side are not included.

OUTLINE VERSION	REFERENCES				EUROPEAN PROJECTION	ISSUE DATE
	IEC	JEDEC	EIAJ			
SOT338-1		MO-150AC				94-01-14- 95-02-04

Triple 2-channel analog multiplexer/demultiplexer

74LV4053

TSSOP16: plastic thin shrink small outline package; 16 leads; body width 4.4 mm

SOT403-1

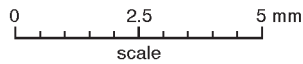
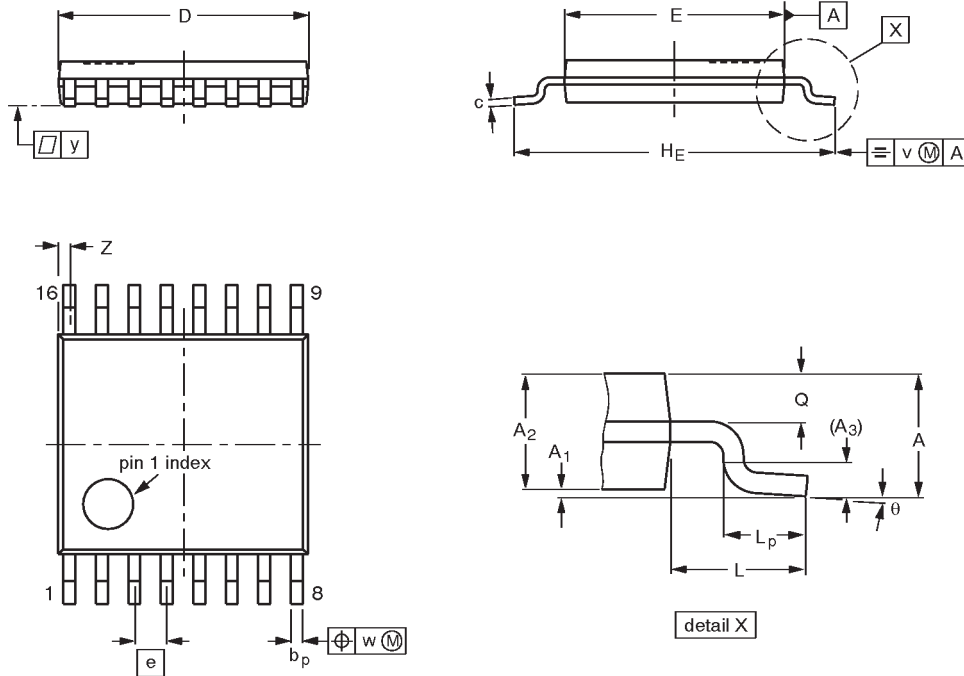

DIMENSIONS (mm are the original dimensions)

UNIT	A max.	A <sub>1</sub>	A <sub>2</sub>	A <sub>3</sub>	b <sub>p</sub>	c	D <sup>(1)</sup>	E <sup>(2)</sup>	e	H <sub>E</sub>	L	L <sub>p</sub>	Q	v	w	y	Z <sup>(1)</sup>	θ
mm	1.10	0.15 0.05	0.95 0.80	0.25	0.30 0.19	0.2 0.1	5.1 4.9	4.5 4.3	0.65	6.6 6.2	1.0	0.75 0.50	0.4 0.3	0.2	0.13	0.1	0.40 0.06	8° 0°

Notes

1. Plastic or metal protrusions of 0.15 mm maximum per side are not included.
2. Plastic interlead protrusions of 0.25 mm maximum per side are not included.

OUTLINE VERSION	REFERENCES				EUROPEAN PROJECTION	ISSUE DATE
	IEC	JEDEC	EIAJ			
SOT403-1		MO-153				94-07-12 95-04-04

---

Triple 2-channel analog multiplexer/demultiplexer

74LV4053

---

**NOTES**

## Triple 2-channel analog multiplexer/demultiplexer

74LV4053

## DEFINITIONS

Data Sheet Identification	Product Status	Definition
<i>Objective Specification</i>	<b>Formative or in Design</b>	This data sheet contains the design target or goal specifications for product development. Specifications may change in any manner without notice.
<i>Preliminary Specification</i>	<b>Preproduction Product</b>	This data sheet contains preliminary data, and supplementary data will be published at a later date. Philips Semiconductors reserves the right to make changes at any time without notice in order to improve design and supply the best possible product.
<i>Product Specification</i>	<b>Full Production</b>	This data sheet contains Final Specifications. Philips Semiconductors reserves the right to make changes at any time without notice, in order to improve design and supply the best possible product.

Philips Semiconductors and Philips Electronics North America Corporation reserve the right to make changes, without notice, in the products, including circuits, standard cells, and/or software, described or contained herein in order to improve design and/or performance. Philips Semiconductors assumes no responsibility or liability for the use of any of these products, conveys no license or title under any patent, copyright, or mask work right to these products, and makes no representations or warranties that these products are free from patent, copyright, or mask work right infringement, unless otherwise specified. Applications that are described herein for any of these products are for illustrative purposes only. Philips Semiconductors makes no representation or warranty that such applications will be suitable for the specified use without further testing or modification.

## LIFE SUPPORT APPLICATIONS

Philips Semiconductors and Philips Electronics North America Corporation Products are not designed for use in life support appliances, devices, or systems where malfunction of a Philips Semiconductors and Philips Electronics North America Corporation Product can reasonably be expected to result in a personal injury. Philips Semiconductors and Philips Electronics North America Corporation customers using or selling Philips Semiconductors and Philips Electronics North America Corporation Products for use in such applications do so at their own risk and agree to fully indemnify Philips Semiconductors and Philips Electronics North America Corporation for any damages resulting from such improper use or sale.

**Philips Semiconductors**  
**811 East Arques Avenue**  
**P.O. Box 3409**  
**Sunnyvale, California 94088-3409**  
**Telephone 800-234-7381**

© Copyright Philips Electronics North America Corporation 1998  
 All rights reserved. Printed in U.S.A.

print code

Date of release: 05-96

Document order number:

9397-750-04462

*Let's make things better.*



LittleDiode supplies new, hard to find or obsolete electronic components and semiconductors all over the world.

With over two million different components listed you are sure to find the part you need.

Feel free to visit us today at our online store:

[LittleDiode.com](http://LittleDiode.com)

Looking forward to providing you with the best possible service.