

DATA SHEET

74LV4094

8-stage shift-and-store bus register

Product specification

1998 Jun 23

8-stage shift-and-store bus register

74LV4094

FEATURES

- Optimized for low voltage applications: 1.0 to 3.6 V
- Accepts TTL input levels between $V_{CC} = 2.7$ V and $V_{CC} = 3.6$ V
- Typical V_{OLP} (output ground bounce) < 0.8 V at $V_{CC} = 3.3$ V, $T_{amb} = 25^{\circ}\text{C}$
- Typical V_{OHV} (output V_{OH} undershoot) > 2 V at $V_{CC} = 3.3$ V, $T_{amb} = 25^{\circ}\text{C}$
- Output capability: standard
- I_{CC} category: MSI

Applications:

- Serial-to-parallel data conversion
- Remote control holding register

DESCRIPTION

The 74LV4094 is a low-voltage Si-gate CMOS device and is pin and function compatible with 74HC/HCT4094.

The 74LV4094 is an 8-stage serial shift register having a storage latch associated with each stage for strobing data from the serial input (D) to the parallel buffered 3-State outputs (QP₀ to OP₇). The parallel outputs may be connected directly to the common bus lines. Data is shifted on the positive-going clock (CP) transitions. The data in each shift register is transferred to the storage register when the strobe input (STR) is HIGH. Data in the storage register appears at the outputs whenever the output enable input (OE) signal is HIGH. Two serial outputs (QS₁ and QS₂) are available for cascading a number of 74LV4094 devices. Data is available at QS₁ on the positive-going clock edges to allow high-speed operation in cascaded systems in which the clock rise time is fast. The same serial information is available at QS₂ on the next negative going clock edge and is for cascading 74LV4094 devices when the clock rise time is slow.

QUICK REFERENCE DATA

GND = 0 V; $T_{amb} = 25^{\circ}\text{C}$; $t_r = t_f \leq 2.5$ ns

SYMBOL	PARAMETER	CONDITIONS	TYPICAL	UNIT
t_{PHL}/t_{PLH}	Propagation delay CP to QS ₁ CP to QS ₂ CP to QP _n STR to QP _n	$C_L = 15$ pF; $V_{CC} = 3.3$ V	14	ns
			13	
			18	
			17	
f_{MAX}	Maximum clock frequency		95	MHz
C_I	Input capacitance		3.5	pF
C_{PD}	Power dissipation capacitance per gate	$V_{CC} = 3.3$ V $V_I = \text{GND to } V_{CC}$ NO TAG	83	pF

NOTE:

1. C_{PD} is used to determine the dynamic power dissipation (P_D in μW)
 $P_D = C_{PD} \times V_{CC}^2 \times f_i + \sum (C_L \times V_{CC}^2 \times f_o)$ where:
 f_i = input frequency in MHz; C_L = output load capacity in pF;
 f_o = output frequency in MHz; V_{CC} = supply voltage in V;
 $\sum (C_L \times V_{CC}^2 \times f_o)$ = sum of the outputs.

ORDERING INFORMATION

PACKAGES	TEMPERATURE RANGE	OUTSIDE NORTH AMERICA	NORTH AMERICA	PKG. DWG. #
16-Pin Plastic DIL	-40°C to +125°C	74LV4094 N	74LV4094 N	SOT38-4
16-Pin Plastic SO	-40°C to +125°C	74LV4094 D	74LV4094 D	SOT109-1

PIN CONFIGURATION

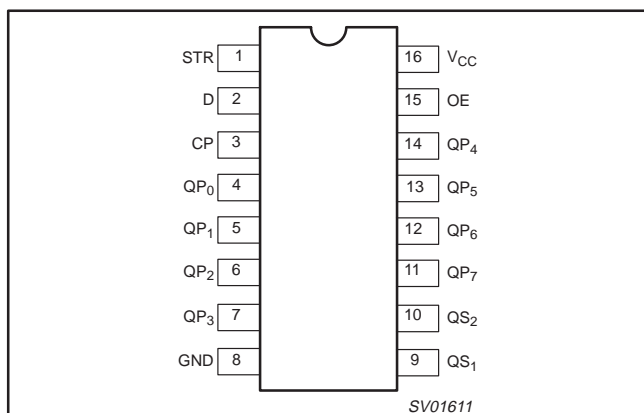

PIN DESCRIPTION

PIN NUMBER	SYMBOL	FUNCTION
1	STR	Strobe input
2	D	Serial input
3	CP	Clock input
4, 5, 6, 7, 14, 13, 12, 11	QP ₀ to QP ₇	Parallel outputs
8	GND	Ground (0 V)
9, 10	QS ₁ , QS ₂	Serial outputs
15	OE	Output enable input
16	V_{CC}	Positive supply voltage

8-stage shift-and-store bus register

74LV4094

LOGIC SYMBOL

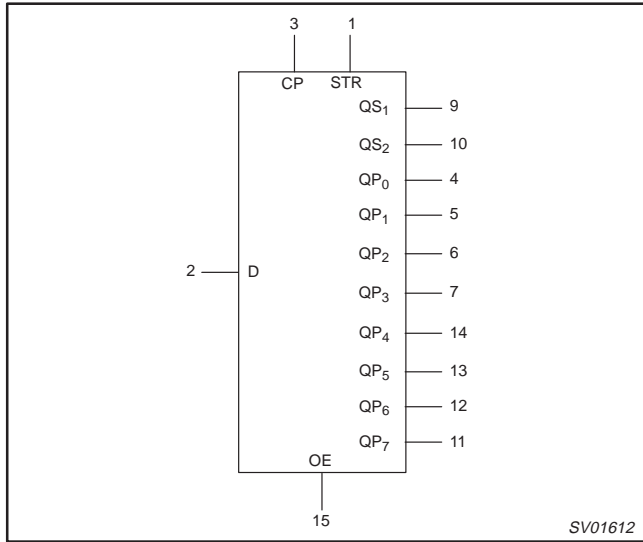

LOGIC SYMBOL (IEEE/IEC)

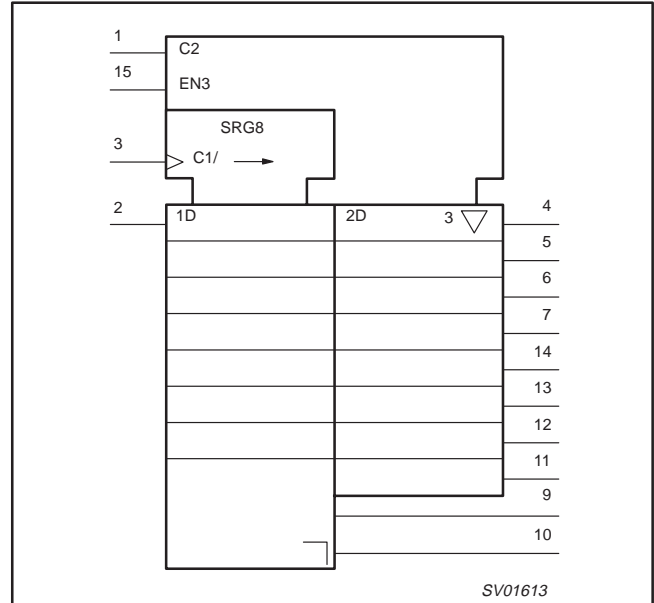

FUNCTIONAL DIAGRAM

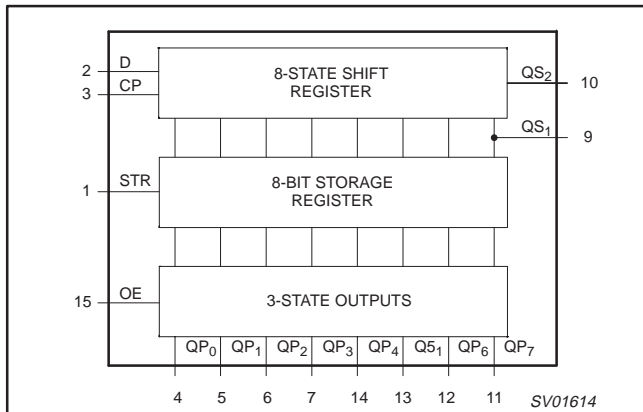

LOGIC DIAGRAM

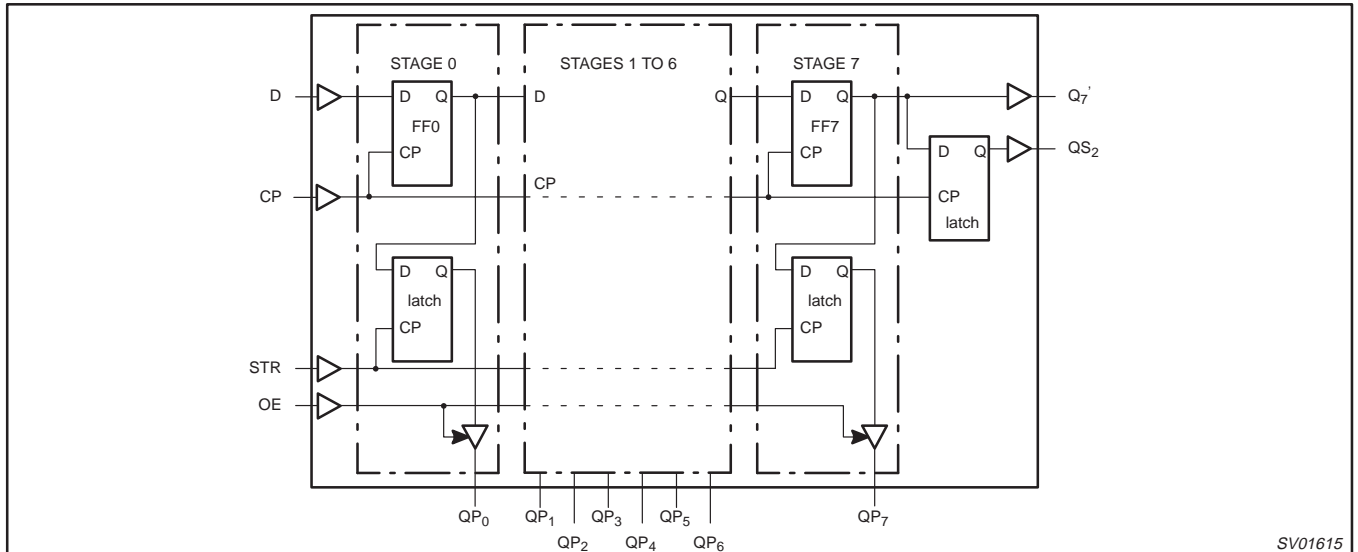

8-stage shift-and-store bus register

74LV4094

FUNCTION TABLE

INPUTS				PARALLEL OUTPUT		SERIAL OUTPUTS	
CP	OE	STR	D	QP ₀	QP _n	QS ₁	QS ₂
↑	L	X	X	Z	Z	Q' ₆	NC
↓	L	X	X	Z	Z	NC	QP ₇
↑	H	L	X	NC	NC	Q' ₆	NC
↑	H	H	L	L	QP _{n-1}	Q' ₆	NC
↑	H	H	H	H	QP _{n-1}	Q' ₆	NC
↓	H	H	H	NC	NC	NC	QP ₇

NOTES:

H = HIGH voltage level
 L = LOW voltage level
 X = don't care
 Z = high impedance OFF-state
 NC = no change

↑ = LOW-to-HIGH CP transition
 ↓ = HIGH-to-LOW CP transition
 Q'₆ = the information in the 8th register stage is transferred to the 8th register stage and QS_n clock edge.

TIMING DIAGRAM

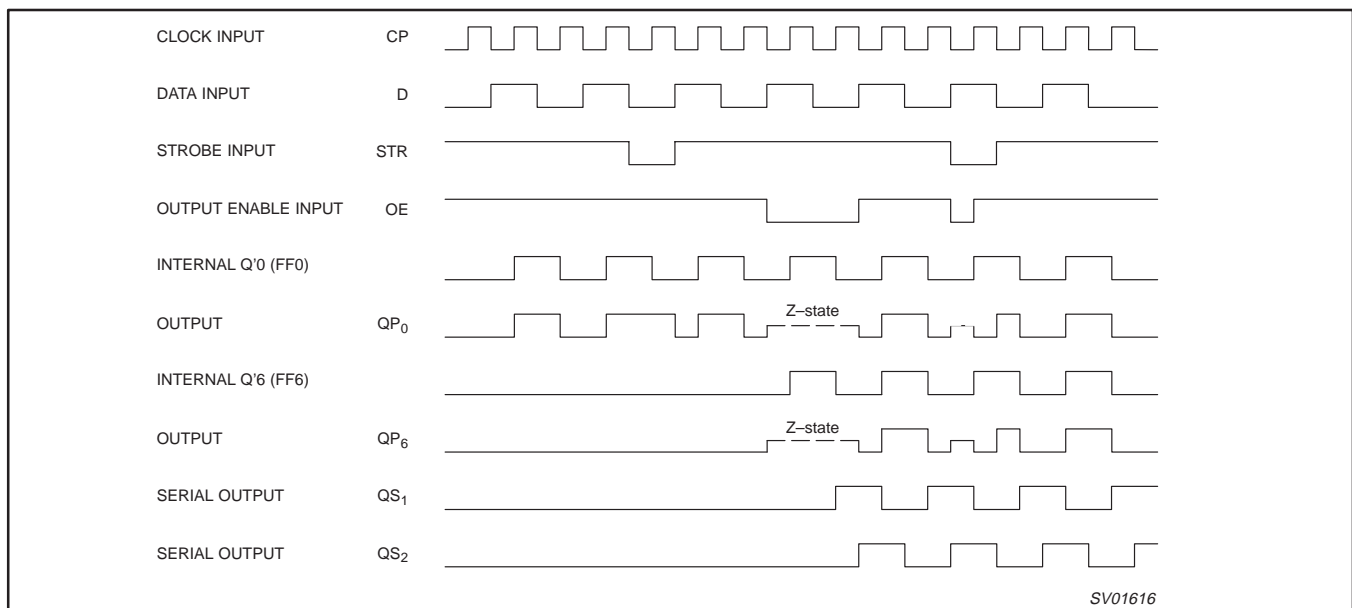

8-stage shift-and-store bus register

74LV4094

ABSOLUTE MAXIMUM RATINGS NO TAG, NO TAG

In accordance with the Absolute Maximum Rating System (IEC 134).

Voltages are referenced to GND (ground = 0 V).

SYMBOL	PARAMETER	CONDITIONS	RATING	UNIT
V_{CC}	DC supply voltage		-0.5 to +7.0	V
$\pm I_{IK}$	DC input diode current	$V_I < -0.5$ or $V_I > V_{CC} + 0.5V$	20	mA
$\pm I_{OK}$	DC output diode current	$V_O < -0.5$ or $V_O > V_{CC} + 0.5V$	50	mA
$\pm I_O$	DC output source or sink current – standard outputs	$-0.5V < V_O < V_{CC} + 0.5V$	25	mA
$\pm I_{GND},$ $\pm I_{CC}$	DC V_{CC} or GND current for types with – standard outputs		50	mA
T_{stg}	Storage temperature range		-65 to +150	°C
P_{TOT}	Power dissipation per package – plastic DIL – plastic mini-pack (SO) – plastic shrink mini-pack (SSOP and TSSOP)	for temperature range: -40 to +125°C above +70°C derate linearly with 12 mW/K above +70°C derate linearly with 8 mW/K above +60°C derate linearly with 5.5 mW/K	750 500 400	mW

NOTES:

- Stresses beyond those listed may cause permanent damage to the device. These are stress ratings only and functional operation of the device at these or any other conditions beyond those indicated under "recommended operating conditions" is not implied. Exposure to absolute-maximum-rated conditions for extended periods may affect device reliability.
- The input and output voltage ratings may be exceeded if the input and output current ratings are observed.

RECOMMENDED OPERATING CONDITIONS

SYMBOL	PARAMETER	CONDITIONS	MIN	TYP	MAX	UNIT
V_{CC}	DC supply voltage	See Note NO TAG	1.0	3.3	3.6	V
V_I	Input voltage		0	–	V_{CC}	V
V_O	Output voltage		0	–	V_{CC}	V
T_{amb}	Operating ambient temperature range in free air	See DC and AC characteristics	-40 -40		+85 +125	°C
t_r, t_f	Input rise and fall times except for Schmitt-trigger inputs	$V_{CC} = 1.0V$ to $2.0V$ $V_{CC} = 2.0V$ to $2.7V$ $V_{CC} = 2.7V$ to $3.6V$	– – –	– – –	500 200 100	ns/V

NOTE:

- The LV is guaranteed to function down to $V_{CC} = 1.0V$ (input levels GND or V_{CC}); DC characteristics are guaranteed from $V_{CC} = 1.2V$ to $V_{CC} = 5.5V$.

8-stage shift-and-store bus register

74LV4094

DC ELECTRICAL CHARACTERISTICS

Over recommended operating conditions, voltages are referenced to GND (ground = 0 V)

SYMBOL	PARAMETER	TEST CONDITIONS	LIMITS					UNIT
			-40°C to +85°C			-40°C to +125°C		
			MIN	TYP NO TAG	MAX	MIN	MAX	
V_{IH}	HIGH level Input voltage	$V_{CC} = 1.2\text{ V}$	V_{CC}	0.6		V_{CC}		V
		$V_{CC} = 2.0\text{ V}$	1.4			1.4		
		$V_{CC} = 2.7\text{ to }3.6\text{ V}$	2.0			2.0		
V_{IL}	LOW level Input voltage	$V_{CC} = 1.2\text{ V}$		0.4	GND		GND	V
		$V_{CC} = 2.0\text{ V}$			0.6		0.6	
		$V_{CC} = 2.7\text{ to }3.6\text{ V}$			0.8		0.8	
V_{OH}	HIGH level output voltage; all outputs	$V_{CC} = 1.2\text{ V}; V_I = V_{IH}\text{ or }V_{IL}; -I_O = 100\mu\text{A}$		1.2				V
		$V_{CC} = 2.0\text{ V}; V_I = V_{IH}\text{ or }V_{IL}; -I_O = 100\mu\text{A}$	1.8	2.0		1.8		
		$V_{CC} = 2.7\text{ V}; V_I = V_{IH}\text{ or }V_{IL}; -I_O = 100\mu\text{A}$	2.5	2.7		2.5		
		$V_{CC} = 3.0\text{ V}; V_I = V_{IH}\text{ or }V_{IL}; -I_O = 100\mu\text{A}$	2.8	3.0		2.8		
V_{OH}	HIGH level output voltage; STANDARD outputs	$V_{CC} = 3.0\text{ V}; V_I = V_{IH}\text{ or }V_{IL}; -I_O = 6\text{mA}$	2.40	2.82		2.20		V
V_{OL}	LOW level output voltage; all outputs	$V_{CC} = 1.2\text{ V}; V_I = V_{IH}\text{ or }V_{IL}; I_O = 100\mu\text{A}$		0				V
		$V_{CC} = 2.0\text{ V}; V_I = V_{IH}\text{ or }V_{IL}; I_O = 100\mu\text{A}$		0	0.2		0.2	
		$V_{CC} = 2.7\text{ V}; V_I = V_{IH}\text{ or }V_{IL}; I_O = 100\mu\text{A}$		0	0.2		0.2	
		$V_{CC} = 3.0\text{ V}; V_I = V_{IH}\text{ or }V_{IL}; I_O = 100\mu\text{A}$		0	0.2		0.2	
V_{OL}	LOW level output voltage; STANDARD outputs	$V_{CC} = 3.0\text{ V}; V_I = V_{IH}\text{ or }V_{IL}; I_O = 6\text{mA}$		0.25	0.40		0.50	V
I_I	Input leakage current	$V_{CC} = 3.6\text{ V}; V_I = V_{CC}\text{ or GND}$			1.0		1.0	μA
I_{OZ}	3-State output OFF-state current	$V_{CC} = 3.6\text{ V}; V_I = V_{IH}\text{ or }V_{IL}; V_O = V_{CC}\text{ or GND}$			5		10	μA
I_{CC}	Quiescent supply current; SSI	$V_{CC} = 3.6; V_I = V_{CC}\text{ or GND}; I_O = 0$			20.0		40	μA
I_{CC}	Quiescent supply current; flip-flops	$V_{CC} = 3.6; V_I = V_{CC}\text{ or GND}; I_O = 0$			20.0		80	μA
	Quiescent supply current; MSI	$V_{CC} = 3.6\text{ V}; V_I = V_{CC}\text{ or GND}; I_O = 0$			20.0		160	μA
	Quiescent supply current; LSI	$V_{CC} = 3.6\text{ V}; V_I = V_{CC}\text{ or GND}; I_O = 0$			500		1000	
ΔI_{CC}	Additional quiescent supply current per input	$V_{CC} = 2.7\text{ V to }3.6\text{ V}; V_I = V_{CC} - 0.6\text{ V}$			500		850	μA

NOTE:

1. All typical values are measured at $T_{amb} = 25^\circ\text{C}$.

8-stage shift-and-store bus register

74LV4094

AC CHARACTERISTICS

GND = 0 V; $t_r = t_f \leq 2.5\text{ns}$; $C_L = 50\text{pF}$

SYMBOL	PARAMETER	WAVEFORM	CONDITION	LIMITS					UNIT
				-40 to +85 °C			-40 to +125 °C		
				V_{CC} (V)	MIN	TYP ¹	MAX	MIN	
t_{PHL}/t_{PLH}	Propagation delay CP to QS ₁		1.2		90			ns	
			2.0		31	58	70		
			2.7		23	43	51		
			3.0 to 3.6		17 ²	34	41		
t_{PHL}/t_{PLH}	Propagation delay CP to QS ₂		1.2		80			ns	
			2.0		27	51	61		
			2.7		20	38	45		
			3.0 to 3.6		14 ²	30	36		
t_{PHL}/t_{PLH}	Propagation delay CP to QP _n		1.2		115			ns	
			2.0		39	75	90		
			2.7		29	55	66		
			3.0 to 3.6		22 ²	44	53		
t_{PHL}/t_{PLH}	Propagation delay STR to QP _n		1.2		105			ns	
			2.0		36	68	82		
			2.7		26	50	60		
			3.0 to 3.6		20 ²	40	48		
t_{PZH}/t_{PZL}	3-State Output enable time OE to QP _n		1.2		100			ns	
			2.0		34	65	77		
			2.7		25	48	56		
			3.0 to 3.6		19 ²	38	45		
t_{PHZ}/t_{PLZ}	3-State Output disable time OE to QP _n		1.2		65			ns	
			2.0		24	40	49		
			2.7		18	32	37		
			3.0 to 3.6		14 ²	26	30		
t_w	Clock pulse width HIGH or LOW		2.0	34	9		41	ns	
			2.7	25	6		30		
			3.0 to 3.6	20	5 ²		24		
t_w	Strobe pulse width; HIGH		2.0	34	9		41	ns	
			2.7	25	6		30		
			3.0 to 3.6	20	5 ²		24		
t_{su}	Set-up time D to CP		1.2		25			ns	
			2.0	22	9		26		
			2.7	16	6		19		
			3.0 to 3.6	13	5 ²		15		
t_{su}	Set-up time CP to STR		1.2		50			ns	
			2.0	43	17		51		
			2.7	31	13		38		
			3.0 to 3.6	25	10 NO TAG		30		

8-stage shift-and-store bus register

74LV4094

SYMBOL	PARAMETER	WAVEFORM	CONDITION						UNIT
			V_{CC} (V)	-40 to +85 °C			-40 to +125 °C		
				MIN	TYP ¹	MAX	MIN	MAX	
T_h	Hold time D to CP		1.2		-10				ns
			2.0	5	-4		5		
			2.7	5	-3		5		
			3.0 to 3.6	5	-2 NO TAG		5		

NOTES:

1. Unless otherwise stated, all typical values are measured at $T_{amb} = 25^{\circ}C$
2. Typical values are measured at $V_{CC} = 3.3 V$.

8-stage shift-and-store bus register

74LV4094

AC CHARACTERISTICS (Continued)

GND = 0 V; $t_r = t_f \leq 2.5\text{ns}$; $C_L = 50\text{pF}$

SYMBOL	PARAMETER	WAVEFORM	CONDITION		-40 to +85 °C			-40 to +125 °C		UNIT
			V_{CC} (V)		MIN	TYP ¹	MAX	MIN	MAX	
T_h	Hold time D to STR		1.2			-25				ns
			2.0	5		-9		5		
			2.7	5		-6		5		
			3.0 to 3.6	5		-5 ²		5		
f_{max}	Maximum clock pulse frequency		2.0	14	52		12		MHz	
			2.7	19	70		16			
			3.0 to 3.6	24	87 ²		20			

NOTES:

1. Unless otherwise stated, all typical values are measured at $T_{amb} = 25^\circ\text{C}$
2. Typical values are measured at $V_{CC} = 3.3\text{ V}$.

AC WAVEFORMS

$V_M = 1.5\text{ V}$ at $V_{CC} \geq 2.7\text{ V}$
 $V_M = 0.5 \times V_{CC}$ at $V_{CC} < 2.7\text{ V}$.
 V_{OL} and V_{OH} are the typical output voltage drop that occur with the output load.
 $V_X = V_{OL} + 0.3\text{ V}$ at $V_{CC} \geq 2.7\text{ V}$
 $V_X = V_{OL} + 0.1 \times V_{CC}$ at $V_{CC} < 2.7\text{ V}$
 $V_Y = V_{OH} \pm 0.3\text{ V}$ at $V_{CC} \geq 2.7\text{ V}$
 $V_Y = V_{OH} \pm 0.1 \times V_{CC}$ at $V_{CC} < 2.7\text{ V}$

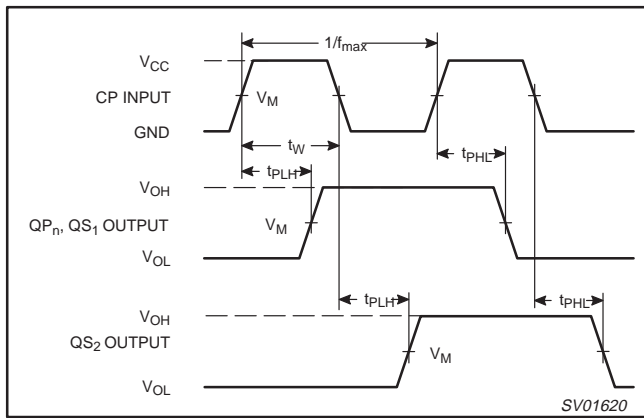

Figure 1. Clock (CP) to output (QP_n , QS_1 , QS_2) propagation delays, the clock pulse width and the maximum clock frequency.

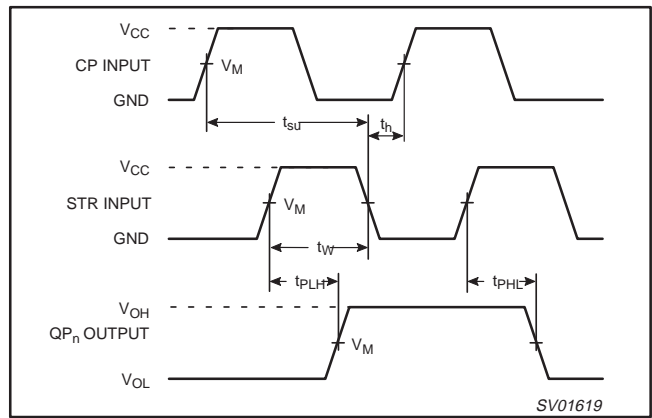

Figure 2. Strobe (STR) to output (QP_n) propagation delays and the strobe pulse width and the clock set-up and hold times for strobe input.

8-stage shift-and-store bus register

74LV4094

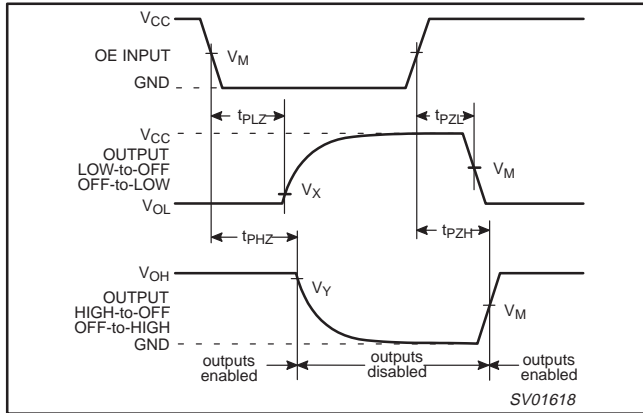

Figure 3. 3-State enable and disable times for input OE.

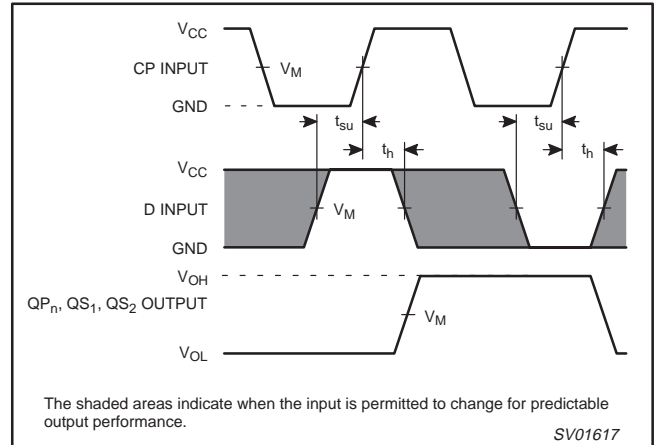

Figure 4. Data set-up and hold times for the data input (D).

TEST CIRCUIT

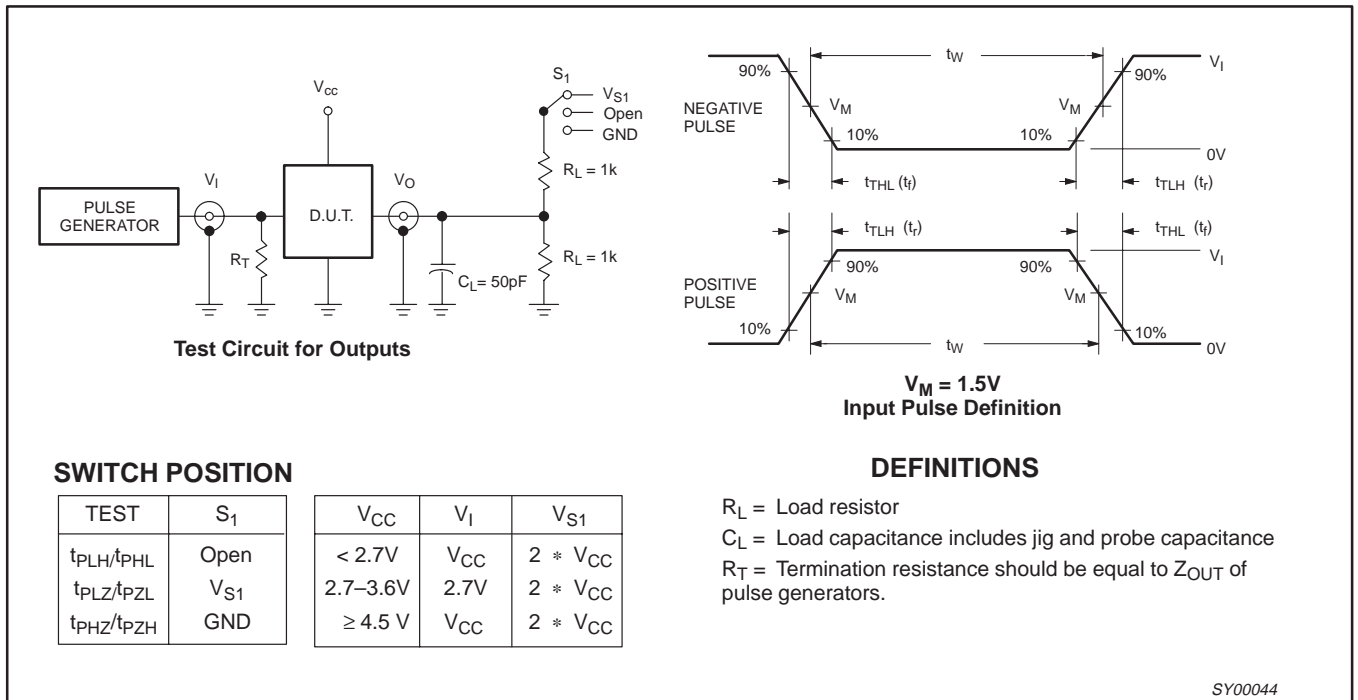

Figure 5. Load circuitry for switching times.

8-stage shift-and-store bus register

74LV4094

DIP16: plastic dual in-line package; 16 leads (300 mil)

SOT38-4

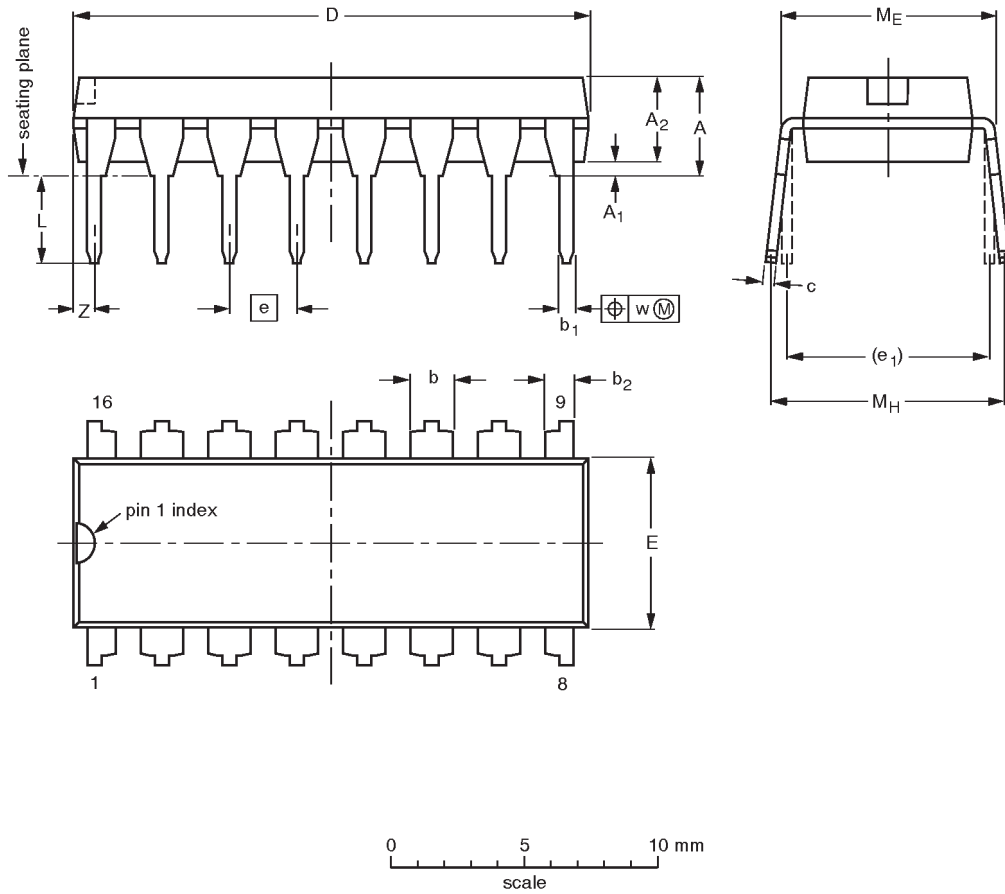

DIMENSIONS (inch dimensions are derived from the original mm dimensions)

UNIT	A max.	A ₁ min.	A ₂ max.	b	b ₁	b ₂	c	D ⁽¹⁾	E ⁽¹⁾	e	e ₁	L	M _E	M _H	w	Z ⁽¹⁾ max.
mm	4.2	0.51	3.2	1.73 1.30	0.53 0.38	1.25 0.85	0.36 0.23	19.50 18.55	6.48 6.20	2.54	7.62	3.60 3.05	8.25 7.80	10.0 8.3	0.254	0.76
inches	0.17	0.020	0.13	0.068 0.051	0.021 0.015	0.049 0.033	0.014 0.009	0.77 0.73	0.26 0.24	0.10	0.30	0.14 0.12	0.32 0.31	0.39 0.33	0.01	0.030

Note

1. Plastic or metal protrusions of 0.25 mm maximum per side are not included.

OUTLINE VERSION	REFERENCES				EUROPEAN PROJECTION	ISSUE DATE
	IEC	JEDEC	EIAJ			
SOT38-4						92-11-17 95-01-14

8-stage shift-and-store bus register

74LV4094

SO16: plastic small outline package; 16 leads; body width 3.9 mm

SOT109-1

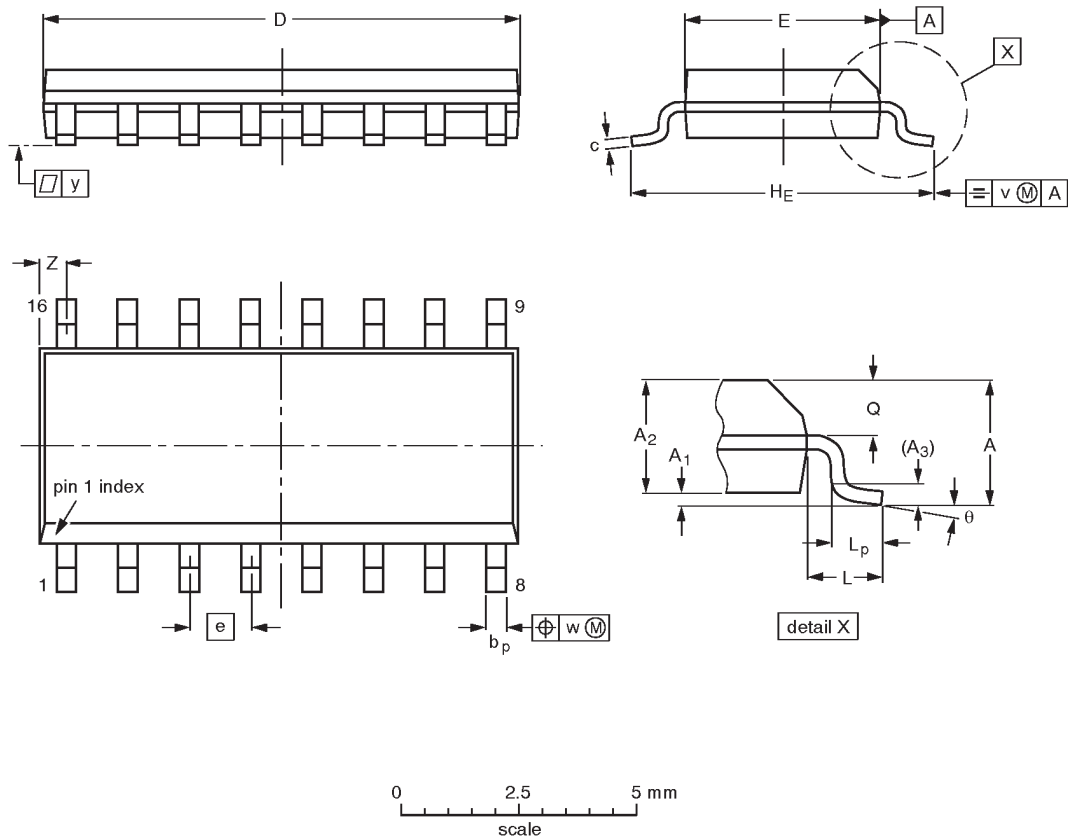

DIMENSIONS (inch dimensions are derived from the original mm dimensions)

UNIT	A max.	A ₁	A ₂	A ₃	b _p	c	D ⁽¹⁾	E ⁽¹⁾	e	H _E	L	L _p	Q	v	w	y	z ⁽¹⁾	θ
mm	1.75	0.25 0.10	1.45 1.25	0.25	0.49 0.36	0.25 0.19	10.0 9.8	4.0 3.8	1.27	6.2 5.8	1.05	1.0 0.4	0.7 0.6	0.25	0.25	0.1	0.7 0.3	8° 0°
inches	0.069	0.0098 0.0039	0.057 0.049	0.01	0.019 0.014	0.0098 0.0075	0.39 0.38	0.16 0.15	0.050	0.24 0.23	0.041	0.039 0.016	0.028 0.020	0.01	0.01	0.004	0.028 0.012	

Note

1. Plastic or metal protrusions of 0.15 mm maximum per side are not included.

OUTLINE VERSION	REFERENCES				EUROPEAN PROJECTION	ISSUE DATE
	IEC	JEDEC	EIAJ			
SOT109-1	076E07S	MS-012AC				91-08-13 95-01-23

8-stage shift-and-store bus register

74LV4094

NOTES

8-stage shift-and-store bus register

74LV4094

Data sheet status

Data sheet status	Product status	Definition [1]
Objective specification	Development	This data sheet contains the design target or goal specifications for product development. Specification may change in any manner without notice.
Preliminary specification	Qualification	This data sheet contains preliminary data, and supplementary data will be published at a later date. Philips Semiconductors reserves the right to make changes at any time without notice in order to improve design and supply the best possible product.
Product specification	Production	This data sheet contains final specifications. Philips Semiconductors reserves the right to make changes at any time without notice in order to improve design and supply the best possible product.

[1] Please consult the most recently issued datasheet before initiating or completing a design.

Definitions

Short-form specification — The data in a short-form specification is extracted from a full data sheet with the same type number and title. For detailed information see the relevant data sheet or data handbook.

Limiting values definition — Limiting values given are in accordance with the Absolute Maximum Rating System (IEC 134). Stress above one or more of the limiting values may cause permanent damage to the device. These are stress ratings only and operation of the device at these or at any other conditions above those given in the Characteristics sections of the specification is not implied. Exposure to limiting values for extended periods may affect device reliability.

Application information — Applications that are described herein for any of these products are for illustrative purposes only. Philips Semiconductors make no representation or warranty that such applications will be suitable for the specified use without further testing or modification.

Disclaimers

Life support — These products are not designed for use in life support appliances, devices or systems where malfunction of these products can reasonably be expected to result in personal injury. Philips Semiconductors customers using or selling these products for use in such applications do so at their own risk and agree to fully indemnify Philips Semiconductors for any damages resulting from such application.

Right to make changes — Philips Semiconductors reserves the right to make changes, without notice, in the products, including circuits, standard cells, and/or software, described or contained herein in order to improve design and/or performance. Philips Semiconductors assumes no responsibility or liability for the use of any of these products, conveys no license or title under any patent, copyright, or mask work right to these products, and makes no representations or warranties that these products are free from patent, copyright, or mask work right infringement, unless otherwise specified.

Philips Semiconductors
811 East Arques Avenue
P.O. Box 3409
Sunnyvale, California 94088-3409
Telephone 800-234-7381

© Copyright Philips Electronics North America Corporation 1998
All rights reserved. Printed in U.S.A.

print code

Date of release: 08-98

Document order number:

9397-750-04662

Let's make things better.



LittleDiode supplies new, hard to find or obsolete electronic components and semiconductors all over the world.

With over two million different components listed you are sure to find the part you need.

Feel free to visit us today at our online store:

LittleDiode.com

Looking forward to providing you with the best possible service.