

DATA SHEET

74LV74

Dual D-type flip-flop with set and reset;
positive-edge trigger

Product specification
Supersedes data of 1996 Nov 07
IC24 Data Handbook

1998 Apr 20

Dual D-type flip-flop with set and reset; positive edge-trigger

74LV74

FEATURES

- Wide operating voltage: 1.0 to 5.5V
- Optimized for Low Voltage applications: 1.0 to 3.6V
- Accepts TTL input levels between $V_{CC} = 2.7V$ and $V_{CC} = 3.6V$
- Typical V_{OLP} (output ground bounce) $< 0.8V$ @ $V_{CC} = 3.3V$, $T_{amb} = 25^{\circ}C$
- Typical V_{OHV} (output V_{OH} undershoot) $> 2V$ @ $V_{CC} = 3.3V$, $T_{amb} = 25^{\circ}C$
- Output capability: standard
- I_{CC} category: flip-flops

DESCRIPTION

The 74LV74 is a low-voltage Si-gate CMOS device and is pin and function compatible with 74HC/HCT74.

The 74LV74 is a dual positive edge triggered, D-type flip-flop with individual data (D) inputs, clock (CP) inputs, set (\overline{S}_D) and (\overline{R}_D) inputs; also complementary Q and \overline{Q} outputs.

The set and reset are asynchronous active LOW inputs and operate independently of the clock input. Information on the data input is transferred to the Q output on the LOW-to-HIGH transition of the clock pulse. The D inputs must be stable one set-up time prior to the LOW-to-HIGH clock transition, for predictable operation.

Schmitt-trigger action in the clock input makes the circuit highly tolerant to slower clock rise and fall times.

QUICK REFERENCE DATA

GND = 0V; $T_{amb} = 25^{\circ}C$; $t_r = t_f \leq 2.5$ ns

SYMBOL	PARAMETER	CONDITIONS	TYPICAL	UNIT
t_{PHL}/t_{PLH}	Propagation delay nCP to nQ, n \overline{Q} n \overline{S}_D to nQ, n \overline{Q} n \overline{R}_D to nQ, n \overline{Q}	$C_L = 15pF$ $V_{CC} = 3.3V$	11 14 14	ns
f_{max}	Maximum clock frequency	$C_L = 15pF$ $V_{CC} = 3.3V$	76	MHz
C_I	Input capacitance		3.5	pF
C_{PD}	Power dissipation capacitance per flip-flop	Notes 1 and 2	24	pF

NOTES:

1. C_{PD} is used to determine the dynamic power dissipation (P_D in μW)
 $P_D = C_{PD} \times V_{CC}^2 \times f_i + \sum (C_L \times V_{CC}^2 \times f_o)$ where:
 f_i = input frequency in MHz; C_L = output load capacitance in pF;
 f_o = output frequency in MHz; V_{CC} = supply voltage in V;
 $\sum (C_L \times V_{CC}^2 \times f_o)$ = sum of the outputs.
2. The condition is $V_I = GND$ to V_{CC}

ORDERING INFORMATION

PACKAGES	TEMPERATURE RANGE	OUTSIDE NORTH AMERICA	NORTH AMERICA	PKG. DWG. #
14-Pin Plastic DIL	-40°C to +125°C	74LV74 N	74LV74 N	SOT27-1
14-Pin Plastic SO	-40°C to +125°C	74LV74 D	74LV74 D	SOT108-1
14-Pin Plastic SSOP Type II	-40°C to +125°C	74LV74 DB	74LV74 DB	SOT337-1
14-Pin Plastic TSSOP Type I	-40°C to +125°C	74LV74 PW	74LV74PW DH	SOT402-1

PIN DESCRIPTION

PIN NUMBER	SYMBOL	FUNCTION
1, 13	$1\overline{R}_D, 2\overline{R}_D$	Asynchronous reset-direct input (active-LOW)
2, 12	1D, 2D	Data inputs
3, 11	1CP, 2CP	Clock input (LOW-to-HIGH), edge-triggered)
4, 10	$1\overline{S}_D, 2\overline{S}_D$	Asynchronous set-direct input (active-LOW)
5, 9	1Q, 2Q	True flip-flop outputs
6, 8	$1\overline{Q}, 2\overline{Q}$	Complement flip-flop outputs
7	GND	Ground (0V)
14	V_{CC}	Positive supply voltage

FUNCTION TABLE

INPUTS				OUTPUTS	
\overline{S}_D	\overline{R}_D	CP	D	Q	\overline{Q}
L	H	X	X	H	L
H	L	X	X	L	H
L	L	X	X	H	H

INPUTS				OUTPUTS	
\overline{S}_D	\overline{R}_D	CP	D	Q_{n+1}	\overline{Q}_{n+1}
H	H	↑	L	L	H
H	H	↑	H	H	L

H = HIGH voltage level
 L = LOW voltage level
 X = don't care
 ↑ = LOW-to-HIGH CP transition
 Q_{n+1} = state after the next LOW-to-HIGH CP transition

Dual D-type flip-flop with set and reset; positive edge-trigger

74LV74

PIN CONFIGURATION

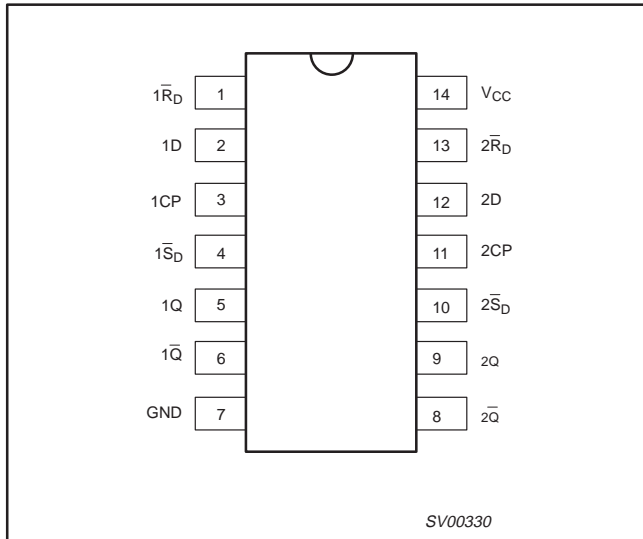

LOGIC SYMBOL

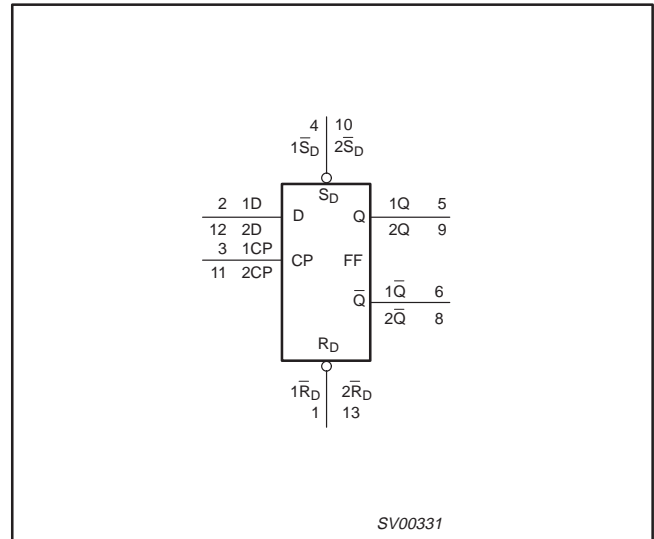

LOGIC SYMBOL (IEEE/IEC)

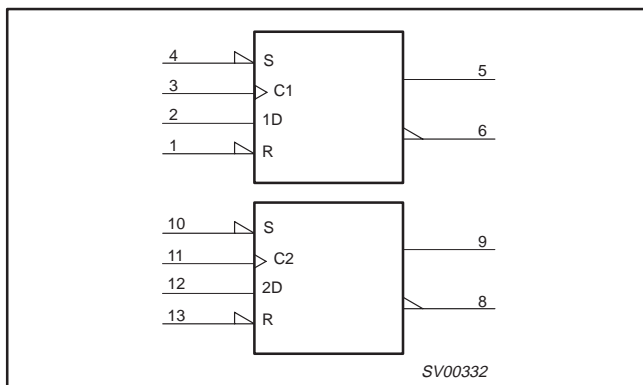

FUNCTIONAL DIAGRAM

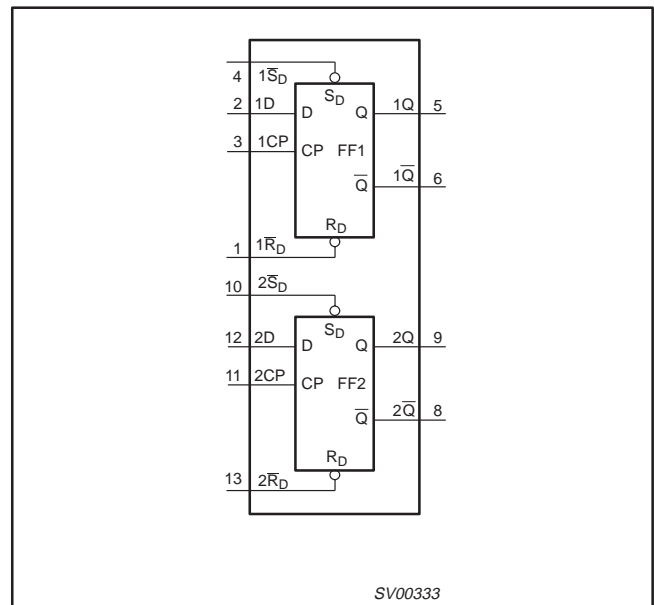

Dual D-type flip-flop with set and reset; positive edge-trigger

74LV74

LOGIC DIAGRAM (ONE FLIP-FLOP)

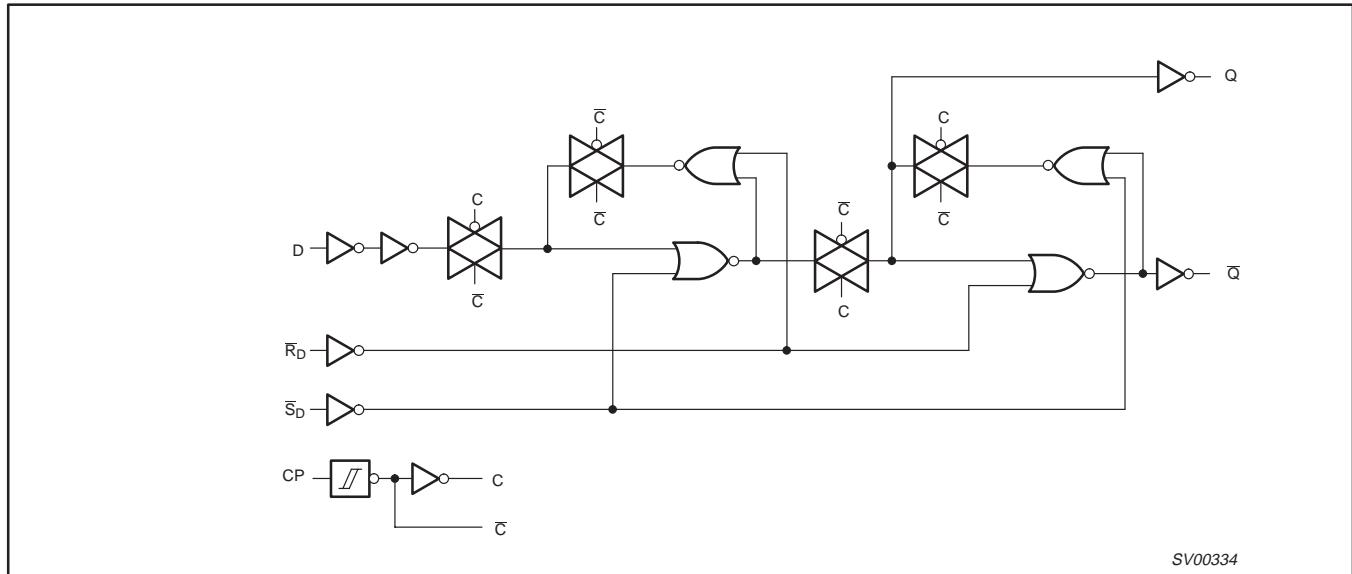

RECOMMENDED OPERATING CONDITIONS

SYMBOL	PARAMETER	CONDITIONS	MIN	TYP.	MAX	UNIT
V_{CC}	DC supply voltage	See Note1	1.0	3.3	5.5	V
V_I	Input voltage		0	–	V_{CC}	V
V_O	Output voltage		0	–	V_{CC}	V
T_{amb}	Operating ambient temperature range in free air	See DC and AC characteristics	–40 –40		+85 +125	°C
t_r, t_f	Input rise and fall times except for Schmitt-trigger inputs	$V_{CC} = 1.0V$ to $2.0V$ $V_{CC} = 2.0V$ to $2.7V$ $V_{CC} = 2.7V$ to $3.6V$ $V_{CC} = 3.6V$ to $5.5V$	– – – –	– – – –	500 200 100 50	ns/V

NOTE:

1. The LV is guaranteed to function down to $V_{CC} = 1.0V$ (input levels GND or V_{CC}); DC characteristics are guaranteed from $V_{CC} = 1.2V$ to $V_{CC} = 5.5V$.

ABSOLUTE MAXIMUM RATINGS^{1, 2}

In accordance with the Absolute Maximum Rating System (IEC 134)
Voltages are referenced to GND (ground = 0V)

SYMBOL	PARAMETER	CONDITIONS	RATING	UNIT
V_{CC}	DC supply voltage		–0.5 to +7.0	V
$\pm I_{IK}$	DC input diode current	$V_I < -0.5$ or $V_I > V_{CC} + 0.5V$	20	mA
$\pm I_{OK}$	DC output diode current	$V_O < -0.5$ or $V_O > V_{CC} + 0.5V$	50	mA
$\pm I_O$	DC output source or sink current – standard outputs	$-0.5V < V_O < V_{CC} + 0.5V$	25	mA
$\pm I_{GND}, \pm I_{CC}$	DC V_{CC} or GND current for types with –standard outputs		50	mA
T_{stg}	Storage temperature range		–65 to +150	°C
P_{tot}	Power dissipation per package –plastic DIL –plastic mini-pack (SO) –plastic shrink mini-pack (SSOP and TSSOP)	for temperature range: –40 to +125°C above +70°C derate linearly with 12mW/K above +70°C derate linearly with 8 mW/K above +60°C derate linearly with 5.5 mW/K	750 500 400	mW

NOTES:

- Stresses beyond those listed may cause permanent damage to the device. These are stress ratings only and functional operation of the device at these or any other conditions beyond those indicated under “recommended operating conditions” is not implied. Exposure to absolute-maximum-rated conditions for extended periods may affect device reliability.
- The input and output voltage ratings may be exceeded if the input and output current ratings are observed.

Dual D-type flip-flop with set and reset; positive edge-trigger

74LV74

DC CHARACTERISTICS

Over recommended operating conditions voltages are referenced to GND (ground = 0V)

SYMBOL	PARAMETER	TEST CONDITIONS	LIMITS					UNIT
			-40°C to +85°C			-40°C to +125°C		
			MIN	TYP ¹	MAX	MIN	MAX	
V _{IH}	HIGH level Input voltage	V _{CC} = 1.2V	0.9			0.9		V
		V _{CC} = 2.0V	1.4			1.4		
		V _{CC} = 2.7 to 3.6V	2.0			2.0		
		V _{CC} = 4.5 to 5.5V	0.7*V _{CC}			0.7*V _{CC}		
V _{IL}	LOW level Input voltage	V _{CC} = 1.2V			0.3		0.3	V
		V _{CC} = 2.0V			0.6		0.6	
		V _{CC} = 2.7 to 3.6V			0.8		0.8	
		V _{CC} = 4.5 to 5.5			0.3*V _{CC}		0.3*V _{CC}	
V _{OH}	HIGH level output voltage; all outputs	V _{CC} = 1.2V; V _I = V _{IH} or V _{IL} ; -I _O = 100µA		1.2				V
		V _{CC} = 2.0V; V _I = V _{IH} or V _{IL} ; -I _O = 100µA	1.8	2.0		1.8		
		V _{CC} = 2.7V; V _I = V _{IH} or V _{IL} ; -I _O = 100µA	2.5	2.7		2.5		
		V _{CC} = 3.0V; V _I = V _{IH} or V _{IL} ; -I _O = 100µA	2.8	3.0		2.8		
		V _{CC} = 4.5V; V _I = V _{IH} or V _{IL} ; -I _O = 100µA	4.3	4.5		4.3		
V _{OH}	HIGH level output voltage; STANDARD outputs	V _{CC} = 3.0V; V _I = V _{IH} or V _{IL} ; -I _O = 6mA	2.40	2.82		2.20		V
		V _{CC} = 4.5V; V _I = V _{IH} or V _{IL} ; -I _O = 12mA	3.60	4.20		3.50		
V _{OL}	LOW level output voltage; all outputs	V _{CC} = 1.2V; V _I = V _{IH} or V _{IL} ; I _O = 100µA		0				V
		V _{CC} = 2.0V; V _I = V _{IH} or V _{IL} ; I _O = 100µA		0	0.2		0.2	
		V _{CC} = 2.7V; V _I = V _{IH} or V _{IL} ; I _O = 100µA		0	0.2		0.2	
		V _{CC} = 3.0V; V _I = V _{IH} or V _{IL} ; I _O = 100µA		0	0.2		0.2	
		V _{CC} = 4.5V; V _I = V _{IH} or V _{IL} ; I _O = 100µA		0	0.2		0.2	
V _{OL}	LOW level output voltage; STANDARD outputs	V _{CC} = 3.0V; V _I = V _{IH} or V _{IL} ; I _O = 6mA		0.25	0.40		0.50	V
		V _{CC} = 4.5V; V _I = V _{IH} or V _{IL} ; I _O = 12mA		0.35	0.55		0.65	
I _I	Input leakage current	V _{CC} = 5.5V; V _I = V _{CC} or GND			1.0		1.0	µA
I _{CC}	Quiescent supply current; flip-flops	V _{CC} = 5.5V; V _I = V _{CC} or GND; I _O = 0			20.0		80	µA
ΔI _{CC}	Additional quiescent supply current per input	V _{CC} = 2.7V to 3.6V; V _I = V _{CC} - 0.6V			500		850	µA

NOTE:

1. All typical values are measured at T_{amb} = 25°C.

Dual D-type flip-flop with set and reset;
positive edge-trigger

74LV74

AC CHARACTERISTICS

GND = 0V; $t_r = t_f \leq 2.5\text{ns}$; $C_L = 50\text{pF}$; $R_L = 1\text{K}\Omega$

SYMBOL	PARAMETER	WAVEFORM	CONDITION	LIMITS -40 to +85 °C			LIMITS -40 to +125 °C		UNIT
				V _{CC} (V)	MIN	TYP ¹	MAX	MIN	
$t_{\text{PHL}}/t_{\text{PLH}}$	Propagation delay nCP to nQ, nQ	Figures, 1, 3	1.2	-	70	-	-	-	ns
			2.0	-	24	44	-	56	
			2.7	-	18	28	-	41	
			3.0 to 3.6	-	13 ²	26	-	33	
			4.5 to 5.5	-	9.5 ³	17	-	23	
$t_{\text{PHL}}/t_{\text{PLH}}$	Propagation delay nSD to nQ, nQ	Figures 2, 3	1.2	-	90	-	-	-	ns
			2.0	-	31	46	-	58	
			2.7	-	23	34	-	43	
			3.0 to 3.6	-	17 ²	27	-	34	
			4.5 to 5.5	-	12 ³	19	-	24	
$t_{\text{PHL}}/t_{\text{PLH}}$	Propagation delay nRD to nQ, nQ	Figures 2, 3	1.2	-	90	-	-	-	ns
			2.0	-	31	46	-	58	
			2.7	-	23	34	-	43	
			3.0 to 3.6	-	17 ²	27	-	34	
			4.5 to 5.5	-	12 ³	19	-	24	
t_w	Clock pulse width HIGH to LOW	Figure 1	2.0	34	10	-	41	-	ns
			2.7	25	8	-	30	-	
			3.0 to 3.6	20	7 ²	-	24	-	
			4.5 to 5.5	15	6 ³	-	18	-	
t_w	Set or reset pulse width LOW	Figure 2	2.0	34	10	-	41	-	ns
			2.7	25	8	-	30	-	
			3.0 to 3.6	20	7 ²	-	24	-	
			4.5 to 5.5	15	6 ³	-	18	-	
t_{rem}	Removal time set or reset	Figure 2	1.2	-	5	-	-	-	ns
			2.0	14	2	-	15	-	
			2.7	10	1	-	11	-	
			3.0 to 3.6	8	1 ²	-	9	-	
			4.5 to 5.5	6	1 ³	-	7	-	
t_{su}	Set-up time nD to nCP	Figure 1	1.2	-	10	-	-	-	ns
			2.0	22	4	-	26	-	
			2.7	12	3	-	15	-	
			3.0 to 3.6	8	2 ²	-	10	-	
			4.5 to 5.5	6	1 ²	-	8	-	
t_h	Hold time nD to nCP	Figure 1	1.2	-	-10	-	-	-	ns
			2.0	3	-2	-	3	-	
			2.7	3	-2	-	3	-	
			3.0 to 3.6	3	-2 ²	-	3	-	
			4.5 to 5.5	3	-2 ³	-	3	-	
f_{max}	Maximum clock pulse frequency	Figure 1	2.0	14	40	-	12	-	MHz
			2.7	50	90	-	40	-	
			3.0 to 3.6	60	100 ²	-	48	-	
			4.5 to 5.5	70	110 ³	-	56	-	

NOTE:

1. Unless otherwise stated, all typical values are at $T_{\text{amb}} = 25^\circ\text{C}$.
2. Typical value measured at $V_{\text{CC}} = 3.3\text{V}$.
3. Typical value measured at $V_{\text{CC}} = 5.0\text{V}$.

Dual D-type flip-flop with set and reset; positive edge-trigger

74LV74

AC WAVEFORMS

$V_M = 1.5V$ at $V_{CC} \geq 2.7V \leq 3.6V$
 $V_M = 0.5 * V_{CC}$ at $V_{CC} < 2.7V$ and $\geq 4.5V$
 V_{OL} and V_{OH} are the typical output voltage drop that occur with the output load.

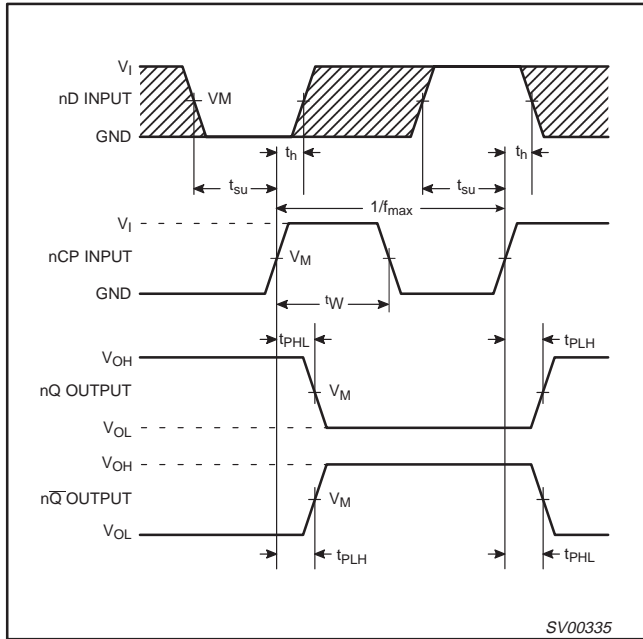

Figure 1. The clock (nCP) to output (nQ, nQ-bar) propagation delays, the clock pulse width, the nD to nCP setup times, the nCP to nD hold times, the output transition times and the maximum clock pulse frequency

NOTE:

The shaded areas indicate when the input is permitted to change for predictable output performance.

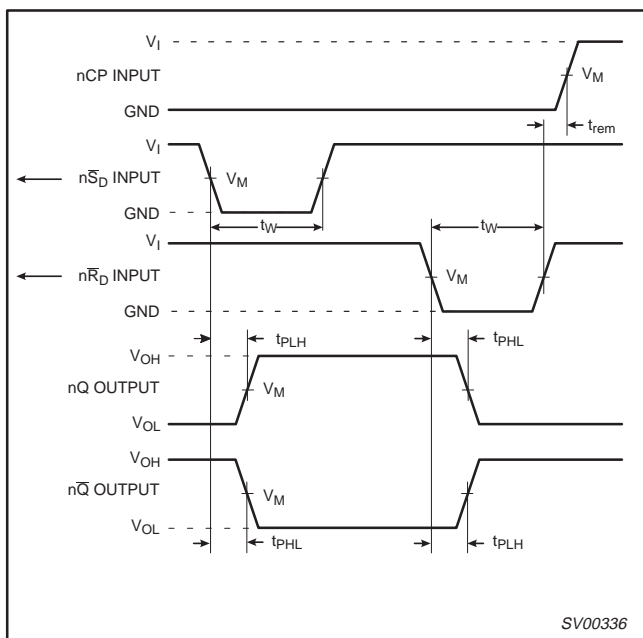

Figure 2. The set (nS-D) and reset (nR-D) input to output (nQ, nQ-bar) propagation delays, the set and reset pulse widths and the nR-D to nCP removal time

TEST CIRCUIT

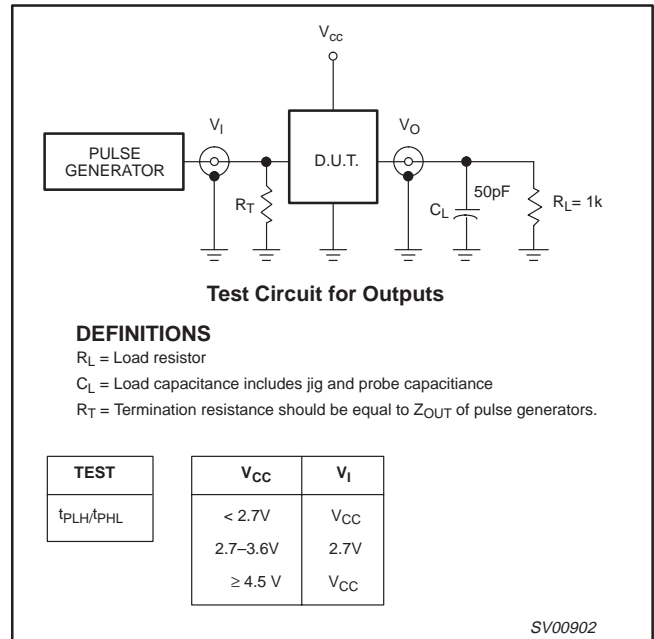

Figure 3. Load circuitry for switching times

Dual D-type flip-flop with set and reset; positive edge-trigger

74LV74

DIP14: plastic dual in-line package; 14 leads (300 mil)

SOT27-1

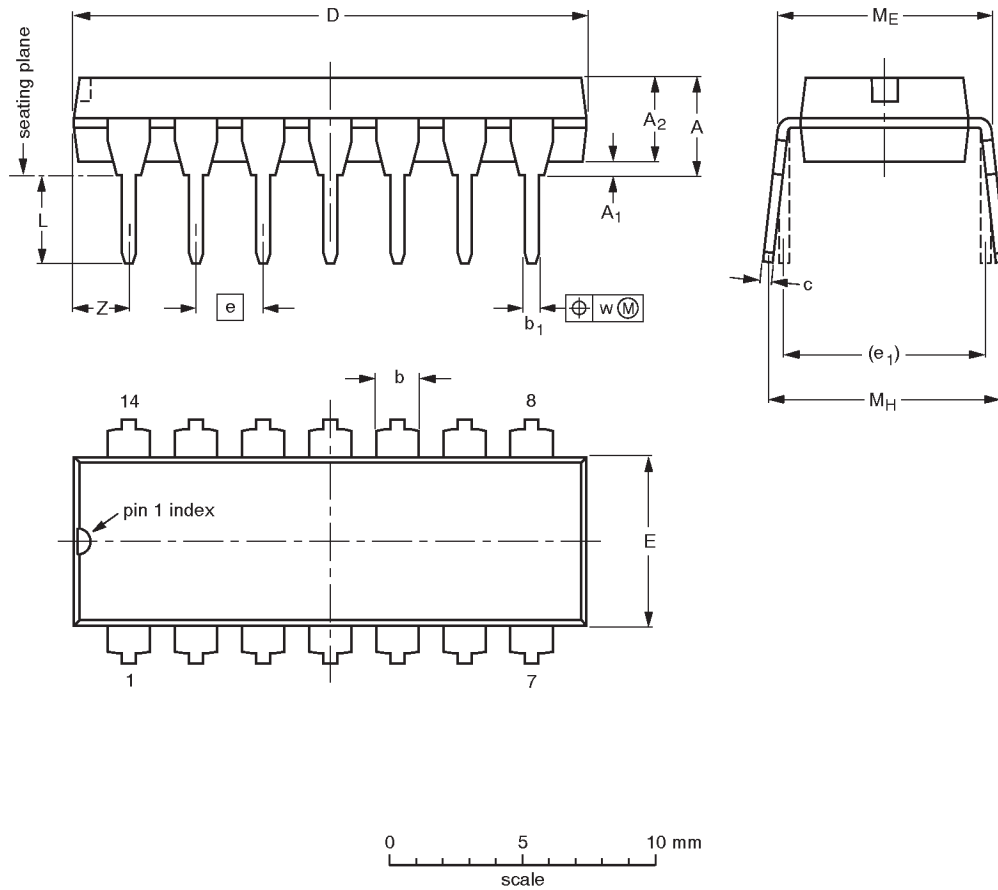

DIMENSIONS (inch dimensions are derived from the original mm dimensions)

UNIT	A max.	A ₁ min.	A ₂ max.	b	b ₁	c	D ⁽¹⁾	E ⁽¹⁾	e	e ₁	L	M _E	M _H	w	Z ⁽¹⁾ max.
mm	4.2	0.51	3.2	1.73 1.13	0.53 0.38	0.36 0.23	19.50 18.55	6.48 6.20	2.54	7.62	3.60 3.05	8.25 7.80	10.0 8.3	0.254	2.2
inches	0.17	0.020	0.13	0.068 0.044	0.021 0.015	0.014 0.009	0.77 0.73	0.26 0.24	0.10	0.30	0.14 0.12	0.32 0.31	0.39 0.33	0.01	0.087

Note

1. Plastic or metal protrusions of 0.25 mm maximum per side are not included.

OUTLINE VERSION	REFERENCES			EUROPEAN PROJECTION	ISSUE DATE
	IEC	JEDEC	EIAJ		
SOT27-1	050G04	MO-001AA			92-11-17 95-03-11

Dual D-type flip-flop with set and reset; positive edge-trigger

74LV74

SO14: plastic small outline package; 14 leads; body width 3.9 mm

SOT108-1

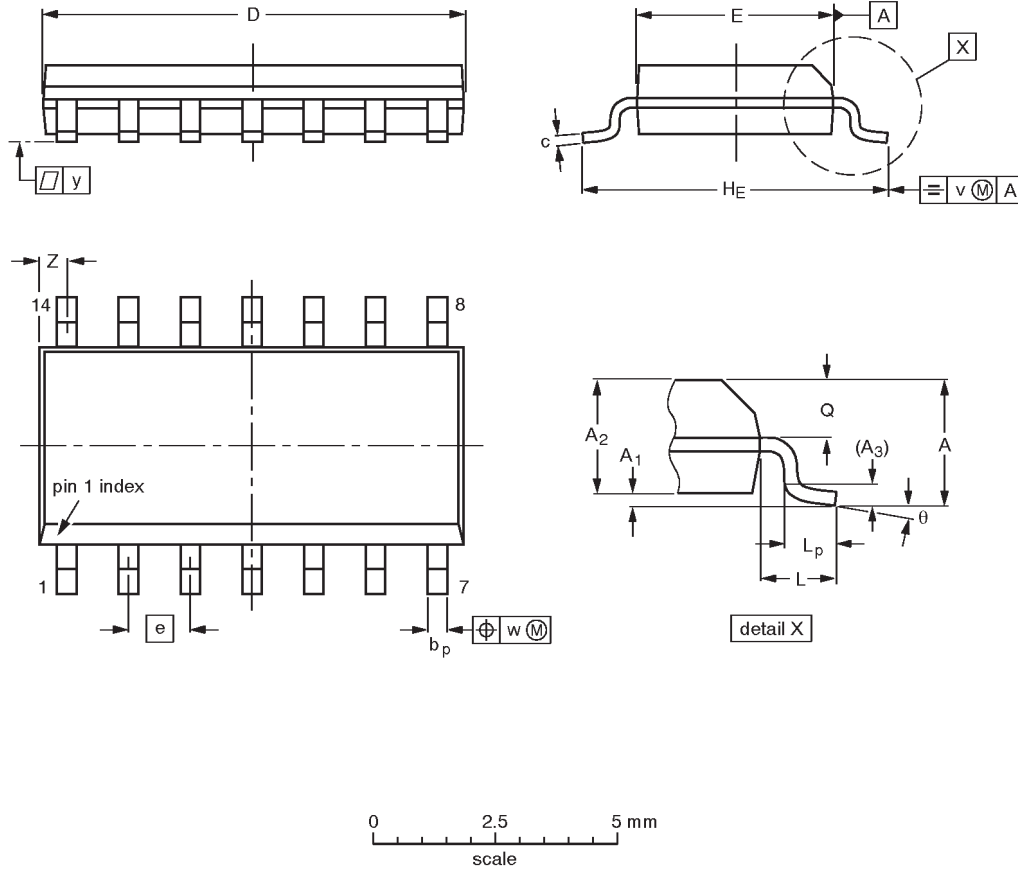

DIMENSIONS (inch dimensions are derived from the original mm dimensions)

UNIT	A max.	A ₁	A ₂	A ₃	b _p	c	D ⁽¹⁾	E ⁽¹⁾	e	HE	L	L _p	Q	v	w	y	Z ⁽¹⁾	θ
mm	1.75	0.25 0.10	1.45 1.25	0.25	0.49 0.36	0.25 0.19	8.75 8.55	4.0 3.8	1.27	6.2 5.8	1.05	1.0 0.4	0.7 0.6	0.25	0.25	0.1	0.7 0.3	8° 0°
inches	0.069	0.0098 0.0039	0.057 0.049	0.01	0.019 0.014	0.0098 0.0075	0.35 0.34	0.16 0.15	0.050	0.24 0.23	0.041	0.039 0.016	0.028 0.024	0.01	0.01	0.004	0.028 0.012	

Note

1. Plastic or metal protrusions of 0.15 mm maximum per side are not included.

OUTLINE VERSION	REFERENCES				EUROPEAN PROJECTION	ISSUE DATE
	IEC	JEDEC	EIAJ			
SOT108-1	076E06S	MS-012AB				91-08-13 95-01-23

Dual D-type flip-flop with set and reset; positive edge-trigger

74LV74

SSOP14: plastic shrink small outline package; 14 leads; body width 5.3 mm

SOT337-1

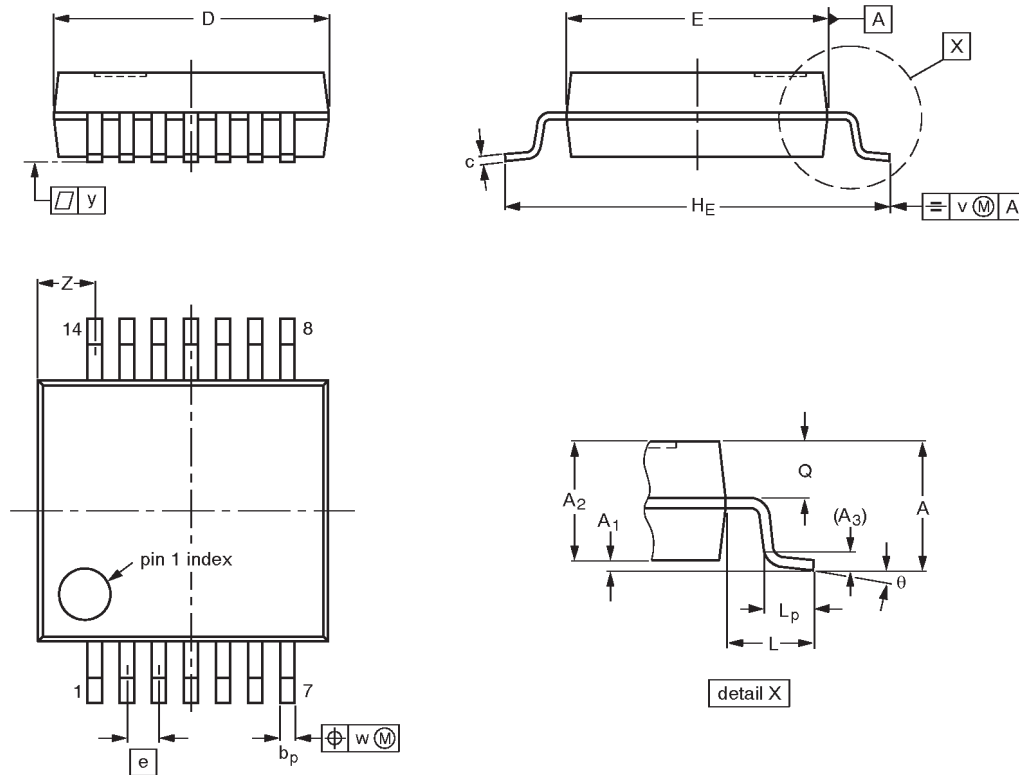

DIMENSIONS (mm are the original dimensions)

UNIT	A max.	A ₁	A ₂	A ₃	b _p	c	D ⁽¹⁾	E ⁽¹⁾	e	H _E	L	L _p	Q	v	w	y	Z ⁽¹⁾	θ
mm	2.0	0.21 0.05	1.80 1.65	0.25	0.38 0.25	0.20 0.09	6.4 6.0	5.4 5.2	0.65	7.9 7.6	1.25	1.03 0.63	0.9 0.7	0.2	0.13	0.1	1.4 0.9	8° 0°

Note

1. Plastic or metal protrusions of 0.25 mm maximum per side are not included.

OUTLINE VERSION	REFERENCES				EUROPEAN PROJECTION	ISSUE DATE
	IEC	JEDEC	EIAJ			
SOT337-1		MO-150AB				95-02-04 96-01-18

Dual D-type flip-flop with set and reset; positive edge-trigger

74LV74

TSSOP14: plastic thin shrink small outline package; 14 leads; body width 4.4 mm

SOT402-1

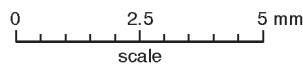
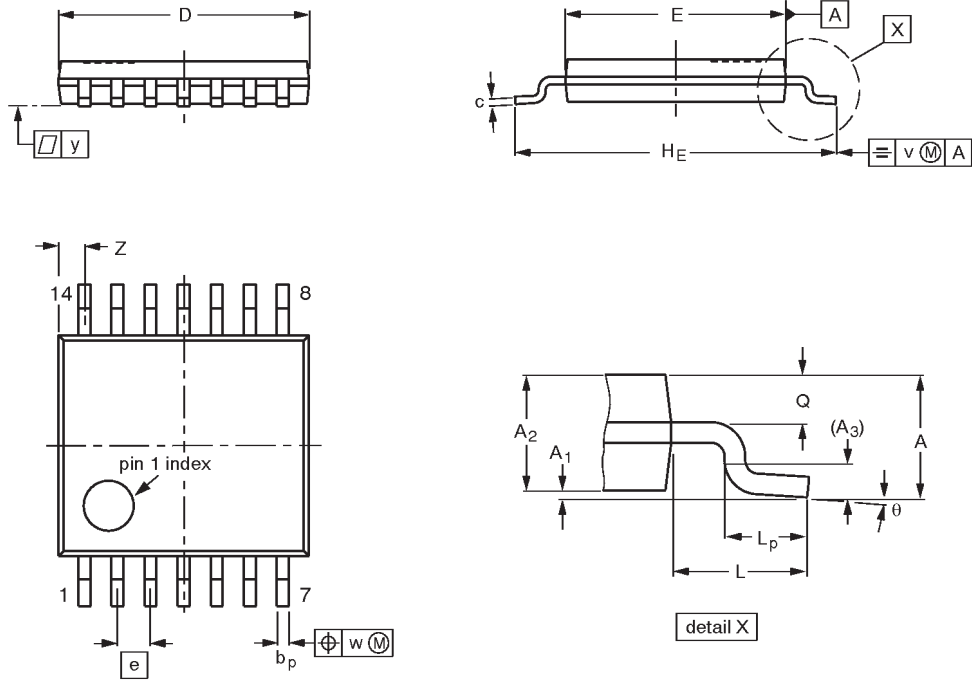

DIMENSIONS (mm are the original dimensions)

UNIT	A max.	A ₁	A ₂	A ₃	b _p	c	D ⁽¹⁾	E ⁽²⁾	e	H _E	L	L _p	Q	v	w	y	z ⁽¹⁾	θ
mm	1.10	0.15 0.05	0.95 0.80	0.25	0.30 0.19	0.2 0.1	5.1 4.9	4.5 4.3	0.65	6.6 6.2	1.0	0.75 0.50	0.4 0.3	0.2	0.13	0.1	0.72 0.38	8° 0°

Notes

1. Plastic or metal protrusions of 0.15 mm maximum per side are not included.
2. Plastic interlead protrusions of 0.25 mm maximum per side are not included.

OUTLINE VERSION	REFERENCES				EUROPEAN PROJECTION	ISSUE DATE
	IEC	JEDEC	EIAJ			
SOT402-1		MO-153				-94-07-12- 95-04-04

Dual D-type flip-flop with set and reset; positive edge-trigger

74LV74

DEFINITIONS

Data Sheet Identification	Product Status	Definition
<i>Objective Specification</i>	Formative or in Design	This data sheet contains the design target or goal specifications for product development. Specifications may change in any manner without notice.
<i>Preliminary Specification</i>	Preproduction Product	This data sheet contains preliminary data, and supplementary data will be published at a later date. Philips Semiconductors reserves the right to make changes at any time without notice in order to improve design and supply the best possible product.
<i>Product Specification</i>	Full Production	This data sheet contains Final Specifications. Philips Semiconductors reserves the right to make changes at any time without notice, in order to improve design and supply the best possible product.

Philips Semiconductors and Philips Electronics North America Corporation reserve the right to make changes, without notice, in the products, including circuits, standard cells, and/or software, described or contained herein in order to improve design and/or performance. Philips Semiconductors assumes no responsibility or liability for the use of any of these products, conveys no license or title under any patent, copyright, or mask work right to these products, and makes no representations or warranties that these products are free from patent, copyright, or mask work right infringement, unless otherwise specified. Applications that are described herein for any of these products are for illustrative purposes only. Philips Semiconductors makes no representation or warranty that such applications will be suitable for the specified use without further testing or modification.

LIFE SUPPORT APPLICATIONS

Philips Semiconductors and Philips Electronics North America Corporation Products are not designed for use in life support appliances, devices, or systems where malfunction of a Philips Semiconductors and Philips Electronics North America Corporation Product can reasonably be expected to result in a personal injury. Philips Semiconductors and Philips Electronics North America Corporation customers using or selling Philips Semiconductors and Philips Electronics North America Corporation Products for use in such applications do so at their own risk and agree to fully indemnify Philips Semiconductors and Philips Electronics North America Corporation for any damages resulting from such improper use or sale.

Philips Semiconductors
811 East Arques Avenue
P.O. Box 3409
Sunnyvale, California 94088-3409
Telephone 800-234-7381

© Copyright Philips Electronics North America Corporation 1998
All rights reserved. Printed in U.S.A.

print code

Date of release: 05-96

Document order number:

9397-750-04414

Let's make things better.



LittleDiode supplies new, hard to find or obsolete electronic components and semiconductors all over the world.

With over two million different components listed you are sure to find the part you need.

Feel free to visit us today at our online store:

LittleDiode.com

Looking forward to providing you with the best possible service.