

74LVC1G3157

2-channel analog multiplexer/demultiplexer

Rev. 01 — 7 February 2005

Product data sheet

1. General description

The 74LVC1G3157 is a high-performance, low-power, low-voltage, Si-gate CMOS device that provides superior performance to most advanced CMOS compatible TTL families.

The 74LVC1G3157 provides one analog multiplexer/demultiplexer with one digital select input (S), two independent inputs/outputs (B1 and B2) and a common input/output (A).

2. Features

- Wide supply voltage range from 1.65 V to 5.5 V
- Very low ON-resistance:
 - ◆ 7.5 Ω (typical) at $V_{CC} = 2.7$ V
 - ◆ 6.5 Ω (typical) at $V_{CC} = 3.3$ V
 - ◆ 6 Ω (typical) at $V_{CC} = 5$ V
- Break-before-make switching
- High noise immunity
- ESD protection:
 - ◆ HBM EIA/JESD22-A114-B exceeds 2000 V
 - ◆ MM EIA/JESD22-A115-A exceeds 200 V
- CMOS low-power consumption
- Latch-up performance meets requirements of JESD 78 Class I
- Direct interface with TTL levels
- Control input accepts voltages up to 5 V
- Multiple package options
- Specified from -40 °C to $+85$ °C and from -40 °C to $+125$ °C

3. Quick reference data

Table 1: Quick reference data

$GND = 0$ V; $t_r = t_f \leq 2.5$ ns; minimum and maximum values at $T_{amb} = -40$ °C to $+85$ °C; typical values at $T_{amb} = 25$ °C.

Symbol	Parameter	Conditions	Min	Typ	Max	Unit
t_{PZH} , t_{PZL}	turn-on time S to Bn	$C_L = 50$ pF; $R_L = 500$ Ω				
		$V_{CC} = 3.3$ V	0.5	4.0	5.5	ns
		$V_{CC} = 5.0$ V	0.5	3.0	4.0	ns
t_{PHZ} , t_{PLZ}	turn-off time S to Bn	$C_L = 50$ pF; $R_L = 500$ Ω				
		$V_{CC} = 3.3$ V	0.5	3.6	4.5	ns
		$V_{CC} = 5.0$ V	0.8	2.9	3.5	ns

PHILIPS

Table 1: Quick reference data ...continued

$GND = 0\text{ V}$; $t_r = t_f \leq 2.5\text{ ns}$; minimum and maximum values at $T_{amb} = -40\text{ }^\circ\text{C}$ to $+85\text{ }^\circ\text{C}$; typical values at $T_{amb} = 25\text{ }^\circ\text{C}$.

Symbol	Parameter	Conditions	Min	Typ	Max	Unit
C_I	select input capacitance		-	2.5	-	pF
C_S	switch capacitance	OFF-state	-	6.0	-	pF
		ON-state	-	18	-	pF

4. Ordering information

Table 2: Ordering information

Type number	Package			
	Temperature range	Name	Description	Version
74LVC1G3157GW	-40 °C to +125 °C	SC-88	plastic surface mounted package; 6 leads	SOT363
74LVC1G3157GV	-40 °C to +125 °C	SC-74	plastic surface mounted package; 6 leads	SOT457
74LVC1G3157GM	-40 °C to +125 °C	XSON6	plastic extremely thin small outline package; no leads; 6 terminals; body 1 × 1.45 × 0.5 mm	SOT886

5. Marking

Table 3: Marking

Type number	Marking code
74LVC1G3157GW	YJ
74LVC1G3157GV	YJ
74LVC1G3157GM	YJ

6. Functional diagram

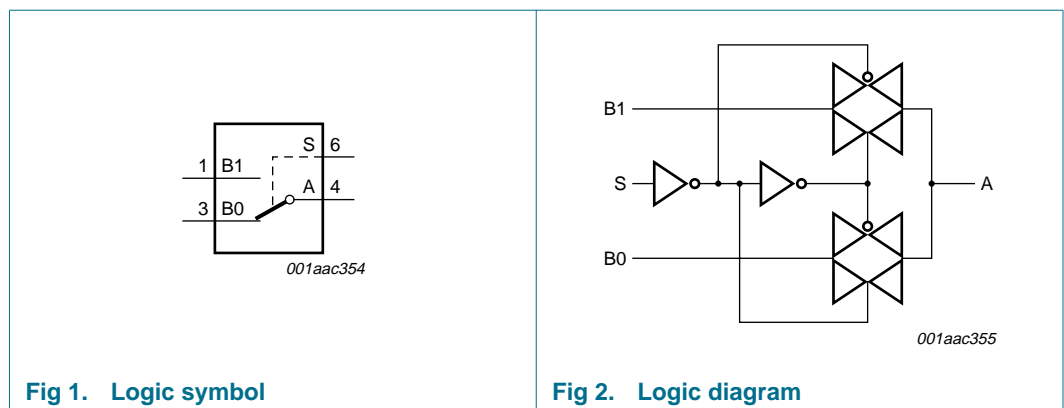

7. Pinning information

7.1 Pinning

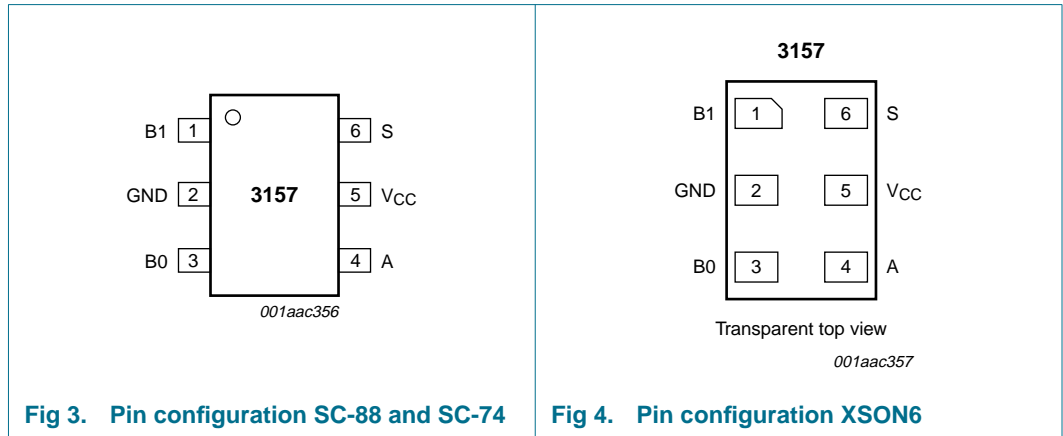

7.2 Pin description

Table 4: Pin description

Symbol	Pin	Description
B1	1	independent B1 input or output
GND	2	ground (0 V)
B0	3	independent B0 input or output
A	4	common A output or input
V _{CC}	5	supply voltage
S	6	select input

8. Functional description

8.1 Function table

Table 5: Function table [1]

Input S	Channel on
L	B0
H	B1

[1] H = HIGH voltage level;
L = LOW voltage level.

9. Limiting values

Table 6: Limiting values

In accordance with the Absolute Maximum Rating System (IEC 60134). Voltages are referenced to GND (ground = 0 V).

Symbol	Parameter	Conditions	Min	Max	Unit
V_{CC}	supply voltage		-0.5	+6.5	V
V_I	input voltage		[1] -0.5	+6.5	V
I_{IK}	input diode current	$V_I < -0.5 \text{ V}$ or $V_I > V_{CC} + 0.5$	-	-50	mA
I_{SK}	switch diode current	$V_I < -0.5 \text{ V}$ or $V_I > V_{CC} + 0.5$	-	± 50	mA
V_S	switch DC voltage	enable and disable mode	-0.5	$V_{CC} + 0.5$	V
I_S	switch source or sink current	$V_S > -0.5 \text{ V}$ or $V_S < V_{CC} + 0.5$	-	± 50	mA
I_{CC}, I_{GND}	V_{CC} or GND current		-	± 100	mA
T_{stg}	storage temperature		-65	+150	°C
P_{tot}	total power dissipation	$T_{amb} = -40 \text{ °C}$ to $+125 \text{ °C}$	-	300	mW

[1] The input and output voltage ratings may be exceeded if the input and output current ratings are observed.

10. Recommended operating conditions

Table 7: Recommended operating conditions

Symbol	Parameter	Conditions	Min	Typ	Max	Unit
V_{CC}	supply voltage		1.65	-	5.5	V
V_I	input voltage		0	-	5.5	V
V_S	switch DC voltage	enable and disable mode	[1] 0	-	V_{CC}	V
T_{amb}	ambient temperature		-40	-	+125	°C
t_r, t_f	input rise and fall times	$V_{CC} = 1.65 \text{ V}$ to 2.7 V	[2] 0	-	20	ns/V
		$V_{CC} = 2.7 \text{ V}$ to 5.5 V	[2] 0	-	10	ns/V

[1] To avoid drawing V_{CC} current out of terminal A when switch current flows in terminal Bn, the voltage drop across the bidirectional switch must not exceed 0.4 V. If the switch current flows into terminal A, no V_{CC} current will flow out of terminal Bn. In this case, there is no limit for the voltage drop across the switch.

[2] Applies to control signal levels.

11. Static characteristics

Table 8: Static characteristics

At recommended operating conditions; voltages are referenced to GND (ground 0 V).

Symbol	Parameter	Conditions	Min	Typ	Max	Unit
$T_{amb} = -40 \text{ °C}$ to $+85 \text{ °C}$ [1]						
V_{IH}	HIGH-level input voltage	$V_{CC} = 1.65 \text{ V}$ to 1.95 V	$0.65V_{CC}$	-	-	V
		$V_{CC} = 2.3 \text{ V}$ to 2.7 V	1.7	-	-	V
		$V_{CC} = 3 \text{ V}$ to 3.6 V	2.0	-	-	V
		$V_{CC} = 4.5 \text{ V}$ to 5.5 V	$0.7V_{CC}$	-	-	V

Table 8: Static characteristics ...continued
 At recommended operating conditions; voltages are referenced to GND (ground 0 V).

Symbol	Parameter	Conditions	Min	Typ	Max	Unit
V _{IL}	LOW-level input voltage	V _{CC} = 1.65 V to 1.95 V	-	-	0.35V _{CC}	V
		V _{CC} = 2.3 V to 2.7 V	-	-	0.7	V
		V _{CC} = 3 V to 3.6 V	-	-	0.8	V
		V _{CC} = 4.5 V to 5.5 V	-	-	0.3V _{CC}	V
I _{LI}	input leakage current on pin S	V _I = 5.5 V or GND; V _{CC} = 5.5 V	-	±0.1	±2	µA
I _{S(OFF)}	analog switch OFF-state current per channel	V _I = V _{IH} or V _{IL} ; V _{SI} = V _{CC} - GND; V _{CC} = 5.5 V; see Figure 5	-	±0.1	±5	µA
I _{S(ON)}	analog switch ON-state current per channel	V _I = V _{IH} or V _{IL} ; V _{SI} = V _{CC} - GND; V _{CC} = 5.5 V; see Figure 6	-	±0.1	±5	µA
I _{CC}	quiescent supply current	V _I = V _{CC} or GND; V _S = GND or V _{CC} ; I _O = 0 A; V _{CC} = 5.5 V	-	0.1	10	µA
ΔI _{CC}	additional quiescent supply current pin S	V _I = V _{CC} - 0.6 V; V _S = GND or V _{CC} ; I _O = 0 A; V _{CC} = 5.5 V	-	5	500	µA
C _I	input capacitance		-	2.5	-	pF
C _S	switch capacitance	OFF-state	-	6.0	-	pF
		ON-state	-	18	-	pF
T_{amb} = -40 °C to +125 °C						
V _{IH}	HIGH-level input voltage	V _{CC} = 1.65 V to 1.95 V	0.65V _{CC}	-	-	V
		V _{CC} = 2.3 V to 2.7 V	1.7	-	-	V
		V _{CC} = 3 V to 3.6 V	2.0	-	-	V
		V _{CC} = 4.5 V to 5.5 V	0.7V _{CC}	-	-	
V _{IL}	LOW-level input voltage	V _{CC} = 1.65 V to 1.95 V	-	-	0.35V _{CC}	V
		V _{CC} = 2.3 V to 2.7 V	-	-	0.7	V
		V _{CC} = 3 V to 3.6 V	-	-	0.8	V
		V _{CC} = 4.5 V to 5.5 V	-	-	0.3V _{CC}	V
I _{LI}	input leakage current on pin S	V _I = 5.5 V or GND; V _{CC} = 5.5 V	-	-	±10	µA
I _{S(OFF)}	analog switch OFF-state current per channel	V _I = V _{IH} or V _{IL} ; V _{SI} = V _{CC} - GND; V _{CC} = 5.5 V; see Figure 5	-	-	±20	µA
I _{S(ON)}	analog switch ON-state current per channel	V _I = V _{IH} or V _{IL} ; V _{SI} = V _{CC} - GND; V _{CC} = 5.5 V; see Figure 6	-	-	±20	µA
I _{CC}	quiescent supply current	V _I = V _{CC} or GND; V _S = GND or V _{CC} ; I _O = 0 A; V _{CC} = 5.5 V	-	-	40	µA
ΔI _{CC}	additional quiescent supply current pin S	V _I = V _{CC} - 0.6 V; V _S = GND or V _{CC} ; I _O = 0 A; V _{CC} = 5.5 V	-	-	5000	µA

[1] Typical values are measured at T_{amb} = 25 °C.

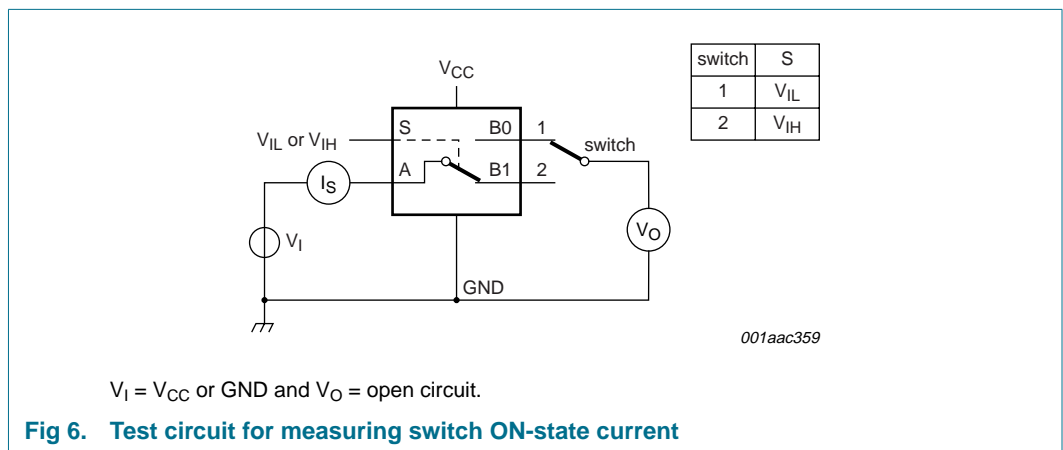
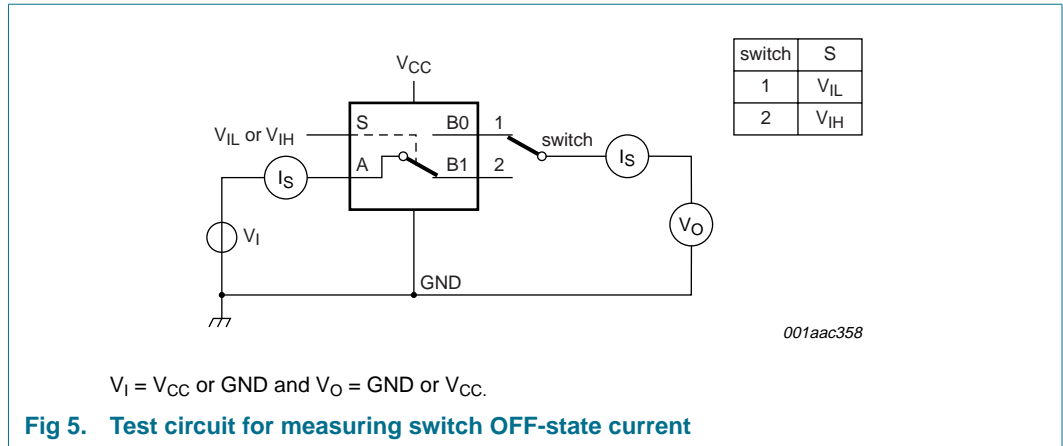

Table 9: Resistance R_{ON}

At recommended operating conditions; voltages are referenced to GND (ground = 0 V); see test circuit [Figure 7](#).

Symbol	Parameter	Conditions	Min	Typ	Max	Unit	
$T_{amb} = -40\text{ }^{\circ}\text{C}$ to $+85\text{ }^{\circ}\text{C}$ [1]							
$R_{ON(rail)}$	switch ON-state resistance (rail)	$V_S = GND; V_I = V_{IH}$					
		$I_S = 4\text{ mA}; V_{CC} = 1.65\text{ V to }1.95\text{ V}$	-	8.7	18	Ω	
		$I_S = 8\text{ mA}; V_{CC} = 2.3\text{ V to }2.7\text{ V}$	-	7.2	16	Ω	
		$I_S = 12\text{ mA}; V_{CC} = 2.7\text{ V}$	-	7.0	14	Ω	
		$I_S = 24\text{ mA}; V_{CC} = 3\text{ V to }3.6\text{ V}$	-	6.5	12	Ω	
		$I_S = 32\text{ mA}; V_{CC} = 4.5\text{ V to }5.5\text{ V}$	-	5.9	10	Ω	
		$V_S = V_{CC}; V_I = V_{IH}$					
		$I_S = 4\text{ mA}; V_{CC} = 1.65\text{ V to }1.95\text{ V}$	-	12	30	Ω	
		$I_S = 8\text{ mA}; V_{CC} = 2.3\text{ V to }2.7\text{ V}$	-	8.3	20	Ω	
		$I_S = 12\text{ mA}; V_{CC} = 2.7\text{ V}$	-	7.8	18	Ω	
		$I_S = 24\text{ mA}; V_{CC} = 3\text{ V to }3.6\text{ V}$	-	6.7	15	Ω	
		$I_S = 32\text{ mA}; V_{CC} = 4.5\text{ V to }5.5\text{ V}$	-	5.2	10	Ω	

Table 9: Resistance R_{ON} ...continuedAt recommended operating conditions; voltages are referenced to GND (ground = 0 V); see test circuit [Figure 7](#).

Symbol	Parameter	Conditions	Min	Typ	Max	Unit	
$R_{ON(peak)}$	switch ON-state resistance (peak)	$V_S = \text{GND to } V_{CC}; V_I = V_{IH}$					
		$I_S = 4 \text{ mA}; V_{CC} = 1.65 \text{ V to } 1.95 \text{ V}$	-	57	140	Ω	
		$I_S = 8 \text{ mA}; V_{CC} = 2.3 \text{ V to } 2.7 \text{ V}$	-	15	40	Ω	
		$I_S = 12 \text{ mA}; V_{CC} = 2.7 \text{ V}$	-	13	25	Ω	
		$I_S = 24 \text{ mA}; V_{CC} = 3 \text{ V to } 3.6 \text{ V}$	-	9.0	20	Ω	
		$I_S = 32 \text{ mA}; V_{CC} = 4.5 \text{ V to } 5.5 \text{ V}$	-	6.0	15	Ω	
$R_{ON(flatness)}$	switch ON-resistance (flatness)	$V_S = \text{GND to } V_{CC}; V_I = V_{IH}$; see Figure 9					
		$I_S = 4 \text{ mA}; V_{CC} = 1.65 \text{ V to } 1.95 \text{ V}$	-	100	-	Ω	
		$I_S = 8 \text{ mA}; V_{CC} = 2.3 \text{ V to } 2.7 \text{ V}$	-	17	-	Ω	
		$I_S = 12 \text{ mA}; V_{CC} = 2.7 \text{ V}$	-	10	-	Ω	
		$I_S = 24 \text{ mA}; V_{CC} = 3 \text{ V to } 3.6 \text{ V}$	-	5	-	Ω	
		$I_S = 32 \text{ mA}; V_{CC} = 4.5 \text{ V to } 5.5 \text{ V}$	-	3	-	Ω	
$T_{amb} = -40 \text{ }^\circ\text{C to } +125 \text{ }^\circ\text{C}$							
$R_{ON(rail)}$	switch ON-state resistance (rail)	$V_S = \text{GND}; V_I = V_{IH}$					
		$I_S = 4 \text{ mA}; V_{CC} = 1.65 \text{ V to } 1.95 \text{ V}$	-	-	27	Ω	
		$I_S = 8 \text{ mA}; V_{CC} = 2.3 \text{ V to } 2.7 \text{ V}$	-	-	24	Ω	
		$I_S = 12 \text{ mA}; V_{CC} = 2.7 \text{ V}$	-	-	21	Ω	
		$I_S = 24 \text{ mA}; V_{CC} = 3 \text{ V to } 3.6 \text{ V}$	-	-	18	Ω	
		$I_S = 32 \text{ mA}; V_{CC} = 4.5 \text{ V to } 5.5 \text{ V}$	-	-	15	Ω	
		$V_S = V_{CC}; V_I = V_{IH}$					
		$I_S = 4 \text{ mA}; V_{CC} = 1.65 \text{ V to } 1.95 \text{ V}$	-	-	45	Ω	
		$I_S = 8 \text{ mA}; V_{CC} = 2.3 \text{ V to } 2.7 \text{ V}$	-	-	30	Ω	
		$I_S = 12 \text{ mA}; V_{CC} = 2.7 \text{ V}$	-	-	27	Ω	
		$I_S = 24 \text{ mA}; V_{CC} = 3 \text{ V to } 3.6 \text{ V}$	-	-	23	Ω	
		$I_S = 32 \text{ mA}; V_{CC} = 4.5 \text{ V to } 5.5 \text{ V}$	-	-	15	Ω	
$R_{ON(peak)}$	switch ON-state resistance (peak)	$V_S = \text{GND to } V_{CC}; V_I = V_{IH}$					
		$I_S = 4 \text{ mA}; V_{CC} = 1.65 \text{ V to } 1.95 \text{ V}$	-	-	140	Ω	
		$I_S = 8 \text{ mA}; V_{CC} = 2.3 \text{ V to } 2.7 \text{ V}$	-	-	60	Ω	
		$I_S = 12 \text{ mA}; V_{CC} = 2.7 \text{ V}$	-	-	38	Ω	
		$I_S = 24 \text{ mA}; V_{CC} = 3 \text{ V to } 3.6 \text{ V}$	-	-	30	Ω	
		$I_S = 32 \text{ mA}; V_{CC} = 4.5 \text{ V to } 5.5 \text{ V}$	-	-	23	Ω	

[1] Typical values are measured at $T_{amb} = 25 \text{ }^\circ\text{C}$ and nominal V_{CC} .

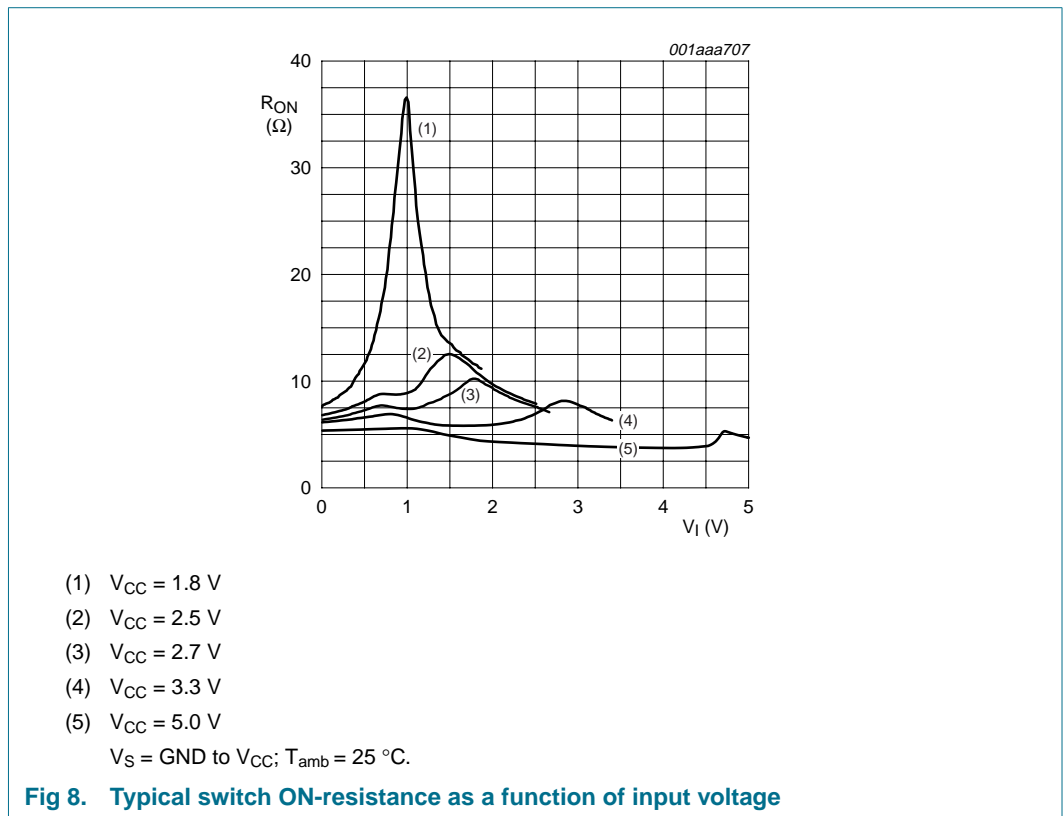
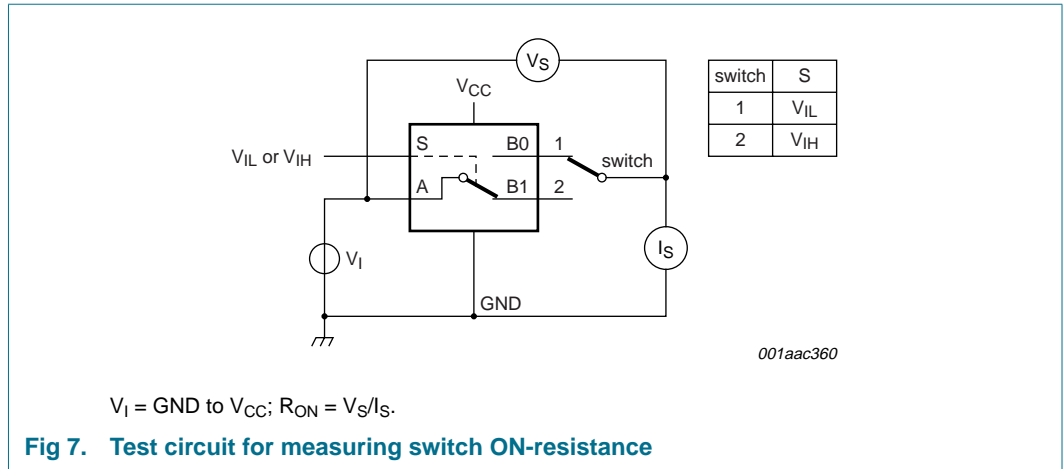

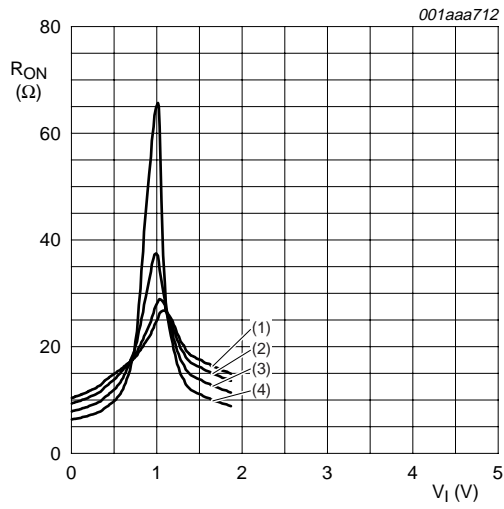

- (1) $T_{amb} = 125\text{ °C}$
 - (2) $T_{amb} = 85\text{ °C}$
 - (3) $T_{amb} = 25\text{ °C}$
 - (4) $T_{amb} = -40\text{ °C}$
- a. $V_{CC} = 1.8\text{ V}$

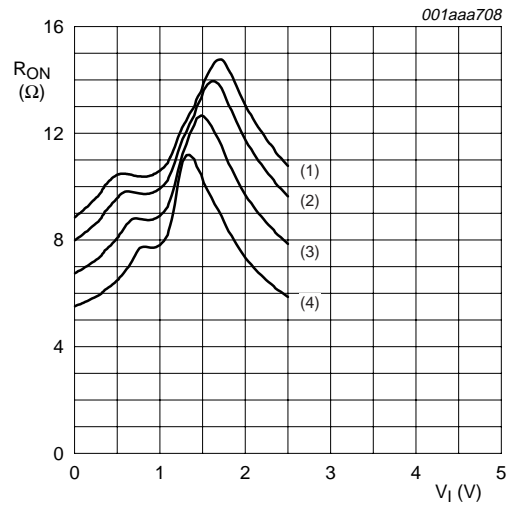

- (1) $T_{amb} = 125\text{ °C}$
 - (2) $T_{amb} = 85\text{ °C}$
 - (3) $T_{amb} = 25\text{ °C}$
 - (4) $T_{amb} = -40\text{ °C}$
- b. $V_{CC} = 2.5\text{ V}$

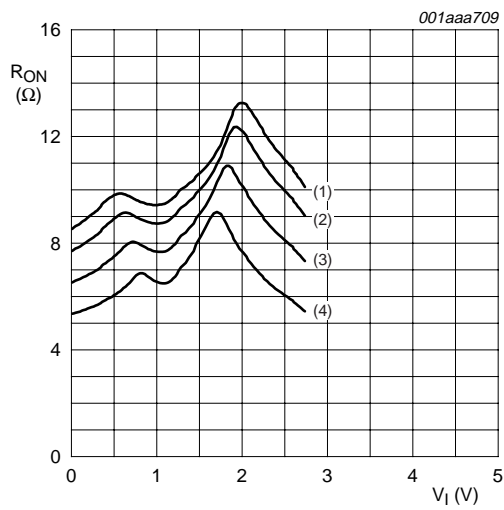

- (1) $T_{amb} = 125\text{ °C}$
 - (2) $T_{amb} = 85\text{ °C}$
 - (3) $T_{amb} = 25\text{ °C}$
 - (4) $T_{amb} = -40\text{ °C}$
- c. $V_{CC} = 2.7\text{ V}$

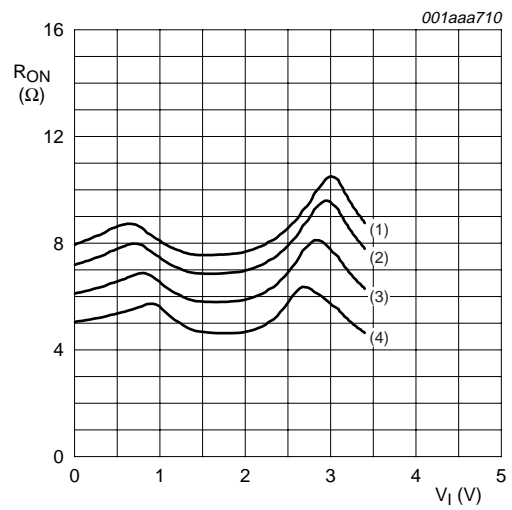

- (1) $T_{amb} = 125\text{ °C}$
 - (2) $T_{amb} = 85\text{ °C}$
 - (3) $T_{amb} = 25\text{ °C}$
 - (4) $T_{amb} = -40\text{ °C}$
- d. $V_{CC} = 3.3\text{ V}$

Fig 9. Switch ON-resistance as a function of input voltage

12. Dynamic characteristics

Table 10: Dynamic characteristics

At recommended operating conditions; voltages are referenced to GND (ground = 0 V); test circuit [Figure 13](#).

Symbol	Parameter	Conditions	Min	Typ	Max	Unit
$T_{amb} = -40\text{ °C to }+85\text{ °C}$ [1]						
t_{PHL} , t_{PLH}	propagation delay A to Bn or Bn to A	see Figure 10				
		$V_{CC} = 1.65\text{ V to }1.95\text{ V}$	-	-	2	ns
		$V_{CC} = 2.3\text{ V to }2.7\text{ V}$	-	-	1.2	ns
		$V_{CC} = 2.7\text{ V}$	-	-	1.0	ns
		$V_{CC} = 3\text{ V to }3.6\text{ V}$	-	-	0.8	ns
		$V_{CC} = 4.5\text{ V to }5.5\text{ V}$	-	-	0.6	ns
t_{PZH} , t_{PZL}	turn-on time S to Bn	see Figure 11				
		$V_{CC} = 1.65\text{ V to }1.95\text{ V}$	1.0	8.7	14	ns
		$V_{CC} = 2.3\text{ V to }2.7\text{ V}$	1.0	5.3	7.5	ns
		$V_{CC} = 2.7\text{ V}$	1.0	4.9	6.0	ns
		$V_{CC} = 3\text{ V to }3.6\text{ V}$	0.5	4.0	5.5	ns
		$V_{CC} = 4.5\text{ V to }5.5\text{ V}$	0.5	3.0	4.0	ns
t_{PHZ} , t_{PLZ}	turn-off time S to Bn	see Figure 11				
		$V_{CC} = 1.65\text{ V to }1.95\text{ V}$	2.5	6.0	8.5	ns
		$V_{CC} = 2.3\text{ V to }2.7\text{ V}$	2.0	4.4	6.0	ns
		$V_{CC} = 2.7\text{ V}$	1.5	4.2	5.0	ns
		$V_{CC} = 3\text{ V to }3.6\text{ V}$	1.5	3.6	4.5	ns
		$V_{CC} = 4.5\text{ V to }5.5\text{ V}$	0.8	2.9	3.5	ns
t_D	break-before-make time	see Figure 12 [2]				
		$V_{CC} = 1.65\text{ V to }1.95\text{ V}$	0.5	-	-	ns
		$V_{CC} = 2.3\text{ V to }2.7\text{ V}$	0.5	-	-	ns
		$V_{CC} = 2.7\text{ V}$	0.5	-	-	ns
		$V_{CC} = 3\text{ V to }3.6\text{ V}$	0.5	-	-	ns
		$V_{CC} = 4.5\text{ V to }5.5\text{ V}$	0.5	-	-	ns
$T_{amb} = -40\text{ °C to }+125\text{ °C}$						
t_{PHL} , t_{PLH}	propagation delay A to Bn or Bn to A	see Figure 10				
		$V_{CC} = 1.65\text{ V to }1.95\text{ V}$	-	-	3.0	ns
		$V_{CC} = 2.3\text{ V to }2.7\text{ V}$	-	-	2.0	ns
		$V_{CC} = 2.7\text{ V}$	-	-	1.5	ns
		$V_{CC} = 3\text{ V to }3.6\text{ V}$	-	-	1.5	ns
		$V_{CC} = 4.5\text{ V to }5.5\text{ V}$	-	-	1.0	ns

Table 10: Dynamic characteristics ...continued

At recommended operating conditions; voltages are referenced to GND (ground = 0 V); test circuit [Figure 13](#).

Symbol	Parameter	Conditions	Min	Typ	Max	Unit
t _{PZH} , t _{PZL}	turn-on time S to Bn	see Figure 11				
		V _{CC} = 1.65 V to 1.95 V	1.0	-	14.0	ns
		V _{CC} = 2.3 V to 2.7 V	1.0	-	7.5	ns
		V _{CC} = 2.7 V	1.0	-	6.0	ns
		V _{CC} = 3 V to 3.6 V	0.5	-	5.5	ns
		V _{CC} = 4.5 V to 5.5 V	0.5		4.0	ns
t _{PHZ} , t _{PLZ}	turn-off time S to Bn	see Figure 11				
		V _{CC} = 1.65 V to 1.95 V	2.5	-	8.5	ns
		V _{CC} = 2.3 V to 2.7 V	2.0	-	6.0	ns
		V _{CC} = 2.7 V	1.5	-	5.0	ns
		V _{CC} = 3 V to 3.6 V	1.5	-	4.5	ns
		V _{CC} = 4.5 V to 5.5 V	0.8	-	3.5	ns
t _D	break-before-make time	see Figure 12		[2]		
		V _{CC} = 1.65 V to 1.95 V	0.5	-	-	ns
		V _{CC} = 2.3 V to 2.7 V	0.5	-	-	ns
		V _{CC} = 2.7 V	0.5	-	-	ns
		V _{CC} = 3 V to 3.6 V	0.5	-	-	ns
		V _{CC} = 4.5 V to 5.5 V	0.5	-	-	ns

[1] Typical values are measured at T_{amb} = 25 °C and nominal V_{CC}.

[2] Break-before-make specified by design.

13. Waveforms

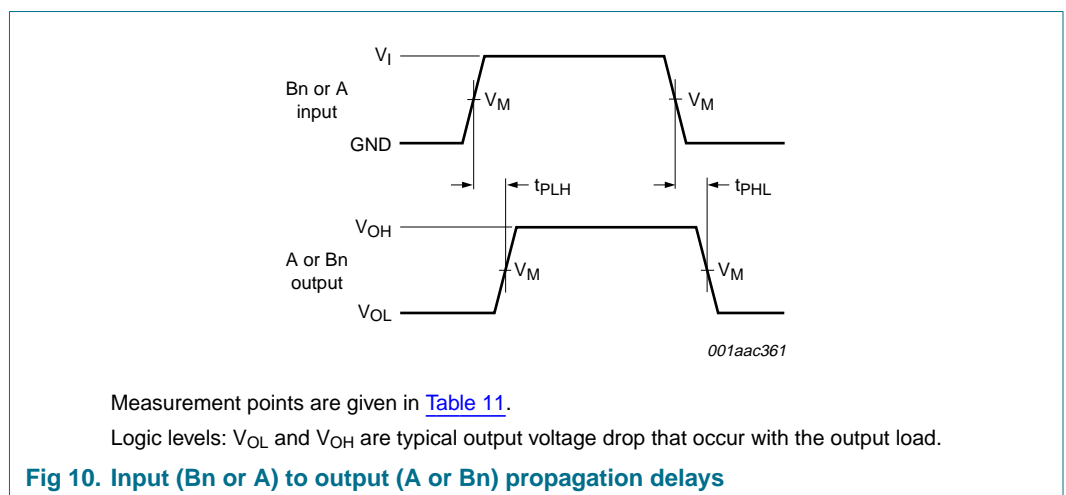

Table 11: Measurement points

Supply voltage	Input	Output
V_{CC}	V_M	V_M
1.65 V to 5.5 V	$0.5V_{CC}$	$0.5V_{CC}$

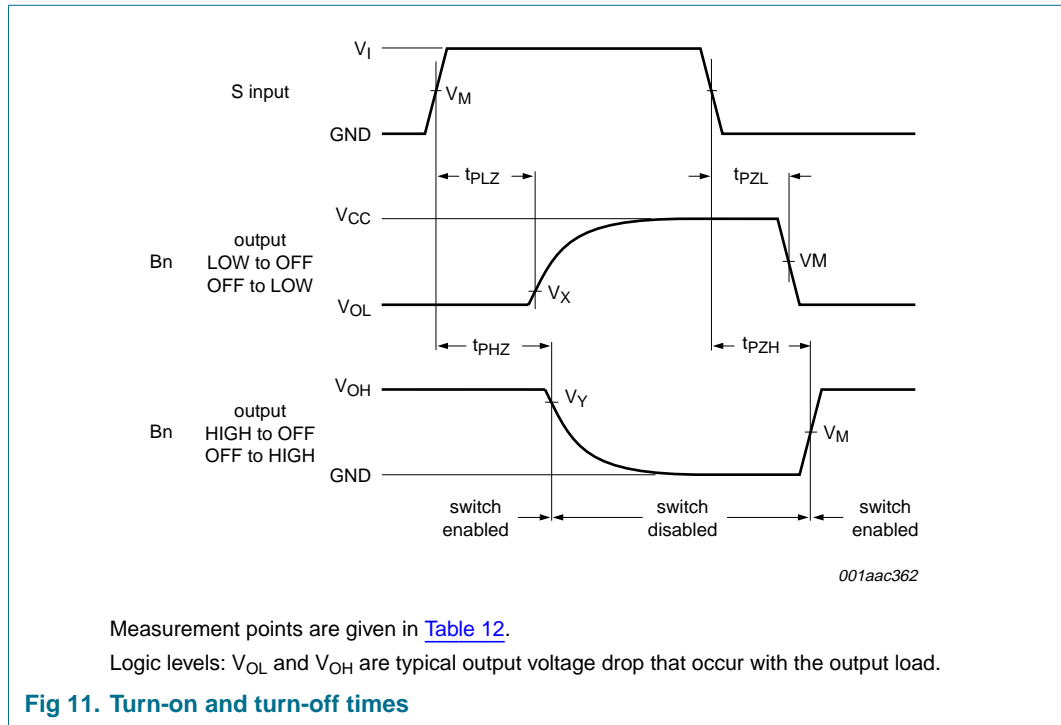

Table 12: Measurement points

Supply voltage	Input	Output		
V_{CC}	V_M	V_M	V_X	V_Y
1.65 V to 5.5 V	$0.5V_{CC}$	$0.5V_{CC}$	$V_{OL} + 0.3 V$	$V_{OH} - 0.3 V$

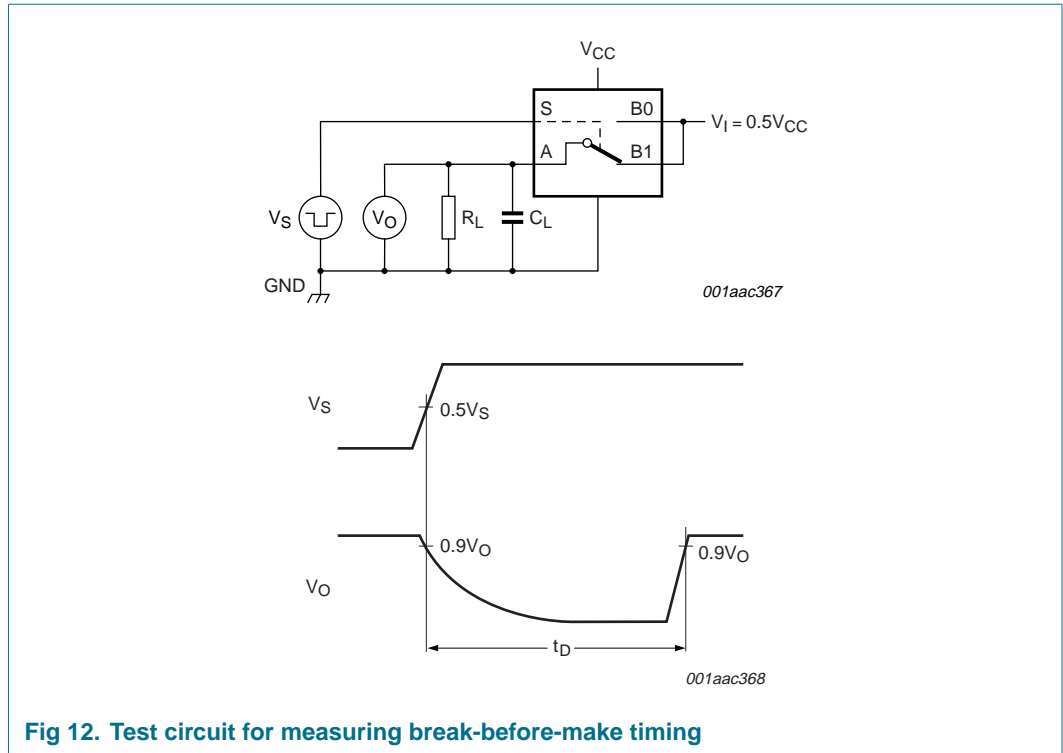

Fig 12. Test circuit for measuring break-before-make timing

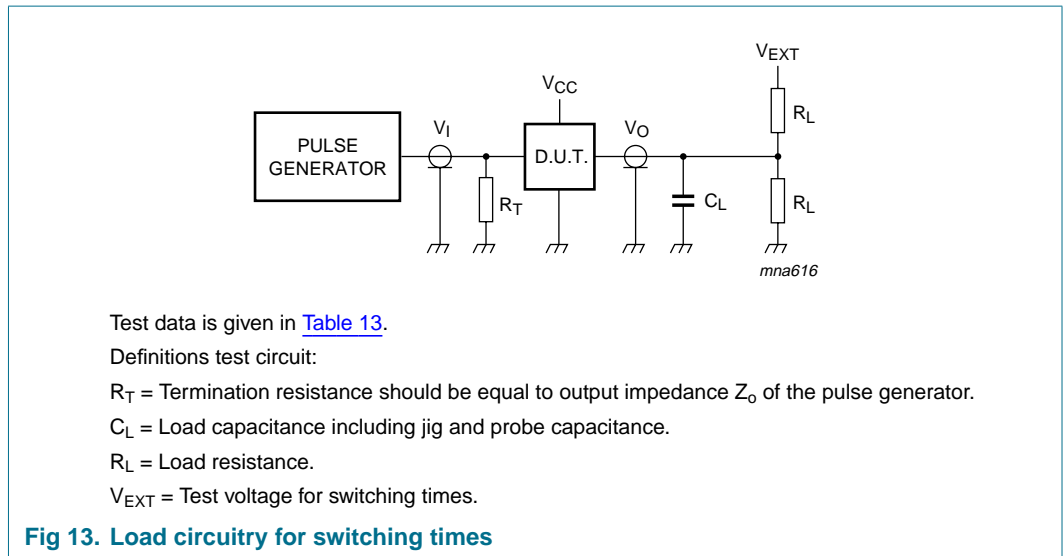

Fig 13. Load circuitry for switching times

Table 13: Test data

Supply voltage	Input	Load			V_{EXT}		
V_{CC}	V_I	t_r, t_f	C_L	R_L	t_{PLH}, t_{PHL}	t_{PZH}, t_{PHZ}	t_{PZL}, t_{PLZ}
1.65 V to 1.95 V	V_{CC}	≤ 2.0 ns	50 pF	500 Ω	open	GND	$2V_{CC}$
2.3 V to 2.7 V	V_{CC}	≤ 2.0 ns	50 pF	500 Ω	open	GND	$2V_{CC}$
2.7 V	V_{CC}	≤ 2.5 ns	50 pF	500 Ω	open	GND	$2V_{CC}$
3 V to 3.6 V	V_{CC}	≤ 2.5 ns	50 pF	500 Ω	open	GND	$2V_{CC}$
4.5 V to 5.5 V	V_{CC}	≤ 2.5 ns	50 pF	500 Ω	open	GND	$2V_{CC}$

14. Additional dynamic characteristics

Table 14: Additional dynamic characteristics

At recommended operating conditions; typical values measured at $T_{amb} = 25\text{ }^{\circ}\text{C}$.

Symbol	Parameter	Conditions	Min	Typ	Max	Unit
d_{sin}	sine-wave distortion	$f_i = 600\text{ Hz to } 20\text{ kHz}; R_L = 600\text{ }\Omega;$ $C_L = 50\text{ pF}; V_I = 0.5\text{ V (p-p);}$ see Figure 14				
		$V_{CC} = 1.65\text{ V}$	-	0.260	-	%
		$V_{CC} = 2.3\text{ V}$	-	0.078	-	%
		$V_{CC} = 3.0\text{ V}$	-	0.078	-	%
		$V_{CC} = 4.5\text{ V}$	-	0.078	-	%
$f_{(-3dB)}$	switch ON-state signal frequency response	$R_L = 50\text{ }\Omega; C_L = 5\text{ pF};$ see Figure 15 ^[1]				
		$V_{CC} = 1.65\text{ V}$	-	200	-	MHz
		$V_{CC} = 2.3\text{ V}$	-	300	-	MHz
		$V_{CC} = 3.0\text{ V}$	-	300	-	MHz
		$V_{CC} = 4.5\text{ V}$	-	300	-	MHz
$\alpha_{OFF(ft)}$	switch OFF-state signal feed-through attenuation	$R_L = 50\text{ }\Omega; C_L = 5\text{ pF}; f_i = 10\text{ MHz};$ see Figure 16 ^[2]				
		$V_{CC} = 1.65\text{ V}$	-	-42	-	dB
		$V_{CC} = 2.3\text{ V}$	-	-42	-	dB
		$V_{CC} = 3.0\text{ V}$	-	-40	-	dB
		$V_{CC} = 4.5\text{ V}$	-	-40	-	dB
$V_{ct(sw-sw)}$	crosstalk between switches	$R_L = 50\text{ }\Omega; C_L = 5\text{ pF}; f_i = 10\text{ MHz};$ see Figure 17				
		$V_{CC} = 1.65\text{ V}$	-	-68	-	dB
		$V_{CC} = 2.3\text{ V}$	-	-70	-	dB
		$V_{CC} = 3.0\text{ V}$	-	-70	-	dB
		$V_{CC} = 4.5\text{ V}$	-	-70	-	dB
Q	charge injection	$C_L = 0.1\text{ nF}; V_{gen} = 0\text{ V}; R_{gen} = 0\text{ }\Omega;$ $f = 1\text{ MHz}; R_L = 1\text{ M}\Omega;$ see Figure 18 ^[3]				
		$V_{CC} = 1.8\text{ V}$	-	< 0.003	-	pC
		$V_{CC} = 2.5\text{ V}$	-	0.004	-	pC
		$V_{CC} = 3.3\text{ V}$	-	0.0045	-	pC
		$V_{CC} = 4.5\text{ V}$	-	0.0045	-	pC
		$V_{CC} = 5.5\text{ V}$	-	0.0045	-	pC

[1] Adjust f_i voltage to obtain 0 dBm level at output. Increase f_i frequency until dB meter reads -3 dB.

[2] Adjust f_i voltage to obtain 0 dBm level at input.

[3] Definition: $Q = \Delta V_O \times C_L$. Guaranteed by design.

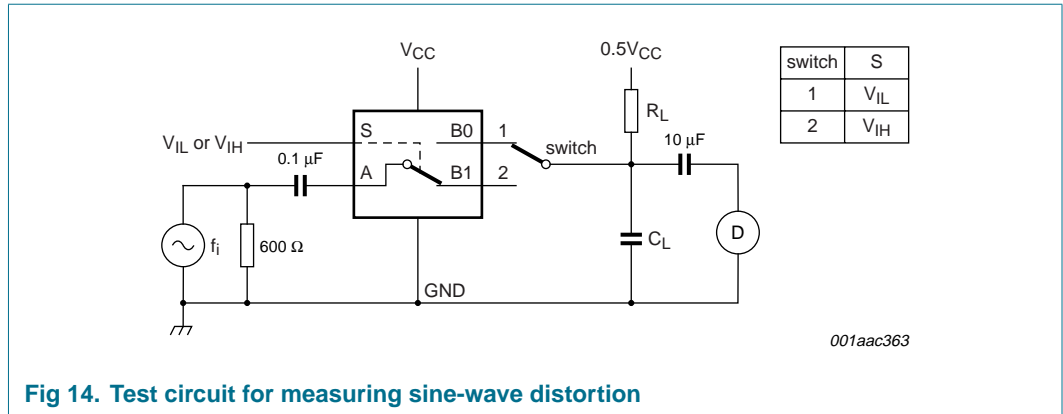

Fig 14. Test circuit for measuring sine-wave distortion

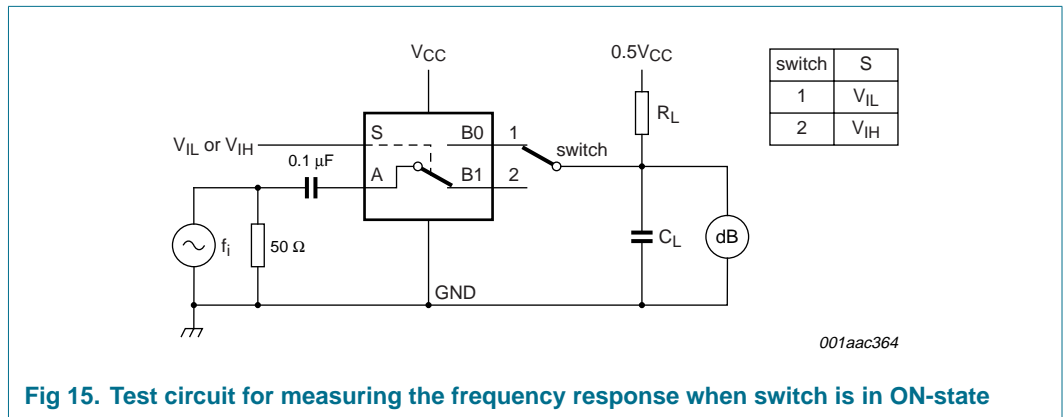

Fig 15. Test circuit for measuring the frequency response when switch is in ON-state

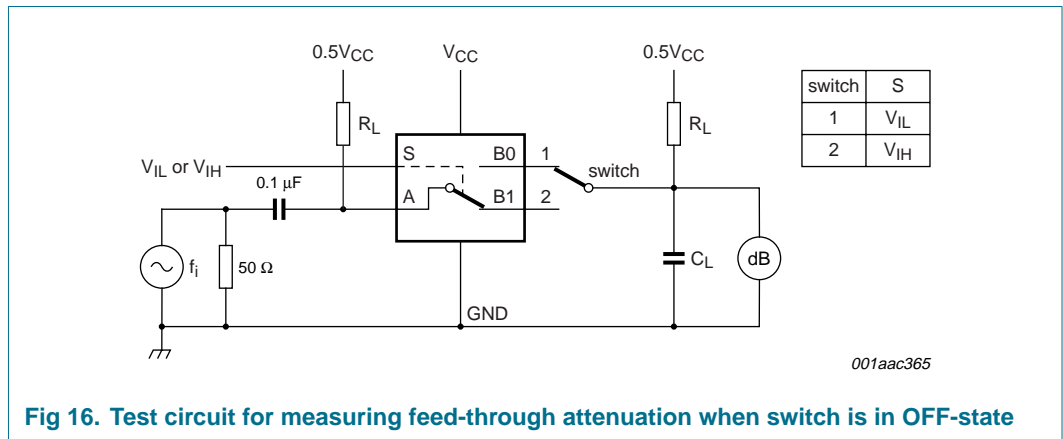

Fig 16. Test circuit for measuring feed-through attenuation when switch is in OFF-state

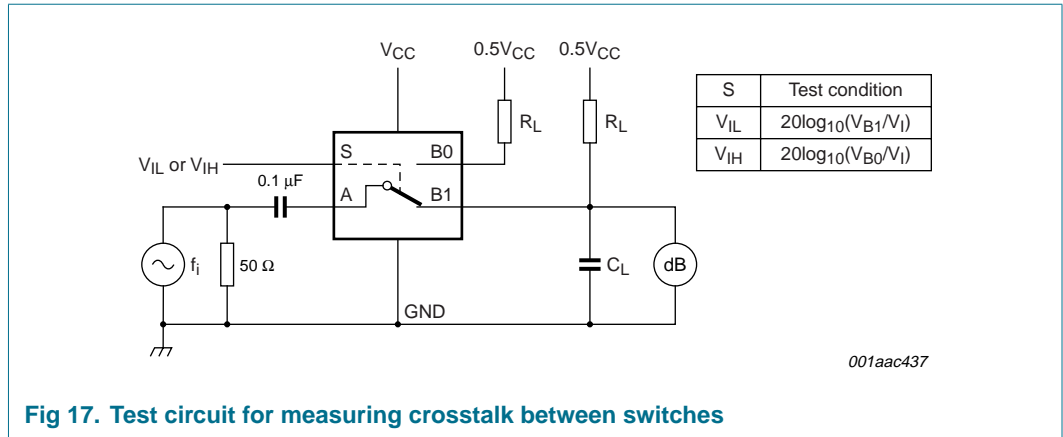

Fig 17. Test circuit for measuring crosstalk between switches

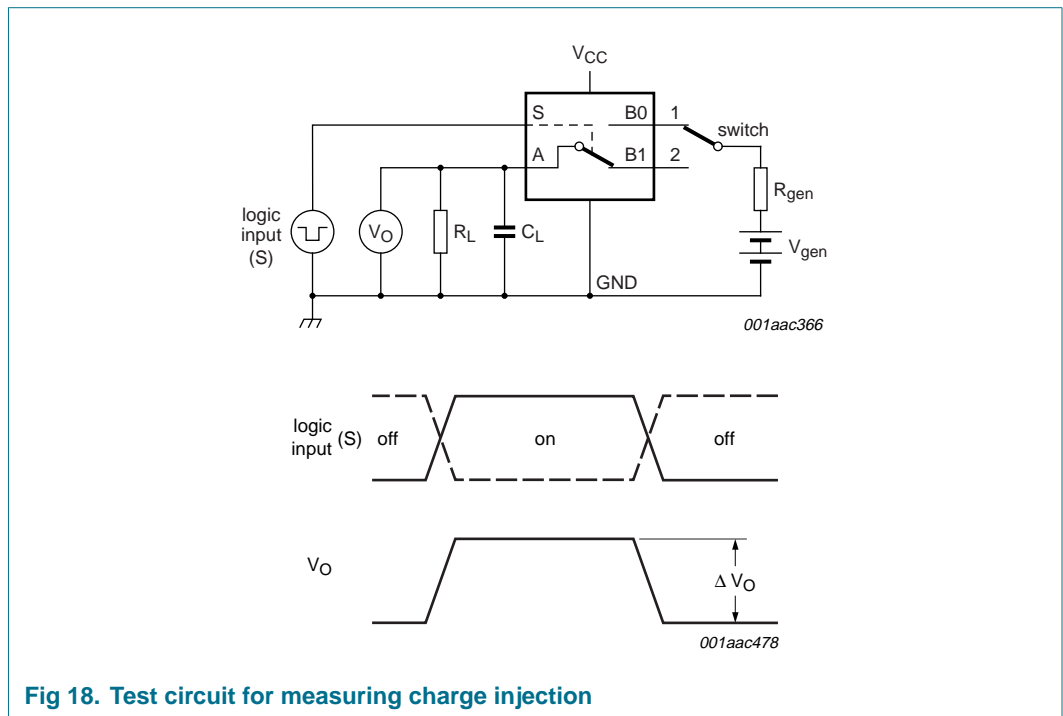

Fig 18. Test circuit for measuring charge injection

15. Package outline

Plastic surface mounted package; 6 leads

SOT363

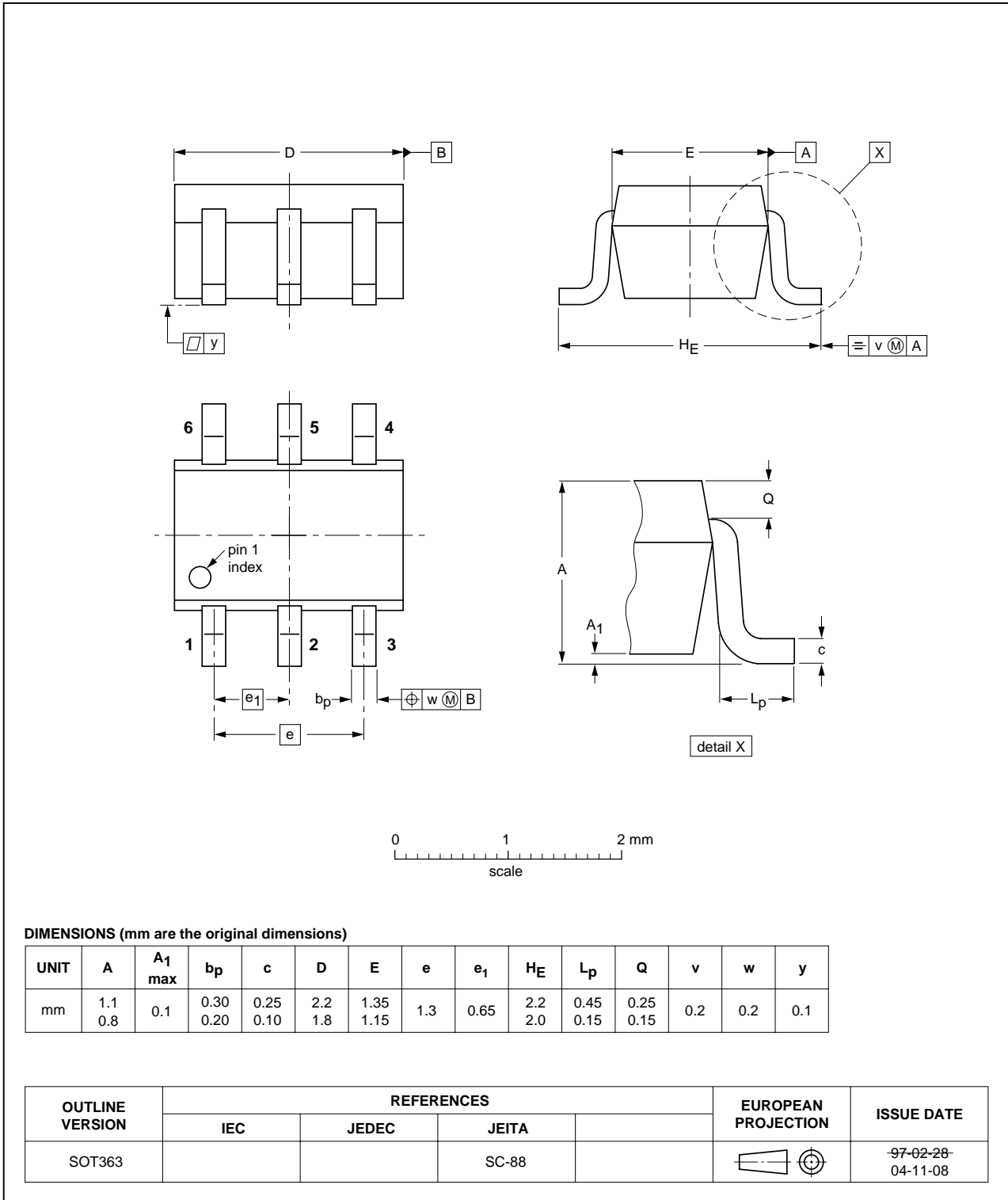

Fig 19. Package outline SOT363 (SC-88)

Plastic surface mounted package; 6 leads

SOT457

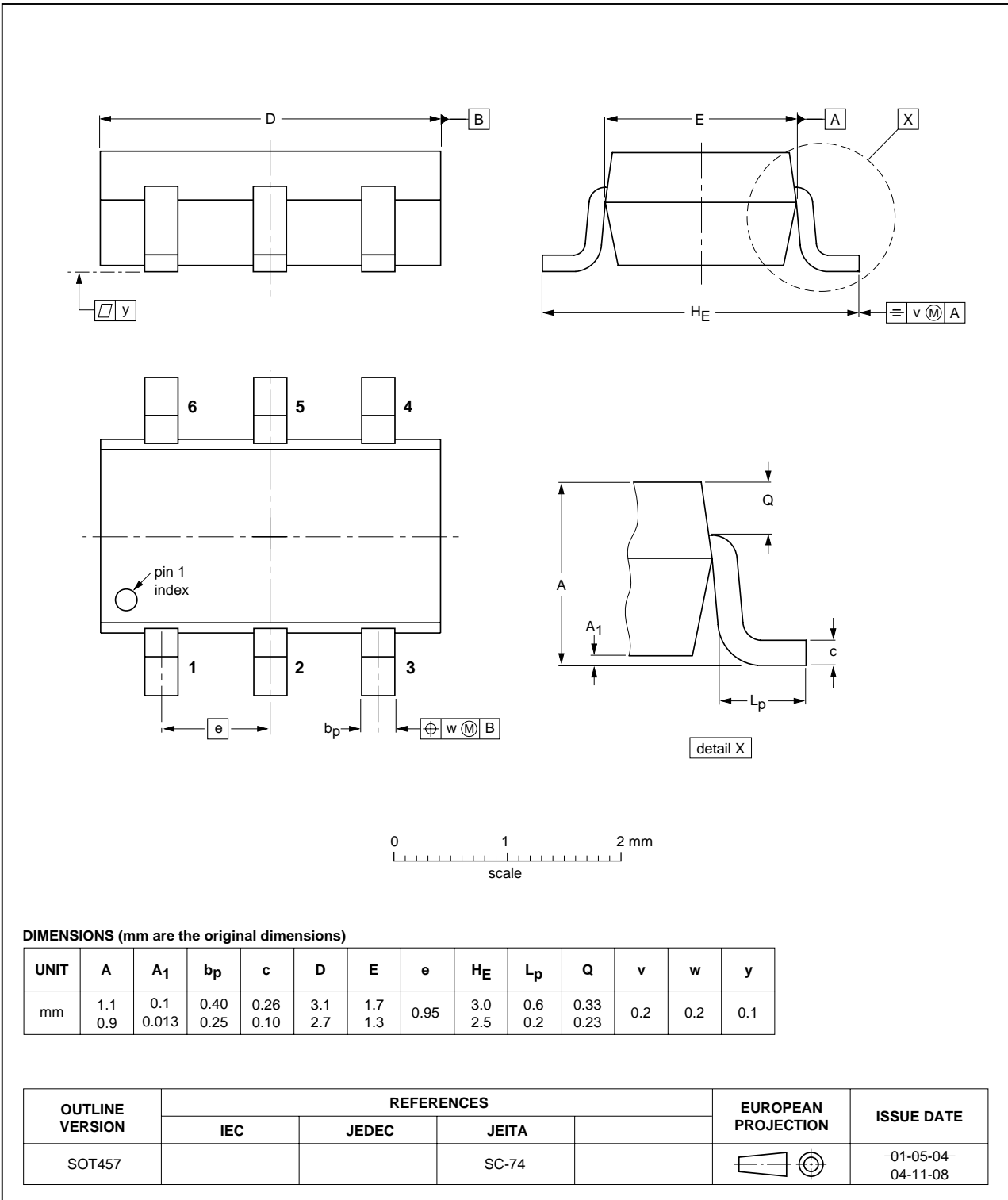

Fig 20. Package outline SOT457 (SC-74)

XSON6: plastic extremely thin small outline package; no leads; 6 terminals; body 1 x 1.45 x 0.5 mm

SOT886

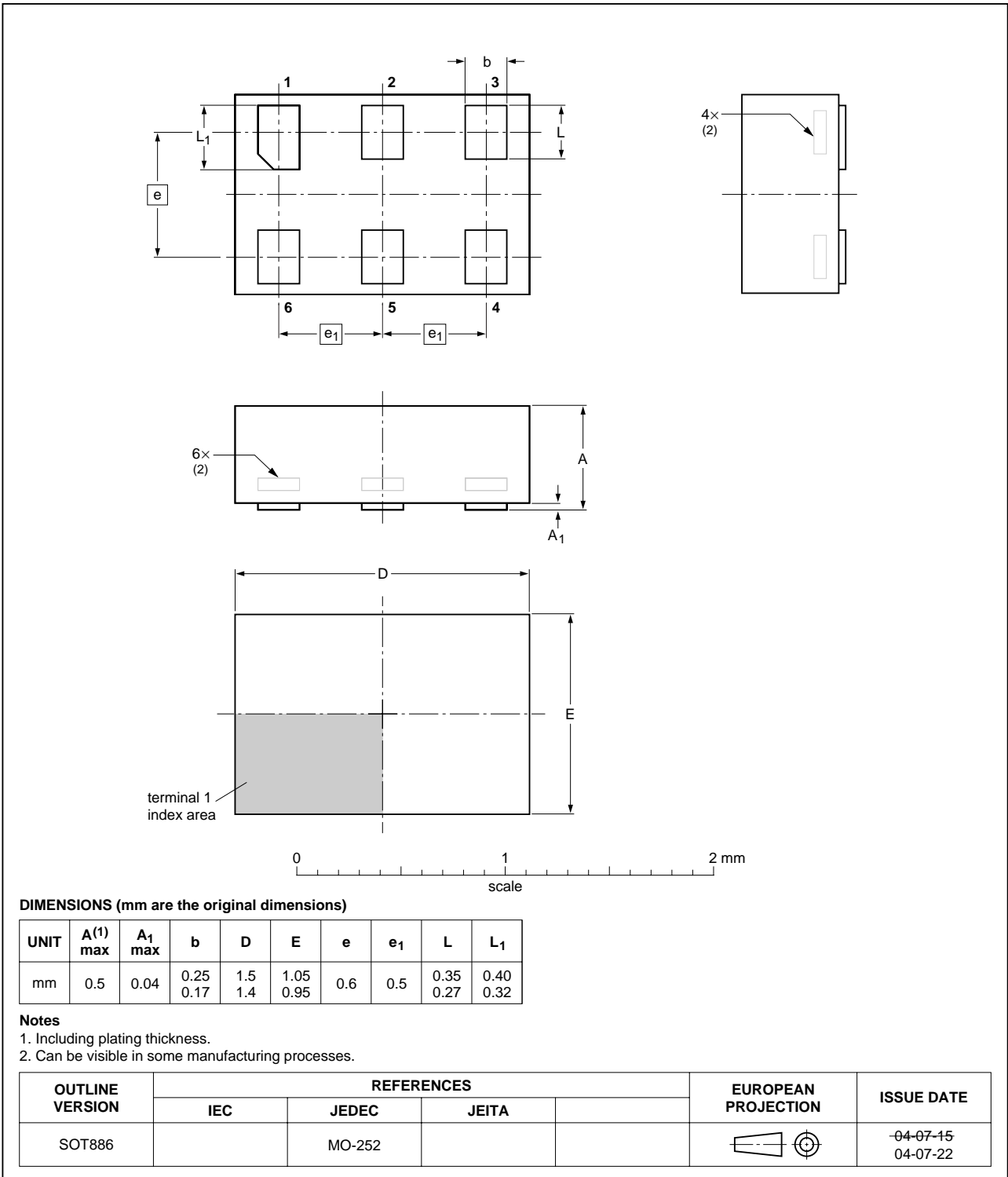

Fig 21. Package outline SOT886 (XSON6)

16. Revision history

Table 15: Revision history

Document ID	Release date	Data sheet status	Change notice	Doc. number	Supersedes
74LVC1G3157_1	20050207	Product data sheet	-	9397 750 14524	-

17. Data sheet status

Level	Data sheet status ^[1]	Product status ^[2] ^[3]	Definition
I	Objective data	Development	This data sheet contains data from the objective specification for product development. Philips Semiconductors reserves the right to change the specification in any manner without notice.
II	Preliminary data	Qualification	This data sheet contains data from the preliminary specification. Supplementary data will be published at a later date. Philips Semiconductors reserves the right to change the specification without notice, in order to improve the design and supply the best possible product.
III	Product data	Production	This data sheet contains data from the product specification. Philips Semiconductors reserves the right to make changes at any time in order to improve the design, manufacturing and supply. Relevant changes will be communicated via a Customer Product/Process Change Notification (CPCN).

[1] Please consult the most recently issued data sheet before initiating or completing a design.

[2] The product status of the device(s) described in this data sheet may have changed since this data sheet was published. The latest information is available on the Internet at URL <http://www.semiconductors.philips.com>.

[3] For data sheets describing multiple type numbers, the highest-level product status determines the data sheet status.

18. Definitions

Short-form specification — The data in a short-form specification is extracted from a full data sheet with the same type number and title. For detailed information see the relevant data sheet or data handbook.

Limiting values definition — Limiting values given are in accordance with the Absolute Maximum Rating System (IEC 60134). Stress above one or more of the limiting values may cause permanent damage to the device. These are stress ratings only and operation of the device at these or at any other conditions above those given in the Characteristics sections of the specification is not implied. Exposure to limiting values for extended periods may affect device reliability.

Application information — Applications that are described herein for any of these products are for illustrative purposes only. Philips Semiconductors make no representation or warranty that such applications will be suitable for the specified use without further testing or modification.

19. Disclaimers

Life support — These products are not designed for use in life support appliances, devices, or systems where malfunction of these products can reasonably be expected to result in personal injury. Philips Semiconductors customers using or selling these products for use in such applications do so at their own risk and agree to fully indemnify Philips Semiconductors for any damages resulting from such application.

Right to make changes — Philips Semiconductors reserves the right to make changes in the products - including circuits, standard cells, and/or software - described or contained herein in order to improve design and/or performance. When the product is in full production (status 'Production'), relevant changes will be communicated via a Customer Product/Process Change Notification (CPCN). Philips Semiconductors assumes no responsibility or liability for the use of any of these products, conveys no license or title under any patent, copyright, or mask work right to these products, and makes no representations or warranties that these products are free from patent, copyright, or mask work right infringement, unless otherwise specified.

20. Contact information

For additional information, please visit: <http://www.semiconductors.philips.com>

For sales office addresses, send an email to: sales.addresses@www.semiconductors.philips.com

21. Contents

1	General description	1
2	Features	1
3	Quick reference data	1
4	Ordering information	2
5	Marking	2
6	Functional diagram	2
7	Pinning information	3
7.1	Pinning	3
7.2	Pin description	3
8	Functional description	3
8.1	Function table	3
9	Limiting values	4
10	Recommended operating conditions	4
11	Static characteristics	4
12	Dynamic characteristics	10
13	Waveforms	11
14	Additional dynamic characteristics	14
15	Package outline	17
16	Revision history	20
17	Data sheet status	21
18	Definitions	21
19	Disclaimers	21
20	Contact information	21



© Koninklijke Philips Electronics N.V. 2005

All rights are reserved. Reproduction in whole or in part is prohibited without the prior written consent of the copyright owner. The information presented in this document does not form part of any quotation or contract, is believed to be accurate and reliable and may be changed without notice. No liability will be accepted by the publisher for any consequence of its use. Publication thereof does not convey nor imply any license under patent- or other industrial or intellectual property rights.

Date of release: 7 February 2005
Document number: 9397 750 14524

Published in The Netherlands



LittleDiode supplies new, hard to find or obsolete electronic components and semiconductors all over the world.

With over two million different components listed you are sure to find the part you need.

Feel free to visit us today at our online store:

LittleDiode.com

Looking forward to providing you with the best possible service.