

74LVT16646

3.3V ABT 16-Bit Transceiver/Register with TRI-STATE® Outputs

General Description

The LVT16646 contains sixteen non-inverting bidirectional registered bus transceivers providing multiplexed transmission of data directly from the input bus or from the internal storage registers. Each byte has separate control inputs which can be shorted together for full 16-bit operation. The DIR inputs determine the direction of data flow through the device. The CPAB and CPBA inputs load data into the registers on the LOW-to-HIGH transition.

These transceivers are designed for low-voltage (3.3V) V_{CC} applications, but with the capability to provide a TTL interface to a 5V environment. The LVT16646 is fabricated with an advanced BiCMOS technology to achieve high speed operation similar to 5V ABT while maintaining a low power dissipation.

Features

- Input and output interface capability to systems at 5V V_{CC}
- Bus-Hold data inputs eliminate the need for external pull-up resistors to hold unused inputs
- Live insertion/extraction permitted
- Power Up/Down high impedance provides glitch-free bus loading
- Outputs source/sink $-32\text{ mA}/+64\text{ mA}$
- Available in SSOP and TSSOP
- Functionally compatible with the 74 series 16646
- Latch-up performance exceeds 500 mA

Logic Symbol

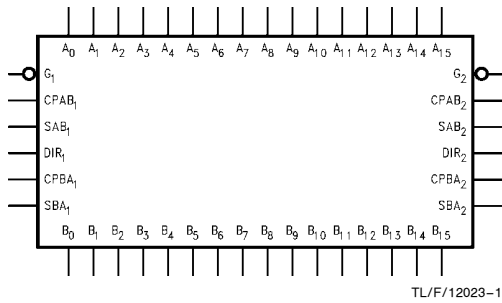

	SSOP	TSSOP JEDEC
Order Number	74LVT16646MEA 74LVT16646MEAX	74LVT16646MTD 74LVT16646MTDX
See NS Package Number	MS56A	MTD56

Connection Diagram

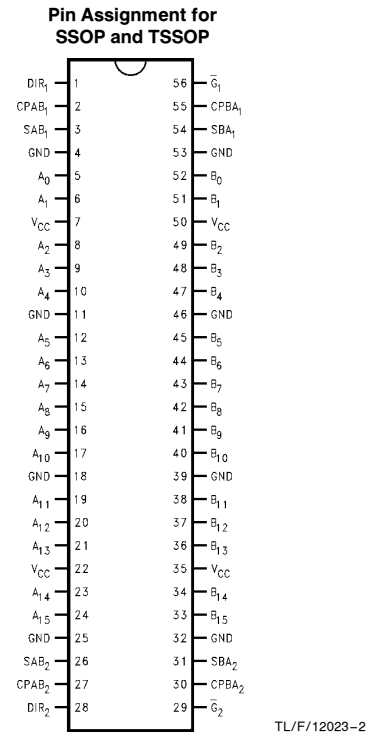

Preliminary Data: National Semiconductor reserves the right to make changes at any time without notice.

TRI-STATE® is a registered trademark of National Semiconductor Corporation.

74LVT16646 3.3V ABT 16-Bit Transceiver/Register with TRI-STATE Outputs

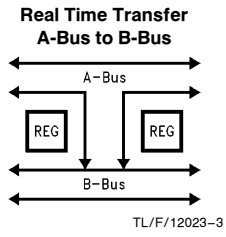

FIGURE 1

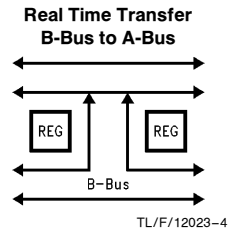

FIGURE 2

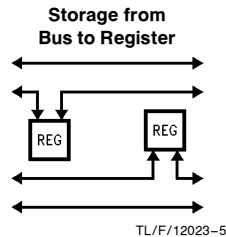

FIGURE 3

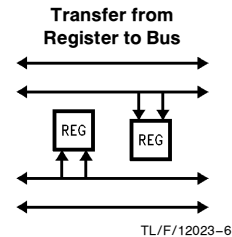

FIGURE 4

Truth Table (Note)

Inputs						Data I/O		Output Operation Mode
G ₁	DIR ₁	CPAB ₁	CPBA ₁	SAB ₁	SBA ₁	A ₀₋₇	B ₀₋₇	
H	X	H or L	H or L	X	X	Input	Input	Isolation
H	X	↗	X	X	X			Clock An Data into A Register
H	X	X	↗	X	X			Clock Bn Data Into B Register
L	H	X	X	L	X	Input	Output	An to Bn—Real Time (Transparent Mode)
L	H	↗	X	L	X			Clock An Data to A Register
L	H	H or L	X	H	X			A Register to Bn (Stored Mode)
L	H	↗	X	H	X			Clock An Data into A Register and Output to Bn
L	L	X	X	X	L	Output	Input	Bn to An—Real Time (Transparent Mode)
L	L	X	↗	X	L			Clock Bn Data into B Register
L	L	X	H or L	X	H			B Register to An (Stored Mode)
L	L	X	↗	X	H			Clock Bn into B Register and Output to An

Note: The data output functions may be enabled or disabled by various signals at the G and DIR inputs. Data input functions are always enabled; i.e., data at the bus pins will be stored on every LOW-to-HIGH transition of the appropriate clock inputs. Also applies to data I/O (A and B: 8-15) and #2 control pins.

H = HIGH Voltage Level X = Immaterial L = LOW Voltage Level ↗ = LOW-to-HIGH Transition.

Logic Diagrams

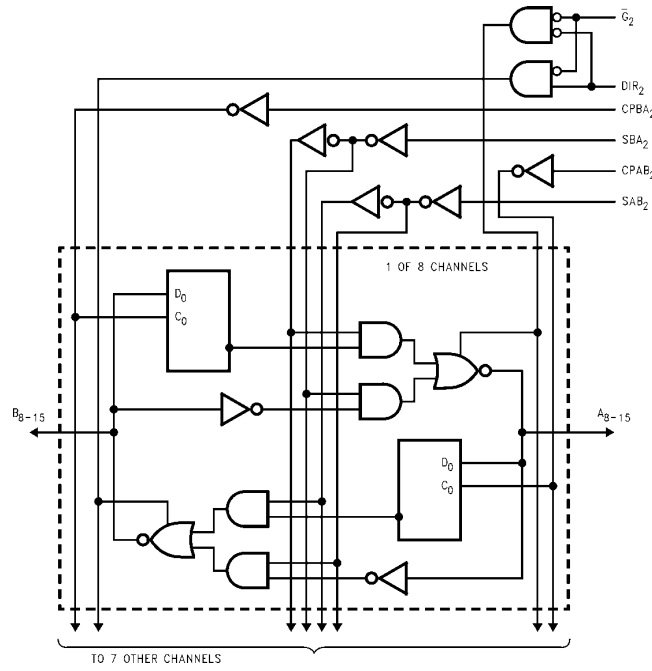

TL/F/12023-7

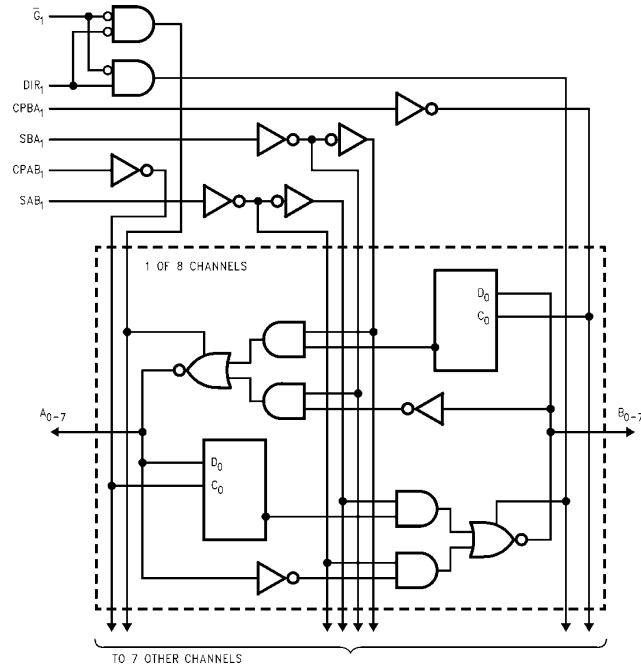

TL/F/12023-8

Please note that these diagrams are provided only for the understanding of logic operations and should not be used to estimate propagation delays.

74LVT16646 Ordering Information

The device number is used to form part of a simplified purchasing code where the package type and temperature range are defined as follows:

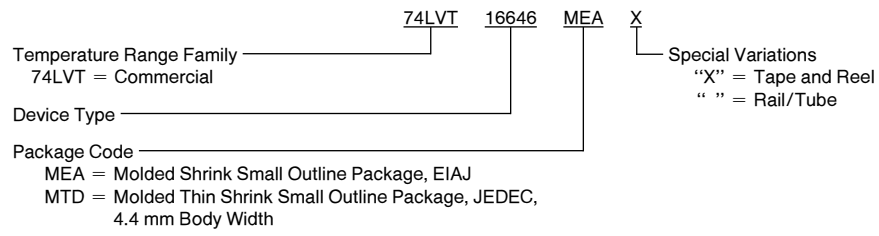

Physical Dimensions inches (millimeters) unless otherwise noted (Continued)

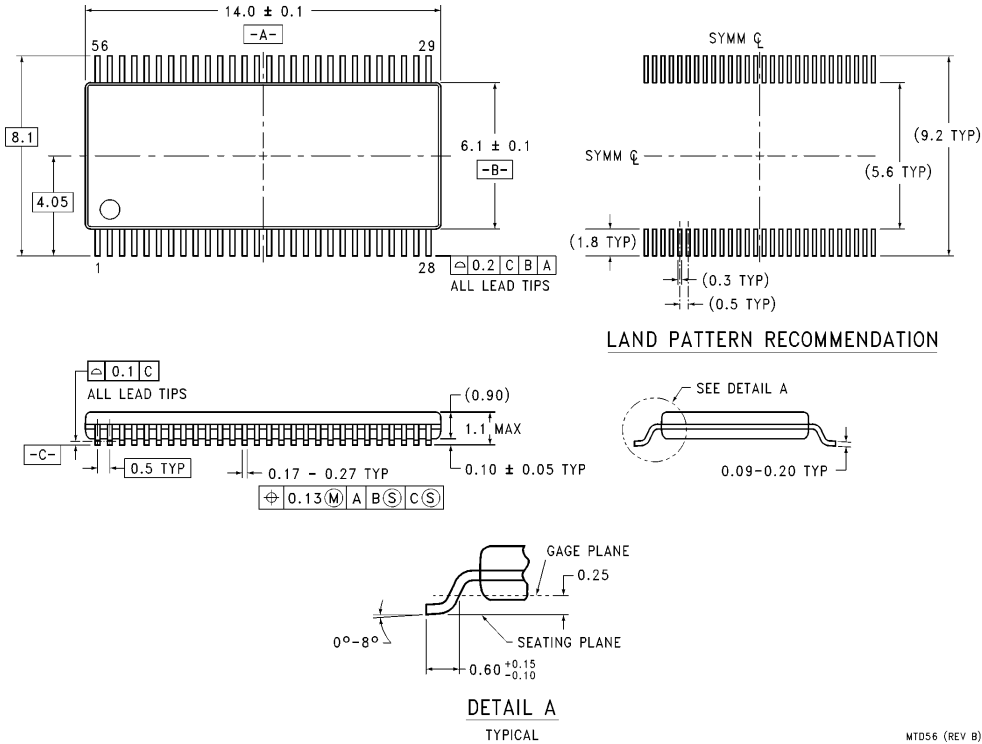

56-Lead Molded Thin Shrink Small Outline Package, JEDEC, 6.1 mm Body Width
Order Number 74LVT16646MTD or 74LVT16646MTDX
NS Package Number MTD56

LIFE SUPPORT POLICY

NATIONAL'S PRODUCTS ARE NOT AUTHORIZED FOR USE AS CRITICAL COMPONENTS IN LIFE SUPPORT DEVICES OR SYSTEMS WITHOUT THE EXPRESS WRITTEN APPROVAL OF THE PRESIDENT OF NATIONAL SEMICONDUCTOR CORPORATION. As used herein:

1. Life support devices or systems are devices or systems which, (a) are intended for surgical implant into the body, or (b) support or sustain life, and whose failure to perform, when properly used in accordance with instructions for use provided in the labeling, can be reasonably expected to result in a significant injury to the user.
2. A critical component is any component of a life support device or system whose failure to perform can be reasonably expected to cause the failure of the life support device or system, or to affect its safety or effectiveness.

<p>National Semiconductor Corporation Americas Tel: 1(800) 272-9959 Fax: 1(800) 737-7018 Email: support@nsc.com</p>	<p>National Semiconductor Europe Fax: +49 (0) 180-530 85 86 Email: europe.support@nsc.com Deutsch Tel: +49 (0) 180-530 85 85 English Tel: +49 (0) 180-532 78 32 Français Tel: +49 (0) 180-532 93 58 Italiano Tel: +49 (0) 180-534 16 80</p>	<p>National Semiconductor Southeast Asia Fax: (652) 2376 3901 Email: sea.support@nsc.com</p>	<p>National Semiconductor Japan Ltd. Tel: 81-3-5620-7561 Fax: 81-3-5620-6179</p>
<p>http://www.national.com</p>			

National does not assume any responsibility for use of any circuitry described, no circuit patent licenses are implied and National reserves the right at any time without notice to change said circuitry and specifications.

National Semiconductor was acquired by Texas Instruments.

http://www.ti.com/corp/docs/investor_relations/pr_09_23_2011_national_semiconductor.html

This file is the datasheet for the following electronic components:

74LVT16646 - <http://www.ti.com/product/74lvt16646?HQS=TI-null-null-dscatalog-df-pf-null-ww>



LittleDiode supplies new, hard to find or obsolete electronic components and semiconductors all over the world.

With over two million different components listed you are sure to find the part you need.

Feel free to visit us today at our online store:

LittleDiode.com

Looking forward to providing you with the best possible service.