

DATA SHEET

74LVT652

**3.3V Octal transceiver/register,
non-inverting (3-State)**

Product specification
Supersedes data of 1994 May 20
IC23 Data Handbook

1998 Feb 19

3.3V Octal transceiver/register, non-inverting (3-State)

74LVT652

FEATURES

- Independent registers for A and B buses
- Multiplexed real-time and stored data
- 3-State outputs
- Output capability: +64mA/-32mA
- TTL input and output switching levels
- Input and output interface capability to systems at 5V supply
- Bus-hold data inputs eliminate the need for external pull-up resistors to hold unused inputs
- Live insertion/extraction permitted
- No bus current loading when output is tied to 5V bus
- Power-up 3-State
- Power-up reset
- Latch-up protection exceeds 500mA per JEDEC Std 17
- ESD protection exceeds 2000V per MIL STD 883 Method 3015 and 200V per Machine Model

DESCRIPTION

The LVT652 is a high-performance BiCMOS product designed for V_{CC} operation at 3.3V.

This device combines low static and dynamic power dissipation with high speed and high output drive.

The 74LVT652 transceiver/register consists of bus transceiver circuits with 3-State outputs, D-type flip-flops, and control circuitry arranged for multiplexed transmission of data directly from the input bus or the internal registers. Data on the A or B bus will be clocked into the registers as the appropriate clock pin goes High. Output Enable (OEAB, \overline{OEBA}) and Select (SAB, SBA) pins are provided for bus management.

QUICK REFERENCE DATA

SYMBOL	PARAMETER	CONDITIONS $T_{amb} = 25^{\circ}C; GND = 0V$	TYPICAL	UNIT
t_{PLH} t_{PHL}	Propagation delay An to Bn or Bn to An	$C_L = 50pF;$ $V_{CC} = 3.3V$	2.8 2.6	ns
C_{IN}	Input capacitance	$V_I = 0V$ or 3V	4	pF
$C_{I/O}$	I/O capacitance	Outputs disabled; $V_{I/O} = 0V$ or 3V	10	pF
I_{CCZ}	Total supply current	Outputs disabled; $V_{CC} = 3.6V$	0.13	mA

ORDERING INFORMATION

PACKAGES	TEMPERATURE RANGE	OUTSIDE NORTH AMERICA	NORTH AMERICA	DWG NUMBER
24-Pin Plastic SOL	-40°C to +85°C	74LVT652 D	74LVT652 D	SOT137-1
24-Pin Plastic SSOP Type II	-40°C to +85°C	74LVT652 DB	74LVT652 DB	SOT340-1
24-Pin Plastic TSSOP Type I	-40°C to +85°C	74LVT652 PW	74LVT652PW DH	SOT355-1

PIN CONFIGURATION

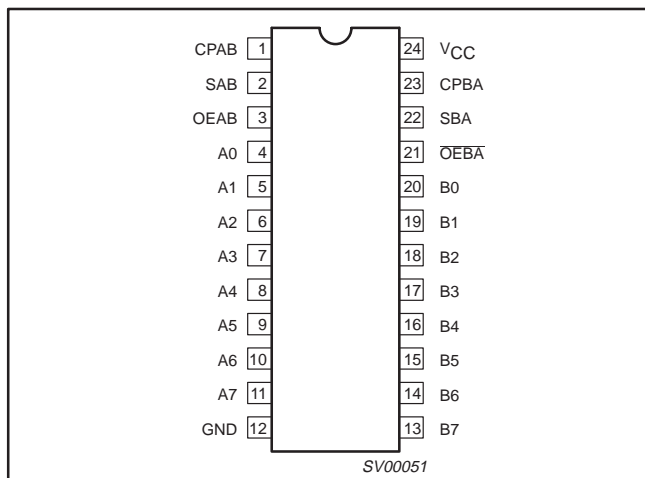

PIN DESCRIPTION

PIN NUMBER	SYMBOL	FUNCTION
1, 23	CPAB / CPBA	A to B clock input / B to A clock input
2, 22	SAB / SBA	A to B select input / B to A select input
3, 21	OEAB / OEBA	A to B Output Enable input (active-High) / B to A Output Enable input (active-Low)
4, 5, 6, 7, 8, 9, 10, 11	A0 – A7	Data inputs/outputs (A side)
20, 19, 18, 17, 16, 15, 14, 13	B0 – B7	Data inputs/outputs (B side)
12	GND	Ground (0V)
24	V_{CC}	Positive supply voltage

3.3V Octal transceiver/register, non-inverting (3-State)

74LVT652

LOGIC SYMBOL

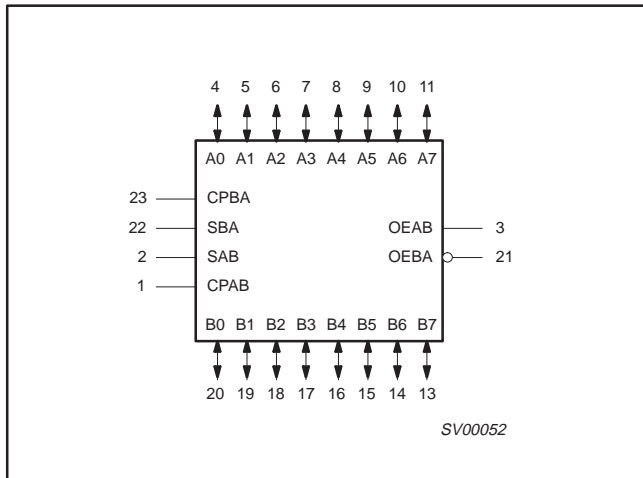

LOGIC SYMBOL (IEEE/IEC)

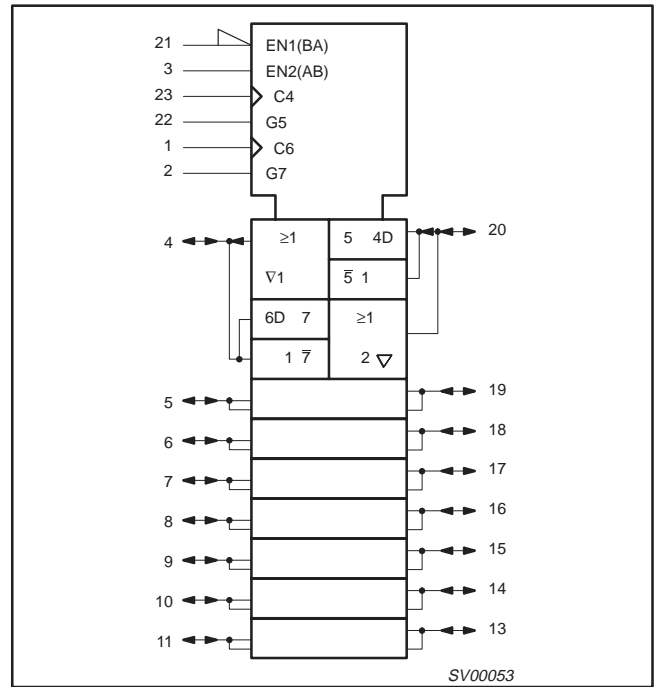

LOGIC DIAGRAM

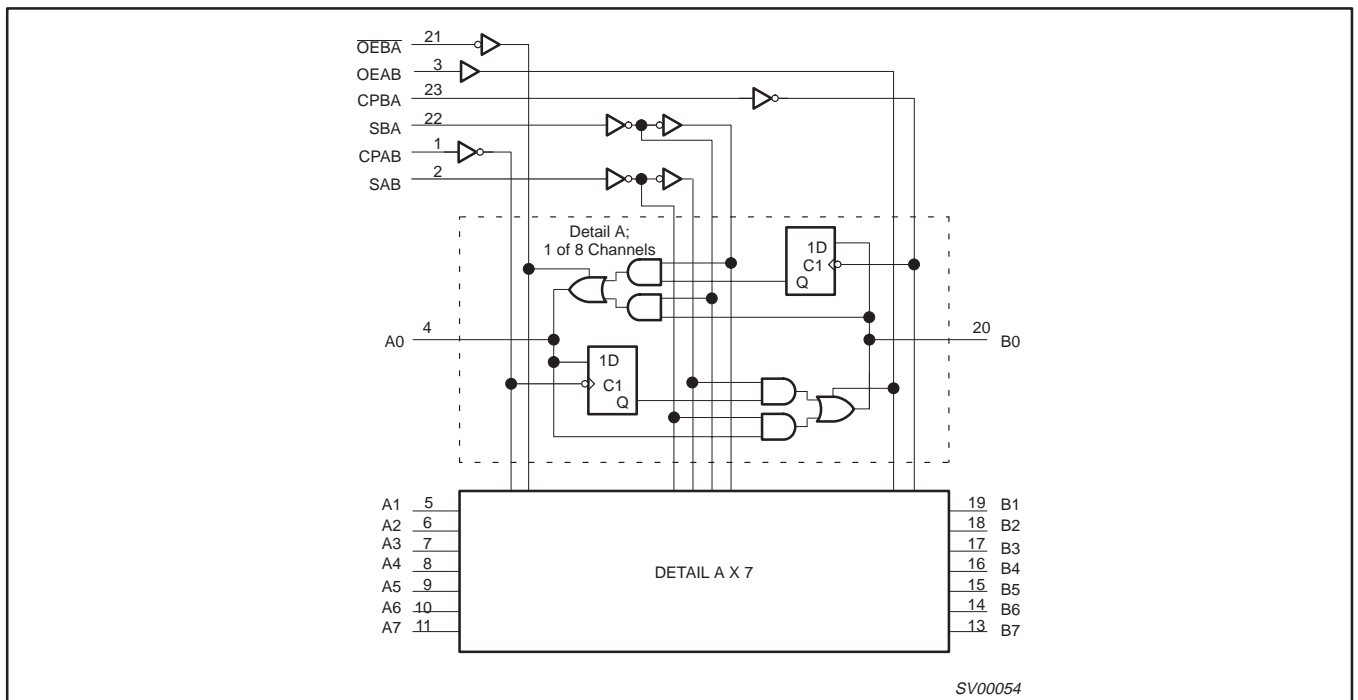

3.3V Octal transceiver/register, non-inverting (3-State)

74LVT652

The following examples demonstrate the four fundamental bus-management functions that can be performed with the 74LVT652.

The select pins determine whether data is stored or transferred through the device in real time.

The output enable pins determine the direction of the data flow.

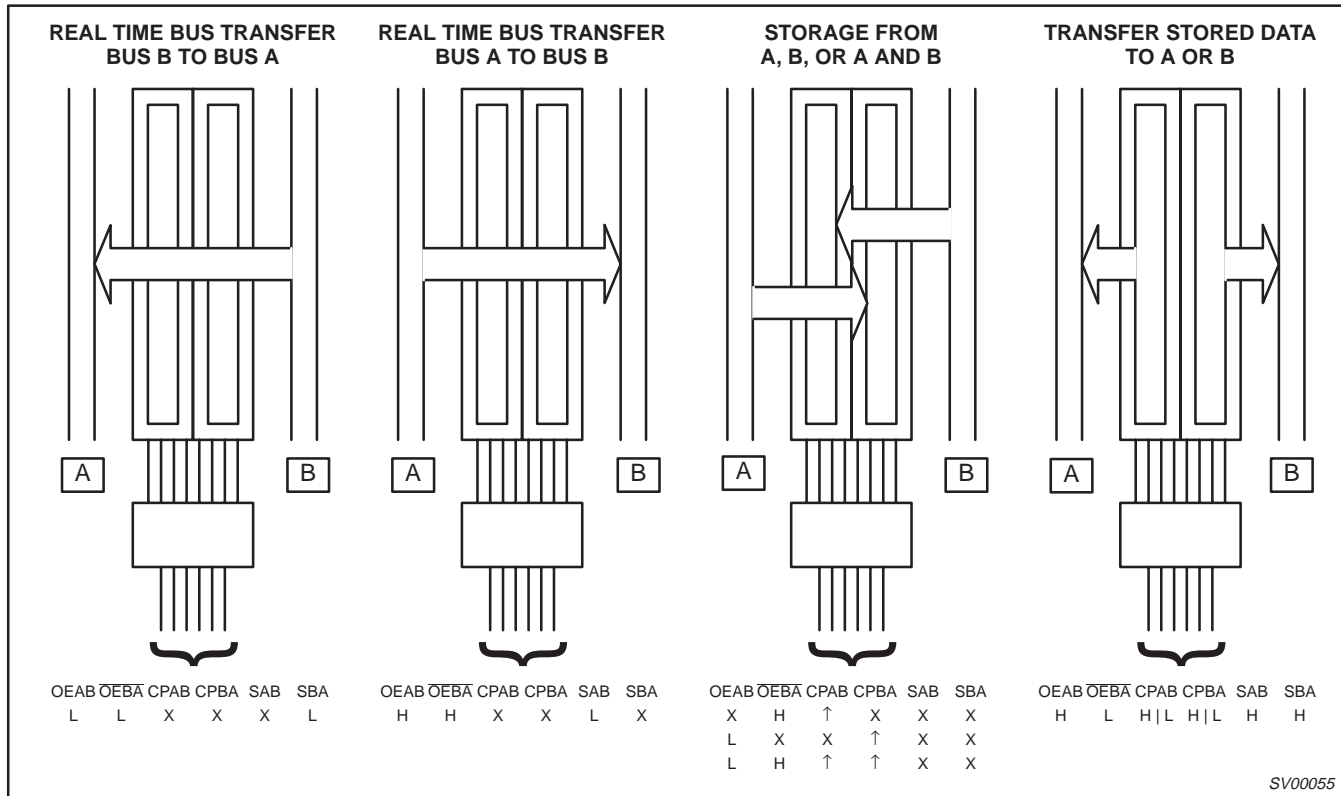

FUNCTION TABLE

INPUTS						DATA I/O		OPERATING MODE
OEAB	OEBA	CPAB	CPBA	SAB	SBA	An	Bn	
L	H	H or L	H or L	X	X	Input	Input	Isolation Store A and B data
L	H	↑	↑	X	X			
X	H	↑	H or L	X	X	Input	Unspecified** Output*	Store A, Hold B Store A in both registers
H	H	↑	↑	**	X			
L	X	H or L	↑	X	X	Unspecified** Output*	Input	Hold A, Store B Store B in both registers
L	L	↑	↑	**	X			
L	L	X	X	X	L	Output	Input	Real time B data to A bus Stored B data to A bus
L	L	X	H or L	X	H			
H	H	X	X	L	X	Input	Output	Real time A data to B bus Store A data to B bus
H	H	H or L	X	H	X			
H	L	H or L	H or L	H	H	Output	Output	Stored A data to B bus Stored B data to A bus

H = High voltage level

L = Low voltage level

X = Don't care

↑ = Low-to-High clock transition

* The data output function may be enabled or disabled by various signals at the OEBA and OEAB inputs. Data input functions are always enabled, i.e., data at the bus pins will be stored on every Low-to-High transition of the clock.

** If both Select controls (SAB and SBA) are Low, then clocks can occur simultaneously. If either Select control is High, the clocks must be staggered in order to load both registers.

3.3V Octal transceiver/register, non-inverting (3-State)

74LVT652

ABSOLUTE MAXIMUM RATINGS^{1,2}

SYMBOL	PARAMETER	CONDITIONS	RATING	UNIT
V_{CC}	DC supply voltage		-0.5 to +4.6	V
I_{IK}	DC input diode current	$V_I < 0$	-50	mA
V_I	DC input voltage ³		-0.5 to +7.0	V
I_{OK}	DC output diode current	$V_O < 0$	-50	mA
V_{OUT}	DC output voltage ³	Output in Off	-0.5 to +7.0	V
I_{OUT}	DC output current	Output in Low state	128	mA
		Output in High state	-64	
T_{stg}	Storage temperature range		-65 to +150	°C

NOTES:

- Stresses beyond those listed may cause permanent damage to the device. These are stress ratings only and functional operation of the device at these or any other conditions beyond those indicated under "recommended operating conditions" is not implied. Exposure to absolute-maximum-rated conditions for extended periods may affect device reliability.
- The performance capability of a high-performance integrated circuit in conjunction with its thermal environment can create junction temperatures which are detrimental to reliability. The maximum junction temperature of this integrated circuit should not exceed 150°C.
- The input and output negative voltage ratings may be exceeded if the input and output clamp current ratings are observed.

RECOMMENDED OPERATING CONDITIONS

SYMBOL	PARAMETER	LIMITS		UNIT
		MIN	MAX	
V_{CC}	DC supply voltage	2.7	3.6	V
V_I	Input voltage	0	5.5	V
V_{IH}	High-level input voltage	2.0		V
V_{IL}	Input voltage		0.8	V
I_{OH}	High-level output current		-32	mA
I_{OL}	Low-level output current		32	mA
	Low-level output current; current duty cycle $\leq 50\%$; $f \geq 1\text{kHz}$		64	
$\Delta t/\Delta v$	Input transition rise or fall rate; Outputs enabled		10	ns/V
T_{amb}	Operating free-air temperature range	-40	+85	°C

3.3V Octal transceiver/register, non-inverting (3-State)

74LVT652

DC ELECTRICAL CHARACTERISTICS

SYMBOL	PARAMETER	TEST CONDITIONS	LIMITS			UNIT
			Temp = -40°C to +85°C			
			MIN	TYP ¹	MAX	
V _{IK}	Input clamp voltage	V _{CC} = 2.7V; I _{IK} = -18mA		-0.9	-1.2	V
V _{OH}	High-level output voltage	V _{CC} = 2.7 to 3.6V; I _{OH} = -100μA	V _{CC} -0.2	V _{CC} -0.1		V
		V _{CC} = 2.7V; I _{OH} = -8mA	2.4	2.5		
		V _{CC} = 3.0V; I _{OH} = -32mA	2.0	2.2		
V _{OL}	Low-level output voltage	V _{CC} = 2.7V; I _{OL} = 100μA		0.1	0.2	V
		V _{CC} = 2.7V; I _{OL} = 24mA		0.3	0.5	
		V _{CC} = 3.0V; I _{OL} = 16mA		0.25	0.4	
		V _{CC} = 3.0V; I _{OL} = 32mA		0.3	0.5	
		V _{CC} = 3.0V; I _{OL} = 64mA		0.4	0.55	
V _{RST}	Power-up output low voltage ⁵	V _{CC} = 3.6V; I _O = 1mA; V _I = GND or V _{CC}		0.13	0.55	V
I _I	Input leakage current	V _{CC} = 3.6V; V _I = V _{CC} or GND	Control pins	±0.1	±1	μA
		V _{CC} = 0 or 3.6V; V _I = 5.5V		1.0	10	
		V _{CC} = 3.6V; V _I = 5.5V	I/O Data pins ⁴	1.0	20	
		V _{CC} = 3.6V; V _I = V _{CC}		0.1	1	
		V _{CC} = 3.6V; V _I = 0		-1	-5	
I _{OFF}	Output off current	V _{CC} = 0V; V _I or V _O = 0 to 4.5V		1	±100	μA
I _{HOLD}	Bus Hold current A inputs ⁶	V _{CC} = 3V; V _I = 0.8V	75	150		μA
		V _{CC} = 3V; V _I = 2.0V	-75	-150		
		V _{CC} = 0V to 3.6V; V _{CC} = 3.6V	±500			
I _{EX}	Current into an output in the High state when V _O > V _{CC}	V _O = 5.5V; V _{CC} = 3.0V		60	125	μA
I _{PU/PD}	Power up/down 3-State output current ³	V _{CC} ≤ 1.2V; V _O = 0.5V to V _{CC} ; V _I = GND or V _{CC} ; OE/OE = Don't care		15	±100	μA
I _{CCH}	Quiescent supply current	V _{CC} = 3.6V; Outputs High, V _I = GND or V _{CC} , I _O = 0		0.13	0.19	mA
I _{CCL}		V _{CC} = 3.6V; Outputs Low, V _I = GND or V _{CC} , I _O = 0		3	12	
I _{CCZ}		V _{CC} = 3.6V; Outputs Disabled; V _I = GND or V _{CC} , I _O = 0		0.13	0.19	
ΔI _{CC}	Additional supply current per input pin ²	V _{CC} = 3V to 3.6V; One input at V _{CC} -0.6V, Other inputs at V _{CC} or GND		0.1	0.2	mA

NOTES:

- All typical values are at V_{CC} = 3.3V and T_{amb} = 25°C.
- This is the increase in supply current for each input at the specified voltage level other than V_{CC} or GND
- This parameter is valid for any V_{CC} between 0V and 1.2V with a transition time of up to 10msec. From V_{CC} = 1.2V to V_{CC} = 3.3V ± 0.3V a transition time of 100μsec is permitted. This parameter is valid for T_{amb} = 25°C only.
- Unused pins at V_{CC} or GND.
- For valid test results, data must not be loaded into the flip-flops (or latches) after applying power.
- This is the bus hold overdrive current required to force the input to the opposite logic state.

3.3V Octal transceiver/register, non-inverting (3-State)

74LVT652

AC CHARACTERISTICS

GND = 0V, $t_R = t_F = 2.5\text{ns}$, $C_L = 50\text{pF}$, $R_L = 500\Omega$; $T_{\text{amb}} = -40^\circ\text{C}$ to $+85^\circ\text{C}$.

SYMBOL	PARAMETER	WAVEFORM	LIMITS				UNIT
			$V_{CC} = 3.3V \pm 0.3V$			$V_{CC} = 2.7V$	
			MIN	TYP ¹	MAX	MAX	
f_{MAX}	Maximum clock frequency	1	150	180			MHz
t_{PLH} t_{PHL}	Propagation delay CPAB to Bn or CPBA to An	1	1.8 2.0	3.7 3.7	6.0 5.7	6.9 6.4	ns
t_{PLH} t_{PHL}	Propagation delay An to Bn or Bn to An	2	1.2 1.0	2.8 2.6	4.7 4.6	5.5 5.3	ns
t_{PLH} t_{PHL}	Propagation delay SAB to Bn or SBA to An	3	1.4 1.4	3.7 4.0	6.4 6.2	7.6 6.8	ns
t_{PZH} t_{PZL}	Output enable time OEBA to An	5 6	1.0 1.0	2.9 3.0	5.8 6.0	7.2 7.3	ns
t_{PHZ} t_{PLZ}	Output disable time OEBA to An	5 6	2.2 1.8	3.9 3.2	6.5 5.8	6.9 5.9	ns
t_{PZH} t_{PZL}	Output enable time OEAB to Bn	5 6	1.0 1.2	3.3 3.4	6.5 6.3	7.5 7.1	ns
t_{PHZ} t_{PLZ}	Output disable time OEAB to Bn	5 6	1.7 1.5	4.5 3.8	7.2 5.8	8.1 6.3	ns

NOTE:

1. All typical values are at $V_{CC} = 3.3V$ and $T_{\text{amb}} = 25^\circ\text{C}$.

AC SETUP REQUIREMENTS

GND = 0V, $t_R = 2.5\text{ns}$, $t_F = 2.5\text{ns}$, $C_L = 50\text{pF}$, $R_L = 500\Omega$, $T_{\text{amb}} = 40^\circ\text{C}$ to 85°C

SYMBOL	PARAMETER	WAVEFORM	LIMITS					UNIT
			$T_{\text{amb}} = +25^\circ\text{C}$ $V_{CC} = +5.0V$			$T_{\text{amb}} = -40$ to $+85^\circ\text{C}$ $V_{CC} = +5.0V \pm 0.5V$		
			Min	Typ	Max	Min	Max	
$t_s(\text{H})$ $t_s(\text{L})$	Setup time ¹ An to CPAB, Bn to CPBA	4	1.5 2.2	0.9 1.1		1.6 2.5	ns	
$t_h(\text{H})$ $t_h(\text{L})$	Hold time ¹ An to CPAB, Bn to CPBA	4	0 0	-1.0 -1.0		0.0 0.0	ns	
$t_w(\text{H})$ $t_w(\text{L})$	Pulse width, High or Low CPAB or CPBA	1	3.3 3.3	1.0 2.0		3.3 3.3	ns	

NOTE:

1. This data sheet limit may vary among suppliers.

3.3V Octal transceiver/register, non-inverting (3-State)

74LVT652

AC WAVEFORMS

$V_M = 1.5V$, $V_{IN} = GND$ to $2.7V$

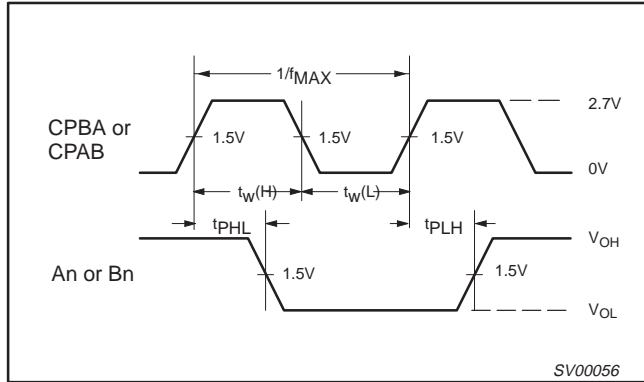

Waveform 1. Propagation Delay, Clock Input to Output, Clock Pulse Width, and Maximum Clock Frequency

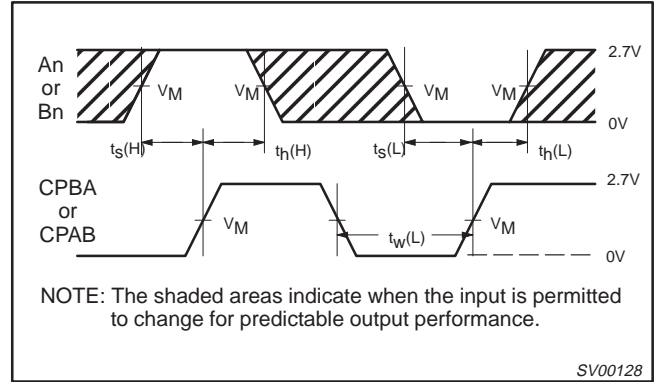

Waveform 4. Data Setup and Hold Times

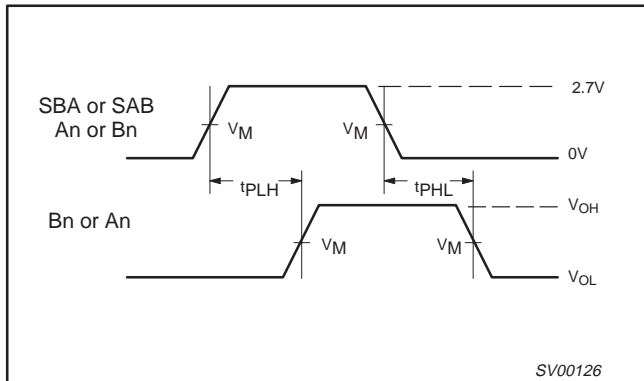

Waveform 2. Propagation Delay, An to Bn or Bn to An, SAB to Bn or SBA to An

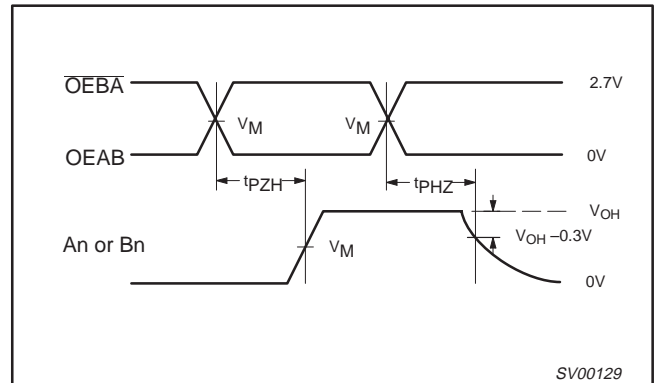

Waveform 5. 3-State Output Enable Time to High Level and Output Disable Time from High Level

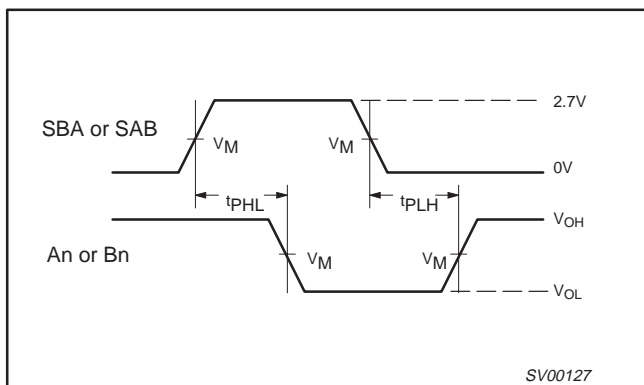

Waveform 3. Propagation Delay, SBA to An or SAB to Bn

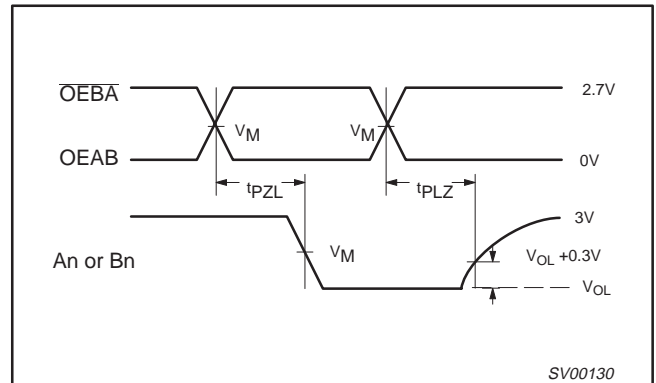

Waveform 6. 3-State Output Enable Time to Low Level and Output Disable Time from Low Level

3.3V Octal transceiver/register, non-inverting (3-State)

74LVT652

TEST CIRCUIT AND WAVEFORM

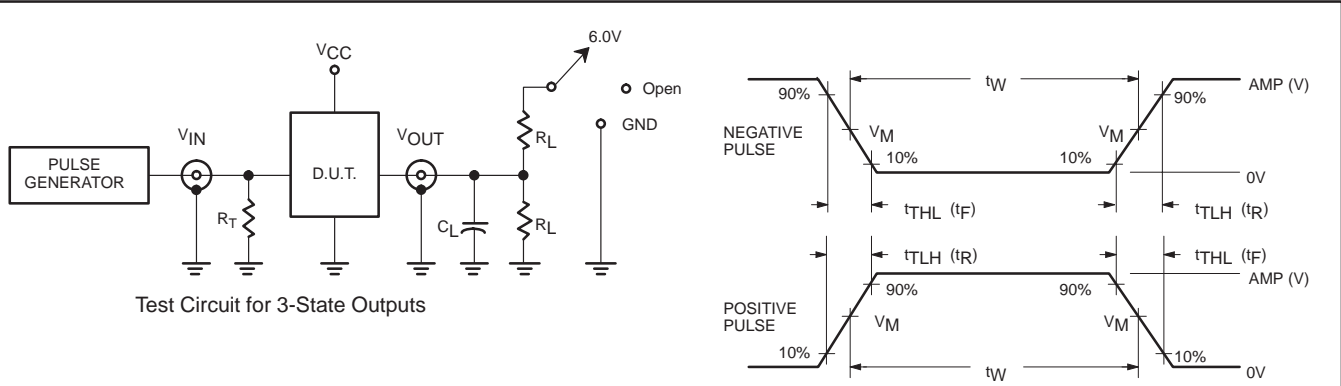

Test Circuit for 3-State Outputs

SWITCH POSITION

TEST	SWITCH
t_{PLH}/t_{PHL}	Open
t_{PLZ}/t_{PZL}	6V
t_{PHZ}/t_{PZH}	GND

DEFINITIONS

- R_L = Load resistor; see AC CHARACTERISTICS for value.
- C_L = Load capacitance includes jig and probe capacitance; see AC CHARACTERISTICS for value.
- R_T = Termination resistance should be equal to Z_{OUT} of pulse generators.

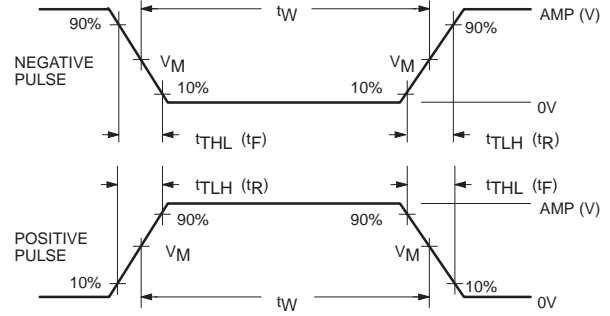

$V_M = 1.5V$
Input Pulse Definition

FAMILY	INPUT PULSE REQUIREMENTS				
	Amplitude	Rep. Rate	t_W	t_R	t_F
74LVT	2.7V	$\leq 10MHz$	500ns	$\leq 2.5ns$	$\leq 2.5ns$

SV00092

3.3V Octal transceiver/register, non-inverting (3-State)

74LVT652

SO24: plastic small outline package; 24 leads; body width 7.5 mm

SOT137-1

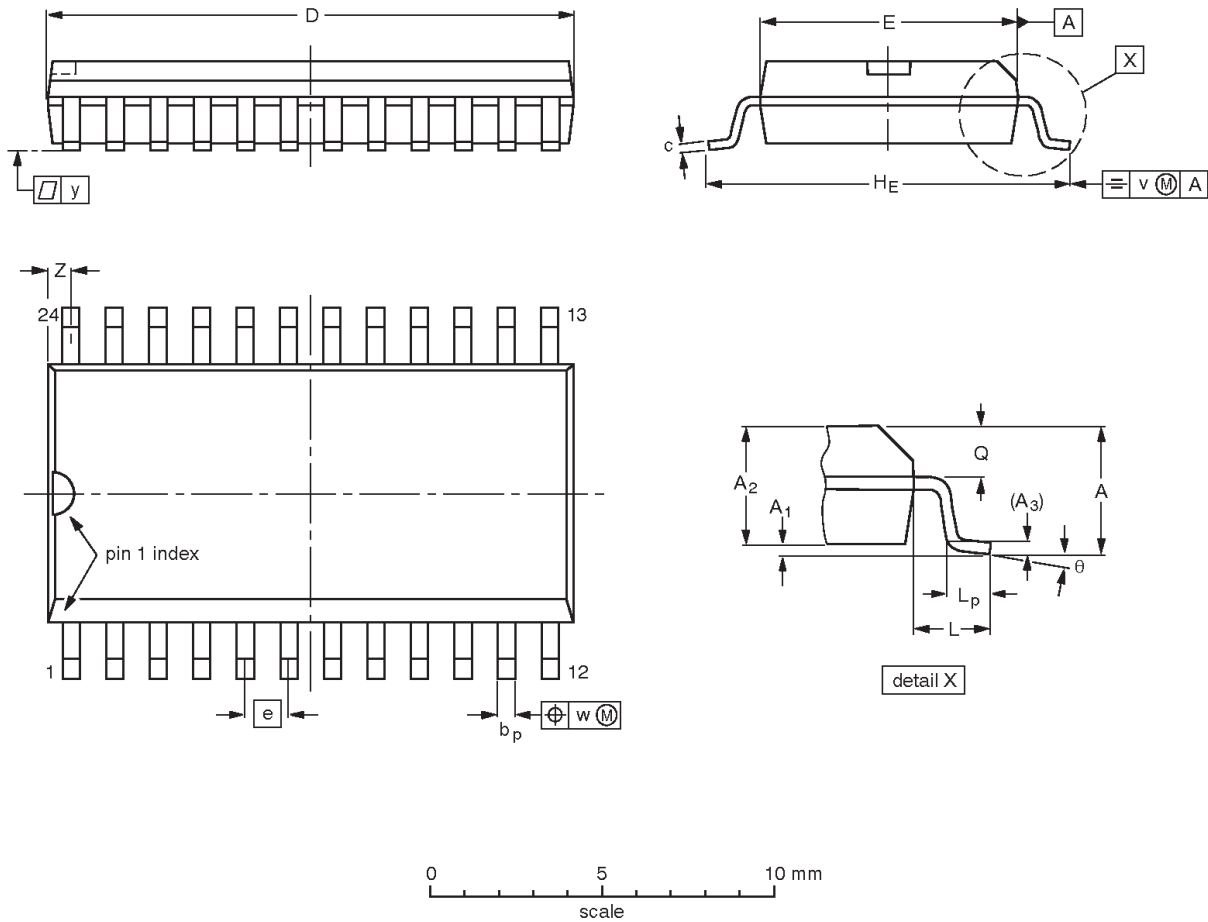

DIMENSIONS (inch dimensions are derived from the original mm dimensions)

UNIT	A max.	A ₁	A ₂	A ₃	b _p	c	D ⁽¹⁾	E ⁽¹⁾	e	H _E	L	L _p	Q	v	w	y	z ⁽¹⁾	θ
mm	2.65	0.30 0.10	2.45 2.25	0.25	0.49 0.36	0.32 0.23	15.6 15.2	7.6 7.4	1.27	10.65 10.00	1.4	1.1 0.4	1.1 1.0	0.25	0.25	0.1	0.9 0.4	8° 0°
inches	0.10	0.012 0.004	0.096 0.089	0.01	0.019 0.014	0.013 0.009	0.61 0.60	0.30 0.29	0.050	0.419 0.394	0.055	0.043 0.016	0.043 0.039	0.01	0.01	0.004	0.035 0.016	

Note

1. Plastic or metal protrusions of 0.15 mm maximum per side are not included.

OUTLINE VERSION	REFERENCES				EUROPEAN PROJECTION	ISSUE DATE
	IEC	JEDEC	EIAJ			
SOT137-1	075E05	MS-013AD				95-01-24 97-05-22

3.3V Octal transceiver/register, non-inverting (3-State)

74LVT652

SSOP24: plastic shrink small outline package; 24 leads; body width 5.3 mm

SOT340-1

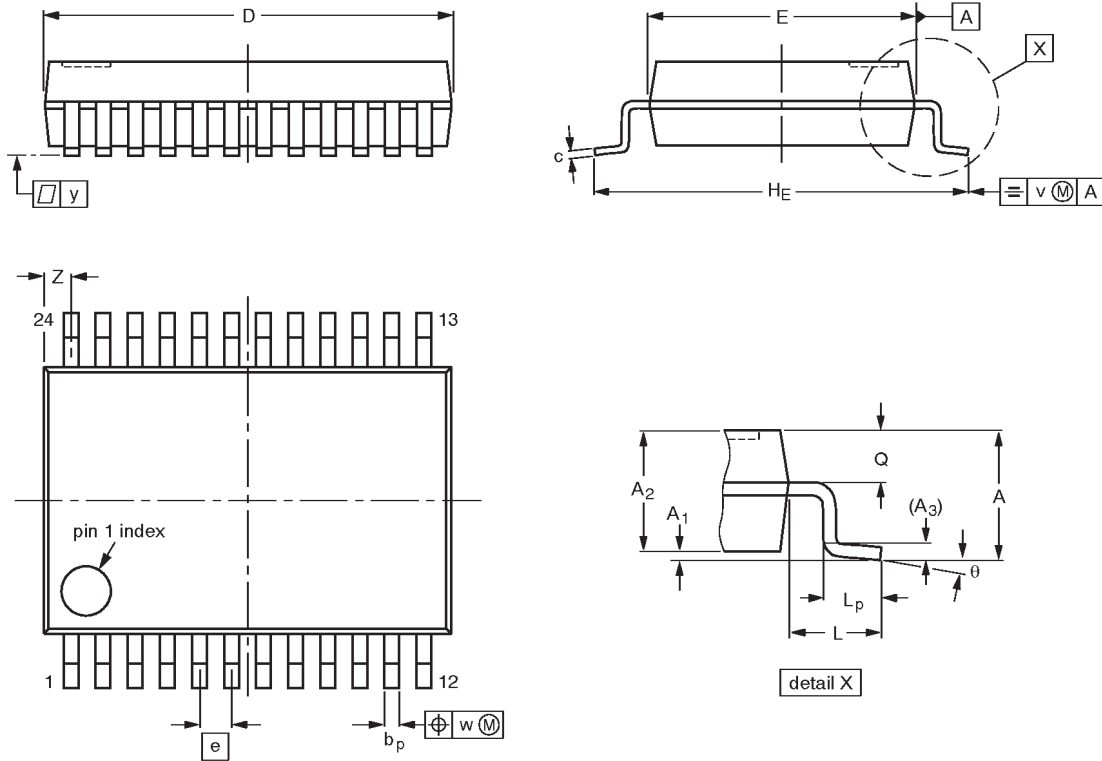

DIMENSIONS (mm are the original dimensions)

UNIT	A max.	A ₁	A ₂	A ₃	b _p	c	D ⁽¹⁾	E ⁽¹⁾	e	H _E	L	L _p	Q	v	w	y	Z ⁽¹⁾	θ
mm	2.0	0.21 0.05	1.80 1.65	0.25	0.38 0.25	0.20 0.09	8.4 8.0	5.4 5.2	0.65	7.9 7.6	1.25	1.03 0.63	0.9 0.7	0.2	0.13	0.1	0.8 0.4	8° 0°

Note

1. Plastic or metal protrusions of 0.20 mm maximum per side are not included.

OUTLINE VERSION	REFERENCES				EUROPEAN PROJECTION	ISSUE DATE
	IEC	JEDEC	EIAJ			
SOT340-1		MO-150AG				93-09-08 95-02-04

3.3V Octal transceiver/register, non-inverting (3-State)

74LVT652

TSSOP24: plastic thin shrink small outline package; 24 leads; body width 4.4 mm

SOT355-1

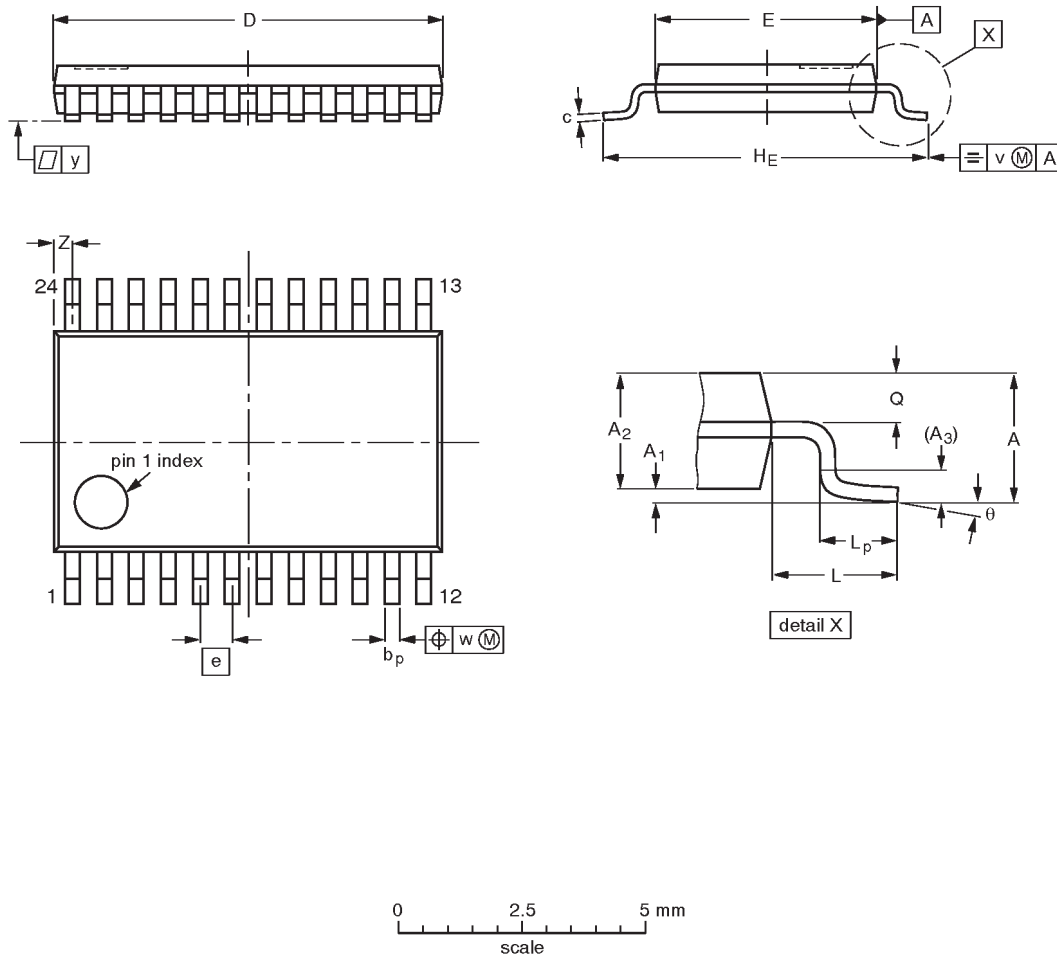

DIMENSIONS (mm are the original dimensions)

UNIT	A max.	A ₁	A ₂	A ₃	b _p	c	D ⁽¹⁾	E ⁽²⁾	e	H _E	L	L _p	Q	v	w	y	z ⁽¹⁾	θ
mm	1.10	0.15 0.05	0.95 0.80	0.25	0.30 0.19	0.2 0.1	7.9 7.7	4.5 4.3	0.65	6.6 6.2	1.0	0.75 0.50	0.4 0.3	0.2	0.13	0.1	0.5 0.2	8° 0°

Notes

1. Plastic or metal protrusions of 0.15 mm maximum per side are not included.
2. Plastic interlead protrusions of 0.25 mm maximum per side are not included.

OUTLINE VERSION	REFERENCES				EUROPEAN PROJECTION	ISSUE DATE
	IEC	JEDEC	EIAJ			
SOT355-1		MO-153AD				93-06-16 95-02-04

3.3V Octal transceiver/register, non-inverting
(3-State)

74LVT652

NOTES

3.3V Octal transceiver/register, non-inverting (3-State)

74LVT652

Data sheet status

Data sheet status	Product status	Definition [1]
Objective specification	Development	This data sheet contains the design target or goal specifications for product development. Specification may change in any manner without notice.
Preliminary specification	Qualification	This data sheet contains preliminary data, and supplementary data will be published at a later date. Philips Semiconductors reserves the right to make changes at any time without notice in order to improve design and supply the best possible product.
Product specification	Production	This data sheet contains final specifications. Philips Semiconductors reserves the right to make changes at any time without notice in order to improve design and supply the best possible product.

[1] Please consult the most recently issued datasheet before initiating or completing a design.

Definitions

Short-form specification — The data in a short-form specification is extracted from a full data sheet with the same type number and title. For detailed information see the relevant data sheet or data handbook.

Limiting values definition — Limiting values given are in accordance with the Absolute Maximum Rating System (IEC 134). Stress above one or more of the limiting values may cause permanent damage to the device. These are stress ratings only and operation of the device at these or at any other conditions above those given in the Characteristics sections of the specification is not implied. Exposure to limiting values for extended periods may affect device reliability.

Application information — Applications that are described herein for any of these products are for illustrative purposes only. Philips Semiconductors make no representation or warranty that such applications will be suitable for the specified use without further testing or modification.

Disclaimers

Life support — These products are not designed for use in life support appliances, devices or systems where malfunction of these products can reasonably be expected to result in personal injury. Philips Semiconductors customers using or selling these products for use in such applications do so at their own risk and agree to fully indemnify Philips Semiconductors for any damages resulting from such application.

Right to make changes — Philips Semiconductors reserves the right to make changes, without notice, in the products, including circuits, standard cells, and/or software, described or contained herein in order to improve design and/or performance. Philips Semiconductors assumes no responsibility or liability for the use of any of these products, conveys no license or title under any patent, copyright, or mask work right to these products, and makes no representations or warranties that these products are free from patent, copyright, or mask work right infringement, unless otherwise specified.

Philips Semiconductors
811 East Arques Avenue
P.O. Box 3409
Sunnyvale, California 94088-3409
Telephone 800-234-7381

© Copyright Philips Electronics North America Corporation 1998
All rights reserved. Printed in U.S.A.

print code

Date of release: 05-96

Document order number:

9397-750-03545

Let's make things better.



LittleDiode supplies new, hard to find or obsolete electronic components and semiconductors all over the world.

With over two million different components listed you are sure to find the part you need.

Feel free to visit us today at our online store:

LittleDiode.com

Looking forward to providing you with the best possible service.